

Semiconductors

Book S7

1987

Surface mounted semiconductors

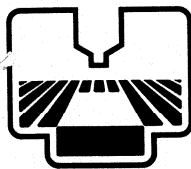

Elcoma – Philips Electronic Components and Materials Division – embraces a world-wide group of companies operating under the following names:

IBRAPE



Miniwatt

Signetics

Mullard

VALVO

PHILIPS

Elcoma offers you a technological partnership in developing your systems to the full. A partnership to which we can bring

- world-wide production and marketing
- know-how
- systems approach
- continuity
- broad product line
- fundamental research
- leading technologies
- applications support
- quality

SURFACE MOUNTED SEMICONDUCTORS

	<i>page</i>
Selection guide	
General purpose transistors	4
High-frequency transistors	6
Broad-band transistors	7
Switching transistors	7
Low-noise transistors	8
High-voltage transistors	9
Field-effect transistors	10
Trigger devices	11
Diodes	11
Variable capacitance diodes	12
Voltage regulator diodes	12
Rectifier diodes	12
Type number survey (alpha-numerical)	13
Conversion list (conventional type number to SMD type number)	21
Marking list	25
Tape and reel specification	29
Soldering recommendations	33
Thermal characteristics for SOT-23 and SOT-143 envelopes	39
General	
Type designation	45
Rating systems	47
Transistor ratings	49
Letter symbols	53
S-parameters	59
Device data in alpha-numerical sequence	61
Envelopes	787

SELECTION GUIDE

SELECTION GUIDE

GENERAL PURPOSE TRANSISTORS in SOT-23/SOT-89*/SOT-143**

type	RATINGS				h_{FE}		V_{CEsat}		f_T typ. MHz	page
	V_{CBO} V	V_{CEO} V	I_C mA	P_{tot} mW	min./max. at	I_C/V_{CE} mA/V	max. at	I_C/I_B mA		
P-N-P										
BC807	45	45	500	310	100/600	100/1	0,70	500/50	100	149
BC808	25	25	500	310						149
BC856	65	65	100	200	75/475	2/5	0,30	10/0,5	150	183
BC857	45	45	100	200	75/475	2/5	0,30	10/0,5	150	183
BC858	30	30	100	200	75/800	2/5	0,30	10/0,5	150	183
BC869*	20	20	1000	1000	85/375	500/1	0,50	1000/100	60	207
BCV26	40	30	300	350	> 20 000	100/5	1,0	100/0,1	220	241
BCV62**	30	30	100	200	100/800	2/5	0,65	100/5	150	249
BCV63**	30	30	100	300	100/900	2/5	0,65	100/5	200	253
BCV64**	30	30	100	300	100/900	2/5	0,30	100/0,5	200	257
BCV65**	30	30	100	300	75/800	2/5	0,30	10/0,5	100	261
BCW29	32	32	100	350	120/260	2/5	0,30	10/0,5	150	269
BCW30					215/500					269
BCW61A	32	32	200	150	120/220	2/5	0,25	10/0,25	180	289
BCW61B					180/310					289
BCW61C					250/460					289
BCW61D					380/630					289
BCW69	50	45	100	350	120/260	2/5	0,30	10/0,5	150	293
BCW70					120/500					293
BCW89	80	60			120/260					313
BCX17	50	45	500	425	100/600	100/1	0,62	500/50	100	317
BCX18	30	25								317
BCX51*	45	45	1000	1000	40/250	150/2	0,50	500/50	50	329
BCX52*	60	60			40/160					329
BCX53*	100	80			40/160					329
BCX71G	45	45	200	150	120/220	2/5	0,25	10/0,25	180	341
BCX71H	45	45	200	150	180/310					341
BCX71J	45	45	200	150	250/460					341
BCX71K	45	45	200	150	380/630					341
PMBTA55	60	60	500	300	50	10/1	0,25	100/10	50	769
PMBTA56	80	80	500	300	50	10/1	0,25	100/10	50	769
PMBTA63	30	30	500	300	5,000	10/5	1,5	100/0,1	125	771
PMBTA64	30	30	500	300	5,000	10/5	1,5	100/0,1	125	771

* Types in SOT-89 package.

** Types in SOT-143 package.

GENERAL PURPOSE TRANSISTORS in SOT-23/SOT-89*/SOT-143**

type	RATINGS				h _{FE} min./max. at I _C /V _{CE} mA/V	V _{CEsat} max. at I _C /I _B V mA	f _T typ. MHz	page		
	V _{CB0} V	V _{CEO} V	I _C mA	P _{tot} mW						
N-P-N										
BC817	45	45	500	310	100/600	100/1	0,70	500/50	200	155
BC818	25	25	500	310						155
BC846	65	65	100	200	220/800	2/5	0,25	10/0,5	300	161
BC847	45	45	100	200						161
BC848	30	30	100	200						161
BC868*	20	20	1000	1000	85/375	500/1	0,50	1000/100	60	201
BCV27	40	30	300	350	> 20 000	100/5	1,0	100/0,1	220	243
BCV61**	30	30	100	200	100/800	2/5	0,60	100/5	300	245
BCV71	80	60	100	350	110/220	2/5	0,25	10/0,5	300	265
BCV72					200/450					265
BCW31	32	32	100	350	110/220	2/5	0,25	10/0,5	300	277
BCW32					200/450					277
BCW33					420/800					277
BCW60A	32	32	200	150	120/220	2/5	0,35	10/0,25	250	285
BCW60B					180/310					285
BCW60C					250/460					285
BCW60D					380/630					285
BCW71	50	45	100	350	110/220	2/5	0,25	10/0,5	300	301
BCW72					220/450					301
BCW81					450/800					309
BCX19	50	45	500	425	100/600	100/1	0,62	500/50	200	323
BCX20	30	25								323
BCX54*	45	45	1000	1000	45/250	150/2	0,50	500/50	130	333
BCX55*	60	60			40/160					333
BCX56*	100	80			40/160					333
BCX70G	45	45	200	150	120/220	2/5	0,35	10/0,25	250	337
BCX70H					180/310					337
BCX70J					250/460					337
BCX70K					380/630					337

* Types in SOT-89 package.

** Types in SOT-143 package.

SELECTION GUIDE

GENERAL PURPOSE TRANSISTORS in SOT-23/SOT-89*/SOT-143**

type	RATINGS				h_{FE}		V_{CEsat}		f_T typ. MHz	page
	V_{CBO} V	V_{CEO} V	I_C mA	P_{tot} mW	min./max. at	I_C/V_{CE} mA/V	max. at	I_C/I_B mA		
N-P-N										
PMBT6428	60	50	200	350	250/600		0,2	10/0,5	300	757
PMBT6429	55	45	200	350	500/1250		0,2	10/0,5	300	757
PMBTA05	60	60	500	300	50	10/1	0,25	100/10	100	761
PMBTA06	80	80	500	300	50	10/1	0,25	100/10	100	761
PMBTA13	30	30	300	300	5,000	10/5	1,5	100/0,1	125	763
PMBTA14	30	30	300	300	10,000	10/5	1,5	100/0,1	125	763

HIGH-FREQUENCY TRANSISTORS in SOT-23

type	RATINGS				h_{FE}		F		f_T typ. MHz	C_{re} typ. pF	page
	V_{CBO} V	V_{CEO} V	I_C mA	P_{tot} mW	min./max. at	I_C/V_{CE} mA/V	typ. at f	MHz			
P-N-P											
BF536	30	30	25	200	25/—	1/10	5	200	350	—	351
BF550	40	40	25	200	50/—	1/10	2	0,1	325	0,5	355
BF569	40	35	30	200	25/—	3/10	4,5	800	900	0,33	359
BF579	20	20	25	150	20/—	10/10	4,5	800	1350	0,46	367
BF660	40	30	25	200	30/—	3/10	—	—	650	0,65	379
BF767	30	30	20	200	15/—	3/10	4	800	900	0,3	383
BF824	30	30	25	300	—	—	3	100	450	0,1	399
N-P-N											
BF570	40	15	100	300	> 40	10/1	—	—	> 490	1,6	363
BF840	40	40	25	300					380	0,3	405
BF841	40	40	25	300					380	0,3	405
BFS18	30	20	30	250	35/125	1/10	4	100	200	0,85	525
BFS19	30	20	30	250	65/225	1/10	4	100	260	0,85	525
BFS20	30	20	25	250	40/85	7/10	—	—	450	0,35	531

* Types in SOT-89 package.

** Types in SOT-143 package.

BROAD-BAND TRANSISTORS in SOT-23/SOT-89*/SOT-143**

type	RATINGS				h _{FE}		d _{im}		f _T	C _{re}	page
	V _{CB0} V	V _{CEO} V	I _C mA	P _{tot} mW	min./max. at	I _C /V _{CE} mA/V	typ. at f	MHz	typ. GHz	typ. pF	
P-N-P											
BFT92	20	15	25	200	20/—	14/10	60	493,25	5	0,7	553
BFT93	15	12	35	200	20/—	30/5	60	493,25	5	1,0	559
N-P-N											
BFG67**	20	10	50	300	20/—	15/5	3	2000	7,5	0,5	433
BFQ17*	40	25	150	1000	25/—	150/6	—	—	1,2	1,9	437
BFQ18A	25	15	150	1000	25/—	100/10	60	793,25	3,6	1,2	441
BFQ19*	20	15	75	500	25/—	75/10	—	—	5,0	1,3	445
BFQ67	20	10	50	180	100	15/5	3	2000	7,5	0,5	449
BFR53	18	10	50	250	25/—	50/5	60	217,0	2,0	0,9	463
BFR92	20	15	25	200	25/—	14/10	60	493,25	5,0	0,7	473
BFR92A	20	15	25	200	40/—	14/10	60	793,25	5,0	0,35	483
BFR93	15	12	35	200	25/—	30/5	60	493,25	5,0	0,8	495
BFR93A	15	12	35	250	40/—	30/5	60	793,25	5,0	0,6	505
BFS17	25	15	25	250	20/150	2/1	45	217	1,3	0,65	519
BFT25	8	5	2,5	50	20/—	1/1	—	—	2,3	0,45	537

SWITCHING TRANSISTORS in SOT-23/SOT-89*

type	RATINGS				h _{FE}		V _{CEsat}		t (max.)		page
	V _{CB0} V	V _{CEO} V	I _C mA	P _{tot} mW	min./max. at	I _C /V _{CE} mA/V	max. at I _C /I _B V	mA/mA	on/off at I _C /I _B ns	mA	
P-N-P											
BSR12	15	15	100	250	30/120	50/1	0,45	100/10	20/30	30/3	581
BSR15	60	40	600	425	100/300	150/10	1,6	500/50	45/100	150/15	593
BSR16	60	60	—	—	—	—	—	—	—	—	593
BSR18	40	40	200	250	50/150	10/1	0,40	50/5	70/250	10/1	603
BSR18A	40	40	200	250	100/300	10/1	0,4	50/5	70/300	10/1	603
BSR20	130	120	600	350	40/180	10/5	0,5	50/5	—	—	611
BSR20A	160	150	600	350	60/240	10/5	0,5	50/5	—	—	611
BSR30*	70	60	1000	1000	40/120	100/5	0,5	500/50	500/650	100/5	615
BSR31*	70	60	—	—	100/300	—	—	—	—	—	615
BSR32*	90	80	—	—	40/120	—	—	—	—	—	615
BSR33*	90	80	—	—	100/300	—	—	—	—	—	615
BSS63	110	100	100	350	30/—	25/1	0,25	25/2,5	—	—	627
BST60*	60	45	500	1000	1000/—	150/10	1,3	500/0,5	400/1500	500/0,5	653
BST61*	80	60	—	—	—	—	—	—	—	—	653
BST62*	100	80	—	—	—	—	—	—	—	—	653
PMBT3906	40	40	200	300	100/300	10/1	0,25	10/1	35/225	10/1	753
PXT3906	40	40	200	1000	100/300	10/1	0,25	10/1	35/225	10/1	783

* Types in SOT-89 package are denoted by an asterisk (*).

** Types in SOT-143 package are denoted by two asterisks (**).

SELECTION GUIDE

SWITCHING TRANSISTORS in SOT-23/SOT-89*

type	RATINGS				hFE		V _{CEsat}		t (max.)		page
	V _{CBO} V	V _{CEO} V	I _C mA	P _{tot} mW	min./max. at I _C /V _{CE} mA/V	max. at I _C /I _B mA/mA	max. at I _C /I _B V	mA/mA	on/off at I _C /I _B ns	mA	
N-P-N											
BSR13	60	30	800	425	100/300	150/10	1,6	500/50	35/285	150/—	587
BSR14	75	40					1,0				587
BSR17	60	40	200	350	50/150	10/1	0,3	50/5	70/225	10/1	599
BSR17A	60	40	200	350	100/300	10/1	0,3	50/5	70/250	10/1	599
BSR19	160	140	600	350	60/250	10/5	0,25	50/5			607
BSR19A	180	160	600	350	80/250	10/5	0,20	50/5			607
BSR40*	70	60	1000	1000	40/120	100/5	0,5	500/50	250/1000	100/5	619
BSR41*					100/300						619
BSR42*	90	80	1000	1000	40/120	100/5	0,5	500/50	250/1000	100/5	619
BSR43*					100/300						619
BSS64	120	80	100	350	20/80	10/1	0,2	50/15	/1000	15/1	633
BST50*	60	45	500	1000	1000/—	150/10	1,3	500/50	400/1500	500/0,5	649
BST51*	80	60	500	1000							649
BST52*	100	80	500	1000							649
BSV52	20	12	100	250	40/120	10/1	0,2	50/5	12/18	10/3	681
PMBT3903	60	40	200	300	50/150	10/1	0,3	50/5	35/175	10,1	749
PMBT3904	60	40	200	300	100/300	10/1	0,3	50/5	35/200	10,1	749
PXT3904*	60	40	200	1000	100/300						779

LOW-NOISE TRANSISTORS in SOT-23 (F < 4 dB at f = 1 kHz; B = 200 Hz)

type	RATINGS				hFE		V _{CEsat}		f _T typ. MHz	page
	V _{CBO} V	V _{CEO} V	I _C mA	P _{tot} mW	min./max. at I _C /V _{CE} mA/V	max. at I _C /I _B mA/mA	max. at I _C /I _B V	mA		
P-N-P										
BC859	30	30	100	200	125/800	2/5	0,3	10/0,5	150	191
BC860	45	45	100	200	125/800	2/5	0,3	10/0,5	150	191
BCF29	32	32	100	350	120/260	2/5	0,3	10/0,5	150	213
BCF30	32	32	100	350	215/500	2/5	0,3	10/0,5	150	213
BCF70	50	45	100	350	215/500	2/5	0,3	10/0,5	150	229
N-P-N										
BC849	30	30	100	200	450/800	2/5	0,25	10/0,5	300	171
BC850	45	45	100	200						171
BCF32	32	32	100	350	200/450	2/5	0,25	10/0,5	300	221
BCF33	32	32	100	350	420/800	2/5	0,25	10/0,5	300	221
BCF81	50	45	100	350	420/800	2/5	0,25	10/0,5	300	237

* Types in SOT-89 package are denoted by an asterisk (*).

HIGH-VOLTAGE TRANSISTORS in SOT-23/SOT-89*

type	RATINGS				hFE		V _{CEsat}		f _T min. MHz	page
	V _{CBO} V	V _{CEO} V	I _C mA	P _{tot} mW	min./max. at I _C /V _{CE}	max. at I _C /I _B	max. at I _C /I _B	max. at I _C /I _B		
P-N-P										
BF621*	300	—	20	1000	50/—	25/20	0,8	30/5	60	375
BF623*	250	250	20	1000	50/—	25/20	0,8	30/5	60	375
BF821	300	—	50	310	50/—	25/20	0,8	30/5	60	393
BF823	250	250	50	310	50/—	25/20	0,8	30/5	60	393
BST15*	200	200	1000	1000	30/150	50/10	2,5	50/5	15	641
BST16*	350	300	1000	1000	30/120	50/10	2,0	50/5	15	641
PMBTA92	300	300	500	300	40/—	10/10	0,5	20/2	50	773
PMBTA93	200	200	500	300	40/—	10/10	0,5	20/2	50	773
N-P-N										
BF620*	300	—	20	1000	50/—	25/20	0,6	30/5	60	371
BF622*	250	250	20	1000	50/—	25/20	0,6	30/5	60	371
BF820	300	—	50	310	50/—	25/20	0,6	30/5	60	387
BF822	250	250	50	310	50/—	25/20	0,6	30/5	60	387
BST39*	350	300	1000	1000	40/160	20/10	0,5	50/4	70	645
BST40*	350	250	1000	1000	40/160	20/10	0,5	50/4	70	645
PMBTA42	300	300	500	310	40/—	30/10	0,5	20/2	50	765
PMBTA43	200	200	500	310	40/—	30/10	0,5	20/2	50	765

* Types in SOT-89 package are denoted by an asterisk (*).

SELECTION GUIDE

FIELD-EFFECT TRANSISTOR in SOT-23/SOT-143*/SOT-89**

type	RATINGS				$-I_{GSS}$ max. nA	I_{DSS} min./max. mA	$-V_{(P)GS}$ max. V	$ y_{fs} $ min. mS	C_{re} max. pF	V_n max. μV	page
	$\pm V_{DS}$ V	$-V_{GSO}$ V	I_D mA	P_{tot} mW							
BF510	80	--	30	300	10	0,7/3,0	0,8	2,5	0,4	--	345
BF511						2,5/7,0	1,5	4			345
BF512						6/12	2,2	6			345
BF513						10/18	3	7			345
BF989*	20	--	20	200	50	2/20	2,7	9,5	0,025	--	407
BF990*	18	--	30	200	25	--	1,3	17	0,025	--	409
BF991*	20	--	20	200	50	4/25	2,5	10	0,020	--	413
BF992*	20	--	40	200	25	--	1,3	20	0,04	--	415
BF994*	20	--	30	200	50	2/20	2,5	15	0,025	--	417
BF994S*	20	--	50	300	50	4/20	2,5	15	0,025	--	421
BF996*	20	--	30	200	50	2/20	2,5	15	0,025	--	423
BF996S*	20	--	30	300	50	4/20	2,5	15	0,025	--	427
BF997*	20	--	30	300	10	2/20	2,5	15	0,025	--	429
BFR30	25	25	10	250	0,2	4/10	5	1	1,5	0,5	453
BFR31						1/5	2,5	1,5			453
BFR101A*	30	30	10	200	5	0,2/1,5	1,0	1,2	--	--	517
BFR101B*	30	30	10	200	5	1/5	2,5	2,5	--	--	517
BFT46	25	25	10	250	0,2	0,2/1,5	1,0	1,0	1,5	0,5	545
BSD20*	10	--	50	230	1,0	--	2,0	--	0,6	--	577
BSD22*	20	--	50	230	1,0	--	2,0	--	0,6	--	577
BSR56	40	40	--	250	1	50/--	10	--	5	--	623
BSR57						20/100	6				623
BSR58						8/80	4				623
BSS83*	10	--	50	230	10	--	2,0	--	0,6	--	637
BST80**	80	20	500	1000	100	-/0,01	--	300	8	--	657
BST82	80	20	175	300	100	-/0,001	3,5	150	3	--	661
BST84**	200	20	250	1000	100	-/0,01	--	250	5	--	665
BST86**	180	20	300	1000	100	-/0,01	--	250	6	--	669
BST120**	60	20	300	1000	100	-/0,01	--	200	8	--	673
BST122**	50	20	250	1000	100	-/0,01	--	125	8	--	677
PMBF4391	40	40	--	250	1	50/150	10	--	3,5	--	735
PMBF4392	40	40	--	250	1	25/75	5	--	3,5	--	735
PMBF4393	40	40	--	250	1	5/30	3	--	3,5	--	735

* Types in SOT-143 package are denoted by an asterisk (*).

** Types in SOT-89 package are denoted by two asterisks (**).

TRIGGER DEVICES

P-N-P-N	case	V _{GA} max. V	I _A max. mA	I _P μA	I _V μA	page
BRY61	SOT-23	70	175	5/1	30/50	565
BRY62	SOT-143	70	175	—	—	571

DIODES in SOT-23 unless indicated

type	description	RATINGS		t _{rr} max. ns	V _F max. (mV) at I _F = mA		C _d max.	page
		V _R V	I _F mA		10/100	— 150		
BA682**	band switch	35	100	—	—/1000	—	1,5	63
BA683**	band switch	35	100	—	—/1000	—	1,5	63
BAS16	high-speed switch	75	250	6	855/—	1250	2	65
BAS17	low-voltage stabilizer	—	250	—	830/960	—	140	69
BAS19	high-speed switch	100	200	50	—/1000	—	5	73
BAS20	high-speed switch	150	200	50	—/1000	—	5	73
BAS21	high-speed switch	200	200	50	—/1000	—	5	73
BAS28*	fast switch double diode	75	250	6	855/—	1250	2	81
BAS29	switch	90	250	50	750/900	—	35	85
BAS31	two diodes in series	90	250	50	750/900	—	35	85
BAS32**	high-speed switch	75	200	4	—/1000	—	2	87
BAS35	common anode double diode	90	250	50	750/900	—	35	85
BAS56*	ultra-high-speed switch double diode	60	200	6	750/—	—	2,5	95
BAT17	Schottky barrier	4	30	—	600/—	—	1	99
BAT18	band switch	35	100	—	/1200	—	1	103
BAT54	Schottky barrier	30	200	5	400/1000	—	10	107
BAT74*	Schottky barrier; double diode	30	200	5	400/1000	—	10	111
BAV23**	two diodes	200	200	50	—/1000	—	2,5	115
BAV70	common cathode double diode	70	250	6	855/—	1250	1,5	117
BAV99	two diodes in series	70	250	6	855/—	1250	1,5	121
BAV100**	general purpose	50	250	50	—/1000	—	5	125
BAV101**	general purpose	100	250	50	—/1000	—	5	125
BAV102**	general purpose	150	250	50	—/1000	—	5	125
BAV103**	general purpose	200	250	50	—/1000	—	5	125
BAW56	common anode double diode	70	250	6	855/—	1250	2	133

* SOT-143.

** SOD-80.

VARIABLE CAPACITANCE DIODES SOT-23 and SOD-80

type	RATINGS		CHARACTERISTICS				page
	V_R	I_F	C_d at V_R		C_d ratio at $V_R = 3/25$ V at $f = 1$ MHz	r_D	
	V	mA	pF	V		Ω	
BB215	30	20	1,8 – 2,2	28	typ. 8,3	typ. 0,63	137
BB219	32	20	2,6 – 3,2	28	12 to 15	typ. 0,7	139
BBY31	28	20	1,8 – 2,8	25	typ. 5	< 1,2	141
BBY40	28	20	4,3 – 6	25	5 to 5,6	< 0,6	145

VOLTAGE REGULATOR DIODES

type	case	range (V)	voltage tolerance %	P_{tot} mW	I_{ZRM} mA	I_{FRM} mA	max. V_F at I_F		page
							V	mA	
BZD27	SOD-87	3,9 to 270	5	2300	—	—	—	—	697
BZV49	SOT-89	2,4 to 75	5	1000	—**	250	1	50	701
BZV55	SOD-80	2,4 to 75	5	500	—	250	0,9	10	711
BZX84	SOT-23	2,4 to 75	5*	350	250	250	0,9	10	725

RECTIFIER DIODES

type	case	$I_F(AV)$ A	V_{RRM} V	V_R V	I_{FRM} A	I_{FSM} A	t_{rr} ns	V_F at I_F V	I_F A	page
BYD17D	SOD-87	1,5	200	200	5,5	20	—	1,05	1	693
BYD17G	SOD-87	1,5	400	400	5,5	20	—	1,05	1	693
BYD17J	SOD-87	1,5	600	600	5,5	20	—	1,05	1	693
BYD17K	SOD-87	1,5	800	800	5,5	20	—	1,05	1	693
BYD17M	SOD-87	1,5	1000	1000	5,5	20	—	1,05	1	693
BYD37D	SOD-87	1,5	200	200	12	20	250	1,3	1	697
BYD37G	SOD-87	1,5	400	400	12	20	250	1,3	1	697
BYD37J	SOD-87	1,5	600	600	12	20	250	1,3	1	697
BYD37K	SOD-87	1,5	800	800	12	20	300	1,3	1	697
BYD37M	SOD-87	1,5	1000	1000	12	20	300	1,3	1	697

* Types with 2% tolerance available on request.

** I_{ZRM} limited by P_{ZRMmax} .

In this alpha-numeric list we present all surface mounted devices mentioned in this handbook.

type number	SOT-23	SOT-89	SOT-143	SOD-80	marking type reverse type	device type	nearest conventional type(s)	complement	page
BA682	-	-	-	●	red band	diode	BA482		63
BA683	-	-	-	●	red and orange	diode	BA483		63
BAS16	●	-	-	-	A6	diode	BAW62, 1N4148		65
BAS17	●	-	-	-	A91	diode	BA314		69
BAS19	●	-	-	-	A8	diode	BAV19		73
BAS20	●	-	-	-	A81	diode	BAV20		73
BAS21	●	-	-	-	A82	diode	BAV21		73
BAS28	-	-	●	-	A61	2 diodes	1N4148		81
BAS29	●	-	-	-	L20	diode	BAX12		85
BAS31	●	-	-	-	L21	2 diodes	BAX12		85
BAS32	-	-	-	●	black band	diode	1N4148		87
BAS35	●	-	-	-	L22	2 diodes	BAX12		85
BAS56	-	-	●	-	L51	2 diodes	BAV10		95
BAT17	●	-	-	-	A3	diode	BA480		99
BAT18	●	-	-	-	A2	diode	BA482		103
BAT54	●	-	-	-	L4	diode	BAT85		107
BAT74	-	-	●	-	L41	2 diodes	BAT85		111
BAV23	-	-	●	-	L30	2 diodes	BAV21		115
BAV70	●	-	-	-	A4	2 diodes	BAW62, 1N4148 (double)		117
BAV99	●	-	-	-	A7	2 diodes	BAW62, 1N4148 (double)		121
BAV100	-	-	-	●	green and black	diode	BAV10		125
BAV101	-	-	-	●	green and brown	diode	BAV19		125
BAV102	-	-	-	●	green and red	diode	BAV20		125
BAV103	-	-	-	●	green and orange	diode	BAV21		125
BAW56	●	-	-	-	A1	diode	BAW62, 1N4148 (double)		133
BB215	-	-	-	●	white and green	diode	BB405B		137
BB219	-	-	-	●	white	diode	BB909		139
BBY31	●	-	-	-	S1	diode	BB405		141
BBY40	●	-	-	-	S2	diode	BB809		145
BC807-16	●	-	-	-	5A 5AR	PNP	BC327-16	BC817-16	149
-25	●	-	-	-	5B 5BR	PNP	-25	-25	149
-40	●	-	-	-	5C 5CR	PNP	-40	-40	149
BC808-16	●	-	-	-	5E 5ER	PNP	BC328-16	BC818-16	149
-25	●	-	-	-	5F 5FR	PNP	-25	-25	149

TYPE NUMBER SURVEY

type number	SOT-23	SOT-89	SOT-143	SOD-80	marking type		device type	nearest conventional type(s)	complement	page
						reverse type				
BC808-40	●	-	-	-	5G	5GR	PNP	BC328-40	BC818-40	149
BC817-16	●	-	-	-	6A	6AR	NPN	BC337-16	BC807-16	155
-25	●	-	-	-	6B	6BR	NPN	-25	-25	155
-40	●	-	-	-	6C	6CR	NPN	-40	-40	155
BC818-16	●	-	-	-	6E	6ER	NPN	BC328-16	BC808-16	155
BC818-25	●	-	-	-	6F	6FR	NPN	BC328-25	BC808-25	155
-40	●	-	-	-	6G	6GR	NPN	-40	-40	155
BC846A	●	-	-	-	1A	1AR	NPN	BC546A	BC856A	161
BC846B	●	-	-	-	1B	1BR	NPN	BC546B	BC856B	161
BC847A	●	-	-	-	1E	1ER	NPN	BC547A, BC107A	BC857A	161
BC847B	●	-	-	-	1F	1FR	NPN	BC547B, BC107B	BC857B	161
BC847C	●	-	-	-	1G	1GR	NPN	BC547C	BC857C	161
BC848A	●	-	-	-	1J	1JR	NPN	BC548A, BC108A	BC858A	161
BC848B	●	-	-	-	1K	1KR	NPN	BC548B, BC108B	BC858B	161
BC848C	●	-	-	-	1L	1LR	NPN	BC548C, BC108C	BC858C	161
BC849B	●	-	-	-	2B	2BR	NPN	BC549B, BC109B	BC859B	171
BC849C	●	-	-	-	2C	2CR	NPN	BC549C, BC109C	BC859C	171
BC850B	●	-	-	-	2F	2FR	NPN	BC550B, BCY59	BC860B	171
BC850C	●	-	-	-	2G	2GR	NPN	BC550C, BCY59	BC860C	171
BC856A	●	-	-	-	3A	3AR	PNP	BC556A	BC846A	183
BC856B	●	-	-	-	3B	3BR	PNP	BC556B	BC846B	183
BC857A	●	-	-	-	3E	3ER	PNP	BC557A, BC177A	BC847A	183
BC857B	●	-	-	-	3F	3FR	PNP	BC557B, BC177B	BC847B	183
BC857C	●	-	-	-	3G	3GR	PNP	BC557C	BC847C	183
BC858A	●	-	-	-	3J	3JR	PNP	BC558A, BC178A	BC848A	183
BC858B	●	-	-	-	3K	3KR	PNP	BC558B, BC178B	BC848B	183
BC858C	●	-	-	-	3L	3LR	PNP	BC558C	BC848C	183
BC859A	●	-	-	-	4A	4AR	PNP	BC559A, BC179A, BCY78	BC849A	191
BC859B	●	-	-	-	4B	4BR	PNP	BC559B, BCY79	BC849B	191
BC859C	●	-	-	-	4C	4CR	PNP	BC559C, BCY79	BC849C	191
BC860A	●	-	-	-	4E	4ER	PNP	BC560A, BCY79	BC850B	191
BC860B	●	-	-	-	4F	4FR	PNP	BC560B, BCY79	BC850C	191
BC860C	●	-	-	-	4G	4GR	PNP	BC560C, BCY79	BC869	201
BC868	-	●	-	-	CAC		NPN	BC368, BD329	BC868	207
BC869	-	●	-	-	CEC		PNP	BC369, BD330		
BCF29	●	-	-	-	C7	C77	PNP	BC559A, BCY78, BC179	BCF32	213
BCF30	●	-	-	-	C8	C9	PNP	BC559B, BCY78	BCF30	221
BCF32	●	-	-	-	D7	D77	NPN	BC549B, BCY58, BC109		221
BCF33	●	-	-	-	D8	D81	NPN	BC549C, BCY58		221
BCF70	●	-	-	-	H7	H71	PNP	BC560B, BCY79		229

TYPE NUMBER SURVEY

type number	SOT-23	SOT-89	SOT-143	SOD-80	marking		device type	nearest conventional type(s)	complement	page
					type	reverse type				
BCF81	●	-	-	-	K9	K91	NPN	BC550C		237
BCV26	●	-	-	-	FD		PNP	BC516	BCV27	241
BCV27	●	-	-	-	FF		NPN	BC517	BCV26	243
BCV61	-	●	-	-	D91		NPN	BC547	BCV62	245
BCV62	-	●	-	-	C91		PNP	BC557	BCV61	249
BCV63	-	-	●	-			NPN		BCV64	253
BCV64	-	-	●	-			PNP		BCV63	257
BCV65	-	-	●	-			PNP/NPN			261
BCV71	●	-	-	-	K7	K71	NPN	BC546A	BCW89	265
BCV72	●	-	-	-	K8	K81	NPN	BC546B		265
BCW29	●	-	-	-	C1	C4	PNP	BC178A, BC558A	BCW31	269
BCW30	●	-	-	-	C2	C5	PNP	BC178B, BC558B	BCW32	269
BCW31	●	-	-	-	D1	D4	NPN	BC108A, BC548A	BCW29	277
BCW32	●	-	-	-	D2	D5	NPN	BC108B, BC548B	BCW30	277
BCW33	●	-	-	-	D3	D6	NPN	BC108C, BC548C		277
BCW60A	●	-	-	-	AA		NPN	BC548A	BCW61A	285
BCW60B	●	-	-	-	AB		NPN	BC548B	BCW61B	285
BCW60C	●	-	-	-	AC		NPN	BC548B	BCW61C	285
BCW60D	●	-	-	-	AD		NPN	BC548C	BCW61D	285
BCW61A	●	-	-	-	BA		PNP	BC558A	BCW60A	289
BCW61B	●	-	-	-	BB		PNP	BC558B	BCW60B	289
BCW61C	●	-	-	-	BC		PNP	BC558B	BCW60C	289
BCW61D	●	-	-	-	BD		PNP	BC558C	BCW60D	289
BCW69	●	-	-	-	H1	H4	PNP	BC557A	BCW71	293
BCW70	●	-	-	-	H2	H5	PNP	BC557B	BCW72	293
BCW71	●	-	-	-	K1	K4	NPN	BC547A	BCW69	301
BCW72	●	-	-	-	K2	K5	NPN	BC547B	BCW70	301
BCW81	●	-	-	-	K3	K31	NPN	BC547C		309
BCW89	●	-	-	-	H3	H31	PNP	BC556A	BCV71	313
BCX17	●	-	-	-	T1	T4	PNP	BC327	BCX19	317
BCX18	●	-	-	-	T2	T5	PNP	BC328	BCX20	317
BCX19	●	-	-	-	U1	U4	NPN	BC337	BCX17	323
BCX20	●	-	-	-	U2	U5	NPN	BC338	BCX18	323
BCX51	-	●	-	-	AA		PNP	BC636, BD136	BCX54	329
BCX52	-	●	-	-	AE		PNP	BC638, BD138	BCX55	329
BCX53	-	●	-	-	AH		PNP	BC640, BD140	BCX56	329
BCX54	-	●	-	-	BA		NPN	BC635, BD135	BCX51	333
BCX55	-	●	-	-	BE		NPN	BC637, BD137	BCX52	333
BCX56	-	●	-	-	BH		NPN	BC639, BD139	BCX53	333
BCX70G	●	-	-	-	AG		NPN	BC107A, BC547A	BCX71G	337

TYPE NUMBER SURVEY

type number	SOT-23	SOT-89	SOT-143	SOD-80	marking type reverse type	device type	nearest conventional type(s)	complement	page
BCX70H	●	-	-	-	AH	NPN	BC107B, BC547B	BCX71H	337
BCX70J	●	-	-	-	AJ	NPN	BC107B, BC547B	BCX71J	337
BCX70K	●	-	-	-	AK	NPN	BC107C, BC547C	BCX71K	337
BCX71G	●	-	-	-	BG	PNP	BC177A, BC557A	BCX70G	341
BCX71H	●	-	-	-	BH	PNP	BC177B, BC557B	BCX70H	341
BCX71J	●	-	-	-	BJ	PNP	BC177B, BC557B	BCX70J	341
BCX71K	●	-	-	-	BK	PNP	BC557C	BCX70K	341
BF510	●	-	-	-	S6	FET	BF410A		345
BF511	●	-	-	-	S7	FET	BF410B		345
BF512	●	-	-	-	S8	FET	BF410C		345
BF513	●	-	-	-	S9	FET	BF410D		345
BF536	●	-	-	-	G3	PNP	BF936		351
BF550	●	-	-	-	G2	G5 PNP	BF450		355
BF569	●	-	-	-	G6	PNP	BF970		359
BF570	●	-	-	-	B26	NPN	BF370		363
BF579	●	-	-	-	G7	PNP	BF979		367
BF620	-	●	-	-	DC	NPN	BF420, BF471, BF871	BF621	371
BF621	-	●	-	-	DF	PNP	BF421, BF472, BF872	BF620	375
BF622	-	●	-	-	DA	NPN	BF422, BF469, BF869	BF623	371
BF623	-	●	-	-	DB	PNP	BF423, BF470, BF870	BF622	375
BF660	●	-	-	-	G8	G81 PNP	BF606A		379
BF767	●	-	-	-	G9	PNP	BF967		383
BF820	●	-	-	-	1V	NPN	BF420	BF821	387
BF821	●	-	-	-	1W	PNP	BF421	BF820	393
BF822	●	-	-	-	1X	NPN	BF422	BF823	387
BF823	●	-	-	-	1Y	PNP	BF423	BF822	393
BF824	●	-	-	-	F8	PNP	BF324		399
BF840	●	-	-	-	F3	NPN	BF240		405
BF841	●	-	-	-	F31	NPN	BF241		405
BF989	-	-	●	-	M89	FET	BF960		407
BF990	-	-	●	-	M90	FET	BF980		409
BF991	-	-	●	-	M91	FET	BF981		413
BF992	-	-	●	-	M92	FET	BF982		415
BF994	-	-	●	-	M94	FET	BF964		417
BF994S	-	-	●	-	M93	FET	BF964S		421
BF996	-	-	●	-	M96	FET	BF966		423
BF996S	-	-	●	-	M95	FET	BF966S		427
BF997	-	-	●	-	M83	FET			429
BFG67	-	-	●	-	V3	NPN	BFG65		433
BFQ17	-	●	-	-	FA	NPN	BFW16A		437

TYPE NUMBER SURVEY

type number	SOT-23	SOT-89	SOT-143	SOD-80	marking		device type	nearest conventional type(s)	complement	page
					type	reverse type				
BFQ18A	-	●	-	-	FF		NPN	BFQ34		441
BFQ19	-	●	-	-	FB		NPN	BFR96		445
BFQ67	●	-	-	-	V2		NPN	BFQ65		449
BFR30	●	-	-	-	M1		FET	BFW11, BF245		453
BFR31	●	-	-	-	M2		FET	BFW12, BF245		453
BFR53	●	-	-	-	N1	N4	NPN	BFW30, BFW93		463
BFR92	●	-	-	-	P1	P4	NPN	BFR90	BFT92	473
BFR92A	●	-	-	-	P2	P5	NPN	BFR90		483
BFR93	●	-	-	-	R1	R4	NPN	BFR91	BFT93	495
BFR93A	●	-	-	-	R2	R5	NPN	BFR91		505
BFR101A	-	-	●	-	M97		FET	-		517
BFR101B	-	-	●	-	M98		FET	-		517
BFS17	●	-	-	-	E1	E4	NPN	BFY90, BFW92		519
BFS18	●	-	-	-	F1	F4	NPN	BF185, BF495		525
BFS19	●	-	-	-	F2	F5	NPN	BF184, BF494		525
BFS20	●	-	-	-	G1	G4	NPN	BF199		531
BFT25	●	-	-	-	V1	V4	NPN	BFT24		537
BFT46	●	-	-	-	M3		FET	BFW13, BF245		545
BFT92	●	-	-	-	W1	W4	PNP	BFQ51; 52	BFR92	553
BFT93	●	-	-	-	X1	X4	PNP	BFQ23; 24	BFR93	559
BRY61	●	-	-	-	A5		PNPN	BRY56, BRY39		565
BRY62	●	-	-	-	A51		PNPN	BRY39		571
BSD20	-	●	-	-	M31		FET	-		577
BSD22	-	●	-	-	M32		FET	-		577
BSR12	●	-	-	-	B5	B8	PNP	2N2894A	BSV52	581
BSR13	●	-	-	-	U7	U71	NPN	2N2222, PH2222	BSR15	587
BSR14	●	-	-	-	U8	U81	NPN	2N2222A, PH2222A	BSR16	587
BSR15	●	-	-	-	T7	T71	PNP	2N2907, PH2907	BSR13	593
BSR16	●	-	-	-	T8	T81	PNP	2N2907A, PH2907A	BSR14	593
BSR17	●	-	-	-	U9	U91	NPN	2N3903	BSR18	599
BSR17A	●	-	-	-	U92	U93	NPN	2N3904	BSR18A	599
BSR18	●	-	-	-	T9	T91	PNP	2N3905	BSR17	603
BSR18A	●	-	-	-	T92	T93	PNP	2N3906	BSR17A	603
BSR19	●	-	-	-	U35		NPN	2N5550	BSR20	607
BSR19A	●	-	-	-	U36		NPN	2N5551	BSR20A	607
BSR20	●	-	-	-	T35		PNP	2N5400	BSR19	611
BSR20A	●	-	-	-	T36		PNP	2N5401	BSR19A	611
BSR30	-	●	-	-	BR1		PNP	2N4030	BSR40	615
BSR31	-	●	-	-	BR2		PNP	2N4032	BSR41	615
BSR32	-	●	-	-	BR3		PNP	2N4031	BSR42	615

TYPE NUMBER SURVEY

type number	SOT-23	SOT-89	SOT-143	SOD-80	marking type		device type	nearest conventional type(s)	complement	page
						reverse type				
BSR33	-	•	-	-	BR4		PNP	2N4033	BSR43	615
BSR40	-	•	-	-	AR1		NPN	BSX46-6	BSR30	619
BSR41	-	•	-	-	AR2		NPN	BSX46-16	BSR31	619
BSR42	-	•	-	-	AR3		NPN	2N3020	BSR32	619
BSR43	-	•	-	-	AR4		NPN	2N3019	BSR33	619
BSR56	•	-	-	-	M4		FET	2N4856		623
BSR57	•	-	-	-	M5		FET	2N4857		623
BSR58	•	-	-	-	M6		FET	2N4858		623
BSS63	•	-	-	-	T3	T6	PNP	BSS68	BSS64	627
BSS64	•	-	-	-	U3	U6	NPN	BSS38	BSS63	633
BSS83	-	-	•	-	M74		FET			637
BST15	-	•	-	-	BT1		PNP	2N5415	BST40	641
BST16	-	•	-	-	BT2		PNP	2N5416	BST39	641
BST39	-	•	-	-	AT1		NPN	2N3439	BST16	645
BST40	-	•	-	-	AT2		NPN	2N3440	BST15	645
BST50	-	•	-	-	AS1		NPN	BSR50, BSS50, BDX42		649
BST51	-	•	-	-	AS2		NPN	BSR51, BSS51, BDX43		649
BST52	-	•	-	-	AS3		NPN	BSR52, BSS52, BDX44		649
BST60	-	•	-	-	BS1		PNP	BSR60, BSS60, BDX45		653
BST61	-	•	-	-	BS2		PNP	BSR61, BSS61, BDX46		653
BST62	-	•	-	-	BS3		PNP	BSR62, BSS62, BDX47		653
BST80	-	•	-	-	KM		FET	BST70A		657
BST82	•	-	-	-	O2		FET	BST72A		661
BST84	-	•	-	-	KN		FET	BST74A		665
BST86	-	•	-	-	KO		FET	BST76A		669
BST120	-	•	-	-	LM		FET			673
BST122	-	•	-	-	LN		FET			677
BSV52	•	-	-	-	B2	B3	NPN	PH2369, BSX20	BSR12	681
BYD17	}	SOD-87					diode			689
BYD37							diode			693
BZD27							diode			697
BZV49	-	•	-	-	*		diode	BZV85		701
BZV55	-	-	-	•			diode	BZX79, BZX55		711
BZX84	•	-	-	-	*		diode	BZX79, BZX55		725
PMBF4391	•	-	-	-	M62		FET	2N4301		735
PMBF4392	•	-	-	-	M63		FET	2N4392		735
PMBF4393	•	-	-	-	M64		FET	2N4393		735
PMBT2222	•	-	-	-	P1B		NPN	2N2222	PMBT2907	739
PMBT2222A	•	-	-	-	P1P		NPN	2N2222A	PMBT2907A	739
PMBT2907	•	-	-	-	P2B		PNP	2N2907	PMBT2222	743
PMBT2907A	•	-	-	-	P2F		PNP	2N2907A	PMBT2222A	743

* For marking of these types see page 20.

type number	SOT-23	SOT-89	SOT-143	SOT-80	marking type	reverse type	device type	nearest conventional type(s)	complement	page
PMBT3903	●	-	-	-	P1Y		NPN	2N3903	PMBT3905	749
PMBT3904	●	-	-	-	P1A		NPN	2N3904	PMBT3906	749
PMBT3906	●	-	-	-	P2A		PNP	2N3906	PMBT3904	753
PMBT6428	●	-	-	-	P1K		NPN	2N6428		757
PMBT6429	●	-	-	-	P1L		NPN	2N6429		757
PMBTA05	●	-	-	-	P1H		NPN	MPSA05	PMBTA55	761
PMBTA06	●	-	-	-	P1G		NPN	MPSA06	PMBTA56	761
PMBTA13	●	-	-	-	P1M		NPN	MPSA13	PMBTA63	763
PMBTA14	●	-	-	-	P1N		NPN	MPSA14	PMBTA64	763
PMBTA42	●	-	-	-	P1D		NPN	MPSA42	PMBTA94	765
PMBTA43	●	-	-	-	P1E		NPN	MPSA43	PMBTA93	765
PMBTA55	●	-	-	-	P2G		NPN	MPSA55	PMBTA05	769
PMBTA56	●	-	-	-	P2H		NPN	MPSA56	PMBTA06	769
PMBTA63	●	-	-	-	P2U		PNP	MPSA63	PMBTA13	771
PMBTA64	●	-	-	-	P2V		PNP	MPSA63	PMBTA14	771
PMBTA92	●	-	-	-	P2D		PNP	MPSA92	PMBTA42	773
PMBTA93	●	-	-	-	P2E		PNP	MPSA93	PMBTA43	773
PMLL5225B to								1N5225B to		775
PMLL5267B	-	-	-	●			diode	1N5267B		
PXT3904	-	●	-	-	P1A		NPN	2N3904	PXT3906	779
PXT3906	-	●	-	-	P2A		PNP	2N3906	PXT3904	783

TYPE NUMBER SURVEY

type	BZV49- SOT-89 diode nearest conventional type	page 701	BZX84- SOT-23 diode BZX79 series	page 725
type number suffix	mark		mark	
C2V4	2Y4		Z11	
C2V7	2Y7		Z12	
C3V0	3Y0		Z13	
C3V3	3Y3		Z14	
C3V6	3Y6		Z15	
C3V9	3Y9		Z16	
C4V3	4Y3		Z17	
C4V7	4Y7		Z1	
C5V1	5Y1		Z2	
C5V6	5Y6		Z3	
C6V2	6Y2		Z4	
C6V8	6Y8		Z5	
C7V5	7Y5		Z6	
C8V2	8Y2		Z7	
C9V1	9Y1		Z8	
C10	10Y		Z9	
C11	11Y		Y1	
C12	12Y		Y2	
C13	13Y		Y3	
C15	15Y		Y4	
C16	16Y		Y5	
C18	18Y		Y6	
C20	20Y		Y7	
C22	22Y		Y8	
C24	24Y		Y9	
C27	27Y		Y10	
C30	30Y		Y11	
C33	33Y		Y12	
C36	36Y		Y13	
C39	39Y		Y14	
C43	43Y		Y15	
C47	47Y		Y16	
C51	51Y		Y17	
C56	56Y		Y18	
C62	62Y		Y19	
C68	68Y		Y20	
C75	75Y		Y21	

CONVERSION LIST

(conventional type number to SMD type number)

conventional type	microminiature type	conventional type	microminiature type	conventional type	microminiature type
BA314	BAS17	BC177	BC857	BC517	BCV27
BA480	BAT17		BCW69/70	BC546	BC846
BA482	BA682	BC177A	BC857A		BCV71/72
BA483	BA683		BCW69	BC546A	BC846A
BAT85	BAT54	BC177B	BC857B		BCV71
	BAT74		BCW70	BC546B	BC846B
BAV10	BAS56	BC178	BC858		BCV72
BAV18	BAV100		BCW29/30	BC547	BC847
BAV19	BAS19	BC178A	BC858A		BCW71/71/81
	BAV101		BCW29	BC547A	BC847A
BAV20	BAS20	BC178B	BC858B		BCW71
	BAV102		BCW30	BC547B	BC847B
BAW62	BAS16	BC179	BC859		BCW72
	BAS28		BCF29/30	BC547C	BC847C
	BAS32	BC179A	BC859A		BCW81
	BAV70		BCF29	BC548	BC848
	BAV99	BC179B	BC859B		BCW31-33
	BAW56		BCF30	BC548A	BC848A
BAX12	BAS29	BC200/01	BC859B		BCW31
	BAS31		BCF29	BC548B	BC848B
	BAS35	BC200/02	BC859B/C		BCW32
BB405	BBY31		BCF29/30	BC548C	BC848C
BB809	BBY40	BC200/03	BC859C		BCW33
BC107	BC847		BCF30	BC549	BC849
	BCW71/72	BC327	BC807		BCF32/33
BC107A	BC847A		BCX17	BC549B	BC849B
	BCW71	BC327-16	BC807-16		BCF32
BC107B	BC847B	BC327-25	BC807-25	BC549C	BC849C
	BCW72	BC327-40	BC807-40		BCF33
BC108	BC848	BC327A		BC550	BC850
	BCW31-33		BC808		BCF81
BC108A	BC848A	BC328-16	BC808-16	BC550B	BC850B
	BCW31	BC328-25	BC808-25	BC550C	BC850C
BC108B	BC848B	BC328-40	BC808-40	BC556	BC856
	BCW32	BC337	BC817		BCW89
BC109	BC849		BCX19	BC556A	BC856A
	BCF32/33	BC337-16	BC817-16		BCW89
BC109B	BC849B	BC337-25	BC817-25	BC556B	BC856B
	BCF32	BC337-40	BC817-40	BC557	BC857
BC109C	BC849C	BC338	BC818		BCW69/70
	BCFC33		BCX20	BC557A	BC857A
BC146/01	BC849B	BC338-16	BC818-16		BCW69
	BCF32	BC338-25	BC818-25	BC557B	BC857B
BC146/02	BC849B/C	BC338-40	BC818-40		BCW70
	BCF32/33	BC368	BC868	BC557C	BC857C
BC146/03	BC849C	BC369	BC869	BC558	BC858
	BCF33	BC516	BCV26		BCW29/30

CONVERSION LIST

conventional type	microminiature type	conventional type	microminiature type	conventional type	microminiature type
BC558A	BC858A	BCY58-IX	BC849B	BD138-16	BCX52-16
	BCW29		BCW60C	BD139	BCX56
BC558B	BC858B	BCY58-X	BC849C	BD139-6	BCX56-6
	BCW30		BCW60D	BD139-10	BCX56-10
BC558C	BC858C	BCY59	BC850	BD139-16	BCX56-16
BC559	BC859		BCX70 fam.	BD140	BCX53
	BCF29/30	BCY59-VII	BCX70G	BD140-6	BCX53-6
BC559A	BC859A	BCY59-VIII	BC850B	BD140-10	BCX53-10
	BCF29		BCX70H	BD140-16	BCX53-16
BC559B	BC859B	BCY59-IX	BC850B	BDX42	BST50
	BCF30		BCX70J	BDX43	BST51
BC559C	BC859C	BCY59-X	BC850C	BDX44	BST52
BC560	BC860		BCX70K	BDX45	BST60
	BCF70	BCY70	BC860	BDX46	BST61
BC560A	BC860A		BCF70	BDX47	BST61
BC560B	BC860B	BCY71	BC860	BF198	
	BCF70		BCF70	BF199	BFS20
BC560C	BC860C	BCY72	BC859	BF240	BF840
BC635	BCX54		BCF29/30	BF241	BF841
BC635-6	BCX54-6	BCY78	BC859	BF324	BF824
BC635-10	BCX54-10		BCW61 fam.	BF370	BSV52
BC635-16	BCX54-16	BCY78-VII	BC859A		BF570
BC636	BCX51		BCW61A	BF410A	BF510
BC636-6	BCX51-6	BCY78-VIII	BC859A/B	BF410B	BF511
BC636-10	BCX51-10		BCW61B	BF410C	BF512
BC636-16	BCX51-16	BCY78-IX	BC859B	BF410D	BF513
BC637	BCX55		BCW61C	BF419	BST40
BC637-6	BCX55-6	BCY78-X	BV859C	BF420	BF620
BC637-10	BCX55-10		BCW61D		BF820
BC637-16	BCX55-16	BCY79	BC860	BF421	BF621
BC638	BCX52		BCX71 fam.		BF821
BC638-6	BCX52-6	BCY79-VII	BC860A	BF422	BF622
BC638-10	BCX52-10		BCX71G		BF822
BC638-16	BCX52-16	BCY79-VIII	BC860A/B	BF423	BF623
BC639	BCX56		BCX71H		BF823
BC639-6	BCX56-6	BCY79-IX	BC860B	BF450	BF550
BC639-10	BCX56-10		BCX71J	BF451	
BC639-16	BCX56-16	BD135	BCX54	BF457	BST40
BC640	BCX53	BD135-6	BCX54-6	BF458	BST40
BC640-6	BCX53-6	BD135-10	BCX54-10	BF459	BST39
BC640-10	BCX53-10	BD135-16	BCX54-16	BF469	BF622
BC640-16	BCX53-16	BD136	BCX51	BF470	BF623
BCY56	BC850B	BD136-6	BCX51-6	BF471	BF620
	BCF70	BD136-10	BCX51-10	BF472	BF621
BCY57	BC849	BD136-16	BCX51-16	BF494	BFS19
	BCF32/33	BD137	BCX55	BF494B	BFS19
BCY58	BC849	BD137-6	BCX55-6	BF495	BFS18
	BCW60 fam.	BD137-10	BCX55-10	BF495C	BFS18
BCY58-VII	BCW60A	BD137-16	BCX55-16	BF495D	BFS18
BCY58-VIII	BC849B	BD138	BCX52	BF606A	BF660
	BCW60B	BD138-6	BCX52-6	BF819	BST40
		BD138-10	BCX52-10	BF857	BST40

conventional type	microminiature type	conventional type	microminiature type	conventional type	microminiature type
BF858	BST40	BFY52	BSR40	MPSA14	PMBTA14
BF859	BST39	BFY55	BSR40	MPSA42	PMBTA42
BF869	BF622	BFY90	BFS17	MPSA43	PMBTA43
BF870	BF623	BR101	BRY62	MPSA55	PMBTA55
BF871	BF620	BRY39	BRY62	MPSA56	PMBTA56
BF872	BF621	BRY56	BRY61	MPSA63	PMBTA63
BF926	BF660	BSR50	BST50	MPSA92	PMBTA92
BF936	BF536	BSR51	BST51	MPSA93	PMBTA93
BF939		BSR52	BST52	PH2222	BSR13
BF960	BF989	BSR60	BST60	PH2222A	BSR14
BF964	BF994	BSR61	BST61	PH2369	BSV52
	BF994S	BSR62	BST62	PH2907	BSR15
BF966	BF996	BSS38	BSS64	PH2907A	BSR16
	BF996S	BSS50	BST50	1N4148	BAS16
BF967	BF767	BSS51	BST51		BAV90
BF970	BF569	BSS52	BST52		BAV99
BF979	BF579	BSS60	BST60		BAW56
BF980	BF990	BSS61	BST61	1N5225B	PMLL5225B
BF981	BF991	BSS62	BST62	to	to
BF982	BF992	BSS68	BSS63	1N5267B	PMLL5267B
BFG65	BFG67	BSV15	BSR30/31	2N929	BC850
BFQ23	BFT93	BSV15-6	BSR30	2N930	BNC850
BFQ24	BFT93	BSV15-10	BSR30/31		BCF81
BFQ34	BFQ18A	BSV15-16	BSR31	2N1613	BSR40
BFQ34T	BFQ18A	BSV16	BSR30/31	2N1711	BSR41
BFQ51	BFT92	BSV16-6	BSR30	2N1893	BSR42
BFQ52	BFT92	BSV16-10	BSR30/31	2N2219	BSR13
BFQ65	BFQ67	BSV16-16	BSR31	2N2219A	BSR14
BFR54	BSV52	BSV17	BSR32/33	2N2222	BSR13
BFR90	BFR92A	BSV17-6	BSR32		PMBT2222
BFR91	BFR93A	BSV17-10	BSR32/33	2N2222A	BSR14
BFR96	BFQ19	BSX19	BSV52		PMBT2222A
BFR96S	BFQ19	BSX20	BSV52	2N2297	BSR40
BFT24	BFT25	BSX45	BSR40/41	2N2368	BSV52
BFT44	BST16	BSX45-6	BSR40	2N2369	BSV52
BFT45	BST15/16	BSX45-10	BSR40/41	2N2369A	BSV52
BFW11	BFR30	BSX45-16	BSR41	2N2483	BC850B
BFW12	BFR31	BSX46	BSR40/41	2N2484	BC850B/C
BFW13	BFT46	BSX46-6	BSR40	2N894A	BSR12
BFW16A	BFQ17	BSX46-10	BSR40/41	2N2905	BSR15
BFW30	BFR53	BSX46-16	BSR41	2N2905A	BSR16
BFW92	BFS17	BSX47	BSR42/43	2N2907	BSR15
BFW93	BFR53	BSX47-6	BSR42		PMBT2907
BFX29	BSR16	BSX47-10	BSR42/43	2N2907A	BSR16
BFX30	BSR16	BSY95A	BSV52		PMBT2907A
BFX84	BSR40	BZX55	BZX84	2N3019	BSR43
BFX85	BSR41	BZX79	BZX84	2N3020	BSR42
BFX86	BSR41		BZV55	2N3053	BSR40/41
BFX87	BSR16	BZV85	BZV49	2N3903	BSR17
BFX88	BSR15	MPSA05	PMBTA05		PMBT3903
BFY50	BSR40	MPSA06	PMBTA06	2N3904	BSR17A
BFY51	BSR40	MPSA13	PMBTA13		PMBT3904

CONVERSION LIST

conventional type	microminiature type
2N3905	BSR18
2N3906	BSR18A
	PMBT3906
2N4030	BSR30
2N4031	BSR32
2N4032	BSR31
2N4033	BSR33
2N4123	BSR17
2N4124	BSR18
2N4856	BSR56
2N4857	BSR57
2N4858	BSR58
2N5415	BST15
2N5416	BST16
2N6428	PMBT6428
2N6429	PMBT6429

MARKING LIST

Types in SOT-23, SOT-89 and SOT-143 envelopes are marked with a code as listed below.
The actual type number and data code are on the packing.

Types in SOT-89 usually have the type number marked in full on the envelope. An exception to this is the BZV-49 series.

The envelope number is mentioned in those cases where the same marking code appears twice.

mark	type no.	mark	type no.	mark	type no.	mark	type no.
AT1	BST39	BE	BCX55	A2	BAT18	AD	BCX51-16
AT2	BST40	BF	BCX55-6	A3	BAT17		(SOT-89)
B1		BG	BCX71G	A4	BAV70	AE	BCX52
B2	BSV52		(SOT-23)	A5	BRY61	AF	BCX52-6
B3		BG	BCX55-10	A51	BRY62	AG	BCX70G
			(SOT-89)				
B4	BSV52R			A6	BAS16	AH	BCX70H
B5	BSR12	BH	BCX71H	A61	BAS28		(SOT-23)
B6			(SOT-23)	A7	BAV99	AH	BCX53
B7		BH	BCX56	A8	BAS19		(SOT-89)
B8	BSR12R		(SOT-89)	A81	BAS20	AJ	BCX70J
		BJ	BCX71J				(SOT-23)
			(SOT-23)	A82	BAS21		
B26	BF570			A9		AJ	BCX53-6
BA	BCW61A	BJ	BCX56-6	A91	BAS17		(SOT-89)
	(SOT-23)		(SOT-89)	AA	BCW60A	AK	BCX70K
BA	BCX54	BK	BCX71K		(SOT-23)		(SOT-23)
	(SOT-89)		(SOT-23)	AA	BCX51	AK	BCX53-10
BB	BCW61B	BK	BCX56-10		(SOT-89)		(SOT-89)
	(SOT-23)		(SOT-89)	AB	BCW60B	AL	BCX53-16
BB	BCX54-6				(SOT-23)	AM	BCX52-16
	(SOT-89)	BL	BCX56-16	AB	BCX51-6	AR1	BSR40
BC	BCW61C	BM	BCX55-16		(SOT-89)	AR2	BSR41
	(SOT-23)	BR1	BSR30	AC	BCW60C	AR3	BSR42
BC	BCX54-10	BR2	BSR31		(SOT-23)		
	(SOT-89)	BR3	BSR32	AC	BCX51-10	AR4	BSR43
BD	BCW61D	BR4	BSR33		(SOT-89)	AS1	BST50
	(SOT-23)	BS1	BST60	AD	BCW60D	AS2	BST51
BD	BCX54-16	BS2	BST61		(SOT-23)	AS3	BST52
	(SOT-89)	BS3	BST62				
		A1	BAW56				

MARKING

mark	type no.	mark	type no.	mark	type no.	mark	type no.
BT1	BST15	F3	BF840	K4	BCW71R	M9	
BT2	BST16	F31	BF841	K5	BCW72R	M90	BF990
C1	BCW29	F4	BFS18R	K6		M91	BF991
C2	BCW30	F5	BFS19R	K7	BCV71	M92	BF992
C3		F6		K71	BCV71R	M93	BF994S
C4	BCW29R	F7		K8	BCV72	M94	BF994
C5	BCW30R	F8	BF824	K81	BCV72R	M95	BF996S
C6		F9		K9	BCF81	M96	BF996
C7	BCF29	FA	BFQ17	K91	BCF81R	M97	BFR101A
C77	BCF29R	FB	BFQ19	KM	BST80	M98	BFR101B
C8	BCF30	FD	BCV26	KN	BST84	N1	BFR53
C9	BCF30R	FF	BCV27	KO	BST86	N2	
C91	BCV62	(SOT-23)		L2		N3	
CAC	BC868	FF	BFQ18A	L20	BAS29	N4	BFR53R
CEC	BC869	(SOT-89)		L21	BAS31	N5	
D1	BCW31	G1	BFS20	L22	BAS35	N6	
D2	BCW32	G2	BF550	L3		N7	
D3	BCW33	G3	BF536	L30	BAV23	N8	
D4	BCW31R	G4	BFS20R	L4	BAT54	N9	
D5	BCW32R	G5	BF550R	L41	BAT74	P1	BFR92
D6	BCW33R	G6	BF569	L5		P1A	PMBT3904
D7	BCF32	G7	BF579	L51	BAS56	P1B	PMBT2222
D77	BCF32R	G8	BF660	LM	BST120	P1D	PMBTA42
D8	BCF33	G81	BF660R	LN	BST122	P1E	PMBTA43
D81	BCF33R	G9	BF767	M1	BFR30	P1G	PMBTA05
D91	BCV61	H1	BCW69	M2	BFR32	P1H	PMBTA06
DA	BF622	H2	BCW70	M3	BFT46	P1K	PMBT6428
DB	BF623	H3	BCW89	M31	BSD20	P1L	PMBT6429
DC	BF620	H31	BCW89R	M32	BSD22	P1M	PMBTA13
DF	BF621	H4	BCW69R	M4	BSR56	P1N	PMBTA14
E1	BFS17	H5	BCW70R	M5	BSR57	P1P	PMBT2222A
E2		H6		M6	BSR58	P1Y	PMBT3903
E3		H7	BCF70	M61		P2	BFR92A
E4	BFS17R	H71	BCF70R	M62	PBMF4391	P2A	PMBT3906, PXT3906
E5		H8		M63	PBMF4392	P2B	PMBT2907, PXT3904
E6		H9		M64	PBMF4393	P2D	PMBTA92
E7		K1	BCW71	M74	BSS83	P2E	PMBTA93
E8		K2	BCW72	M8		P2F	PMBT2907A
F1	BFS18	K3	BCW81	M83	BF997	P2G	PMBTA55
F2	BFS19	K31	BCW81R	M89	BF989	P2H	PMBTA56

MARKING

mark	type no.	mark	type no.	mark	type no.	mark	type no.
P2U	PMBTA63	T93	BSR18AR	X9		1E	BC847A
P2V	PMBTA64	U1	BCX19	Y1	BZX84-C11	1ER	BC847AR
P3		U2	BCX20	Y2	-C12	1F	BC847B
P4	BFR92R	U3	BSS64	Y3	-C13	1FR	BC847BR
P5	BFR92AR	U4	BCX19R	Y4	-C15	1G	BC847C
P6		U5	BCX20R	Y5	BZX84-C16	1GR	BC847CR
P7		U6	BSS64R	Y6	-C18	1J	BC848A
P8		U7	BSR13	Y7	-C20	1JR	BC848AR
P9		U8	BSR14	Y8	-C22	1K	BC848B
R1	BFR93	U81	BSR14R	Y9	-C24	1KR	BC848BR
R2	BFR93A	U9	BSR17	Y10	BZX84-C27	1L	BC848C
R3		U91	BSR17R	Y11	-C30	1LR	BC848CR
R4	BFR93R	U92	BSR17A	Y12	-C33	1V	BF820
R5	BFR93AR	U93	BSR17AR	Y13	-C36	1W	BF821
R6		V1		Y14	-C39	1X	BF822
R7		V2	BFQ67	Y15	-C43	1Y	BF823
R8		V3	BFG67	Y16	-C47	2B	BC849B
R9		V4	BFT25R	Y17	-C51	2BR	BC849BR
S1	BBY31	V5		Y18	-C56	2C	BC849C
S2	BBY40	V6		Y19	-C62	2CR	BC849CR
S3		V7		Y20	-C68	2F	BC850B
S4		V8		Y21	-C75	2FR	BC850BR
S5		V9		Z1	-C4V7	2G	BC850C
S6	BF510	W1	BFT92	Z2	-C5V1	2GR	BC850CR
S7	BF511	W2		Z3	-C5V6	2Y4	BZV49-C2V4
S8	BF512	W3		Z4	-C6V2	2Y7	BZV49-C2V7
S9	BF513	W4	BFT92R	Z5	-C6V8	3A	BC856A
T1	BCX17	W5		Z6	-C7V5	3AR	BC856AR
T2	BCX18	W6		Z7	-C8V2	3B	BC856B
T3	BSS63	W7		Z8	-C9V1	3BR	BC856BR
T4	BCX17R	W8		Z9	-C10	3E	BC857A
T5	BCX18R	W9		Z11	-C2V4	3ER	BC857AR
T6	BSS63R	X1	BFT93	Z12	-C2V7	3F	BC857B
T7	BSR15	X2		Z13	-C3V0	3FR	BC857BR
T71	BSR15R	X3		Z14	-C3V3	3J	BC858A
T8	BSR16	X4	BFT93R	Z15	-C3V6	3JR	BC858AR
T81	BSR16R	X5		Z16	-C3V9	3G	BC857C
T9	BSR18	X6		Z17	-C4V3	3GR	BC857CR
T91	BSR18R	X7		1A	BC846A	3K	BC858B
T92	BSR18A	X8		1BR	BC846AR	3KR	BC858BR

MARKING

mark	type no.	mark	type no.	mark	type no.	mark	type no.
3L	BC858C	6E	BC818-16				
3LR	BC858CR	6ER	BC818-16R				
3Y0	BZV49-C3V0	6F	BC818-25				
3Y3	BZV49-C3V3	6FR	BC818-25R				
3Y6	BZV49-C3V6	6G	BC818-40				
3Y9	BZV49-C3V9	6GR	BC818-40R				
4A	BC859A	6Y2	BZV49-C6V2				
4AR	BC859AR	6Y8	-C6V8				
4B	BC859B	7Y5	-C7V5				
4BR	BC859BR	8Y2	-C8V2				
4C	BC859C	9Y1	-C9V1				
4CR	BC859CR	10Y	-C10				
4E	BC860A	11Y	-C11				
4ER	BC860AR	12Y	-C12				
4F	BC860B	13Y	-C13				
4FR	BC860BR	15Y	-C15				
4G	BC860C	16Y	-C16				
4GR	BC860CR	18Y	-C18				
4Y3	BZV49-C4V3	20Y	-C20				
4Y7	BZV49-C4V7	22Y	-C22				
5A	BC807-16	24Y	-C24				
5AR	BC807-16R	27Y	-C27				
5B	BC807-25	30Y	-C30				
5BR	BC807-25R	33Y	-C33				
5C	BC807-40	36Y	-C36				
5CR	BC807-40R	39Y	BZV49-C39				
5E	BC808-16	43Y	-C43				
5ER	BC808-16R	47Y	-C47				
5F	BC808-25	51Y	-C51				
5FR	BC808-25R	56Y	-C56				
5G	BC808-40	62Y	-C62				
5GR	BC808-40R	68Y	-C68				
5Y1	BZV49-C5V1	75Y	-C75				
5Y6	BZV49-C5V6						
6A	BC917-16						
6AR	BC817-16R						
6B	BC817-25						
6BR	BC817-25R						
6C	BC817-40						
6CR	BC817-40R						

TAPE AND REEL SPECIFICATION

Semiconductors in SOT-23, SOT-143 and SOT-89 encapsulations can be delivered in reel packing for automatic placement on hybrid circuits and printed circuit boards. The devices are placed with the mounting side downwards in compartments.

A separate cross-section for SOD-80 encapsulation is given in Fig. 3.

A separate reel packing for SOT-89 encapsulation is given in Fig. 4.

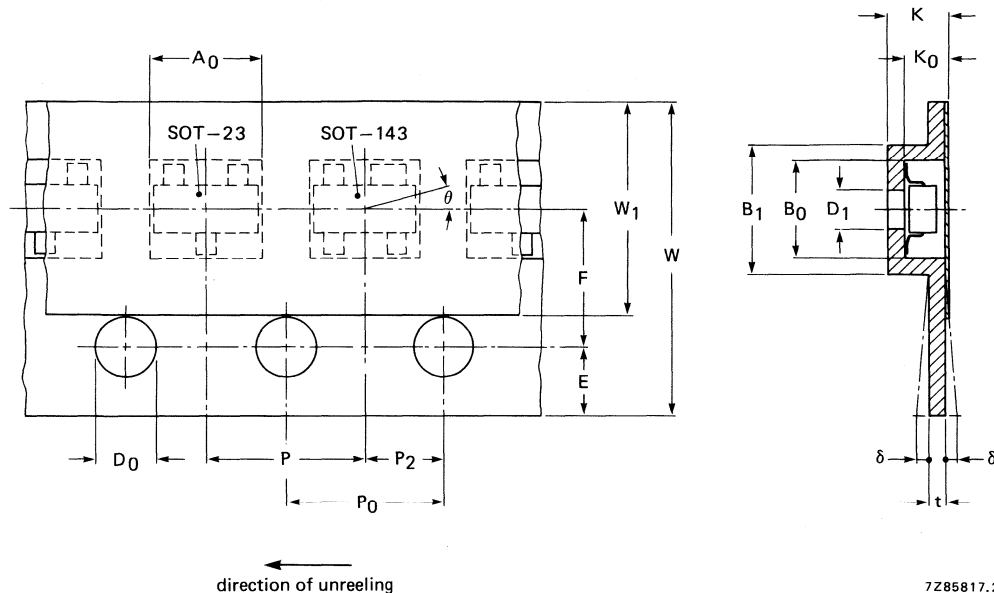
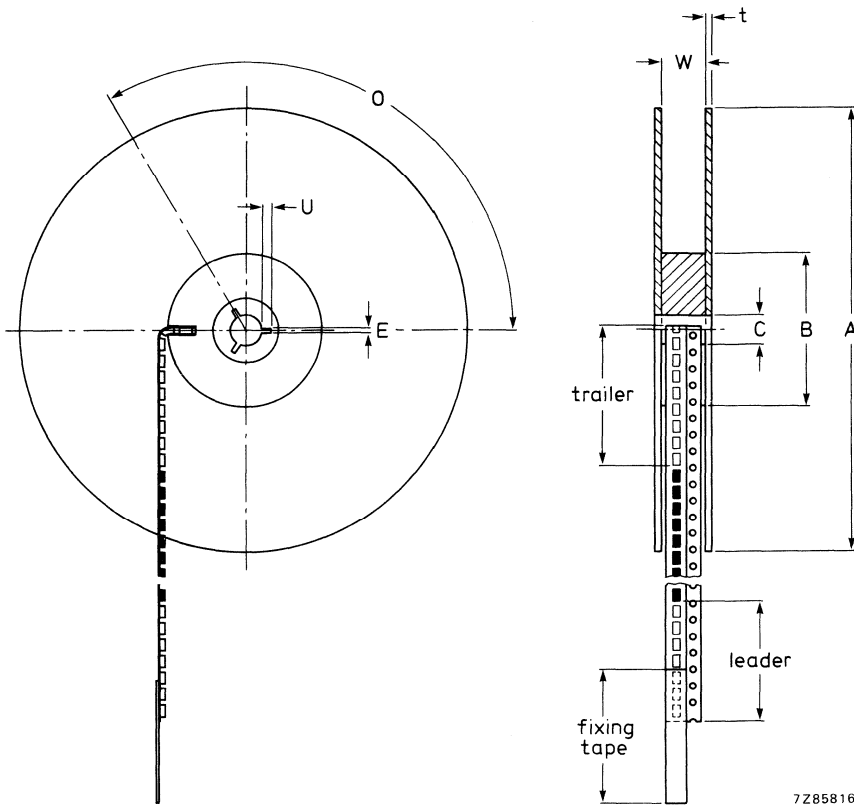

Fig. 1 Configuration of bandolier. Dimensions in mm.

Compartment		tol.		Centre line dimensions		tol.	
length	A_0	component length	+0,2	length direction	P_2	2,0	$\pm 0,05$
width	B_0	component width	+0,2	width direction	F	3,5	$\pm 0,05$
depth	K_0		0,95				
width outside	B_1		3,3				
pitch	P		4,0				
deviation	\ominus		15°				
hole diameter	D_1		1				
Sprocket hole				Fixing tape			
diameter	D_0		1,5	width	W_1	5,5	$\pm 0,25$
pitch	P_0		4,0	thickness	—	0,1	max.
distance	E		1,75	Carrier tape			
cumulative (10)				width	W	8,0	$\pm 0,2$
pitch error			$\pm 0,1$	bending	δ	0,3	max.
				thickness	t	0,4	max.
				Overall thickness			
					K	1,5	max.



7285816

Fig. 2 Configuration of reel and flange (dimensions in mm).

Flange				Hub			
diameter	A	180	tol. +0 -2	diameter	B	62	tol. ± 1,5
thickness	t	1,5	+0,5 -0,1	spindle hole	C	12,75	+0,15 -0
space between flanges	W	9,5	± 0,5	key slit			
				width	E	2	± 0,5
				depth	U	4	± 0,5
				location	O	120	degrees

Amount of devices per reel

The bandolier of a 180 mm reel contains at least 3000 devices with no more than 15 empty compartments (0,5%). Three consecutive empty places might be found provided this gap is followed by 6 consecutive devices.

The carrier tape (leader) starts with at least 75 empty positions (equivalent to 300 mm); the covering foil is at least 300 mm. In order to fix the carrier tape a self-adhesive tape of 20 to 50 mm is applied.

At the end of the bandolier (trailer) at least 75 empty positions (equivalent to a length of 300 mm) and 300 mm foil. For fixing onto the reel a self-adhesive tape of 20 to 50 mm is applied.

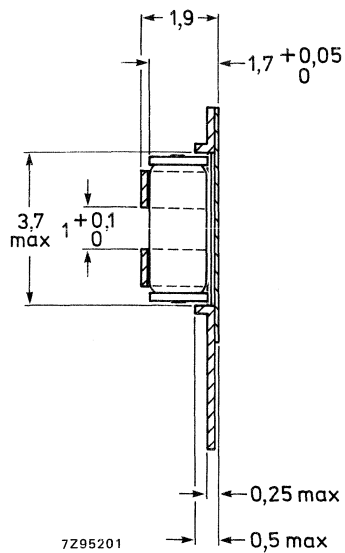

Fig. 3 Cross-sectional view of bandolier with **SOD-80** devices.

Note: Testing of **SOD-80** devices is possible in this tape. The cathode is directed towards the sprocket hole. The total number of devices per reel is 2500 for **SOD-80** and 2000 for **SOD-87**.

Semiconductors in SOT-89 encapsulations can also be delivered in reel packing for automatic placement on hybrid circuits and printed circuit boards. The devices are placed with the mounting side downwards in compartments. Total number of devices per reel is 1000.

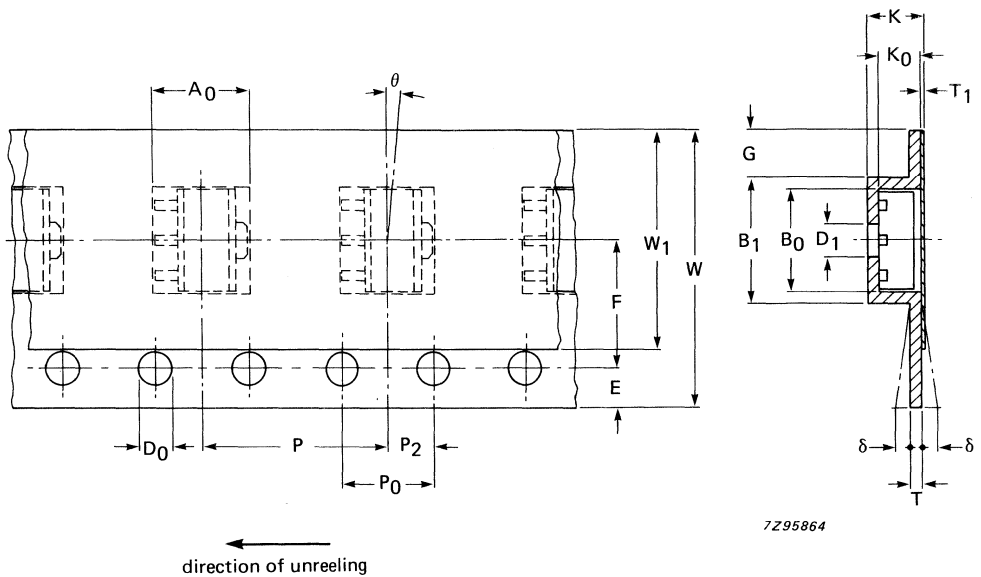

Fig. 4 Configuration of bandolier. Dimensions in mm.

Compartment		tol.		Centre line dimensions		tol.	
length	A_0 component length			length direction	P_2	2,0	$\pm 0,05$
width	B_0 component width			width direction	F	5,5	$\pm 0,1$
depth	K_0 component depth			Fixing tape			
width outside	B_1	5,7	max.	width	W_1	9,5	max.
pitch	P	8,0	$\pm 0,1$	thickness	T_1	0,1	max.
deviation	\ominus	$\pm 5^\circ$	max.	Carrier tape			
hole diam.	D_1	1,5	min.	width	W	12	$\pm 0,2$
				bending	δ	0,3	max.
Sprocket hole				thickness	T	0,4	max.
diameter	D_0	1,5	$+0,1$	Overall thickness			
pitch	P_0	4,0	$\pm 0,1$	distance	G	1,8	min.
distance	E	1,75	$\pm 0,1$				
cumulative (10)							
pitch error			$\pm 0,1$				

SOLDERING RECOMMENDATIONS

SOD80, SOD87, SOT-23, SOT143 AND SOT-89 ENVELOPES

SOT-23, SOT-143 and SOT-89 devices are ideally suited for placement onto thick and thin film substrates and printed circuit boards.

To assure reliable and consistent connections particular attention should be paid to:

1. Flux

A non-active flux is recommended. Where active fluxes are employed, great care in subsequent substrate cleaning must be exercised.

2. Metal-alloy solder or solder paste

Correct choice of solder alloy or solder paste to be employed e.g. 62% Sn, 36% Pb, 2% Ag or 60% Sn/40% Pb. Any paste used should contain at least 85% metal dry weight.

3. Soldering temperature

This will vary according to the actual method employed.

REFLOW SOLDERING

The preferred technique for mounting microminiature components on hybrid thick and thin-film is the method of reflow soldering.

The tags of SOT-23, SOT-143 and SOT-89 envelopes are pre-tinned and the best results are obtained if a similar solder is applied to the corresponding soldering areas on the substrate. This can be done by either dipping the substrate in a solder bath or by screen printing a solder paste.

The maximum temperature of the leads or tab during the soldering cycle should not exceed 285 °C. The most economic method of soldering is a process in which all different components are soldered simultaneously for example SOT-23, SOT-143 or SOT-89 devices, capacitors and resistors.

Having first been fluxed, all components are positioned on the substrate. The slight adhesive force of the flux is sufficient to keep the components in place. Solder paste contains a flux and has therefore good inherent adhesive properties which eases positioning of the components.

With the components in position the substrate is heated to a point where the solder begins to flow. This can be done on a heating plate or on a conveyor belt running through an infrared tunnel. The maximum allowed temperature of the plastic body of a device must be kept below 280 °C during the soldering cycle. For further temperature behaviour during the soldering process see Figs 2 and 3.

The surface tension of the liquid solder tends to draw the tags of the device towards the centre of the soldering area and has thus a correcting effect on slight mispositionings. However, if the layout leaves something to be desired the same effect can result in undesirable shifts; particularly if the soldering areas on the substrate and the components are not concentrically arranged. This problem can be solved using a standard contact pattern, which leaves sufficient scope for the self-positioning effect (see Figs 4 and 5).

After cooling the connections may be visually inspected and, where necessary, repaired with a light soldering iron. Finally any remaining flux must be removed carefully.

WAVE SOLDERING

The normal (dual) wave soldering process can also be applied to SOD-80, SOT-23, SOD-87 and SOT-143 envelopes. We do not recommend SOT-89 for wave soldering.

IMMERSION SOLDERING

Where a complete substrate or printed circuit board is immersed in solder:

- a. The temperature of the soldering bath should not exceed 280 °C.
- b. The duration of the soldering cycle should not exceed 10 seconds.
- c. Forced cooling may be applied (see Fig. 1).

HAND SOLDERING

It is possible to solder microminiature devices with a light hand-held soldering iron, but this method has obvious drawbacks and should therefore be restricted to laboratory use and/or incidental repairs on production circuits.

- 1. It is time-consuming and expensive.
- 2. The device cannot be positioned accurately and therefore the connecting tags may come into contact with the substrate and damage it.
- 3. There is a great risk of breaking either substrate or even internal connections inside the encapsulation.
- 4. The envelope may be damaged by the iron.

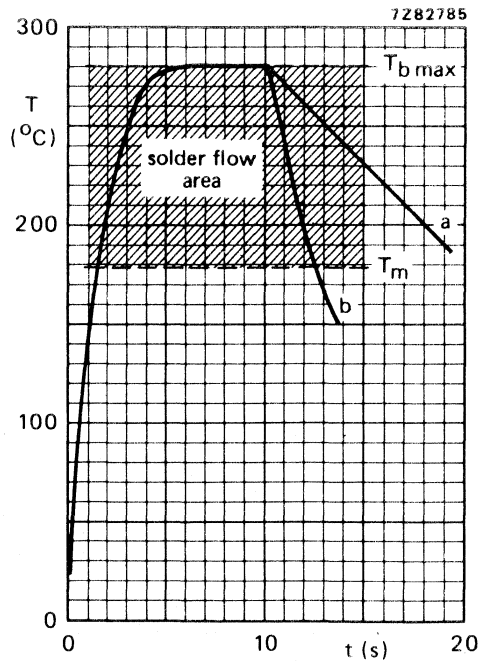

Fig. 1 Device temperature during *immersion* soldering.

Maximum time of immersion in soldering bath is 10 seconds at an ambient temperature of 25 °C.

a = free convection cooling; b = forced cooling.

$T_{b \max}$ = maximum bath temperature (280 °C).

T_m = melting temperature of solder (179 °C).

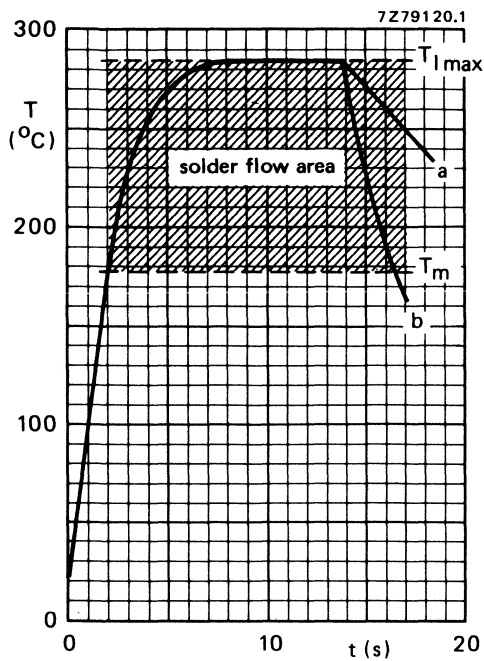

- a = free convection cooling.
- b = permissible forced cooling.
- $T_{l\ max}$ = Maximum lead or tab temperature = 285 °C.
- T_m = Melting point of the solder is 179 °C.
- T_{amb} = 25 °C.

Time of heat supply:
without preheating max. 14 s
with preheating max. 10 s
Maximum time of preheating 45 s

Fig. 2 Reflow soldering without preheating.

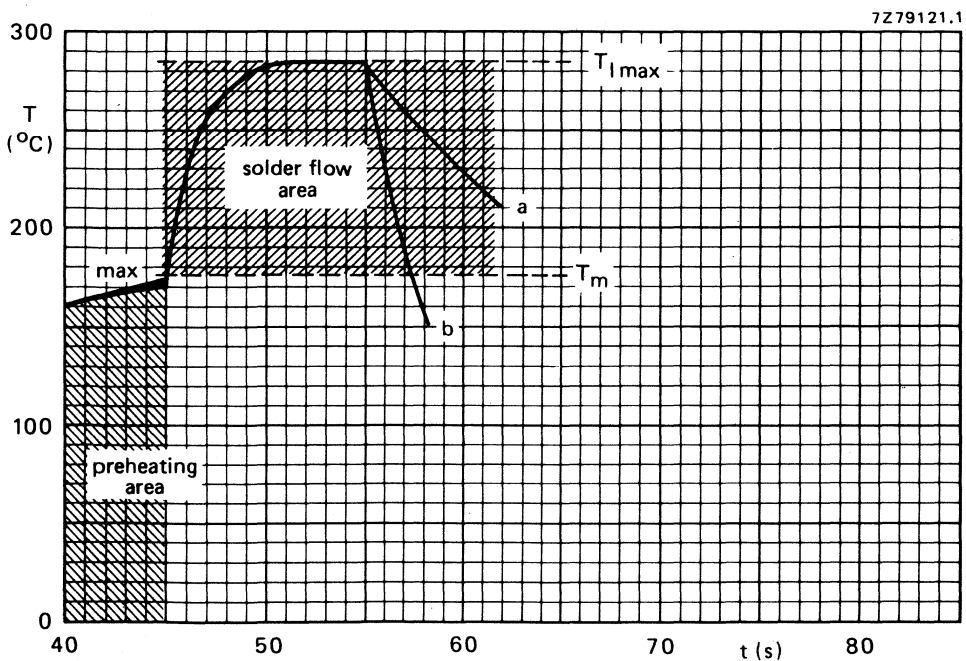

Fig. 3 Reflow soldering with preheating.

Minimum required dimensions of metal connection pads on hybrid thick and thin-film substrates.

Dimensions in mm

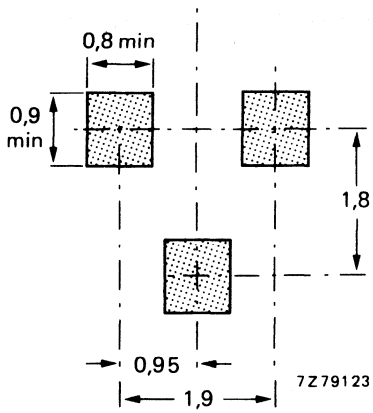

Fig. 4 SOT-23 pattern.

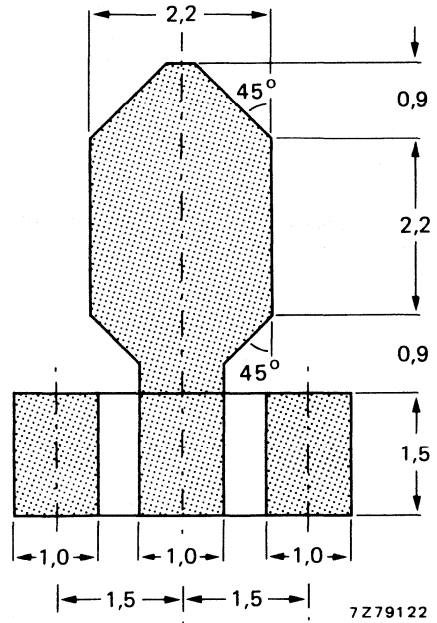

Fig. 5 SOT-89 pattern.

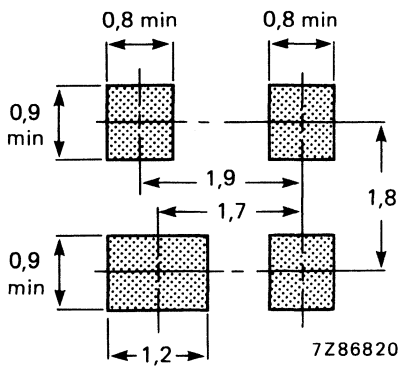

Fig. 6 SOT-143 pattern.

SOLDERING RECOMMENDATIONS SOD-80 ENVELOPE

The layout shown below is intended for use with mounting of diodes having a SOD-80 envelope onto a printed circuit board in those cases where the diode is glued to the p.c. board first and soldered afterwards.

The dimensions given may be smaller if the diode in question is not fixed to the substrate prior to soldering. The position of the SOD-80 device is then self-adjusted during the soldering process.

Dimensions in mm

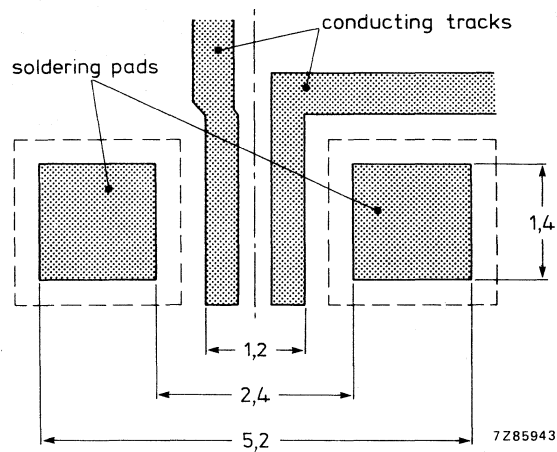

THERMAL CHARACTERISTICS FOR SOT-23 AND SOT-143 ENVELOPES

The heat generated in a semiconductor chip normally flows by various paths to the surroundings (ambient).

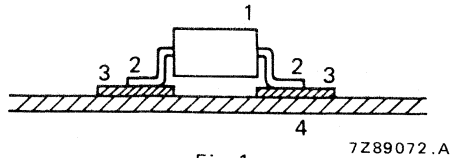

Fig. 1.

1. Heat radiation from the envelope to ambient (1).
This heat transfer can be neglected when the envelope is mounted on a substrate or printed circuit board.
2. Heat transmission via leads (2) soldering points (3) and substrate (4).

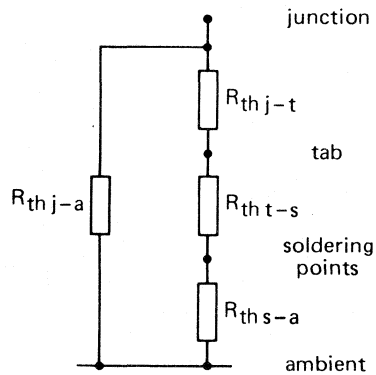

Fig. 2 Thermal behaviour of heat flow when the device is mounted on a substrate or printed circuit board.

- $R_{th\ j-t}$ = Thermal resistance from junction to tab.
 $R_{th\ t-s}$ = Thermal resistance from tab to soldering points.
 $R_{th\ s-a}$ = Thermal resistance from soldering points to ambient.
 $R_{th\ j-a}$ = Thermal resistance from junction to ambient.

Heat transfer directly from envelope to ambient

This depends on the difference between the temperatures of envelope and the surroundings. When the device is mounted on a substrate or printed circuit board direct heat flow can usually be neglected in relation to the heat flow via leads and substrate. Thus the thermal model can be as in Fig. 3.

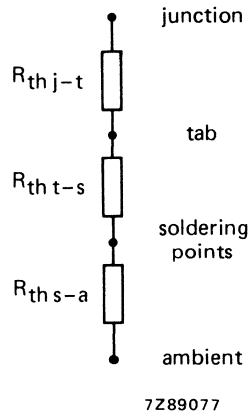

Fig. 3 Basic thermal model.

Heat transfer from junction to tab

This is an internal heat transfer and has been measured. In general it is:

- for high-frequency transistors, low-power diodes and (MOS) FETs 60 K/W
- for low-frequency and switching transistors 50 K/W
- for low-frequency medium-power transistors 30 K/W

Heat transfer from tab to soldering points

- This value has also been measured for SOT-23 with $P_{tot} < 350$ mW 280 K/W
- for types of semiconductors in this envelope with $P_{tot} < 425$ mW 260 K/W
- for types of semiconductors in a SOT-143 envelope this value is 310 K/W

Heat transfer from soldering points to ambient

This depends on the shape and material of tracks and substrate. In figures 4 and 5 standard mounting conditions are given to set up the maximum power ratings for SOT-23 and SOT-143 encapsulations.

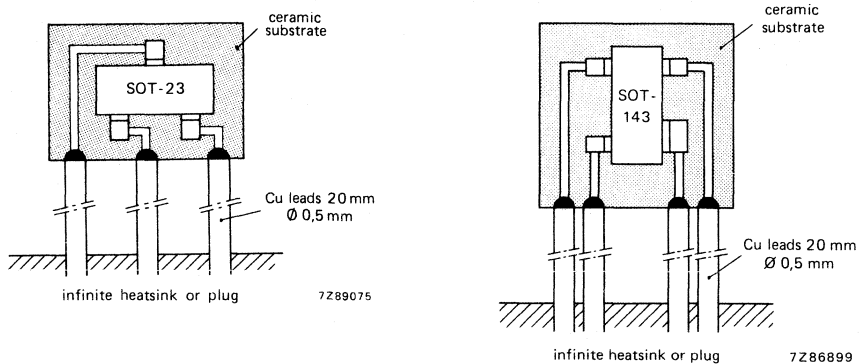

Fig. 4 Test circuits SOT-23 and SOT-143 mounting conditions on a ceramic substrate.

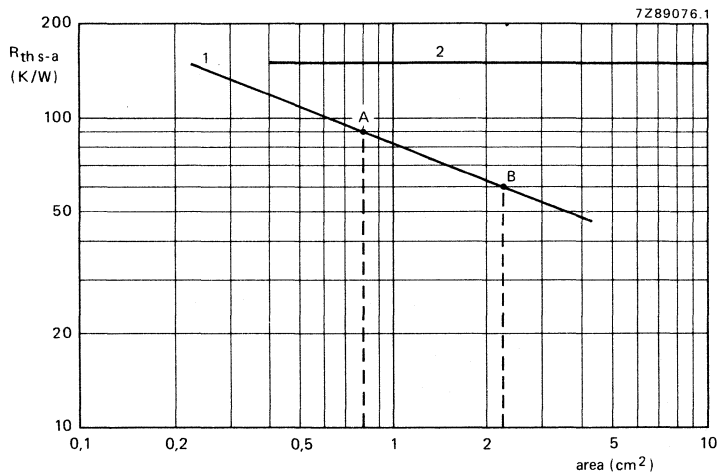

Fig. 5 Heat transfer from soldering points to ambient.

1. Ceramic substrate

Point A on the curve in Fig. 5 is for an area of the ceramic substrate of 8 mm x 10 mm x 0,7 mm for the maximum rating of all high-frequency, low-frequency and switching transistors and also for all diodes.

Point B on the curve in Fig. 5 is for an area of the ceramic substrate of 15 mm x 15 mm x 0,7 mm for the maximum rating of low-frequency medium-power semiconductors.

2. Printed circuit board

$R_{th\ s-a} = 150\ K/W$ for SOT-23 and SOT-143 envelopes mounted on a printed circuit board.

The values for the thermal resistance from junction to tab, and tab to soldering points, are given earlier and in Fig. 5.

The formula for devices in SOT-23 with one crystal can be generalized:

$$T_j = P (R_{th\ j-t} + R_{th\ t-s} + R_{th\ s-a}) + T_{amb}$$

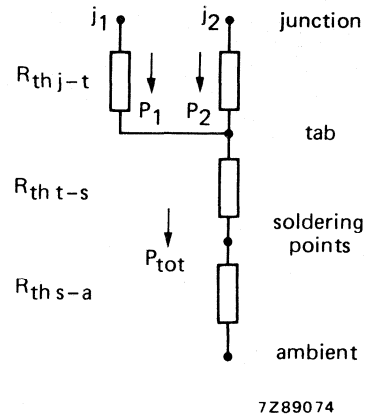
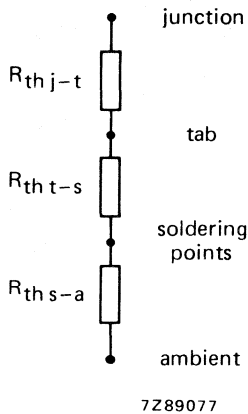

Fig. 6 Thermal model of SOT-23 envelopes with one crystal.

Fig. 7 Thermal model of SOT-23 envelopes with two crystals (double diode).

The formulae for devices with two crystals (double diodes) are:

$$T_{tab} = P_{tot} \cdot (R_{th\ t-s} + R_{th\ s-a}) + T_{amb} = P_{tot} (280 + 90) + T_{amb}$$

$$T_{j1} = (P_1 \times R_{th\ j-t}) + T_{tab} = P_1 \cdot 60 + T_{tab}$$

$$T_{j2} = (P_2 \times R_{th\ j-t}) + T_{tab} = P_2 \cdot 60 + T_{tab}$$

As mentioned with Fig. 3:

$R_{th\ j-t}$ for diodes is 60 K/W.

$R_{th\ s-a}$ (area 8 mm x 10 mm x 0,7 mm) = 90 K/W.

$R_{th\ t-s}$ for all semiconductors in SOT-23 = 280 K/W.

Thus:

$$T_{j1} = 60 P_1 + 370 P_{tot} + T_{amb}$$

$$T_{j2} = 60 P_2 + 370 P_{tot} + T_{amb}$$

GENERAL

Type designation

Rating systems

Letter symbols

s-parameters

PRO ELECTRON TYPE DESIGNATION CODE FOR SEMICONDUCTOR DEVICES

This type designation code applies to discrete semiconductor devices — as opposed to integrated circuits —, multiples of such devices and semiconductor chips.

“Although not all type numbers accord with the Pro Electron system, the following explanation is given for the ones that do.”

A basic type number consists of:

TWO LETTERS FOLLOWED BY A SERIAL NUMBER

FIRST LETTER

The first letter gives information about the material used for the active part of the devices.

- A. GERMANIUM or other material with band gap of 0,6 to 1,0 eV.
- B. SILICON or other material with band gap of 1,0 to 1,3 eV.
- C. GALLIUM-ARSENIDE or other material with band gap of 1,3 eV or more.
- R. COMPOUND MATERIALS (e.g. Cadmium-Sulphide).

SECOND LETTER

The second letter indicates the function for which the device is primarily designed.

- A. DIODE; signal, low power
- B. DIODE; variable capacitance
- C. TRANSISTOR; low power, audio frequency ($R_{th j-mb} > 15 \text{ K/W}$)
- D. TRANSISTOR; power, audio frequency ($R_{th j-mb} \leq 15 \text{ K/W}$)
- E. DIODE; tunnel
- F. TRANSISTOR; low power, high frequency ($R_{th j-mb} > 15 \text{ K/W}$)
- G. MULTIPLE OF DISSIMILAR DEVICES — MISCELLANEOUS; e.g. oscillator
- H. DIODE; magnetic sensitive
- L. TRANSISTOR; power, high frequency ($R_{th j-mb} \leq 15 \text{ K/W}$)
- N. PHOTO-COUPLER
- P. RADIATION DETECTOR; e.g. high sensitivity phototransistor
- Q. RADIATION GENERATOR; e.g. light-emitting diode (LED)
- R. CONTROL AND SWITCHING DEVICE; e.g. thyristor, low power ($R_{th j-mb} > 15 \text{ K/W}$)
- S. TRANSISTOR; low power, switching ($R_{th j-mb} > 15 \text{ K/W}$)
- T. CONTROL AND SWITCHING DEVICE; e.g. thyristor, power ($R_{th j-mb} \leq 15 \text{ K/W}$)
- U. TRANSISTOR; power, switching ($R_{th j-mb} \leq 15 \text{ K/W}$)
- X. DIODE: multiplier, e.g. varactor, step recovery
- Y. DIODE; rectifying, booster
- Z. DIODE; voltage reference or regulator (transient suppressor diode, with third letter W)

SERIAL NUMBER

Three figures, running from 100 to 999, for devices primarily intended for consumer equipment.*
One letter (Z, Y, X, etc.) and two figures, running from 10 to 99, for devices primarily intended for industrial/professional equipment.*

This letter has no fixed meaning except W, which is used for transient suppressor diodes.

VERSION LETTER

It indicates a minor variant of the basic type either electrically or mechanically. The letter never has a fixed meaning, except letter R, indicating reverse voltage, e.g. collector to case or anode to stud.

SUFFIX

Sub-classification can be used for devices supplied in a wide range of variants called associated types. Following sub-coding suffixes are in use:

1. VOLTAGE REFERENCE and VOLTAGE REGULATOR DIODES: *ONE LETTER and ONE NUMBER*

The LETTER indicates the nominal tolerance of the Zener (regulation, working or reference) voltage

A. 1% (according to IEC 63: series E96)

B. 2% (according to IEC 63: series E48)

C. 5% (according to IEC 63: series E24)

D. 10% (according to IEC 63: series E12)

E. 20% (according to IEC 63: series E6)

The number denotes the typical operating (Zener) voltage related to the nominal current rating for the whole range.

The letter 'V' is used instead of the decimal point.

2. TRANSIENT SUPPRESSOR DIODES: *ONE NUMBER*

The NUMBER indicates the maximum recommended continuous reversed (stand-off) voltage V_R . The letter 'V' is used as above.

3. CONVENTIONAL and CONTROLLED AVALANCHE RECTIFIER DIODES and THYRISTORS: *ONE NUMBER*

The NUMBER indicates the rated maximum repetitive peak reverse voltage (V_{RRM}) or the rated repetitive peak off-state voltage (V_{DRM}), whichever is the lower. Reversed polarity is indicated by letter R, immediately after the number.

4. RADIATION DETECTORS: *ONE NUMBER*, preceded by a hyphen (-)

The NUMBER indicates the depletion layer in μm . The resolution is indicated by a version LETTER.

5. ARRAY OF RADIATION DETECTORS and GENERATORS: *ONE NUMBER*, preceded by a stroke (/).

The NUMBER indicates how many basic devices are assembled into the array.

* When these serial numbers are exhausted the serial number for consumer types may be extended to four figures, and that for industrial types to three figures.

RATING SYSTEMS

The rating systems described are those recommended by the International Electrotechnical Commission (IEC) in its Publication 134.

DEFINITIONS OF TERMS USED

Electronic device. An electronic tube or valve, transistor or other semiconductor device.

Note

This definition excludes inductors, capacitors, resistors and similar components.

Characteristic. A characteristic is an inherent and measurable property of a device. Such a property may be electrical, mechanical, thermal, hydraulic, electro-magnetic, or nuclear, and can be expressed as a value for stated or recognized conditions. A characteristic may also be a set of related values, usually shown in graphical form.

Bogey electronic device. An electronic device whose characteristics have the published nominal values for the type. A bogey electronic device for any particular application can be obtained by considering only those characteristics which are directly related to the application.

Rating. A value which establishes either a limiting capability or a limiting condition for an electronic device. It is determined for specified values of environment and operation, and may be stated in any suitable terms.

Note

Limiting conditions may be either maxima or minima.

Rating system. The set of principles upon which ratings are established and which determine their interpretation.

Note

The rating system indicates the division of responsibility between the device manufacturer and the circuit designer, with the object of ensuring that the working conditions do not exceed the ratings.

ABSOLUTE MAXIMUM RATING SYSTEM

Absolute maximum ratings are limiting values of operating and environmental conditions applicable to any electronic device of a specified type as defined by its published data, which should not be exceeded under the worst probable conditions.

These values are chosen by the device manufacturer to provide acceptable serviceability of the device, taking no responsibility for equipment variations, environmental variations, and the effects of changes in operating conditions due to variations in the characteristics of the device under consideration and of all other electronic devices in the equipment.

The equipment manufacturer should design so that, initially and throughout life, no absolute maximum value for the intended service is exceeded with any device under the worst probable operating conditions with respect to supply voltage variation, equipment component variation, equipment control adjustment, load variations, signal variation, environmental conditions, and variations in characteristics of the device under consideration and of all other electronic devices in the equipment.

DESIGN MAXIMUM RATING SYSTEM

Design maximum ratings are limiting values of operating and environmental conditions applicable to a bogey electronic device of a specified type as defined by its published data, and should not be exceeded under the worst probable conditions.

These values are chosen by the device manufacturer to provide acceptable serviceability of the device, taking responsibility for the effects of changes in operating conditions due to variations in the characteristics of the electronic device under consideration.

The equipment manufacturer should design so that, initially and throughout life, no design maximum value for the intended service is exceeded with a bogey device under the worst probable operating conditions with respect to supply voltage variation, equipment component variation, variation in characteristics of all other devices in the equipment, equipment control adjustment, load variation, signal variation and environmental conditions.

DESIGN CENTRE RATING SYSTEM

Design centre ratings are limiting values of operating and environmental conditions applicable to a bogey electronic device of a specified type as defined by its published data, and should not be exceeded under normal conditions.

These values are chosen by the device manufacturer to provide acceptable serviceability of the device in average applications, taking responsibility for normal changes in operating conditions due to rated supply voltage variation, equipment component variation, equipment control adjustment, load variation, signal variation, environmental conditions, and variations in the characteristics of all electronic devices.

The equipment manufacturer should design so that, initially, no design centre value for the intended service is exceeded with a bogey electronic device in equipment operating at the stated normal supply voltage.

TRANSISTOR RATINGS

The ratings are presented as voltage, current, power and temperature ratings. The list of these ratings and their definitions is given as follows:

Transistor voltage ratings

Collector to base voltage ratings

V_{CBmax} The maximum permissible instantaneous voltage between collector and base terminals. The collector voltage is negative with respect to base in PNP transistors and positive with respect to base in NPN types.

$V_{CBmax} (I_E = 0)$ The maximum permissible instantaneous voltage between collector and base terminals, when the emitter terminal is open circuited.

Emitter to base voltage ratings

V_{EBmax} The maximum permissible instantaneous reverse voltage between emitter and base terminal. The emitter voltage is negative with respect to base for PNP transistor and positive with respect to base for NPN types.

$V_{EBmax} (I_C = 0)$ The maximum permissible instantaneous reverse voltage between emitter and base terminals when the collector terminal is open circuited.

Collector to emitter voltage ratings

V_{CEmax} The maximum permissible instantaneous voltage between collector and emitter terminals. The collector voltage is negative with respect to emitter in PNP transistors and positive with respect to emitter in NPN types. This rating is very dependent on circuit conditions and collector current and it is necessary to refer to the curve of V_{CE} versus I_C for the appropriate circuit condition in order to obtain the correct rating.

$V_{CEmax} (Cut-off)$ The maximum permissible instantaneous voltage between collector and emitter terminals when the emitter current is reduced to zero by means of a reverse emitter base voltage, i.e. the base voltage is normally positive with respect to emitter for PNP transistor and negative with respect to emitter for NPN types.

NOTE: The term "cut-off" is sometimes replaced by $V_{BE} > x$ volts, or $\frac{R_B}{R_E} \leq y$ which are equivalent conditions under which the device may be cut-off.

$V_{CEmax} (I_C = x \text{ mA})$ The maximum permissible instantaneous voltage between collector and emitter terminals when the collector current is at a high value, often the max. rated value.

$V_{CEmax} (I_B = 0)$ The maximum permissible instantaneous voltage between collector and emitter terminals when the base terminal is open circuited or when a very high resistance is in series with the base terminal. Special care must be taken to ensure that thermal runaway due to excessive collector leakage current does not occur in this condition.

Due to the current dependency of V_{CE} it is usual to present this information as a voltage rating chart which is a curve of collector current versus collector to emitter voltage (see Fig. 1).

TRANSISTOR RATINGS

This curve is divided into two areas:

A permissible area of operation under all conditions of base drive provided the dissipation rating is not exceeded (area 1) and an area where operation is allowable under certain specified conditions (area 2). To assist in determining the rating in this second area, further curves are provided relating the voltage rating to external circuit conditions, for example:

$$\frac{R_B}{R_E}, R_B, Z_{Bg}, V_{BE}, I_B \text{ or } \frac{V_{BB}}{R_B}.$$

An example of this type of curve is given in Fig. 2 as V_{CE} versus $\frac{R_B}{R_E}$ for two different values of collector current.

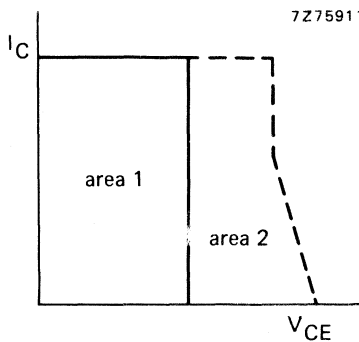

Fig. 1.

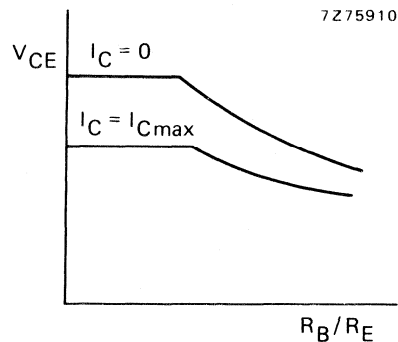

Fig. 2.

It should be noted that when R_E is shunted by a capacitor, the collector voltage V_{CE} during switching must be restricted to a value which does not rely on the effect of R_E .

In the case of an inductive load and when an energy rating is given, it may be permissible to operate outside the rated area provided the specified energy rating is not exceeded.

Transistor current ratings

Collector current ratings

- I_{Cmax} The maximum permissible collector current. Without further qualification, the d.c. value is implied.
- $I_{C(AV)max}$ The maximum permissible average value of the total collector current
- I_{CM} The maximum permissible instantaneous value of the total collector current.

Emitter current ratings

- I_{Emax} The maximum permissible emitter current. Without further qualification, the d.c. value is implied.
- $I_{E(AV)max}$ The maximum permissible average value of the total emitter current.
- $I_{ER(AV)max}$ The maximum permissible average value of the total emitter current when operating in the reverse emitter-base breakdown region.
- I_{EM} The maximum permissible instantaneous value of the total emitter current.
- I_{ERM} The maximum permissible instantaneous value of the total reverse emitter current allowable in the reverse breakdown region.

Base current ratings

I_{Bmax}	The maximum permissible base current. Without further qualification, the d.c. value is implied.
$I_{B(AV)max}$	The maximum permissible average value of the total base current.
$I_{BR(AV)max}$	The maximum permissible average value of the total reverse base current allowable in the reverse breakdown region.
I_{BM}	The maximum permissible instantaneous value of the total base current. The rating also includes the switch off current.
I_{BRM}	The maximum permissible instantaneous value of the total reverse current allowable in the reverse breakdown region.

Transistor power ratings

P_{tot} max: The total maximum permissible continuous power dissipation in the transistor and includes both the collector-base dissipation and the emitter-base dissipation. Under steady state conditions the total power is given by the expression:

$$P_{tot} = V_{CE} \times I_C + V_{BE} \times I_B.$$

In order to distinguish between "steady state" and "pulse" conditions the terms "steady state power (P_S)" and "pulse power (P_P)" are often used. The permissible total power dissipation is dependent upon temperature and its relationship is shown by means of a chart as shown in Fig. 3.

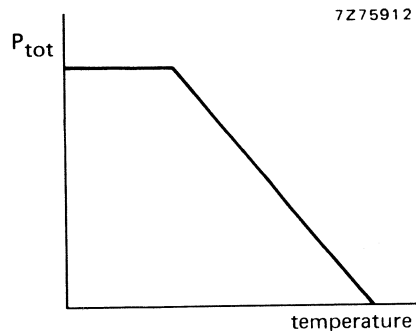

Fig. 3.

The temperature may be ambient, case or mounting base temperatures. Where a cooling clip or a heatsink is attached to the device, the allowable power dissipation is also dependent on the efficiency of the heatsink.

The efficiency of this clip or heatsink is measured in terms of its thermal resistance ($R_{th h}$) normally expressed in degrees kelvin per watt (K/W). For mounting base rated devices, the added effect of the contact resistance ($R_{th i}$) must be taken into account.

The effect of heatsinks of various thermal resistance and contact resistance is often included in the above chart.

Thus for any heatsink of known thermal resistance and any given ambient temperature, the maximum permissible power dissipation can be established. Alternatively, knowing the power dissipation which will occur and the ambient temperature, the necessary heatsink thermal resistance can be calculated.

A general expression from which the total permissible steady state power dissipation can be calculated is:

$$P_{tot} = \frac{T_j - T_{amb}}{R_{th\ j-a}}$$

where $R_{th\ j-a}$ is the thermal resistance from the transistor junction to the ambient. For case rated or mounting base rated devices, the thermal resistance $R_{th\ j-a}$ is made up of the thermal resistance junction to case or mounting base ($R_{th\ j-mb}$), the contact thermal resistance ($R_{th\ i}$) and the heatsink thermal resistance $R_{th\ h}$.

For the calculation of pulse power operation P_p , the maximum pulse power is obtained by the aid of a chart as shown in Fig. 4.

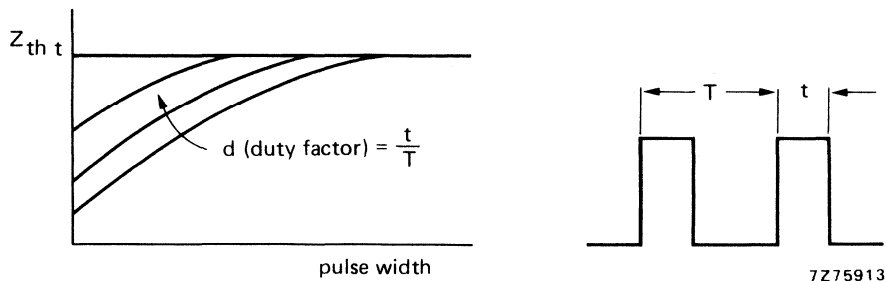

Fig. 4.

The general expression from which the maximum pulse power dissipation can be calculated is:

$$P_p = \frac{T_j - T_{amb} - P_s \times R_{th\ j-a}}{Z_{th\ t} + d (R_{th\ c-a})}$$

where $Z_{th\ t}$ and d are given in the above chart and $R_{th\ c-a}$ is the thermal resistance between case and ambient for case rated device. For mounting base rated device, it is equal to $R_{th\ h} + R_{th\ i}$ and is zero for free air rated device because the effect of the temperature rise of the case over the ambient for a pulse train is already included in $Z_{th\ t}$.

Temperature ratings

T_{jmax}	The maximum permissible junction temperature which is used as the basis for the calculation of power ratings. Unless otherwise stated, the continuous value is implied.
T_{jmax} (continuous operation)	The maximum permissible continuous value.
T_{jmax} (intermittent operation)	The maximum permissible instantaneous junction temperature usually allowed for a total duration of 200 hours.
T_{mb}	The temperature of the surface making contact with a heatsink. This is confined to devices where a flange or stud for fixing onto a heatsink forms an integral part of the envelope.
T_{case}	The temperature of the envelope. This is confined to devices to which may be attached a clip-on cooling fin.

LETTER SYMBOLS FOR TRANSISTORS AND SIGNAL DIODES

based on IEC Publication 148

LETTER SYMBOLS FOR CURRENTS, VOLTAGES AND POWERS

Basic letters

The basic letters to be used are:

I, i = current
 V, v = voltage
 P, p = power.

Lower-case basic letters shall be used for the representation of instantaneous values which vary with time.

In all other instances upper-case basic letters shall be used.

Subscripts

A, a	Anode terminal
(AV), (av)	Average value
B, b	Base terminal, for MOS devices; Substrate
(BR)	Breakdown
C, c	Collector terminal
D, d	Drain terminal
E, e	Emitter terminal
F, f	Forward
G, g	Gate terminal
K, k	Cathode terminal
M, m	Peak value
O, o	As third subscript: The terminal not mentioned is open circuited
R, r	As first subscript: Reverse. As second subscript: Repetitive. As third subscript: With a specified resistance between the terminal not mentioned and the reference terminal.
(RMS), (rms)	R. M. S. value
S, s	{ As first or second subscript: Source terminal (for FETS only) As second subscript: Non-repetitive (not for FETS) As third subscript: Short circuit between the terminal not mentioned and the reference terminal
X, x	Specified circuit
Z, z	Replaces R to indicate the actual working voltage, current or power of voltage reference and voltage regulator diodes.

Note: No additional subscript is used for d. c. values.

Upper-case subscripts shall be used for the indication of:

- a) continuous (d. c.) values (without signal)
Example I_B
- b) instantaneous total values
Example i_B
- c) average total values
Example $I_{B(AV)}$
- d) peak total values
Example I_{BM}
- e) root-mean-square total values
Example $I_{B(RMS)}$

Lower-case subscripts shall be used for the indication of values applying to the varying component alone :

- a) instantaneous values
Example i_b
- b) root-mean-square values
Example $I_{b(rms)}$
- c) peak values
Example I_{bm}
- d) average values
Example $I_{b(av)}$

Note: If more than one subscript is used, subscript for which both styles exist shall either be all upper-case or all lower-case.

Additional rules for subscripts

Subscripts for currents

Transistors: If it is necessary to indicate the terminal carrying the current, this should be done by the first subscript (conventional current flow from the external circuit into the terminal is positive).

Examples: I_B , i_B , i_b , I_{bm}

Diodes: To indicate a forward current (conventional current flow into the anode terminal) the subscript F or f should be used; for a reverse current (conventional current flow out of the anode terminal) the subscript R or r should be used.

Examples: I_F , I_R , i_F , $I_{f(rms)}$

Subscripts for voltages

Transistors: If it is necessary to indicate the points between which a voltage is measured, this should be done by the first two subscripts. The first subscript indicates the terminal at which the voltage is measured and the second the reference terminal or the circuit node. Where there is no possibility of confusion, the second subscript may be omitted.

Examples: V_{BE} , v_{BE} , v_{be} , V_{bem}

Diodes: To indicate a forward voltage (anode positive with respect to cathode), the subscript F or f should be used; for a reverse voltage (anode negative with respect to cathode) the subscript R or r should be used.

Examples: V_F , V_R , v_F , V_{rm}

Subscripts for supply voltages or supply currents

Supply voltages or supply currents shall be indicated by repeating the appropriate terminal subscript.

Examples: V_{CC} , I_{EE}

Note: If it is necessary to indicate a reference terminal, this should be done by a third subscript

Example: V_{CCE}

Subscripts for devices having more than one terminal of the same kind

If a device has more than one terminal of the same kind, the subscript is formed by the appropriate letter for the terminal followed by a number; in the case of multiple subscripts, hyphens may be necessary to avoid misunderstanding.

Examples: I_{B2} = continuous (d.c.) current flowing into the second base terminal

V_{B2-E} = continuous (d.c.) voltage between the terminals of second base and emitter

Subscripts for multiple devices

For multiple unit devices, the subscripts are modified by a number preceding the letter subscript; in the case of multiple subscripts, hyphens may be necessary to avoid misunderstanding.

Examples: I_{2C} = continuous (d.c.) current flowing into the collector terminal of the second unit

V_{1C-2C} = continuous (d.c.) voltage between the collector terminals of the first and the second unit.

Application of the rules

The figure below represents a transistor collector current as a function of time. It consists of a continuous (d. c.) current and a varying component.

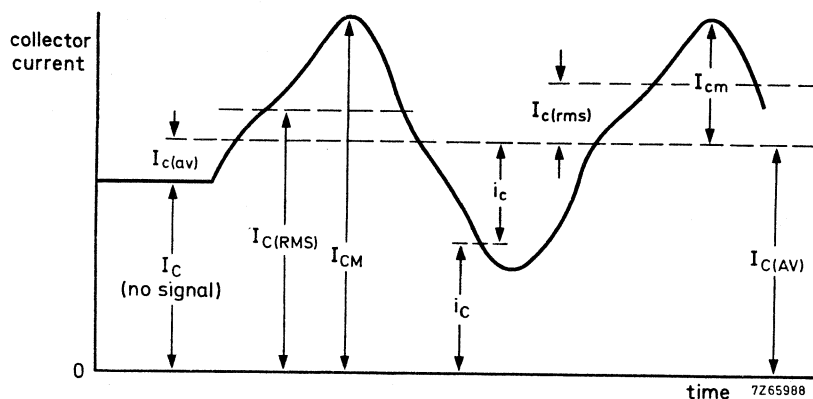

LETTER SYMBOLS FOR ELECTRICAL PARAMETER METER

Defenition

For the purpose of this Publication, the term "electrical parameter" applies to four-pole matrix parameters, elements of electrical equivalent circuits, electrical impedances and admittances, inductances and capacitances.

Basic letters

The following is a list of the most important basic letters used for electrical parameters of semiconductor devices.

- B, b = susceptance; imaginary part of an admittance
- C = capacitance
- G, g = conductance; real part of an admittance
- H, h = hybrid parameter
- L = inductance
- R, r = resistance; real part of an impedance
- X, x = reactance; imaginary part of an impedance
- Y, y = admittance;
- Z, z = impedance;

Upper-case letters shall be used for the representation of:

- a) electrical parameters of external circuits and of circuits in which the device forms only a part;
- b) all inductances and capacitances.

Lower-case letters shall be used for the representation of electrical parameters inherent in the device (with the exception of inductances and capacitances).

Subscripts

General subscripts

The following is a list of the most important general subscripts used for electrical parameters of semiconductor devices:

F, f	= forward; forward transfer
l, i (or 1)	= input
L, l	= load
O, o (or 2)	= output
R, r	= reverse; reverse transfer
S, s	= source

Examples: Z_S , h_f , h_F

The upper-case variant of a subscript shall be used for the designation of static (d.c.) values.

Examples : h_{FE} = static value of forward current transfer ratio in common-emitter configuration (d.c. current gain)

R_E = d.c. value of the external emitter resistance.

Note: The static value is the slope of the line from the origin to the operating point on the appropriate characteristic curve, i.e. the quotient of the appropriate electrical quantities at the operating point.

The lower-case variant of a subscript shall be used for the designation of small-signal values.

Examples: h_{fe} = small-signal value of the short-circuit forward current transfer ratio in common-emitter configuration

Z_e = $R_e + jX_e$ = small-signal value of the external impedance

Note: If more than one subscript is used, subscripts for which both styles exist shall either be all upper-case or all lower-case

Examples: h_{FE} , y_{RE} , h_{fe}

Subscripts for four-pole matrix parameters

The first letter subscript (or double numeric subscript) indicates input, output, forward transfer or reverse transfer

Examples: h_i (or h_{11})
 h_o (or h_{22})
 h_f (or h_{21})
 h_r (or h_{12})

A further subscript is used for the identification of the circuit configuration. When no confusion is possible, this further subscript may be omitted.

Examples: h_{fe} (or h_{21e}), h_{FE} (or h_{21E})

Distinction between real and imaginary parts

If it is necessary to distinguish between real and imaginary parts of electrical parameters, no additional subscripts should be used. If basic symbols for the real and imaginary parts exist, these may be used.

Examples: $Z_i = R_i + jX_i$
 $y_{fe} = g_{fe} + jb_{fe}$

If such symbols do not exist or if they are not suitable, the following notation shall be used:

Examples: $\text{Re}(h_{ib})$ etc. for the real part of h_{ib}
 $\text{Im}(h_{ib})$ etc. for the imaginary part of h_{ib}

SCATTERING PARAMETERS

In distinction to the conventional h , y and z -parameters, s -parameters relate to travelling wave conditions. The figure below shows a two-port network with the incident and reflected waves a_1 , b_1 , a_2 and b_2 .

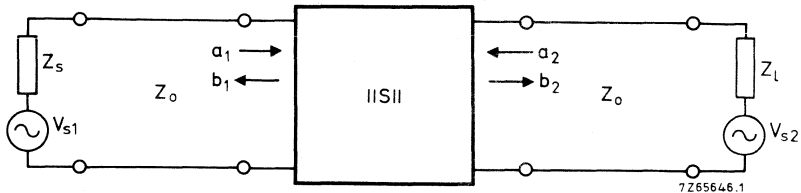

$$a_1 = \frac{V_{i1}}{\sqrt{Z_0}}$$

$$a_2 = \frac{V_{i2}}{\sqrt{Z_0}}$$

1)

$$b_1 = \frac{V_{r1}}{\sqrt{Z_0}}$$

$$b_2 = \frac{V_{r2}}{\sqrt{Z_0}}$$

Z_0 = characteristic impedance of the transmission line in which the two-port is connected.

V_i = incident voltage

V_r = reflected (generated) voltage

The four-pole equations for s -parameters are:

$$b_1 = s_{11}a_1 + s_{12}a_2$$

$$b_2 = s_{21}a_1 + s_{22}a_2$$

Using the subscripts i for 11, r for 12, f for 21 and o for 22, it follows that:

$$s_i = s_{11} = \left. \frac{b_1}{a_1} \right|_{a_2 = 0}$$

$$s_r = s_{12} = \left. \frac{b_1}{a_2} \right|_{a_1 = 0}$$

$$s_f = s_{21} = \left. \frac{b_2}{a_1} \right|_{a_2 = 0}$$

$$s_o = s_{22} = \left. \frac{b_2}{a_2} \right|_{a_1 = 0}$$

1) The squares of these quantities have the dimension of power.

S-PARAMETERS

The s-parameters can be named and expressed as follows:

$s_i = s_{11}$ = Input reflection coefficient.

The complex ratio of the reflected wave and the incident wave at the input, under the conditions $Z_1 = Z_0 = 50 \Omega$ and $V_{s2} = 0$.

$s_r = s_{12}$ = Reverse transmission coefficient.

The complex ratio of the generated wave at the input and the incident wave at the output, under the conditions $Z_s = Z_0 = 50 \Omega$ and $V_{s1} = 0$.

$s_f = s_{21}$ = Forward transmission coefficient.

The complex ratio of the generated wave at the output and the incident wave at the input, under the conditions $Z_1 = Z_0 = 50 \Omega$ and $V_{s2} = 0$.

$s_o = s_{22}$ = Output reflection coefficient.

The complex ratio of the reflected wave and the incident wave at the output, under the conditions $Z_s = Z_0 = 50 \Omega$ and $V_{s1} = 0$.

DEVICE DATA

DEVELOPMENT DATA

This data sheet contains advance information and specifications are subject to change without notice.

BA682
BA683

BAND-SWITCHING DIODES FOR SURFACE MOUNTING

Switching diodes in a SOD-80 envelope, intended for band switching in v.h.f. television tuners. A special feature of these diodes is their low capacitance.

These SM diodes are leadless diodes in an hermetically sealed micro-miniature glass envelope with tin-plated metal discs at each end. They are suitable for Automatic Placement and as such they can withstand immersion soldering.

The diodes are delivered in "super 8" tape.

QUICK REFERENCE DATA

		BA682	BA683	
Continuous reverse voltage	V_R max.	35	35	V
Forward current (d.c.)	I_F max.	100	100	mA
Junction temperature	T_j max.	150	150	°C
Diode capacitance $V_R = 3\text{ V}; f = 1\text{ MHz}$	$C_d <$	1,25	1,2	pF
Series resistance at $f = 200\text{ MHz}$				
$I_F = 3\text{ mA}$	$r_D <$	0,7	1,2	Ω
$I_F = 10\text{ mA}$	$r_D <$	0,5	0,9	Ω

MECHANICAL DATA

Dimensions in mm

Fig. 1 SOD-80.

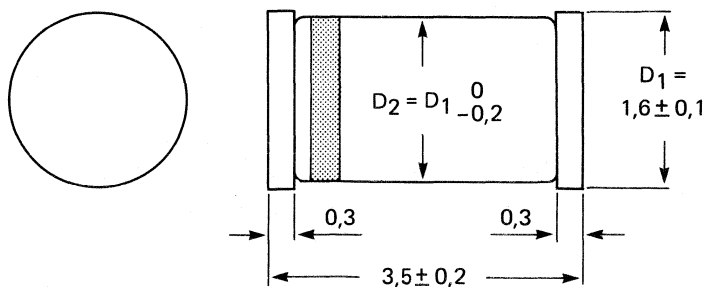

7Z91084.1

The cathode is indicated by a red band.

The BA683 cathode has an additional orange band.

RATINGS

Limiting values in accordance with the Absolute Maximum System (IEC 134)

Continuous reverse voltage	V_R max.	35	V
Forward current (d.c.)	I_F max.	100	mA
Storage temperature	T_{stg}	-65 to +150	°C
Junction temperature	T_j	150	°C

THERMAL RESISTANCE

From junction to ambient in free air	$R_{th\ j-a}$	0,6	K/mW
--------------------------------------	---------------	-----	------

CHARACTERISTICS

$T_j = 25$ °C unless otherwise specified.

Forward voltage

$I_F = 100$ mA

V_F	<	1,0	V
-------	---	-----	---

Reverse current

$V_R = 20$ V

$V_R = 20$ V; $T_{amb} = 75$ °C

I_R	<	50	nA
	<	1	μA

		BA682	BA683	
--	--	--------------	--------------	--

Diode capacitance at $f = 1$ MHz

$V_R = 1$ V

$V_R = 3$ V

C_d	<	1,5	1,5	pF
	<	1,25	1,2	pF

Series resistance at $f = 200$ MHz

$I_F = 3$ mA

$I_F = 10$ mA

r_D	<	0,7	1,2	Ω
	<	0,5	0,9	Ω

SILICON PLANAR EPITAXIAL HIGH-SPEED DIODE

Silicon epitaxial high-speed diode in a microminiature plastic envelope. It is intended for high-speed switching in hybrid thick and thin-film circuits.

QUICK REFERENCE DATA

Continuous reverse voltage	V_R	max.	75 V
Repetitive peak reverse voltage	V_{RRM}	max.	85 V
Repetitive peak forward current	I_{FRM}	max.	250 mA
Junction temperature	T_j	max.	175 °C
Forward voltage at $I_F = 50$ mA	V_F	<	1,0 V
Reverse recovery time when switched from $I_F = 10$ mA to $I_R = 10$ mA; $R_L = 100 \Omega$; measured at $I_R = 1$ mA	t_{rr}	<	6 ns
Recovery charge when switched from $I_F = 10$ mA to $V_R = 5$ V; $R_L = 500 \Omega$	Q_s	<	45 pC

MECHANICAL DATA

Dimensions in mm

Marking code

Fig. 1 SOT-23.

BAS16 = A6

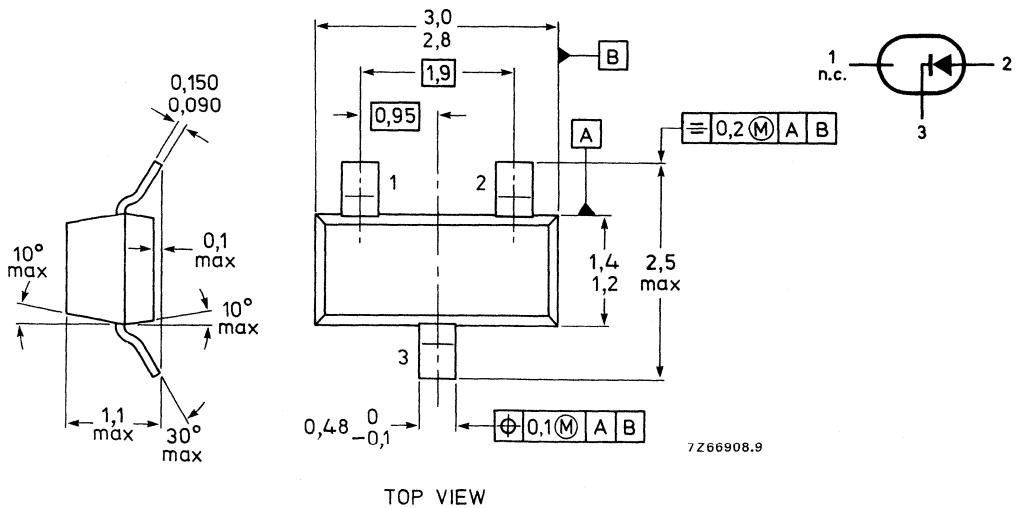

See also *Soldering recommendations*.

RATINGS

Limiting values in accordance with the Absolute Maximum System (IEC 134)

Continuous reverse voltage	V_R	max.	75 V
Repetitive peak reverse voltage	V_{RRM}	max.	85 V
Average rectified forward current [▲] (averaged over any 20 ms period) up to $T_{amb} = 25\text{ }^\circ\text{C}^{**}$	$I_{F(AV)}$	max.	250 mA
Forward current (d.c.)	I_F	max.	250 mA
Repetitive peak forward current	I_{FRM}	max.	250 mA
→ Non-repetitive peak forward current (per crystal)	I_{FSM}	max.	2 A
$t = 1\text{ }\mu\text{s}$	I_{FSM}	max.	1 A
$t = 1\text{ ms}$	I_{FSM}	max.	0,5 A
$t = 1\text{ s}$	I_{FSM}	max.	0,5 A
Storage temperature range	T_{stg}		-65 to +175 $^\circ\text{C}$
Junction temperature	T_j	max.	175 $^\circ\text{C}$
THERMAL RESISTANCE*			
→ From junction to ambient**	R_{thj-a}	=	430 K/W

CHARACTERISTICS

$T_j = 25\text{ }^\circ\text{C}$ unless otherwise specified.

Forward voltage	V_F	<	715 mV
$I_F = 1\text{ mA}$	V_F	<	855 mV
$I_F = 10\text{ mA}$	V_F	<	1000 mV
$I_F = 50\text{ mA}$	V_F	<	1250 mV
$I_F = 150\text{ mA}$	V_F	<	1250 mV
Reverse current	I_R	<	30 μA
$V_R = 25\text{ V}; T_j = 150\text{ }^\circ\text{C}$	I_R	<	1 μA
$V_R = 75\text{ V}$	I_R	<	50 μA
$V_R = 75\text{ V}; T_j = 150\text{ }^\circ\text{C}$	I_R	<	50 μA
Diode capacitance	C_d	<	2 pF
$V_R = 0; f = 1\text{ MHz}$	C_d	<	2 pF
Forward recovery voltage (see also Fig. 2) when switched to $I_F = 10\text{ mA}; t_p = 20\text{ ns}$	V_{fr}	<	1,75 V
Reverse recovery time (see also Fig. 3) when switched from $I_F = 10\text{ mA}$ to $I_R = 10\text{ mA};$ $R_L = 100\text{ }\Omega$; measured at $I_R = 1\text{ mA}$	t_{rr}	<	6 ns
Recovery charge (see also Fig. 4) when switched from $I_F = 10\text{ mA}$ to $V_R = 5\text{ V};$ $R_L = 500\text{ }\Omega$	Q_s	<	45 pC

▲ Measured under pulse conditions. $t_p \leq 0,5\text{ ms}$. $I_{F(AV)} = 150\text{ mA}$, $t_{(av)} \leq 1\text{ ms}$, for sinusoidal operation.

* See *Thermal characteristics*.

** Mounted on a ceramic substrate of 8 mm x 10 mm x 0,7 mm.

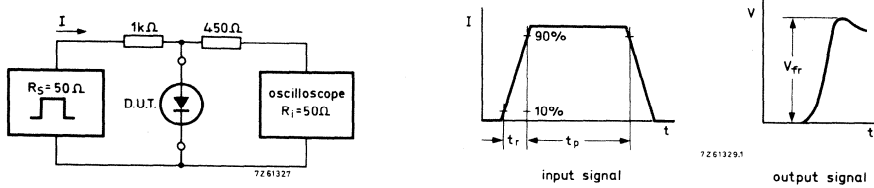

Fig. 2 Forward recovery voltage test circuit and waveforms.

Input signal: forward pulse rise time = $t_r = 20$ ns; forward current pulse duration $t_p = 120$ ns; duty factor = $\delta = 0,01$.
 Oscilloscope: rise time = $t_r = 0,35$ ns.
 Circuit capacitance $C \leq 1$ pF ($C =$ oscilloscope input capacitance + parasitic capacitance).

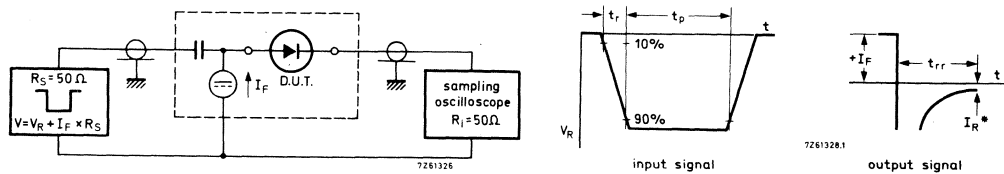

Fig. 3 Reverse recovery time test circuit and waveforms.

Input signal: reverse pulse rise time = $t_r = 0,6$ ns; reverse pulse duration = $t_p = 100$ ns; duty factor = $\delta = 0,05$. * t_{rr} up to $I_R = 1$ mA.
 Oscilloscope: rise time = $t_r = 0,35$ ns.
 Circuit capacitance $C \leq 1$ pF ($C =$ oscilloscope input capacitance + parasitic capacitance).

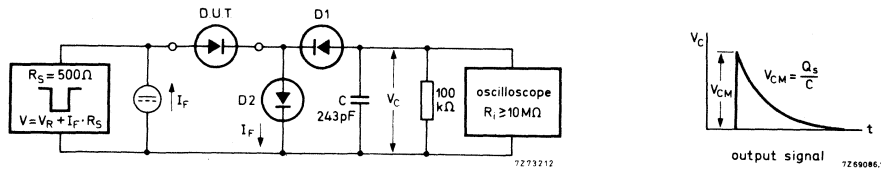

Fig. 4 Recovery charge test circuit and waveform.

D1 = BAW62; D2 = diode with minority carrier life time at 10 mA: < 200 ps

Input signal

Rise time of the reverse pulse	t_r	=	2 ns
Reverse pulse duration	t_p	=	400 ns
Duty factor	δ	=	0,02

Circuit capacitance $C \leq 7$ pF ($C =$ oscilloscope input capacitance + parasitic capacitance).

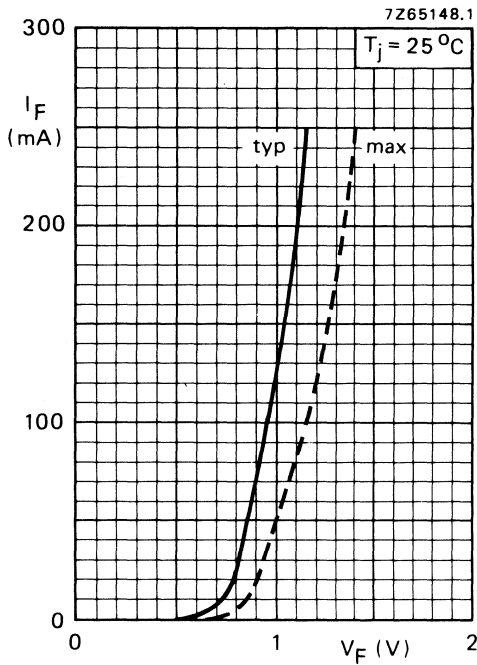

Fig. 5.

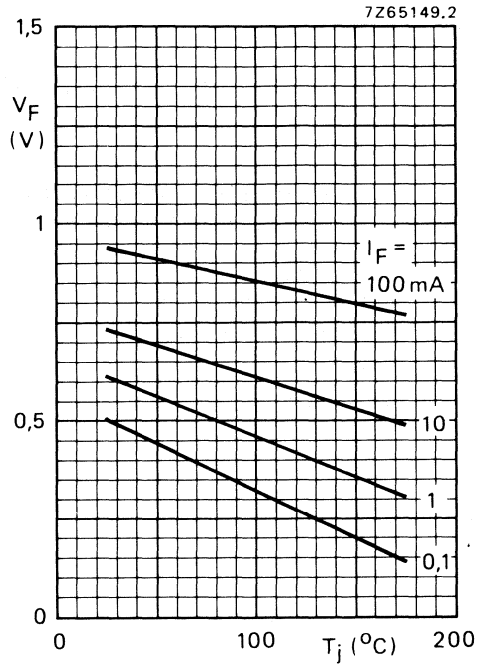

Fig. 6 Typical values.

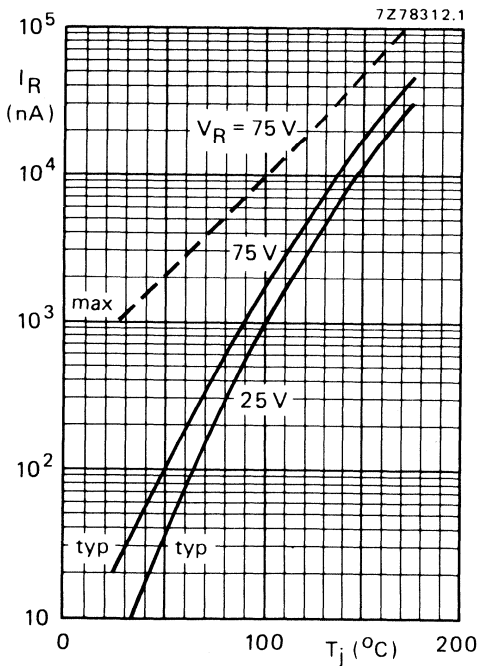

Fig. 7.

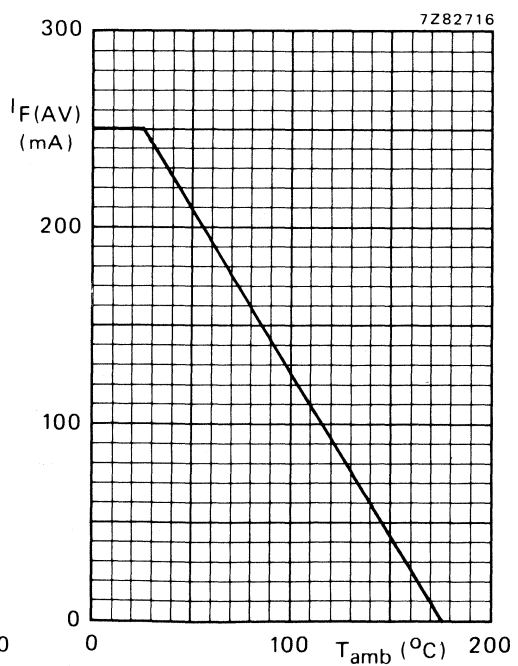

Fig. 8 Current derating curve.

LOW VOLTAGE STABISTOR

Silicon planar epitaxial diode in SOT-23 envelope. This diode is intended for low voltage stabilizing e.g. bias stabilizer in class-B output stages, clipping, clamping and meter protection.

QUICK REFERENCE DATA

Repetitive peak forward current	I_{FRM}	max.	250 mA
Storage temperature	T_{stg}	-65 to + 150 °C	
Junction temperature	T_j	max.	175 °C
Forward voltage			
$I_F = 0,1$ mA	V_F		580 to 660 mV
$I_F = 1,0$ mA	V_F		665 to 745 mV
$I_F = 10$ mA	V_F		750 to 830 mV
$I_F = 100$ mA	V_F		870 to 960 mV
Diode capacitance			
$V_R = 0$; $f = 1$ MHz	C_d	<	140 pF

MECHANICAL DATA

Dimensions in mm

Fig. 1 SOT-23.

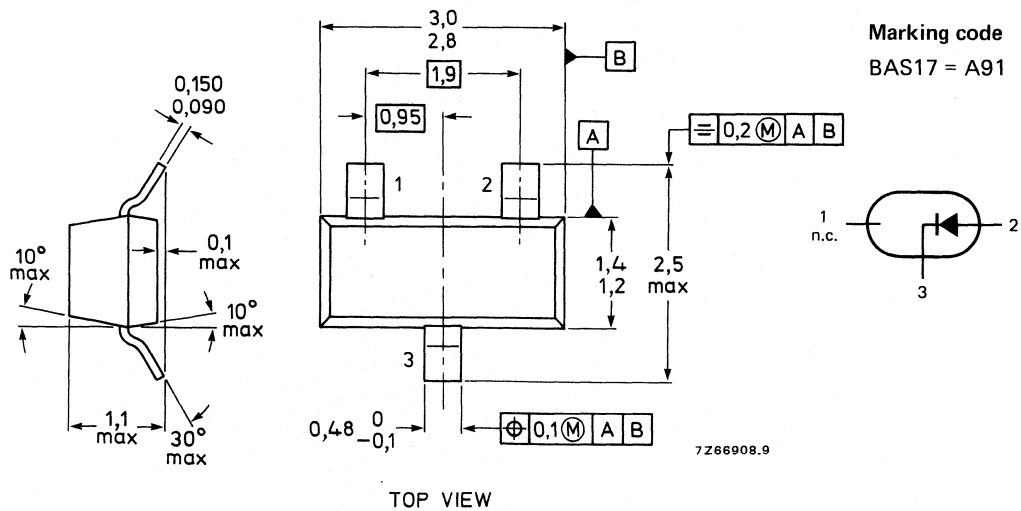

See also chapter *Soldering Recommendations*.

RATINGS

Limiting values in accordance with the Absolute Maximum System (IEC 134)

Repetitive peak forward current **	I_{FRM}	max.	250 mA
Storage temperature	T_{stg}	-65 to + 150	°C
Junction temperature	T_j	max.	175 °C

THERMAL CHARACTERISTICS*

$$T_j = P_x (R_{th\ j-t} + R_{th\ t-s} + R_{th\ s-a}) + T_{amb}$$

Thermal resistance

From junction to tab	$R_{th\ j-t}$	=	60 K/W
From tab to soldering points	$R_{th\ t-s}$	=	280 K/W
From soldering points to ambient**	$R_{th\ s-a}$	=	90 K/W

CHARACTERISTICS

$T_j = 25\text{ °C}$ unless otherwise specified

Forward voltage

$I_F = 0,1\text{ mA}$	V_F	580 to 660 mV
$I_F = 1,0\text{ mA}$	V_F	665 to 745 mV
$I_F = 5,0\text{ mA}$	V_F	725 to 805 mV
$I_F = 10\text{ mA}$	V_F	750 to 830 mV
$I_F = 100\text{ mA}$	V_F	870 to 960 mV

Reverse current

$V_R = 4\text{ V}$	I_R	<	5 μA
--------------------	-------	---	-----------------

Temperature coefficient

$I_F = 1\text{ mA}$	S_F	typ.	-1,8 mV/K
---------------------	-------	------	-----------

Diode capacitance

$V_R = 0; f = 1\text{ MHz}$	C_d	<	140 pF
-----------------------------	-------	---	--------

* See *Thermal characteristics*.

** Mounted on a ceramic substrate of 7 mm x 5 mm x 0,5 mm.

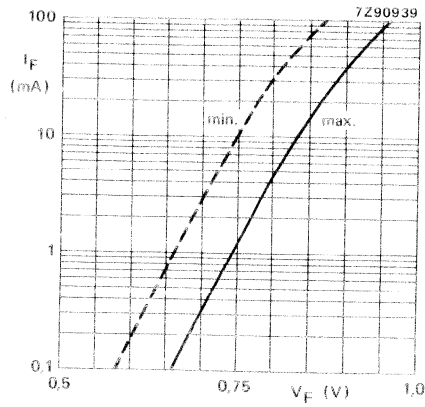

Fig. 2 Forward current as a function of forward voltage.

SILICON PLANAR EPITAXIAL HIGH-SPEED DIODES

Silicon epitaxial high-speed diodes in a microminiature plastic envelope. They are intended for switching and general purposes.

QUICK REFERENCE DATA

		BAS19	BAS20	BAS21	
Continuous reverse voltage	V_R max.	100	150	200	V
Repetitive peak reverse voltage	V_{RRM} max.	120	200	250	V
Repetitive peak forward current	I_{FRM} max.		625		mA
Junction temperature	T_j max.		150		°C
Forward voltage at $I_F = 100$ mA	$V_F <$		1		V
Reverse recovery time when switched from $I_F = 30$ mA to $I_R = 30$ mA; $R_L = 100 \Omega$ measured at $I_R = 3$ mA	$t_{rr} <$		50		ns

MECHANICAL DATA

Fig. 1 SOT-23.

Dimensions in mm

Marking code

BAS19 = A8
BAS20 = A81
BAS21 = A82

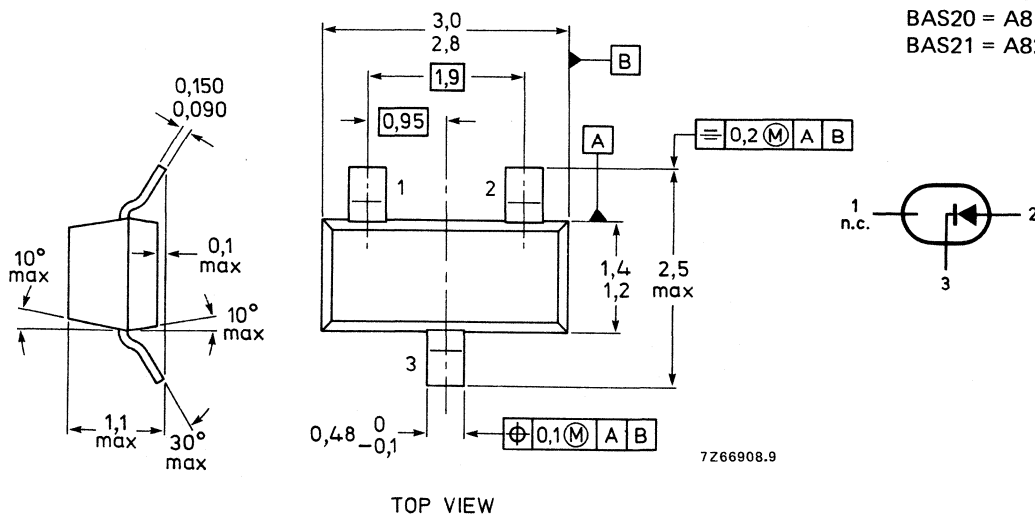

See also *Soldering recommendations*.

RATINGS

Limiting values in accordance with the Absolute Maximum System (IEC 134)

		BAS19	BAS20	BAS21
Continuous reverse voltage	V_R	max. 100	150	200 V
Repetitive peak reverse voltage	V_{RRM}	max. 120	200	250 V
→ Non-repetitive peak forward current (per crystal)				
$t = 1 \mu s$	I_{FSM}	max.	2,5	A
$t = 1 s$	I_{FSM}	max.	0,5	A
Average rectified forward current (1) (averaged over any 20 ms period)	$I_{F(AV)}$	max.	200	mA
Forward current (d.c.) up to $T_{amb} = 25 \text{ }^\circ\text{C}^{**}$	I_F	max.	200	mA
Repetitive peak forward current	I_{FRM}	max.	625	mA
Storage temperature range	T_{stg}		-65 to + 150	$^\circ\text{C}$
Junction temperature	T_j	max.	150	$^\circ\text{C}$
Total power dissipation up to $T_{amb} = 25 \text{ }^\circ\text{C}$	P_{tot}	max.	200	mW

THERMAL RESISTANCE*

From junction to ambient**	$R_{thj a}$	=	430 K/W
From tab to soldering points	$R_{th t s}$	=	280 K/W
From soldering points to ambient**	$R_{th s a}$	=	90 K/W

CHARACTERISTICS

$T_j = 25 \text{ }^\circ\text{C}$ unless otherwise specified.

Forward voltage

$I_F = 100 \text{ mA}$	V_F	<	1,0 V
$I_F = 200 \text{ mA}$	V_F	<	1,25 V

Reverse breakdown voltage (1)

BAS19; $I_R = 100 \mu\text{A}$	$V_{(BR)R}$	>	120 V
BAS20; $I_R = 100 \mu\text{A}$	$V_{(BR)R}$	>	200 V
BAS21; $I_R = 100 \mu\text{A}$ (2)	$V_{(BR)R}$	>	250 V

Reverse current

$V_R = V_{Rmax}$	I_R	<	100 nA
$V_R = V_{Rmax}; T_j = 150 \text{ }^\circ\text{C}$	I_R	<	100 μA

Differential resistance

$I_F = 10 \text{ mA}$	r_{diff}	typ.	5 Ω
-----------------------	------------	------	------------

(1) Measured under pulse conditions; Pulse time = $t_p \leq 0,3 \text{ ms}$.

(2) At zero life time, measured under pulse conditions to avoid excessive dissipation and voltage limited to 275 V.

* See *Thermal characteristics*.

** Mounted on a ceramic substrate of 8 mm x 10 mm x 0,7 mm.

Diode capacitance

$V_R = 0$; $f = 1 \text{ MHz}$

$C_d < 5 \text{ pF}$

Reverse recovery time (see Figs 2 and 3)

when switched from $I_F = 30 \text{ mA}$ to $I_R = 30 \text{ mA}$;

$R_L = 100 \Omega$; measured at $I_R = 3 \text{ mA}$

$t_{rr} < 50 \text{ ns}$

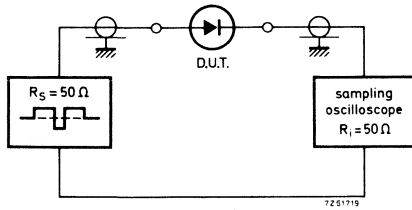

Fig. 2 Test circuit.

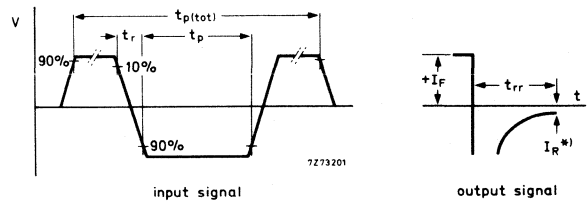

Fig. 3 Waveforms; $I_R = 3 \text{ mA}$.

Input signal

total pulse duration

$t_{p(\text{tot})} = 2 \mu\text{s}$

duty factor

$\delta = 0,0025$

rise time of reverse pulse

$t_r = 0,6 \text{ ns}$

reverse pulse duration

$t_p = 100 \text{ ns}$

Oscilloscope

rise time

$t_r = 0,35 \text{ ns}$

circuit capacitance*

$C < 1 \text{ pF}$

*C = oscilloscope input capacitance + parasitic capacitance.

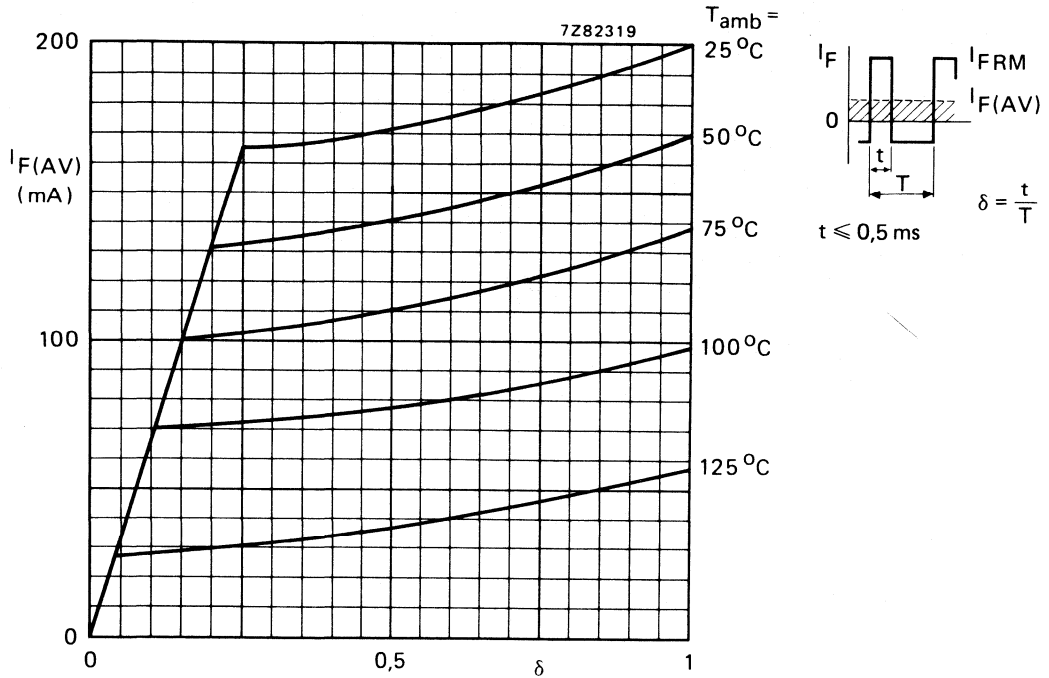

Fig. 4 BAS19; maximum permissible average rectified forward current for pulse operation as a function of the duty factor at $V_R = 100 \text{ V}$.

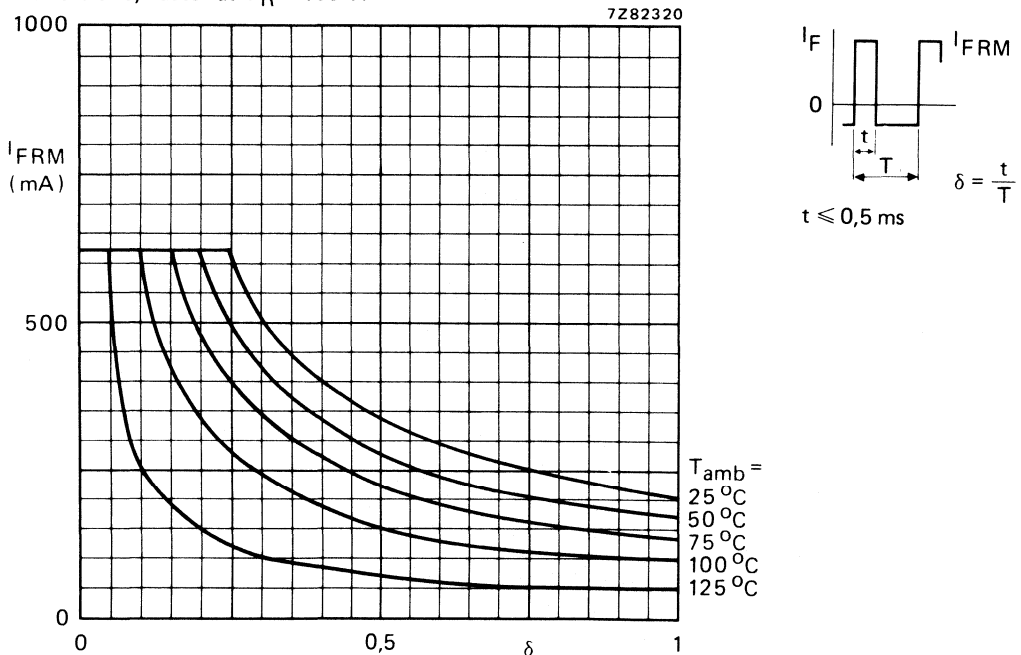

Fig. 5 BAS19; maximum permissible repetitive peak forward current for pulse operation as a function of the duty factor at $V_R = 100 \text{ V}$.

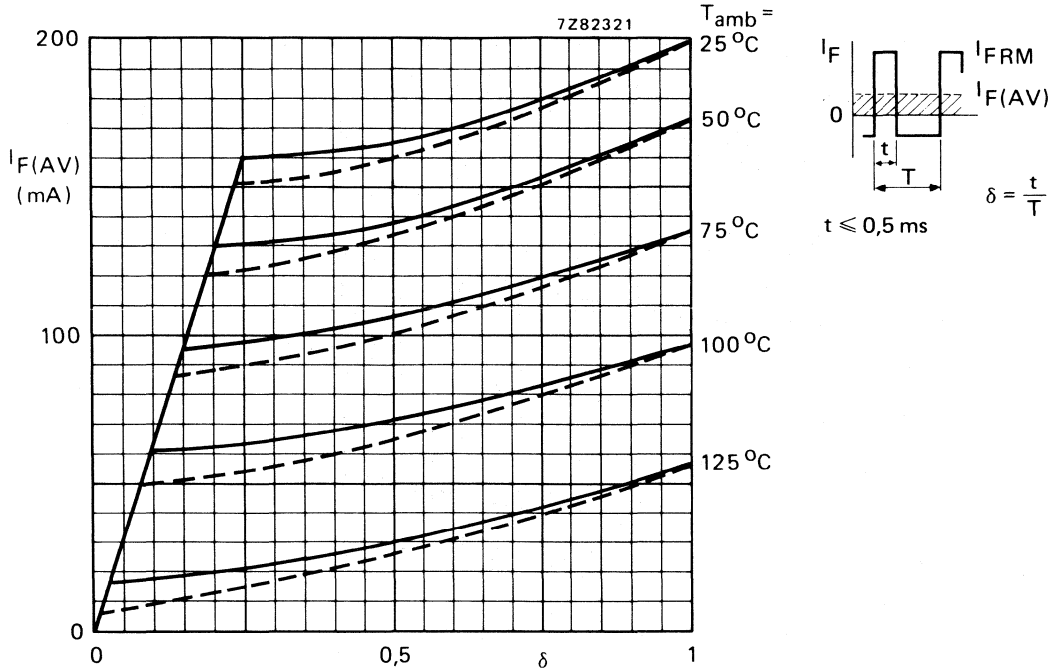

Fig. 6 BAS20/21; maximum permissible average rectified forward current for pulse operation as a function of the duty factor.

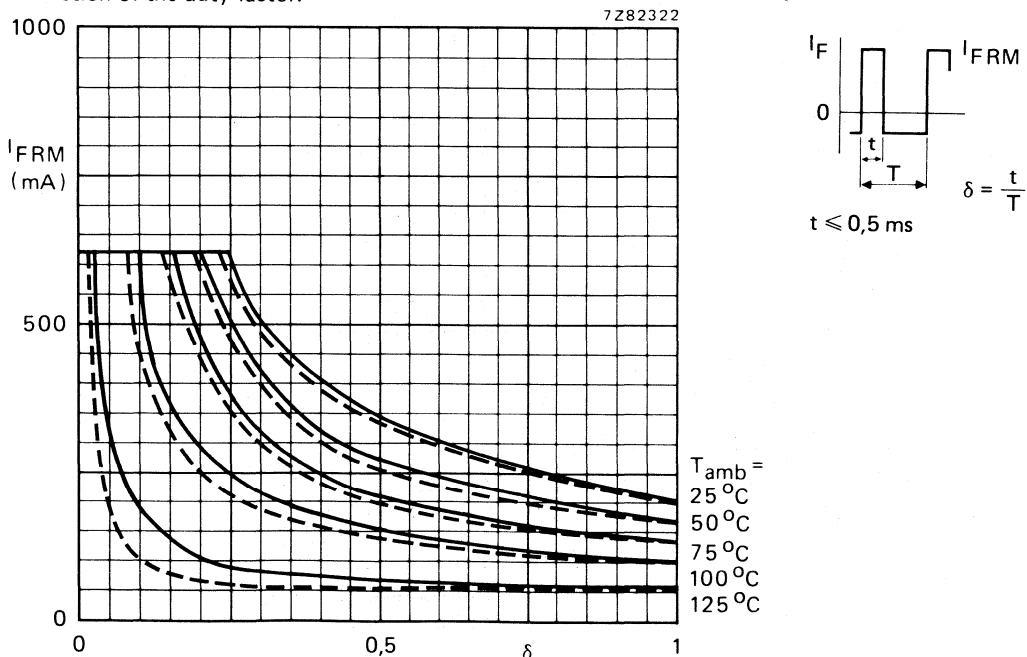

Fig. 7 BAS20/21; maximum permissible repetitive peak forward current for pulse operation as a function of the duty factor.

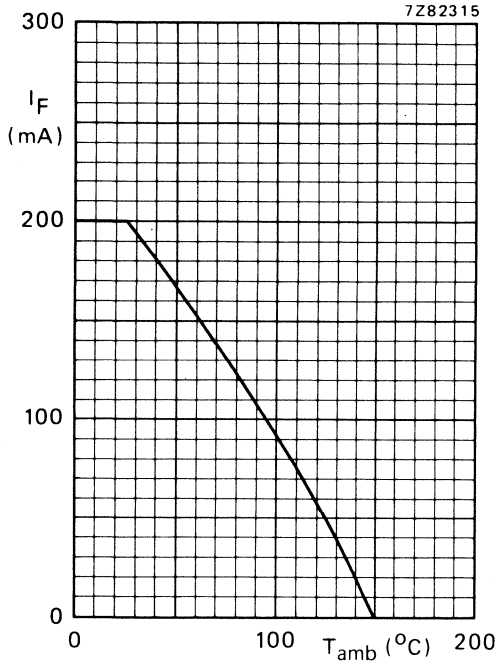

Fig. 8.

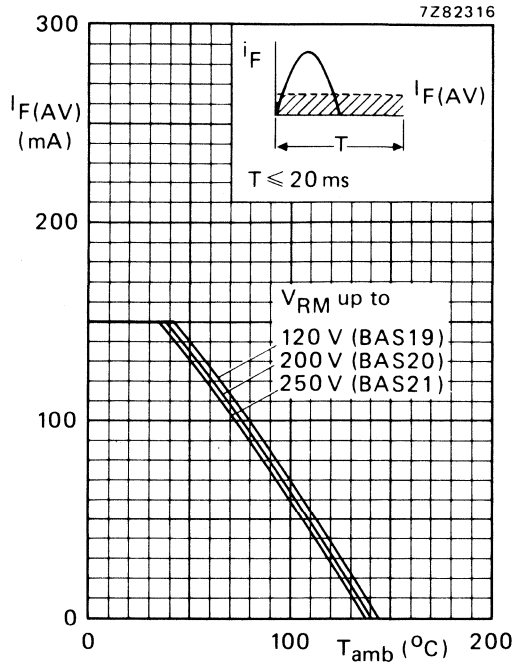

Fig. 9.

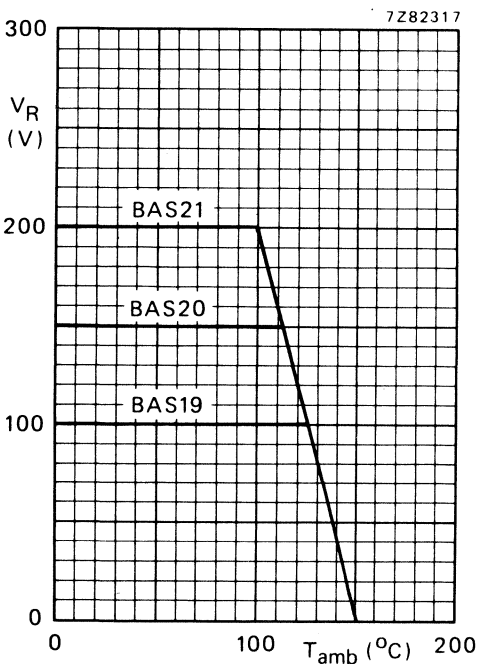

Fig. 10.

Fig. 8 Maximum permissible continuous forward current as a function of the ambient temperature.

Fig. 9 Maximum permissible average rectified forward current as a function of the ambient temperature.

Fig. 10 Maximum permissible continuous reverse voltage as a function of the ambient temperature.

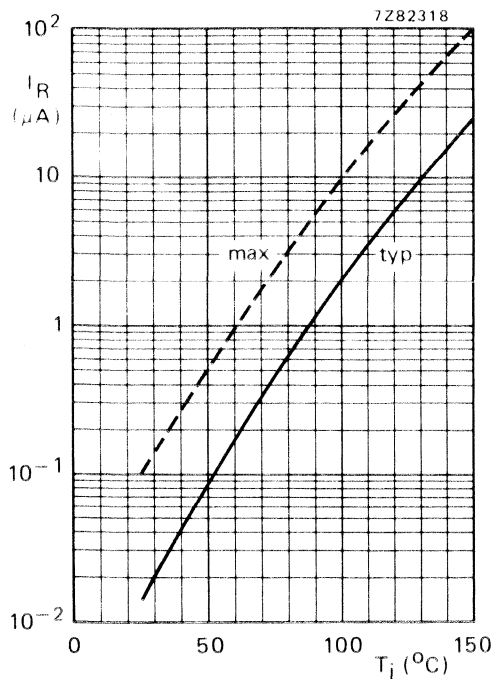

Fig. 11.

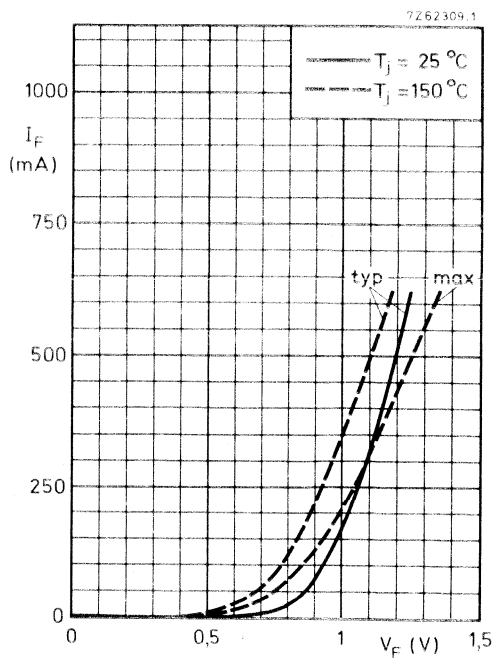

Fig. 12.

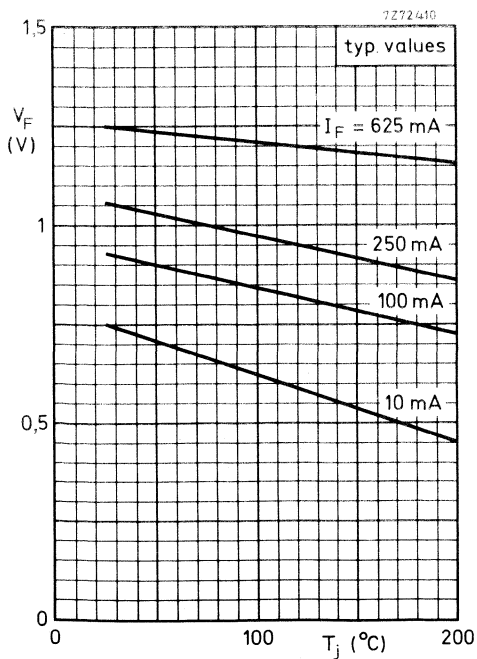

Fig. 13.

Fig. 11 Continuous reverse current as a function of the junction temperature.

Fig. 12 Forward current as a function of forward voltage.

Fig. 13 Forward voltage as a function of the junction temperature.

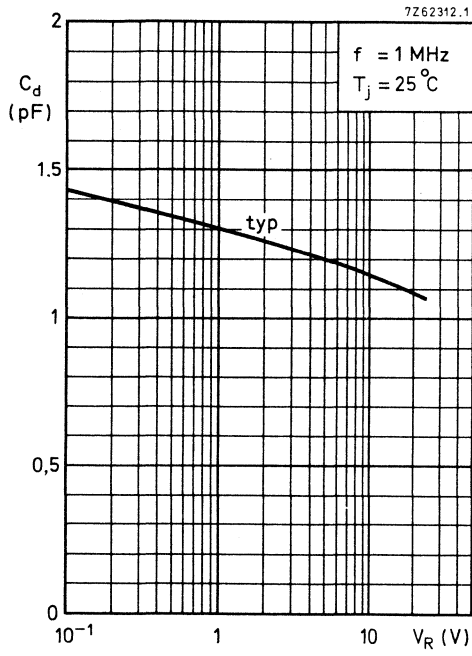

Fig. 14.

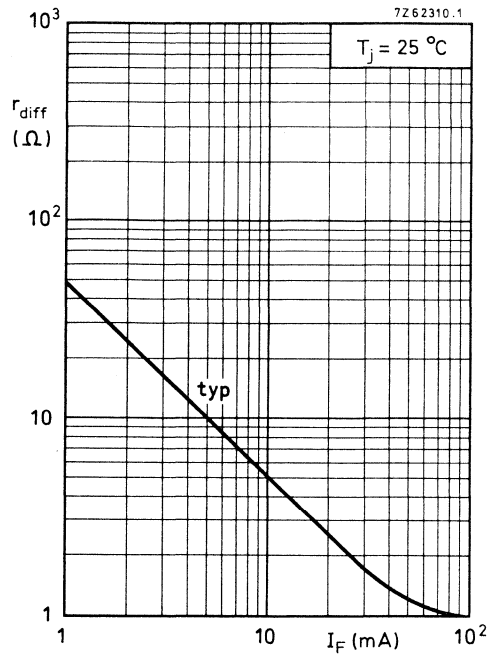

Fig. 15.

SILICON PLANAR EPITAXIAL HIGH-SPEED DIODE

The BAS28 consists of two separate diodes in one microminiature envelope intended for surface mounting.

It concerns fast-switching general-purpose diodes.

QUICK REFERENCE DATA

Continuous reverse voltage	V_R	max.	75 V
Repetitive peak reverse voltage	V_{RRM}	max.	85 V
Repetitive peak forward current	I_{FRM}	max.	250 mA
Junction temperature	T_j	max.	175 °C
Forward voltage at $I_F = 50$ mA	V_F	<	1,0 V
Reverse recovery time when switched from $I_F = 10$ mA to $I_R = 10$ mA; $R_L = 100 \Omega$, measured at $I_R = 1$ mA	t_{rr}		6 ns
Recovery charge when switched from $I_F = 10$ mA to $V_R = 5$ V; $R_L = 500 \Omega$	Q_s	<	45 pC

MECHANICAL DATA

Fig. 1 SOT-143.

Dimensions in mm

Marking code. A61

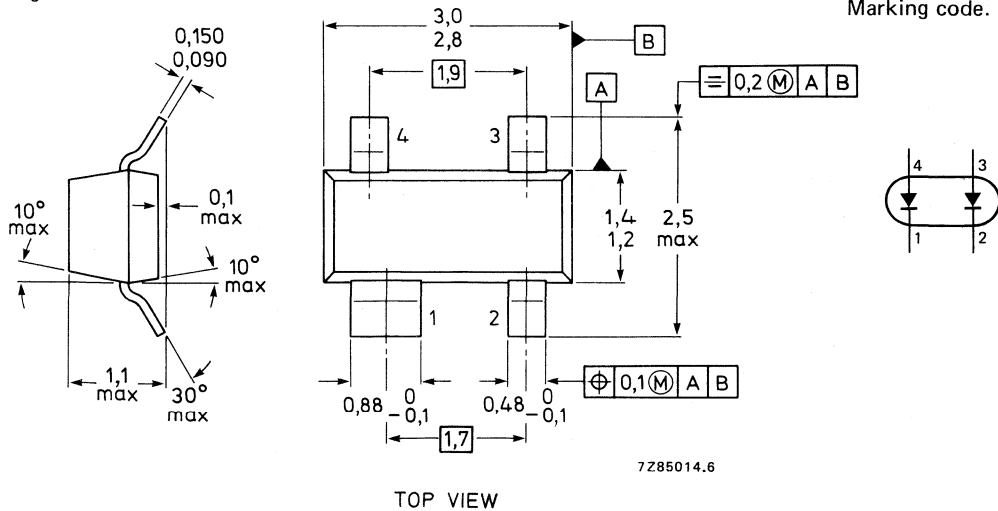

RATINGS

Limiting values in accordance with the Absolute Maximum System (IEC 134)

Continuous reverse voltage	V_R	max.	75 V
Repetitive peak reverse voltage	V_{RRM}	max.	85 V
Average rectified forward current [▲] (averaged over any 20 ms period) up to $T_{amb} = 25\text{ °C}^{**}$	$I_{F(AV)}$	max.	250 mA
Forward current (d.c.)	I_F	max.	250 mA
Repetitive peak forward current	I_{FRM}	max.	250 mA
→ Non-repetitive peak forward current (per crystal) $t = 1\ \mu\text{s}$ $t = 1\ \text{ms}$ $t = 1\ \text{s}$	I_{FSM}	max.	2 A
	I_{FSM}	max.	1 A
	I_{FSM}	max.	0,5 A
Storage temperature range	T_{stg}		-65 to + 175 °C
Junction temperature	T_j	max.	175 °C

THERMAL RESISTANCE*

From junction to ambient	$R_{th\ j-a}$	=	430 K/W
--------------------------	---------------	---	---------

CHARACTERISTICS

$T_j = 25\text{ °C}$ unless otherwise specified

Forward voltage

$I_F = 1\ \text{mA}$	V_F	<	715 mV
$I_F = 10\ \text{mA}$	V_F	<	855 mV
$I_F = 50\ \text{mA}$	V_F	<	1000 mV
$I_F = 150\ \text{mA}$	V_F	<	1250 mV

Reverse current

$V_R = 25\ \text{V}; T_j = 150\text{ °C}$	I_R	<	30 μA
$V_R = 75\ \text{V}$	I_R	<	1 μA
$V_R = 75\ \text{V}; T_j = 150\text{ °C}$	I_R	<	50 μA

Diode capacitance

$V_R = 0; f = 1\ \text{MHz}$	C_d	<	2 pF
------------------------------	-------	---	------

Forward recovery voltage (see also Fig. 2)

when switched to $I_F = 10\ \text{mA}; t_p = 20\ \text{ns}$	V_{fr}	<	1,75 V
---	----------	---	--------

Reverse recovery time (see also Fig. 3)

when switched from $I_F = 10\ \text{mA}$ to $I_R = 10\ \text{mA};$ $R_L = 100\ \Omega;$ measured at $I_R = 1\ \text{mA}$	t_{rr}	<	6 ns
---	----------	---	------

Recovery charge (see also Fig. 4)

when switched from $I_F = 10\ \text{mA}$ to $V_R = 5\ \text{V};$ $R_L = 500\ \Omega$	Q_s	<	45 pC
---	-------	---	-------

▲ Measured under pulse conditions. $t_p \leq 0,5\ \text{ms}$. $I_{F(AV)} = 150\ \text{mA}$, $t_{(av)} \leq 1\ \text{ms}$, for sinusoidal operation.

* See *Thermal characteristics*.

** Mounted on a ceramic substrate of 8 mm x 10 mm x 0,7 mm.

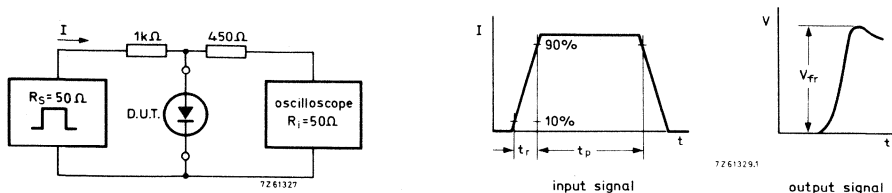

Fig. 2 Forward recovery voltage test circuit and waveforms.

Input signal: forward pulse rise time = $t_r = 20$ ns; forward current pulse duration $t_p = 120$ ns; duty factor = $\delta = 0,01$.

Oscilloscope: rise time = $t_r = 0,35$ ns.

Circuit capacitance $C \leq 1$ pF ($C =$ oscilloscope input capacitance + parasitic capacitance).

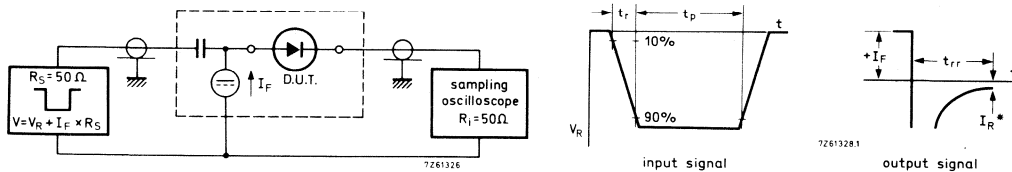

Fig. 3 Reverse recovery time test circuit and waveforms.

Input signal: reverse pulse rise time = $t_r = 0,6$ ns; reverse pulse duration = $t_p = 100$ ns; duty factor = $\delta = 0,05$.
* t_{rr} up to $I_R = 1$ mA.

Oscilloscope: rise time = $t_r = 0,35$ ns.

Circuit capacitance $C \leq 1$ pF ($C =$ oscilloscope input capacitance + parasitic capacitance).

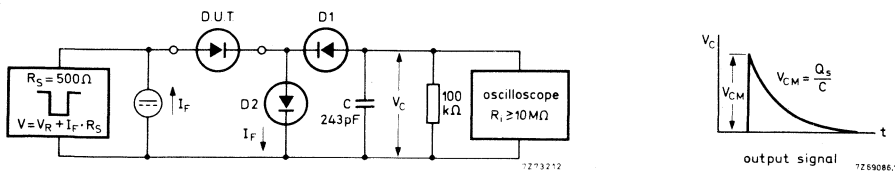

Fig. 4 Recovery charge test circuit and waveform.

D1 = BAW62; D2 = diode with minority carrier life time at 10 mA: < 200 ps

Input signal

Rise time of the reverse pulse

Reverse pulse duration

Duty factor

$$\begin{aligned} t_r &= 2 \text{ ns} \\ t_p &= 400 \text{ ns} \\ \delta &= 0,02 \end{aligned}$$

Circuit capacitance $C \leq 7$ pF ($C =$ oscilloscope input capacitance + parasitic capacitance).

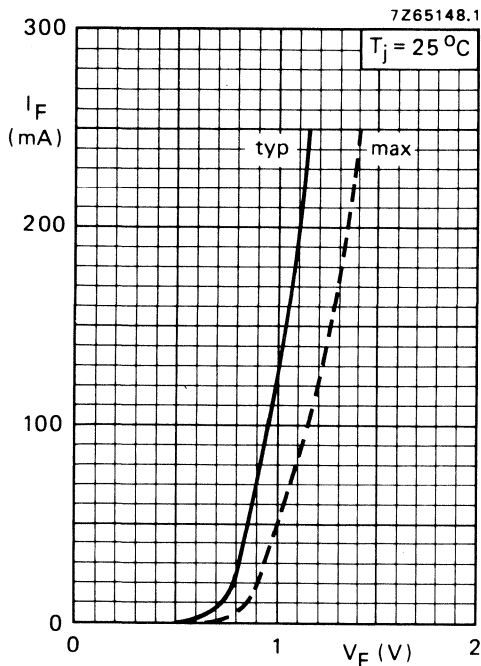

Fig. 5.

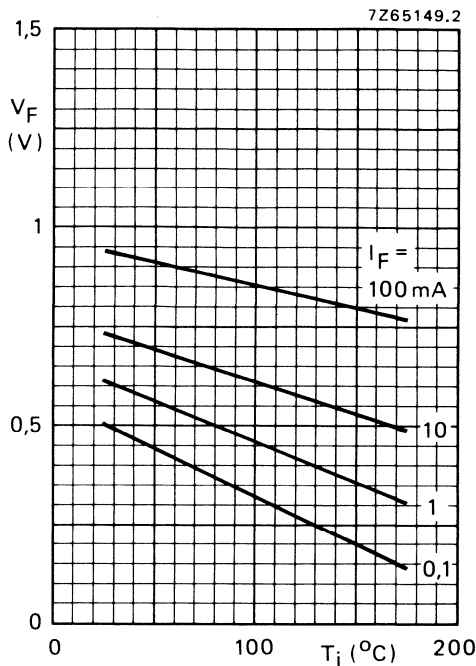

Fig. 6 Typical values.

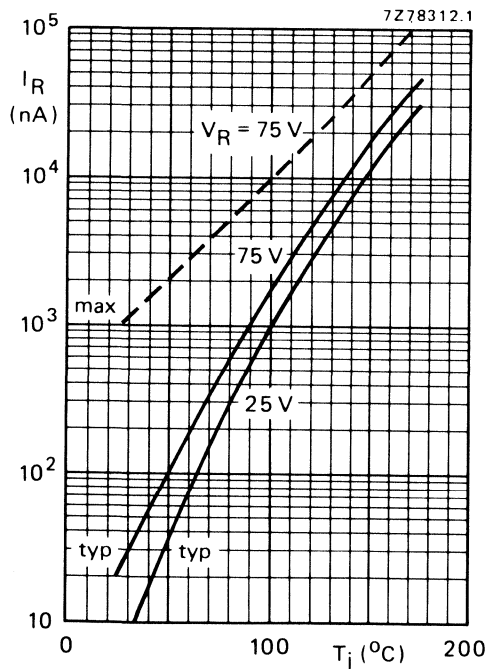

Fig. 7.

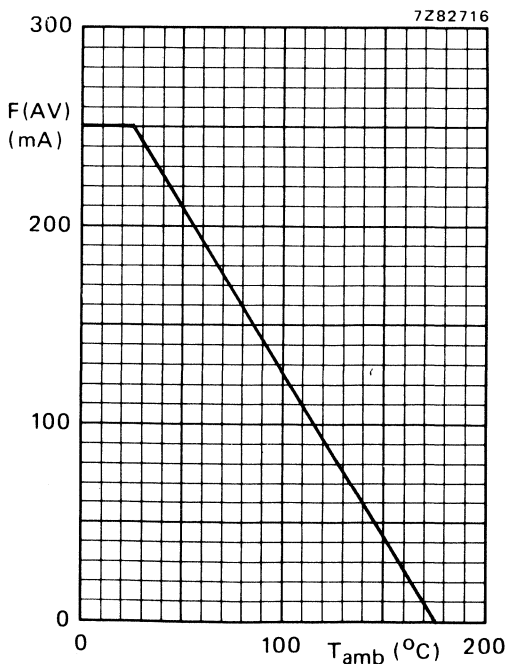

Fig. 8 Current derating curve.

SILICON PLANAR EPITAXIAL HIGH-SPEED DIODES

The BAS29, BAS31 and the BAS35 are silicon planar epitaxial diodes encapsulated in a SOT-23 envelope. The BAS29 consists of a single diode. The BAS31 has two diodes in series and the BAS35 has two diodes with a common anode. All diodes are designed for switching inductive loads in semi-electronic telephone exchanges.

QUICK REFERENCE DATA (per diode)

Continuous reverse voltage	V_R	max.	90 V
Repetitive peak forward current	I_{FRM}	max.	600 mA
Forward current	I_F	max.	250 mA
Junction temperature	T_j	max.	150 °C
Forward voltage at $I_F = 50$ mA	V_F	<	0,84 V
Reverse recovery time when switched from $I_F = 30$ mA to $I_R = 30$ mA; $R_L = 100 \Omega$; measured at $I_R = 3$ mA	t_{rr}	<	50 ns

MECHANICAL DATA

Fig. 1 SOT-23.

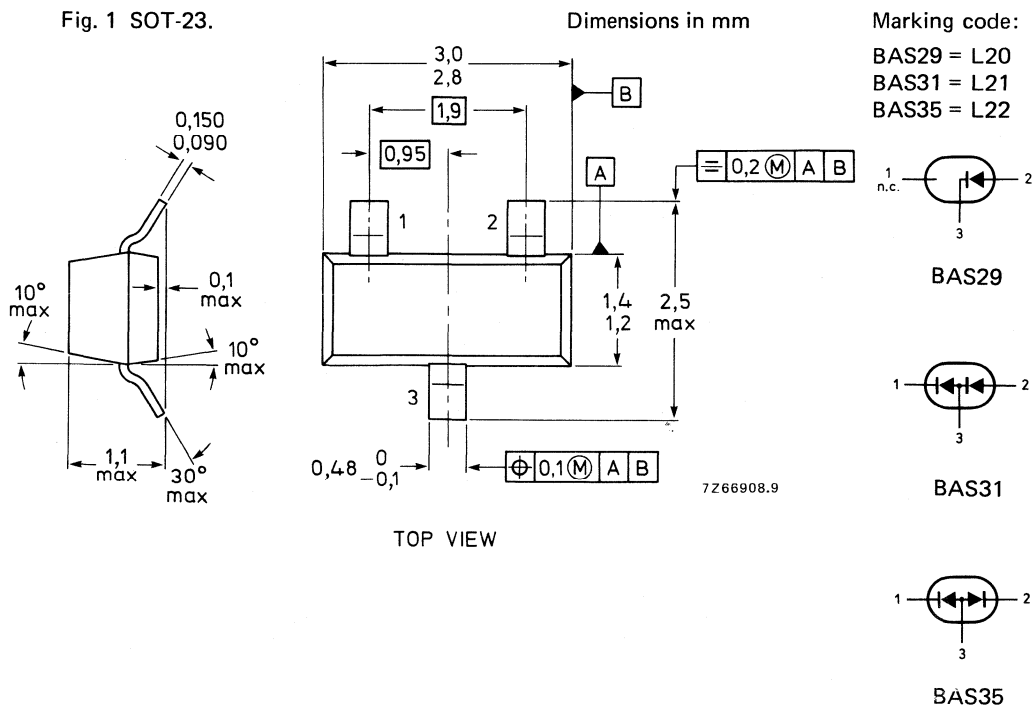

RATINGS (per diode)

Limiting values in accordance with the Absolute Maximum System (IEC 134)

Continuous reverse voltage	V_R	max.	90 V
Repetitive peak forward current	I_{FRM}	max.	600 mA
Repetitive peak reverse current	I_{RRM}	max.	600 mA
Average rectified forward current (averaged over any 20 ms period)	I_F	max.	250 mA
Non-repetitive peak forward current $t = 1 \mu s; T_j = 25 \text{ }^\circ\text{C}$ prior to surge; per crystal $t = 1 \text{ s}; T_j = 25 \text{ }^\circ\text{C}$ prior to surge; per crystal	I_{FSM}	max.	3 A 0,75 A
Forward current (d.c.)	I_F	max.	250 mA
Repetitive peak reverse energy $t_p \leq 50 \text{ s}; f \leq 20 \text{ Hz}; T_j = 25 \text{ }^\circ\text{C}$	E_{RRM}	\leq	5,0 mJ
Storage temperature	T_{stg}		-65 to +175 $^\circ\text{C}$
Junction temperature	T_j	max.	150 $^\circ\text{C}$

THERMAL RESISTANCE

From junction to ambient when mounted on ceramic substrate of 7 mm x 5 mm x 0,5 mm

$$R_{th \text{ j-a}} = 430 \text{ K/W}$$

CHARACTERISTICS (per diode)

$T_j = 25 \text{ }^\circ\text{C}$ unless otherwise specified

Forward voltage

$I_F = 10 \text{ mA}$	V_F	\leq	0,75 V
$I_F = 50 \text{ mA}$	V_F	\leq	0,84 V
$I_F = 100 \text{ mA}$	V_F	\leq	0,90 V
$I_F = 200 \text{ mA}$	V_F	\leq	1,00 V
$I_F = 400 \text{ mA}$	V_F	\leq	1,25 V

Reverse current

$V_R = 90 \text{ V}$	I_R	\leq	100 nA
$V_R = 90 \text{ V}; T_j = 150 \text{ }^\circ\text{C}$	I_R	\leq	100 μA

Reverse avalanche breakdown voltage

$I_R = 1 \text{ mA}$	$V_{(BR)R}$		120 to 175 V
----------------------	-------------	--	--------------

Diode capacitance

$V_R = 0; f = 1 \text{ MHz}$	C_d	\leq	35 pF
------------------------------	-------	--------	-------

Reverse recovery time when switched from

$I_F = 30 \text{ mA}$ to $I_R = 30 \text{ mA}; R_L = 100 \Omega$; measured at $I_R = 3 \text{ mA}$	t_{rr}	\leq	50 ns
--	----------	--------	-------

HIGH-SPEED SILICON DIODE FOR SURFACE MOUNTING

The BAS32 is a planar epitaxial high-speed diode designed for fast logic applications.

This SM diode is a leadless diode in a hermetically sealed SOD-80 envelope with tin-plated metal discs at each end. It is suitable for "automatic placement" and as such it can withstand immersion soldering.

The diodes are delivered in "super 8" tape.

QUICK REFERENCE DATA

Continuous reverse voltage	V_R	max.	75 V
Repetitive peak reverse voltage	V_{RRM}	max.	75 V
Repetitive peak forward current	I_{FRM}	max.	450 mA
Junction temperature	T_j	max.	200 °C
Forward voltage $I_F = 100 \text{ mA}$	V_F	<	1 V
Reverse recovery time when switched from $I_F = 10 \text{ mA}$ to $I_R = 10 \text{ mA}$; $R_L = 100 \Omega$; measured at $I_R = 1 \text{ mA}$	t_{rr}	<	4 ns

MECHANICAL DATA

Dimensions in mm

Fig. 1 SOD-80.

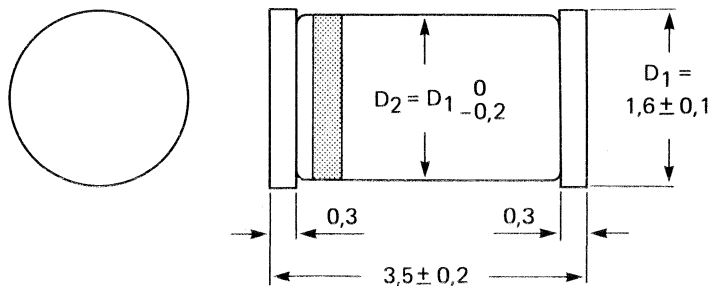

7Z91084.1

Cathode indicated by black band.

RATINGS

Limiting values in accordance with the Absolute Maximum System (IEC 134)

Continuous reverse voltage	V_R	max.	75 V
Repetitive peak reverse voltage	V_{RRM}	max.	75 V*
Average rectified forward current	$I_{F(AV)}$	max.	150 mA**
Forward current (d.c.)	I_F	max.	200 mA
Repetitive peak forward current	I_{FRM}	max.	450 mA
Non-repetitive peak forward current			
$t = 1 \mu s$	I_{FSM}	max.	2000 mA
$t = 1 s$	I_{FSM}	max.	500 mA
Storage temperature	T_{stg}		-65 to +200 °C
Junction temperature	T_j	max.	200 °C

THERMAL RESISTANCE

From junction to ambient in free air	$R_{th j-a}$	=	0,6 K/mW
--------------------------------------	--------------	---	----------

CHARACTERISTICS

$T_j = 25 \text{ °C}$ unless otherwise specified

Forward voltages

$I_F = 5 \text{ mA}$	V_F	0,62 to 0,75 V
$I_F = 100 \text{ mA}$	V_F	< 1,00 V
$I_F = 100 \text{ mA}; T_j = 100 \text{ °C}$	V_F	< 0,93 V

Reverse currents

$V_R = 20 \text{ V}$	I_R	< 25 nA
$V_R = 20 \text{ V}; T_j = 150 \text{ °C}$	I_R	< 50 μA
$V_R = 75 \text{ V}$	I_R	< 5 μA
$V_R = 75 \text{ V}; T_j = 150 \text{ °C}$	I_R	< 100 μA

Diode capacitance

$V_R = 0; f = 1 \text{ MHz}$	C_d	< 2 pF
------------------------------	-------	--------

Forward recovery voltage when switched to

$I_F = 50 \text{ mA}; t_r = 20 \text{ ns}$	V_{fr}	< 2,5 V
--	----------	---------

* Measured at zero life time at $I_R = 100 \mu A; V_R > 100 \text{ V}$.

** For sinusoidal operation see Fig. 6. For pulse operation see Figs 4 and 5.

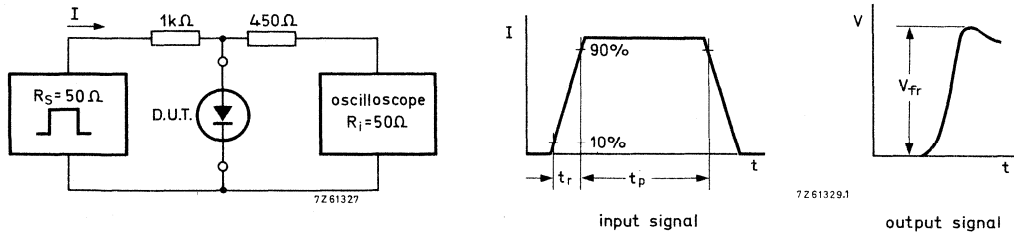

Fig. 2 Forward recovery voltage test circuit and waveforms.

Input signal : Rise time of the forward pulse $t_r = 20 \text{ ns}$
 Forward current pulse duration $t_p = 120 \text{ ns}$
 Duty factor $\delta = 0,01$

Oscilloscope: Rise time $t_r = 0,35 \text{ ns}$

Circuit capacitance $C \leq 1 \text{ pF}$ ($C = \text{oscilloscope input capacitance} + \text{parasitic capacitance}$)

Reverse recovery time when switched from
 $I_F = 10 \text{ mA}$ to $I_R = 10 \text{ mA}$; $R_L = 100 \Omega$;
 measured at $I_R = 1 \text{ mA}$

$$t_{rr} < 4 \text{ ns}$$

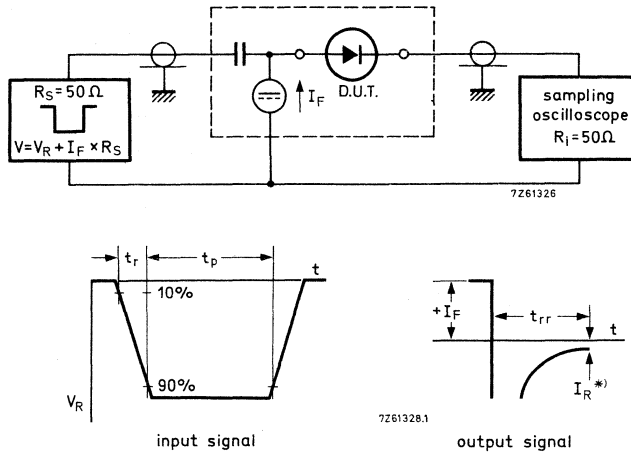

Fig. 3 Reverse recovery time test circuit and waveforms.

Input signal : Rise time of the reverse pulse $t_r = 0,6 \text{ ns}$ * $I_R = 1 \text{ mA}$
 Reverse pulse duration $t_p = 100 \text{ ns}$
 Duty factor $\delta = 0,05$

Oscilloscope: Rise time $t_r = 0,35 \text{ ns}$

Circuit capacitance $C \leq 1 \text{ pF}$ ($C = \text{oscilloscope input capacitance} + \text{parasitic capacitance}$)

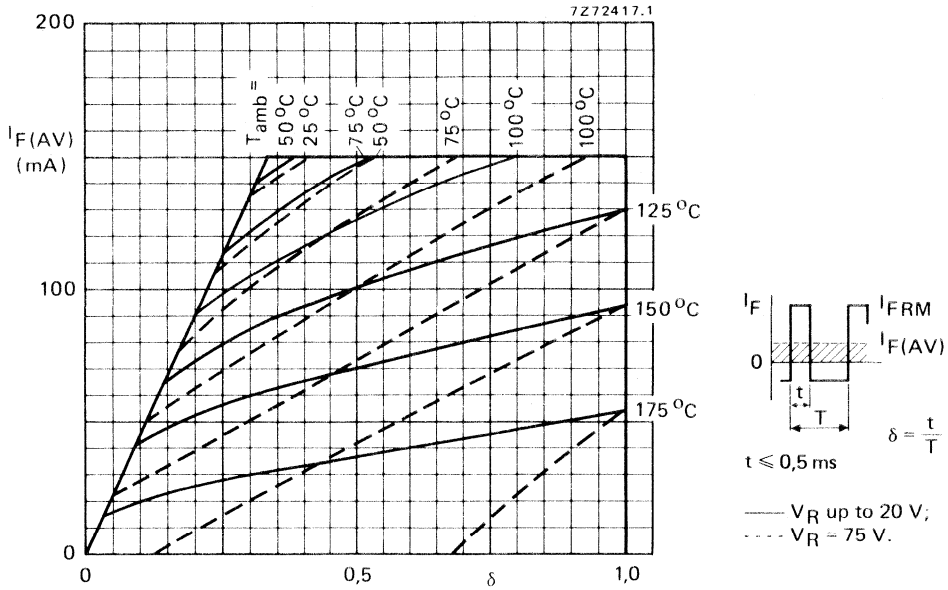

Fig. 4 Maximum permissible average rectified forward current versus duty factor (pulse operated).

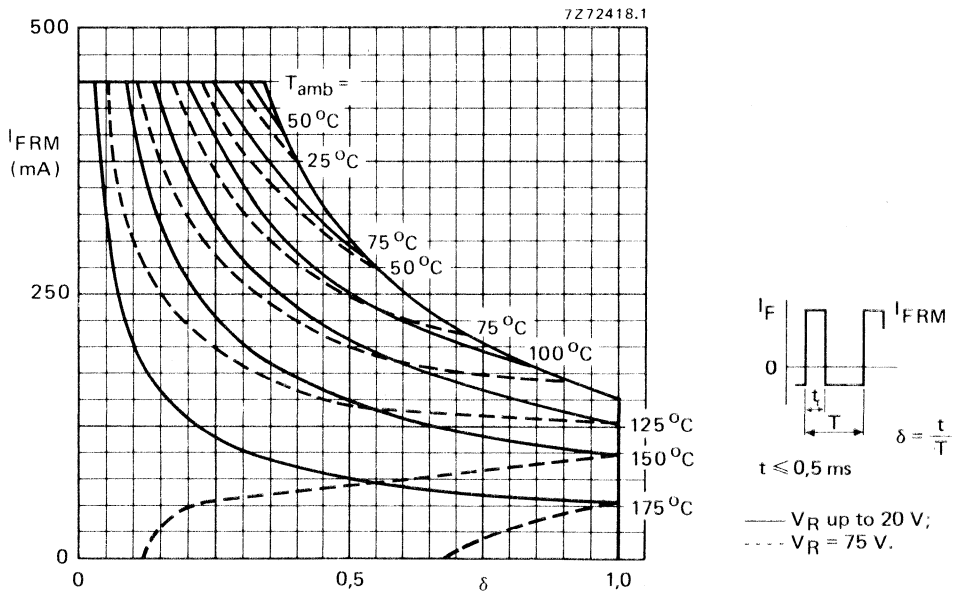

Fig. 5 Maximum permissible repetitive peak forward current versus duty factor (pulse operated).

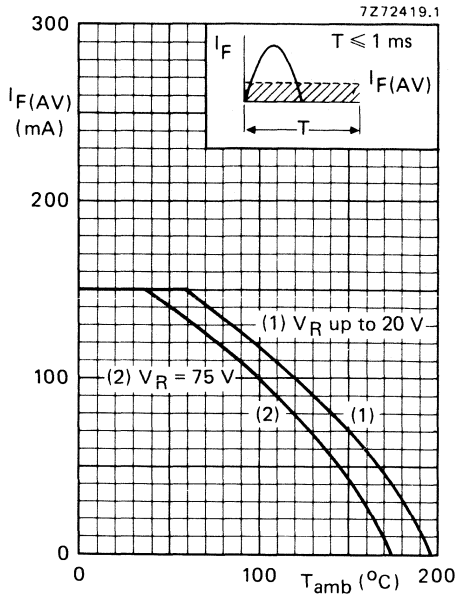

Fig. 6 Maximum permissible average rectified forward current versus ambient temperature.

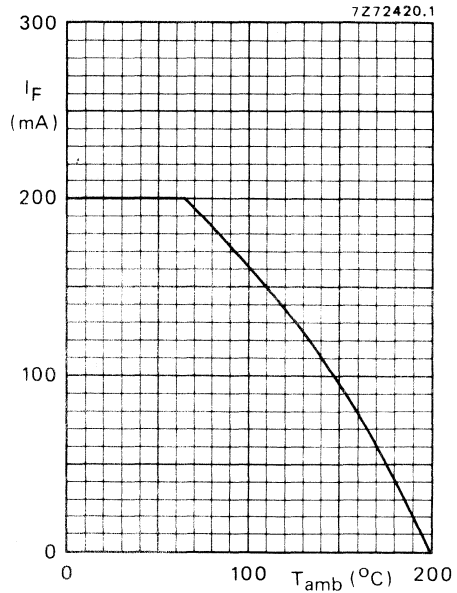

Fig. 7 Maximum permissible continuous forward current versus ambient temperature.

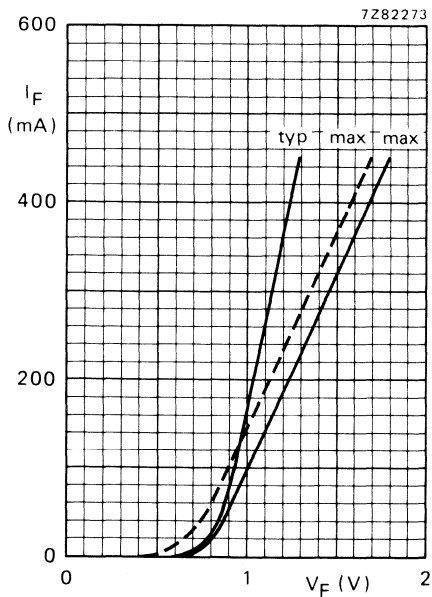

Fig. 8 Forward current versus forward voltage; — $T_j = 25$ $^{\circ}C$; - - - $T_j = 175$ $^{\circ}C$.

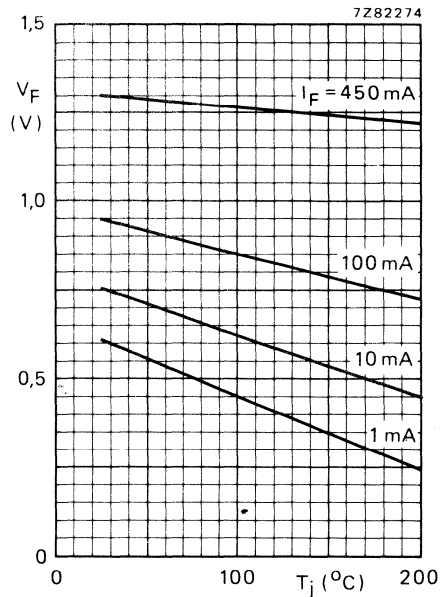

Fig. 9 Forward voltage versus junction temperature; typical values.

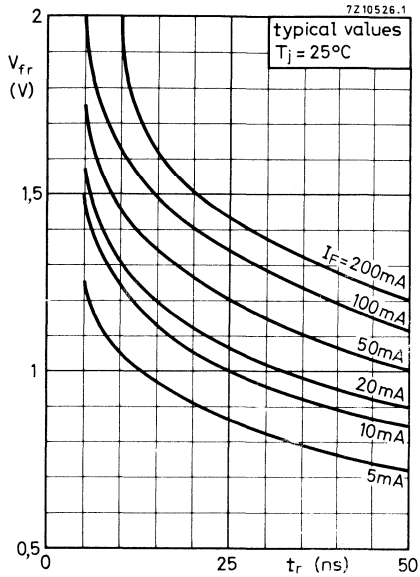

Fig. 10 Forward recovery voltage versus rise time.

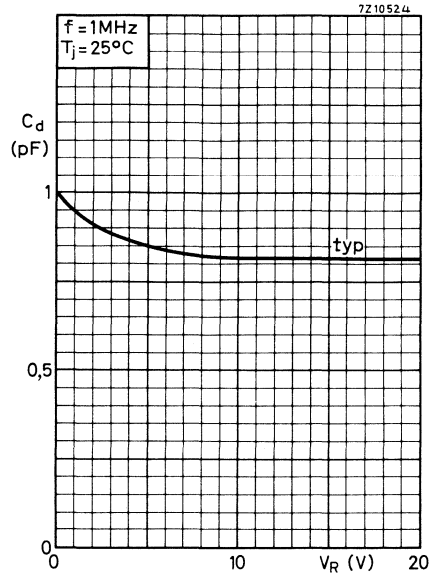

Fig. 11 Diode capacitance versus reverse voltage.

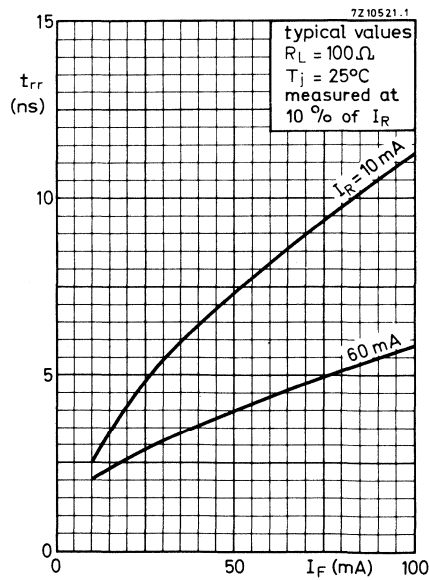

Fig. 12 Reverse recovery time versus forward current.

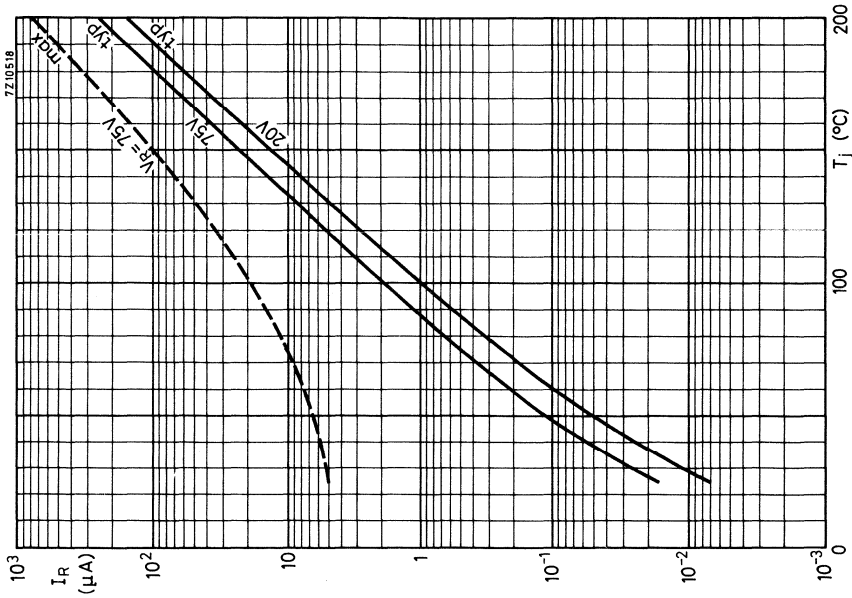

Fig. 14 Reverse current versus junction temperature.

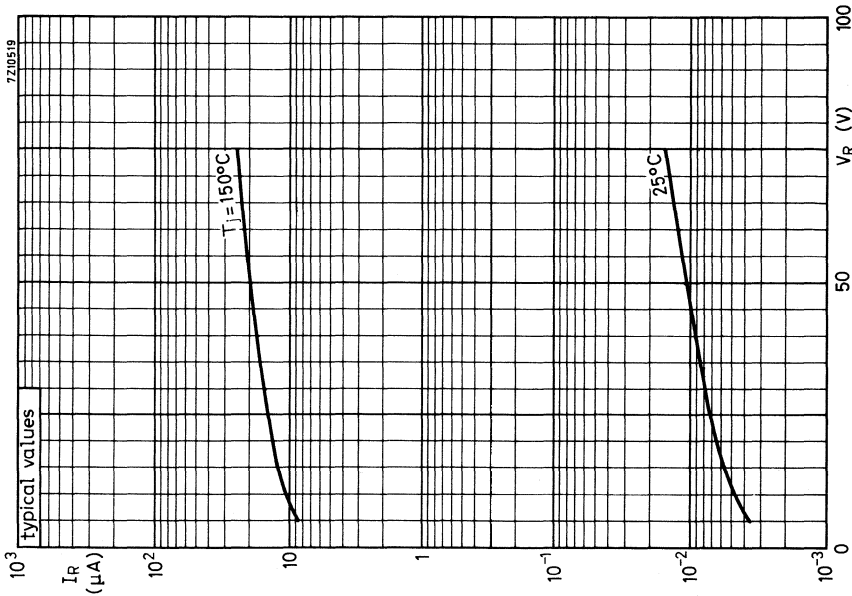

Fig. 13 Reverse current versus reverse voltage.

SILICON PLANAR EPITAXIAL ULTRA-HIGH SPEED DIODE

The BAS56 consists of two separate planar epitaxial ultra-high speed, high conductance diodes in one microminiature plastic envelope intended for surface mounting.

The device is primarily intended for core gating in very fast memories using the Surface Mounted Devices (SMD) technology.

QUICK REFERENCE DATA

			single diode	series connection
Continuous reverse voltage	V_R	max.	60	120 V
Repetitive peak reverse voltage	V_{RRM}	max.	60	120 V
Forward current	I_F	max.	200	150 mA
Repetitive peak forward current	I_{FRM}	max.	600	430 mA
Total power dissipation up to $T_{amb} = 25\text{ }^\circ\text{C}$	P_{tot}	max.	300	mW
Reverse recovery time when switched from $I_F = 400\text{ mA}$ to $I_R = 400\text{ mA}$; $R_L = 100\text{ }\Omega$; measured at $I_R = 40\text{ mA}$	t_{rr}	<	6	ns

MECHANICAL DATA

Fig. 1 SOT-143.

Dimensions in mm

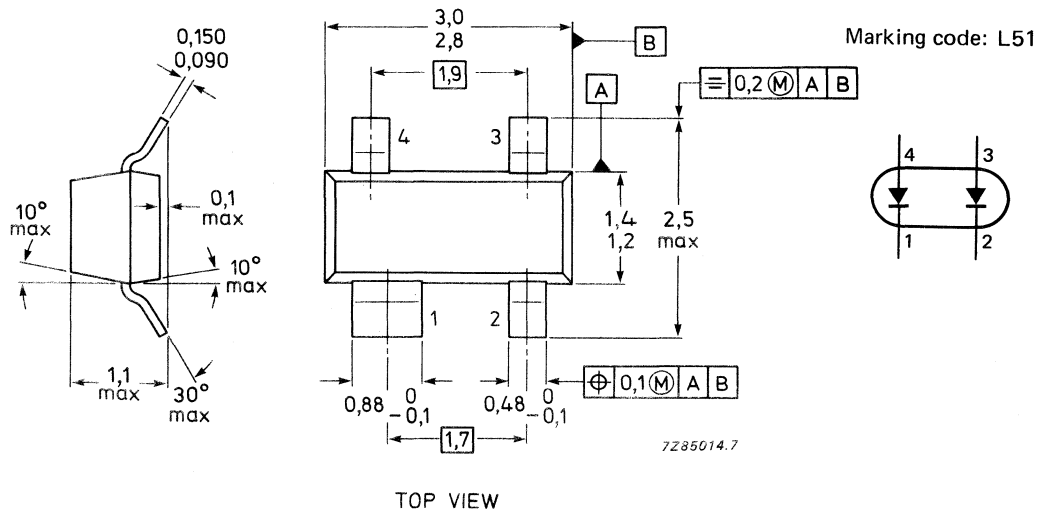

Marking code: L51

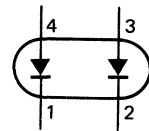

RATINGS

Limiting values in accordance with the Absolute Maximum System (IEC 134)

			single diode	series connection
Continuous reverse voltage	V_R	max.	60	120 V
Repetitive peak reverse voltage*	V_{RRM}	max.	60	120 V
Forward current	I_F	max.	200	150 mA
Repetitive peak forward current	I_{FRM}	max.	600	430 mA
→ Non-repetitive peak forward current (per crystal)				
$t = 1 \mu s$	I_{FSM}	max.	2000	mA
$t = 1 s$	I_{FSM}	max.	500	mA
Total power dissipation** up to $T_{amb} = 25 \text{ }^\circ\text{C}$	P_{tot}	max.	300	mW
Storage temperature range	T_{stg}		-65 to +150	$^\circ\text{C}$
Junction temperature	T_j	max.	150	$^\circ\text{C}$

THERMAL RESISTANCE

From junction to ambient**	$R_{th j-a}$	=	430	K/W
----------------------------	--------------	---	-----	-----

CHARACTERISTICS, per diode

$T_j = 25 \text{ }^\circ\text{C}$ unless otherwise specified

Forward voltage				
$I_F = 10 \text{ mA}$	V_F	<	0,75	V
$I_F = 200 \text{ mA}$	V_F	<	1,00	V
$I_F = 200 \text{ mA}; T_j = 100 \text{ }^\circ\text{C}$	V_F	<	0,95	V
$I_F = 500 \text{ mA}$	V_F	<	1,25	V
Reverse current				
$V_R = 60 \text{ V}$	I_R	<	100	nA
$V_R = 60 \text{ V}; T_j = 150 \text{ }^\circ\text{C}$	I_R	<	100	μA
Diode capacitance				
$V_R = 0; f = 1 \text{ MHz}$	C_d	<	2,5	pF

* Measured at zero life time at $I_R = 10 \mu\text{A}; V_R = 75 \text{ V}$.

** Mounted on a ceramic substrate of 10 mm x 8 mm x 0,6 mm.

Forward recovery voltage when switched to

$I_F = 400 \text{ mA}; t_{r1} = 30 \text{ ns}$
 $I_F = 400 \text{ mA}; t_{r2} = 100 \text{ ns}$

$V_{fr} < 120 \text{ V}$
 $< 1,5 \text{ V}$

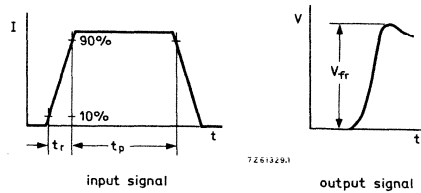
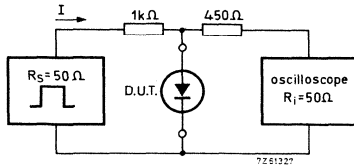

Fig. 2 Test circuit and waveforms; forward recovery voltage.

Input signal: 1st rise time of the forward pulse
 2nd rise time of the forward pulse
 Forward current pulse duration
 Duty factor

$t_{r1} = 30 \text{ ns}$
 $t_{r2} = 100 \text{ ns}$
 $t_p = 300 \text{ ns}$
 $\delta = 0,01$

Oscilloscope: Rise time
 Input capacitance

$t_r = 0,35 \text{ ns}$
 $C_i \leq 1 \text{ pF}$

Circuit capacitance $C \leq 20 \text{ pF}$ ($C = C_i + \text{parasitic capacitance}$)

Reverse recovery time when switched
 from $I_F = 400 \text{ mA}$ to $I_R = 40 \text{ mA}$;

$R_L = 100 \Omega$; measured at $I_R = 40 \text{ mA}$

$t_{rr} < 6 \text{ ns}$

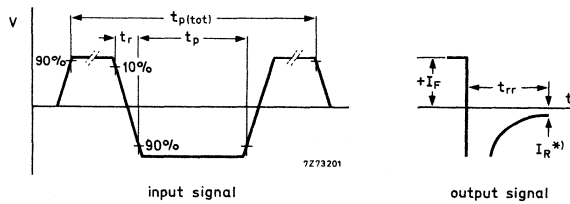
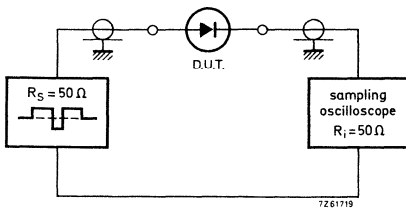

Fig. 3 Test circuits and waveforms; reverse recovery time.

* $I_R = 40 \text{ mA}$

Input signal: Total pulse duration
 Duty factor
 Rise time of the reverse pulse
 Reverse pulse duration

$t_{p(tot)} = 0,2 \mu\text{s}$
 $\delta = 0,0025$
 $t_r = 0,6 \text{ ns}$
 $t_p = 30 \text{ ns}$

Oscilloscope: Rise time

$t_r = 0,35 \text{ ns}$

Circuit capacitance $C \leq 1 \text{ pF}$ ($C = \text{oscilloscope input capacitance} + \text{parasitic capacitance}$)

Recovery charge when switched from
 $I_F = 10 \text{ mA}$ to $V_R = 5 \text{ V}$; $R_L = 500 \Omega$

$Q_s < 50 \text{ pC}$

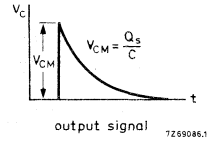
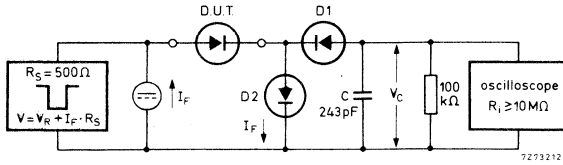

Fig. 4 Test circuit and waveform; recovery charge.

D1 = BAW62

D2 = diode with minority carrier life time at 10 mA

Input signal: Rise time of the reverse pulse

Reverse pulse duration

Duty factor

	<	200	ps
t_r	=	2	ns
t_p	=	400	ns
δ	=	0,02	

Circuit capacitance $C \leq 7 \text{ pF}$ ($C = \text{oscilloscope input capacitance} + \text{parasitic capacitance}$)

SCHOTTKY BARRIER DIODE

Silicon epitaxial diode in a microminiature plastic envelope. Intended for u.h.f. mixer and fast switching applications in thick and thin-film circuits.

QUICK REFERENCE DATA

Continuous reverse voltage	V_R	max.	4 V
Forward current (d.c.)	I_F	max.	30 mA
Junction temperature	T_j	max.	100 °C
Forward voltage at $I_F = 10$ mA	V_F	<	600 mV
Diode capacitance at $V_R = 0$; $f = 1$ MHz	C_d	<	1,0 pF
Noise figure at $f = 900$ MHz	F	<	8,0 dB

MECHANICAL DATA

Dimensions in mm

Marking code

BAT17 = A3

Fig.1 SOT-23.

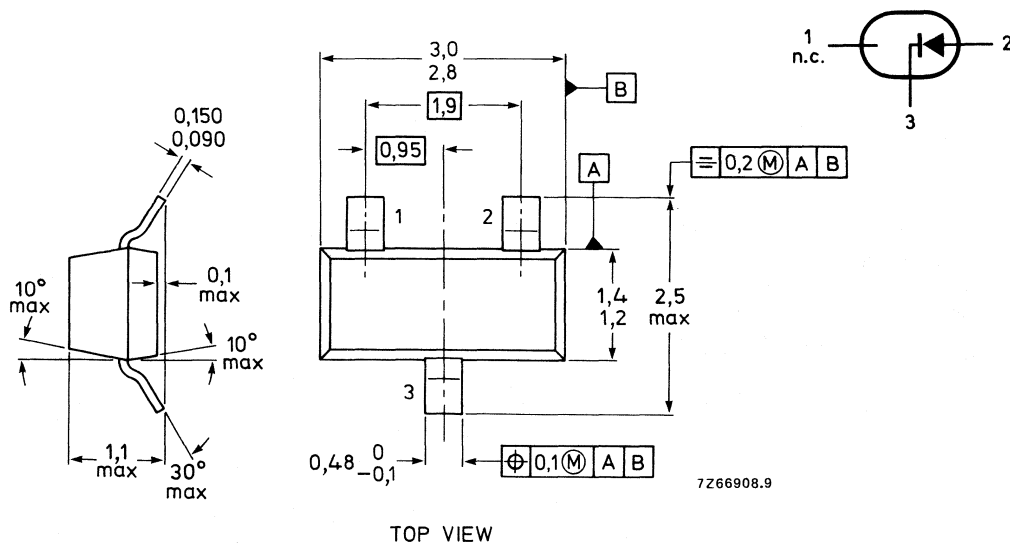

See also *Soldering recommendations*.

RATINGS

Limiting values in accordance with the Absolute Maximum System (IEC 134)

Continuous reverse voltage	V_R	max.	4 V
Forward current (d.c.)**	I_F	max.	30 mA
Storage temperature	T_{stg}		-65 to +100 °C
Junction temperature	T_j	max.	100 °C

THERMAL RESISTANCE*

From junction to ambient**	$R_{th\ j-a}$	=	430 K/W
----------------------------	---------------	---	---------

CHARACTERISTICS

$T_{amb} = 25\text{ °C}$ unless otherwise specified

Reverse current

$V_R = 3\text{ V}$

$I_R < 0,25\ \mu\text{A}$

$V_R = 3\text{ V}; T_{amb} = 60\text{ °C}$

$I_R < 1,25\ \mu\text{A}$

Reverse breakdown voltage

$I_R = 10\ \mu\text{A}$

$V_{(BR)R} > 4\text{ V}$

Forward voltage

$I_F = 0,1\text{ mA}$

$V_F < 350\text{ mV}$

$I_F = 1,0\text{ mA}$

$V_F < 450\text{ mV}$

$I_F = 10\text{ mA}$

$V_F < 600\text{ mV}$

Diode capacitance

$V_R = 0; f = 1\text{ MHz}$

$C_d < 1,0\text{ pF}$

Noise figure at $f = 900\text{ MHz}$ ▲

$F < 8,0\text{ dB}$

Series resistance at $f = 1\text{ kHz}$

$I_F = 5\text{ mA}$

$r_D < 15\ \Omega$

* See *Thermal characteristics*.

** Mounted on a ceramic substrate of 8 mm x 10 mm x 0,7 mm.

▲ The local oscillator is adjusted for a diode current of 2 mA. I.F. amplifier noise $F_{if} = 1,5\text{ dB}$; $f = 35\text{ MHz}$.

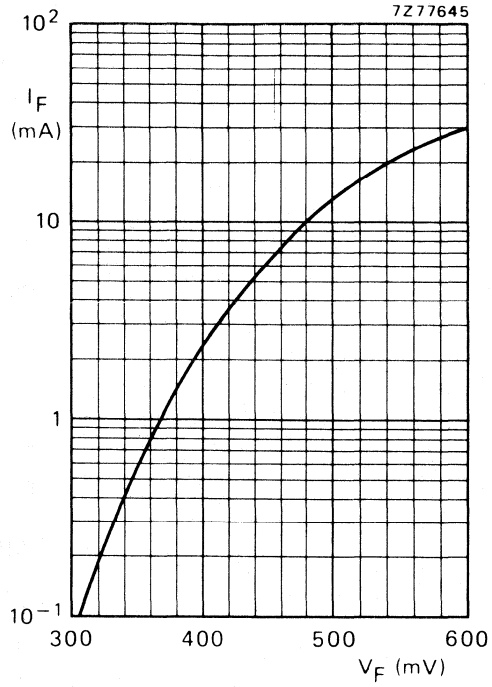

Fig. 2 Typical values.

RATINGS

Limiting values in accordance with the Absolute Maximum System (IEC 134)

Continuous reverse voltage	V_R	max.	35 V
Forward current (d.c.)	I_F	max.	100 mA
Storage temperature	T_{stg}		-55 to + 125 °C
Junction temperature	T_j	max.	125 °C

→ THERMAL RESISTANCE*

From junction to ambient**	$R_{th\ j-a}$	=	430 K/W
----------------------------	---------------	---	---------

CHARACTERISTICS

$T_j = 25\text{ °C}$ unless otherwise specified

Forward voltage at $I_F = 100\text{ mA}$

V_F	<	1,2 V
-------	---	-------

Reverse current

$V_R = 20\text{ V}$

I_R	<	100 nA
-------	---	--------

$V_R = 20\text{ V}; T_j = 60\text{ °C}$

I_R	<	1 μ A
-------	---	-----------

Diode capacitance at $f = 1\text{ MHz}$

$V_R = 20\text{ V}$

C_d	typ.	0,8 pF
	<	1,0 pF

Series resistance at $f = 200\text{ MHz}$

$I_F = 5\text{ mA}$

r_D	typ.	0,5 Ω
	<	0,7 Ω

* See *Thermal characteristics*.

** Mounted on a ceramic substrate of 8 mm x 10 mm x 0,7 mm.

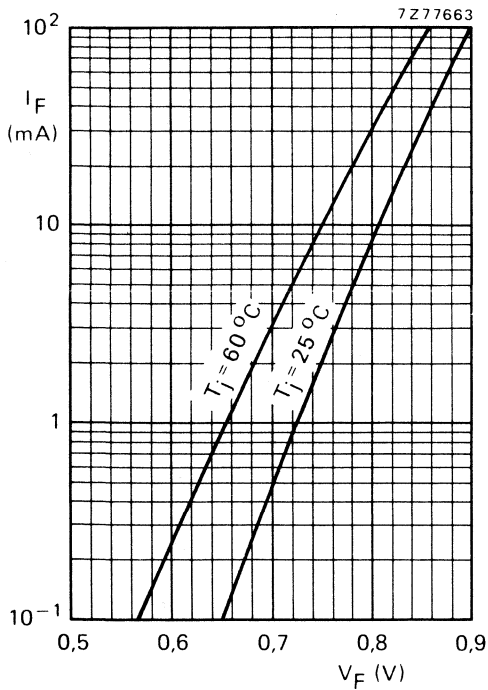

Fig. 2 Typical values.

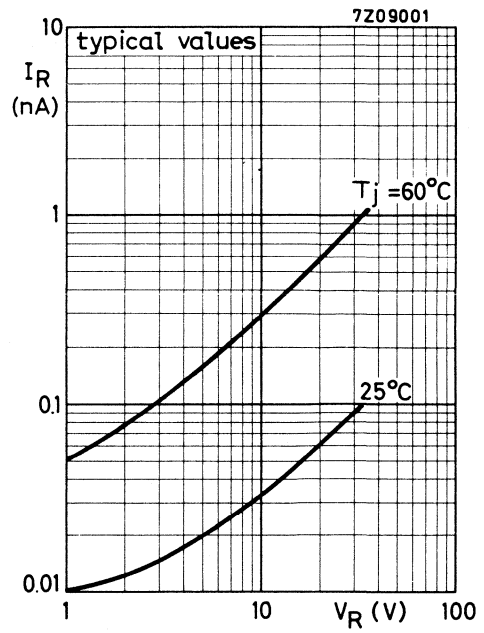

Fig. 3.

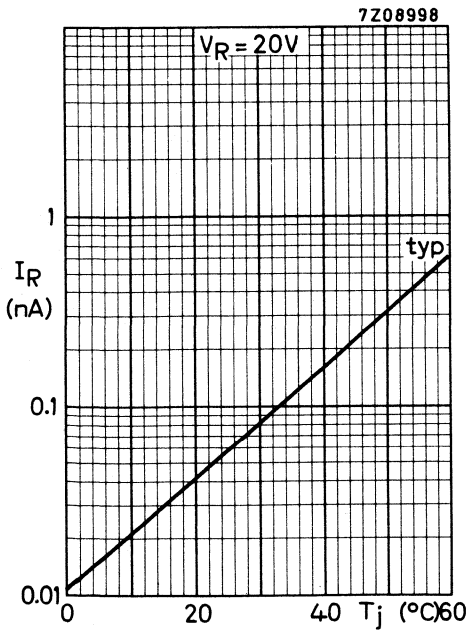

Fig. 4.

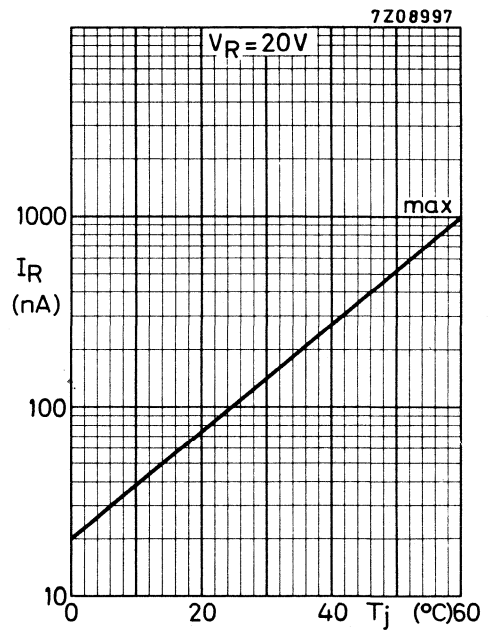

Fig. 5.

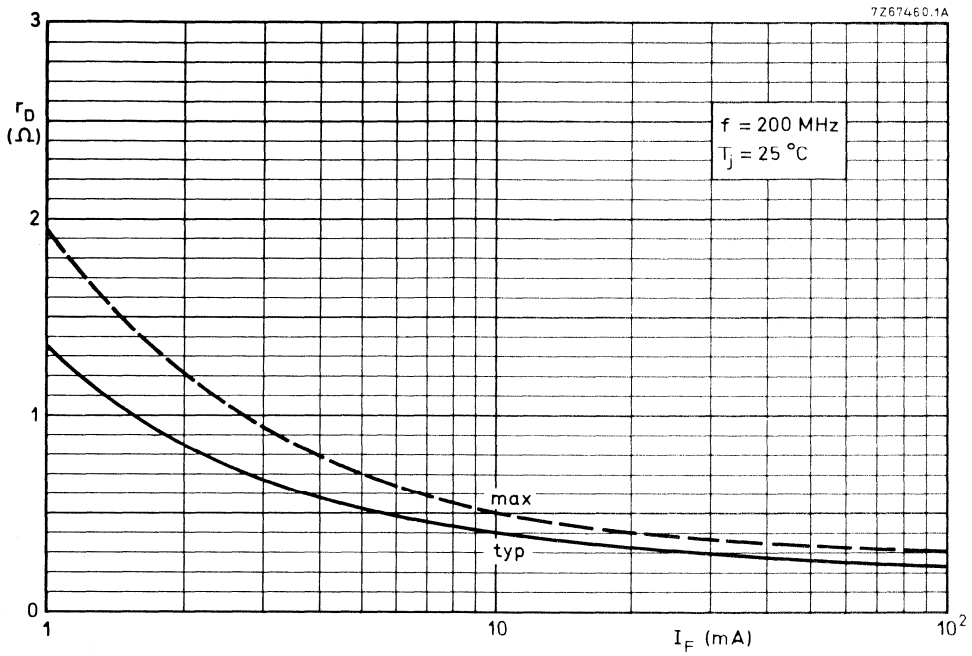

Fig. 6.

DEVELOPMENT DATA

This data sheet contains advance information and specifications are subject to change without notice.

BAT54

SCHOTTKY BARRIER DIODE

Silicon epitaxial Schottky barrier diode with an integrated p-n junction protection ring in a micro-miniature SOT-23 envelope intended for surface mounting.

The diode features especially a low forward voltage.

QUICK REFERENCE DATA

Continuous reverse voltage	V_R	max.	30	V
Forward current (d.c.)	I_F	max.	200	mA
Forward voltage at $I_F = 10$ mA	V_F	max.	400	mV
Total power dissipation up to $T_{amb} = 25$ °C	P_{tot}	max.	230	mW
Reverse recovery time when switched from $I_F = 10$ mA to $I_R = 10$ mA; $R_L = 100$ Ω ; measured at $I_R = 1$ mA	t_{rr}	\leq	5	ns
Junction temperature	T_j	max.	125	°C

Fig. 1 SOT-23

Dimensions in mm

Marking code: L4

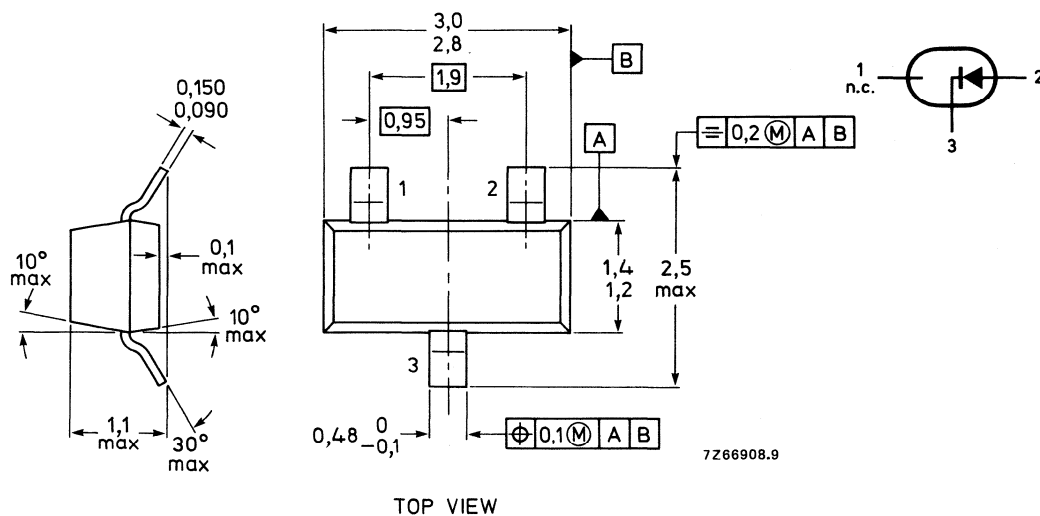

RATINGS

Limiting values in accordance with the Absolute Maximum System (IEC 134)

Continuous reverse voltage	V_R	max.	30	V
Forward current (d.c.) see Fig. 2	I_F	max.	200	mA
Repetitive peak forward current	I_{FRM}	max.	300	mA
Non-repetitive peak forward current $t < 1$ s	I_{FSM}	max.	600	mA
Total power dissipation up to $T_{amb} = 25$ °C	P_{tot}	max.	230	mW
Storage temperature	T_{stg}		-55 to +150	°C
Junction temperature	T_j	max.	125	°C

THERMAL RESISTANCE

From junction to ambient mounted on a ceramic substrate of 10 mm x 8 mm x 0,6 mm

$R_{th\ j-a}$	=	430	K/W
---------------	---	-----	-----

CHARACTERISTICS

$T_{amb} = 25$ °C unless otherwise specified

Forward voltage

$I_F = 0,1$ mA	V_F	≤	240	mV
$I_F = 1$ mA*	V_F	≤	320	mV
$I_F = 10$ mA	V_F	≤	400	mV
$I_F = 30$ mA*	V_F	≤	500	mV
$I_F = 100$ mA	V_F	=	500	mV
	V_F	<	1000	mV

Reverse current

$V_R = 25$ V	I_R	≤	2	μA
--------------	-------	---	---	----

Reverse breakdown voltage

$V_{(BR)R}$	>	30	V
-------------	---	----	---

Diode capacitance

$V_R = 1$ V; $f = 1$ MHz	C_d	≤	10	pF
--------------------------	-------	---	----	----

Reverse recovery time when switched from

$I_F = 10$ mA to $I_R = 10$ mA; $R_L = 100$ Ω; measured at $I_R = 1$ mA	t_{rr}	≤	5	ns
--	----------	---	---	----

* Temperature coefficient of forward voltage:

-0,6 %/K at $I_F = 1$ mA

-0,3 %/K at $I_F = 30$ mA

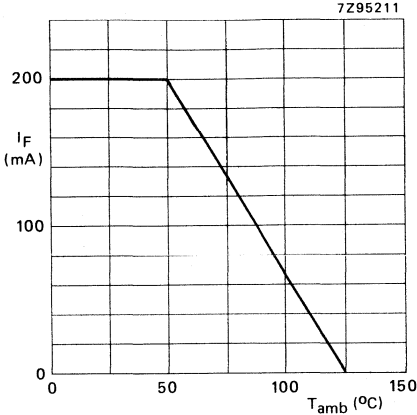

Fig. 2 Derating curve maximum ambient temperature.

DEVELOPMENT DATA

DEVELOPMENT DATA

This data sheet contains advance information and specifications are subject to change without notice.

BAT74

SCHOTTKY BARRIER DIODE

Two separate silicon epitaxial Schottky barrier diodes with an integrated p-n junction protection ring in one microminiature SOT-143 envelope, intended for surface mounting (SMD technology).

The device features a low forward voltage drop.

QUICK REFERENCE DATA

			single diode	double-diode operation
Continuous reverse voltage	V_R	max.	30	30 V
Continuous reverse voltage series connection	V_R	max.	—	60 V
Forward current	I_F	max.	200	110 mA
Repetitive peak forward current	I_{FRM}	max.	300	200 mA
Non-repetitive peak forward current	I_{FSM}	max.	600	mA
Total power dissipation up to $T_{amb} = 25^\circ C$	P_{tot}	max.	230	mW
Reverse recovery time when switched from $I_F = 10\text{ mA}$ to $I_R = 10\text{ mA}$; $R_L = 100\ \Omega$; measured at $I_R = 1\text{ mA}$	t_{rr}	\leq	5	ns

MECHANICAL DATA

Dimensions in mm

Fig. 1 SOT-143.

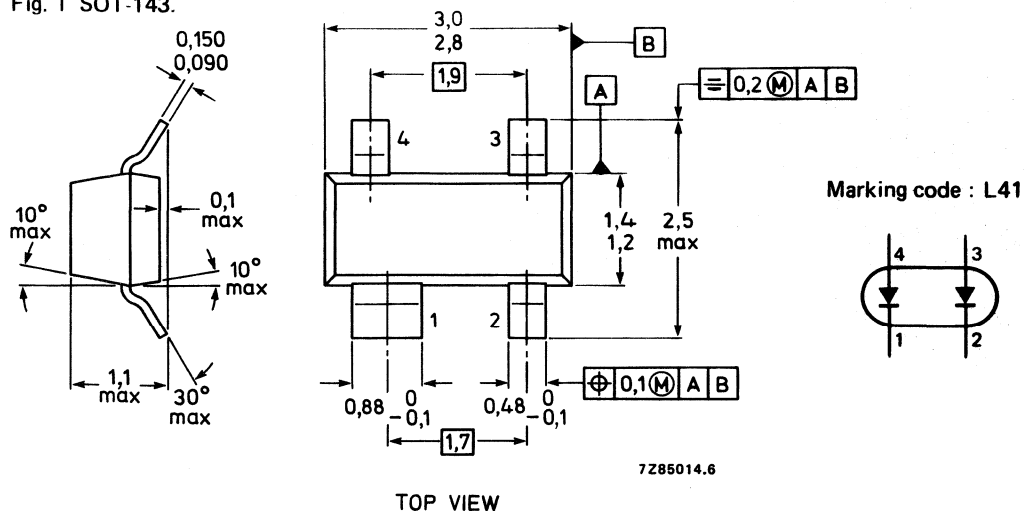

RATINGS

Limiting values in accordance with the Absolute Maximum System (IEC 134)

			single diode	double-diode operation
Continuous reverse voltage	V_R	max.	30	30 V
Continuous reverse voltage series connection	V_R	max.	—	60 V
Forward current (see Fig. 2)	I_F	max.	200	110* mA
Repetitive peak forward current	I_{FRM}	max.	300	200 mA
Non-repetitive peak forward current $t < 1$ s	I_{FSM}	max.	600	mA
Total power dissipation up to $T_{amb} = 25$ °C	P_{tot}	max.	230	mW
Storage temperature	T_{stg}		-65 to + 150	°C
Junction temperature	T_j	max.	125	°C

THERMAL RESISTANCE

From junction to ambient mounted on a ceramic substrate of 10 mm x 8 mm x 0,6 mm

$R_{th j-a}$	430	K/W
--------------	-----	-----

CHARACTERISTICS, per diode

$T_{amb} = 25$ °C unless otherwise specified

Forward voltage

$I_F = 0,1$ mA	V_F	\leq	240	mV
$I_F = 1$ mA**	V_F	\leq	320	mV
$I_F = 10$ mA	V_F	\leq	400	mV
$I_F = 30$ mA**	V_F	\leq	500	mV
$I_F = 100$ mA	V_F	\leq	500	mV
		$<$	1000	mV

Reverse current

$V_R = 25$ V	I_R	\leq	2	μ A
--------------	-------	--------	---	---------

Reverse breakdown voltage

$V_{(BR)R}$	$>$	30	V
-------------	-----	----	---

Diode capacitance

$V_R = 1$ V; $f = 1$ MHz	C_d	\leq	10	pF
--------------------------	-------	--------	----	----

Reverse recovery time when switched from

$I_F = 10$ mA to $I_R = 10$ mA; $R_L = 100$ Ω ; measured at $I_R = 1$ mA	t_{rr}	\leq	5	ns
--	----------	--------	---	----

* If both diodes are in forward operation at the same moment, total device current max. 110 mA. If one diode is in reverse and the other in forward operation at the same moment, total device current max. 200 mA.

** Temperature coefficient of forward voltage: $-0,6\%/K$ at $I_F = 1$ mA.

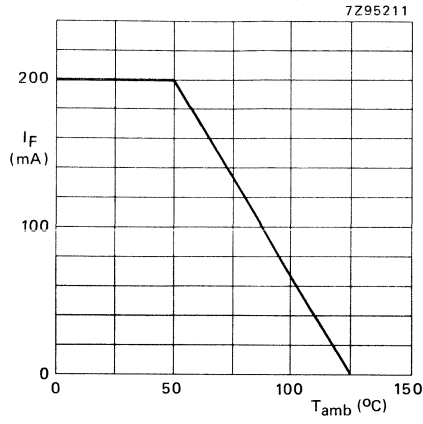

Fig. 2 Derating curve maximum ambient temperature.

DEVELOPMENT DATA

DEVELOPMENT DATA

This data sheet contains advance information and specifications are subject to change without notice.

BAV23

SILICON PLANAR EPITAXIAL HIGH-SPEED DIODE

The BAV23 consists of two separate planar epitaxial high-speed diodes in one microminiature plastic envelope intended for surface mounting.

The device is designed for switching and general applications where high breakdown voltages are required.

QUICK REFERENCE DATA

			single diode	series connection
Continuous reverse voltage	V_R	max.	200	400 V
Repetitive peak reverse voltage	V_{RRM}	max.	250	500 V
Average forward current	$I_F(AV)$	max.	200	120 mA
Repetitive peak forward current	I_{FRM}	max.	625	450 mA
Total power dissipation up to $T_{amb} = 25\text{ }^\circ\text{C}$	P_{tot}	max.	300	mW
Reverse recovery time when switched from $I_F = 30\text{ mA}$ to $I_R = 30\text{ mA}$; $R_L = 100\text{ }\Omega$; measured at $I_R = 3\text{ mA}$	t_{rr}	<	50	ns

MECHANICAL DATA

Fig. 1 SOT-143.

Dimensions in mm
Marking code: L30

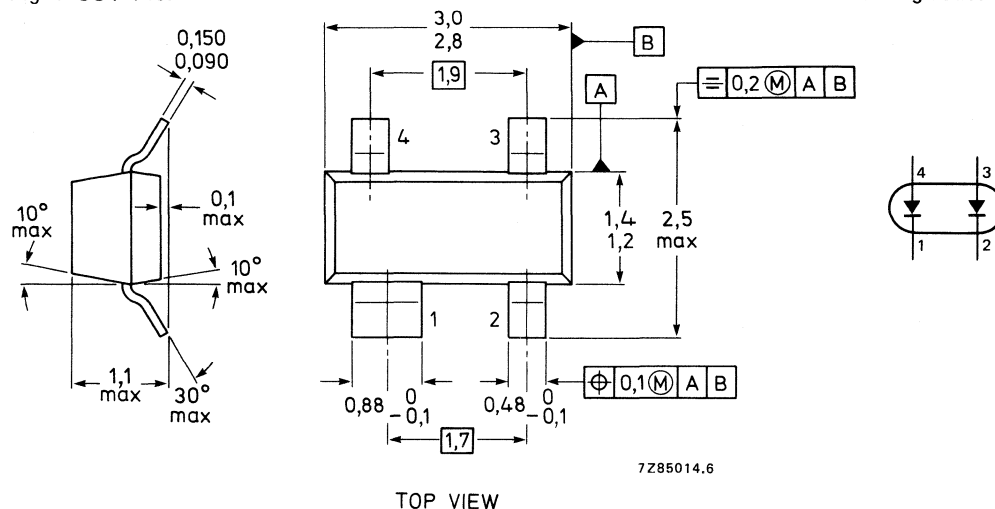

RATINGS

Limiting values in accordance with the Absolute Maximum System (IEC 134)

			single diode	series connection
Continuous reverse voltage	V_R	max.	200	400 V
Repetitive peak reverse voltage	V_{RRM}	max.	250	500 V
Average forward current	$I_F(AV)$	max.	200	120 mA
Repetitive peak forward current	I_{FRM}	max.	625	450 mA
Total power dissipation up to $T_{amb} = 25\text{ }^\circ\text{C}$	P_{tot}	max.	300	mW
Storage temperature	T_{stg}		-65 to +150	$^\circ\text{C}$
Junction temperature	T_j	max.	150	$^\circ\text{C}$

THERMAL RESISTANCE

From junction to ambient on a ceramic
substrate of 8 mm x 10 mm x 0,6 mm

$R_{th\ j-a}$	430	K/W
---------------	-----	-----

CHARACTERISTICS

$T_j = 25\text{ }^\circ\text{C}$ unless otherwise specified

			single diode	series connection
Forward voltage				
$I_F = 100\text{ mA}$	V_F	<	1000	2000 mV
$I_F = 200\text{ mA}$		<	1250	2500 mV
Reverse current				
$V_R = V_{Rmax}$	I_R	<	100	100 nA
Reverse breakdown voltage				
$I_R = 100\text{ }\mu\text{A}$	$V_{(BR)R}$	>	250	500 V
Differential forward resistance				
$I_F = 10\text{ mA}$	r_f	typ.	5	10 Ω
Diode capacitance				
$V_R = 0$; $f = 1\text{ MHz}$	C_d	<	5	2,5 pF
Reverse recovery time when switched from $I_F = 30\text{ mA}$ to $I_R = 30\text{ mA}$; $R_L = 100\text{ }\Omega$; measured at $I_R = 3\text{ mA}$	t_{rr}	<	50	50 ns

SILICON PLANAR EPITAXIAL HIGH-SPEED DIODES

The BAV70 consists of two diodes in a microminiature plastic envelope. The cathodes are commoned and the unit is intended for high-speed switching in thick and thin-film circuits.

QUICK REFERENCE DATA (per diode)

Continuous reverse voltage	V_R	max.	70 V
Repetitive peak reverse voltage	V_{RRM}	max.	70 V
Repetitive peak forward current	I_{FRM}	max.	250 mA
Junction temperature	T_j	max.	175 °C
Forward voltage at $I_F = 50$ mA	V_F	<	1,0 V
Reverse recovery time when switched from $I_F = 10$ mA to $I_R = 10$ mA; $R_L = 100 \Omega$; measured at $I_R = 1$ mA	t_{rr}	<	6 ns
Recovery charge when switched from $I_F = 10$ mA to $V_R = 5$ V; $R_L = 500 \Omega$	Q_s	<	45 pC

MECHANICAL DATA

Fig. 1 SOT-23.

Dimensions in mm

Marking code

BAV70 = A4

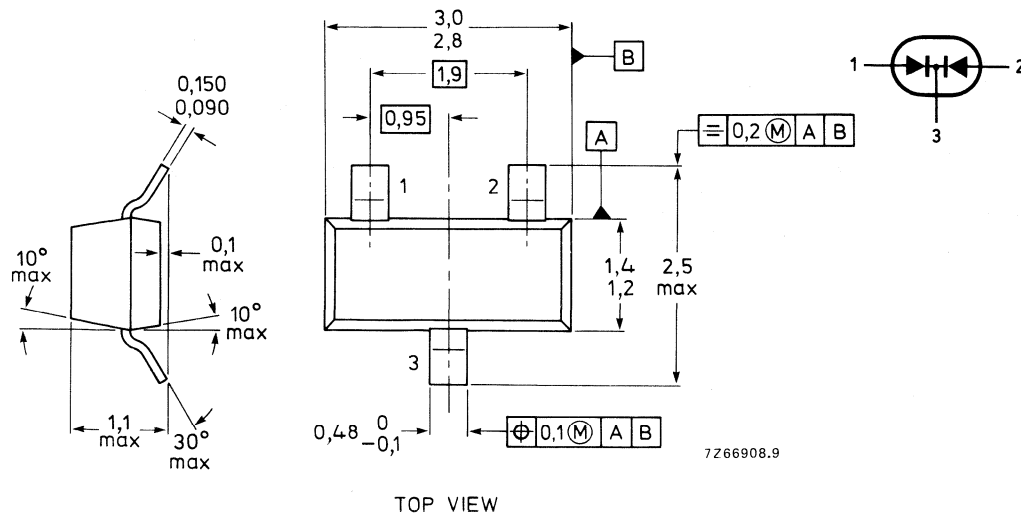

See also *Soldering recommendations*.

RATINGS (per diode)

Limiting values in accordance with the Absolute Maximum System (IEC 134)

Continuous reverse voltage	V_R	max.	70 V
Repetitive peak reverse voltage	V_{RRM}	max.	70 V
Average rectified forward current [▲] (averaged over any 20 ms period)	$I_{F(AV)}$	max.	250 mA
Forward current (d.c.)	I_F	max.	250 mA
Repetitive peak forward current	I_{FRM}	max.	250 mA
→ Non-repetitive peak forward current (per crystal)			
$t = 1 \mu s$	I_{FSM}	max.	2 A
$t = 1 ms$	I_{FSM}	max.	1 A
$t = 1 s$	I_{FSM}	max.	0,5 A
Storage temperature range	T_{stg}		-65 to + 175 °C
Junction temperature	T_j	max.	175 °C

THERMAL RESISTANCE*

From junction to ambient**	R_{thj-a}	=	430 K/W
----------------------------	-------------	---	---------

CHARACTERISTICS (per diode)

$T_j = 25 \text{ °C}$ unless otherwise specified

Forward voltage

$I_F = 1 \text{ mA}$	V_F	<	715 mV
$I_F = 10 \text{ mA}$	V_F	<	855 mV
$I_F = 50 \text{ mA}$	V_F	<	1000 mV
$I_F = 150 \text{ mA}$	V_F	<	1250 mV

Reverse current

$V_R = 25 \text{ V}; T_j = 150 \text{ °C}$	I_R	<	60 μA
$V_R = 70 \text{ V}$	I_R	<	5 μA
$V_R = 70 \text{ V}; T_j = 150 \text{ °C}$	I_R	<	100 μA

Diode capacitance

$V_R = 0; f = 1 \text{ MHz}$	C_d	<	1,5 pF
------------------------------	-------	---	--------

Forward recovery voltage when switched to

$I_F = 10 \text{ mA}; t_r = 20 \text{ ns}$	V_{fr}	<	1,75 V
--	----------	---	--------

▲ Measured under pulse conditions : pulse time $t_p \leq 0,5 \text{ ms}$.
For sinusoidal operation $I_{F(AV)} = 150 \text{ mA}$; averaging time $t_{(av)} \leq 1 \text{ ms}$.

* See *Thermal characteristics*.

**Mounted on a ceramic substrate of 8 mm x 10 mm x 0,7 mm.

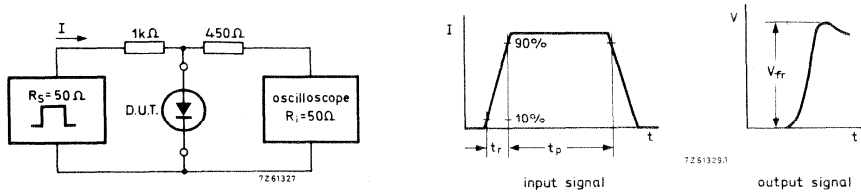

Fig. 2 Test circuit and waveforms; forward recovery voltage.

Input signal : Rise time of the forward pulse $t_r = 20$ ns; Forward current pulse duration $t_p = 120$ ns;

Duty factor $\delta = 0,01$

Oscilloscope : Rise time $t_r = 0,35$ ns

Circuit capacitance $C \leq 1$ pF ($C =$ oscilloscope input capacitance + parasitic capacitance)

Reverse recovery time when switched from

$I_F = 10$ mA to $I_R = 10$ mA; $R_L = 100 \Omega$;

measured at $I_R = 1$ mA

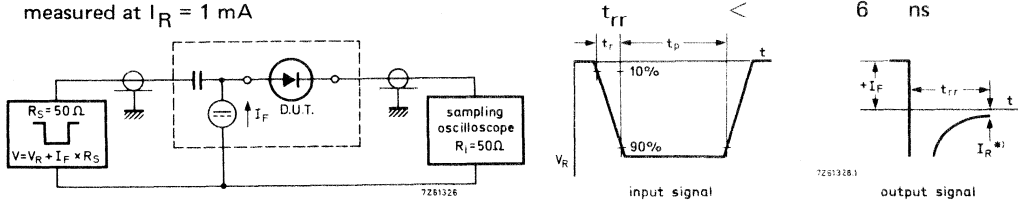

Fig. 3 Test circuit and waveforms; reverse recovery time.

Input signal : Rise time of the reverse pulse $t_r = 0,6$ ns; reverse pulse

duration $t_p = 100$ ns; duty factor $\delta = 0,05$

Oscilloscope : Rise time $t_r = 0,35$ ns

Circuit capacitance $C \leq 1$ pF ($C =$ oscilloscope input capacitance + parasitic capacitance)

Recovery charge when switched from

$I_F = 10$ mA to $V_R = 5$ V; $R_L = 500 \Omega$

$Q_s < 45$ pC

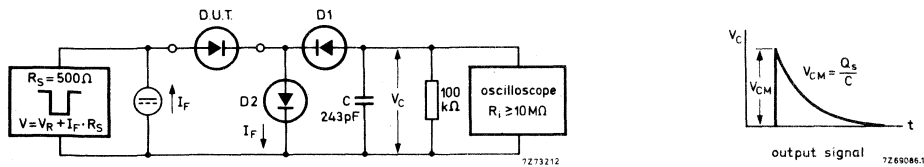

Fig. 4 Test circuit and waveform; recovery charge.

D1 = BAW62

D2 = diode with minority carrier life time at 10 mA: < 200 ps

Input signal : Rise time of the reverse pulse = $t_r = 2$ ns; Reverse pulse duration = $t_p = 400$ ns;

Duty factor = $\delta = 0,02$

Circuit capacitance $C \leq 7$ pF ($C =$ oscilloscope input capacitance + parasitic capacitance)

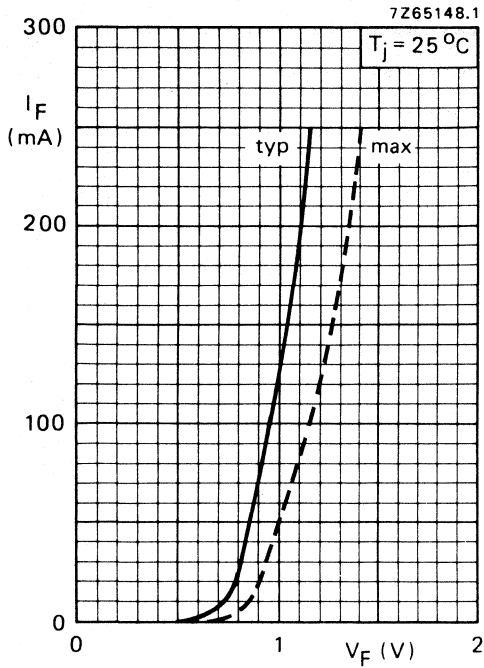

Fig. 5

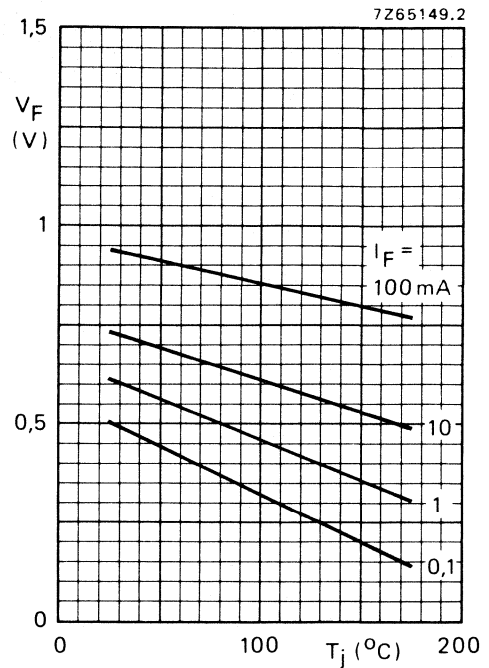

Fig. 6

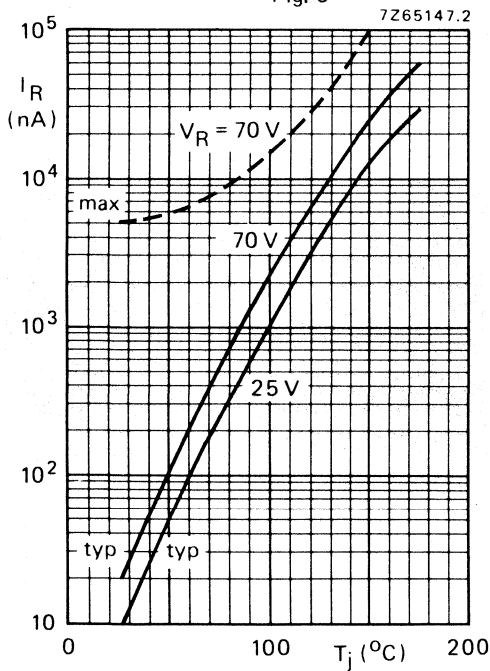

Fig. 7

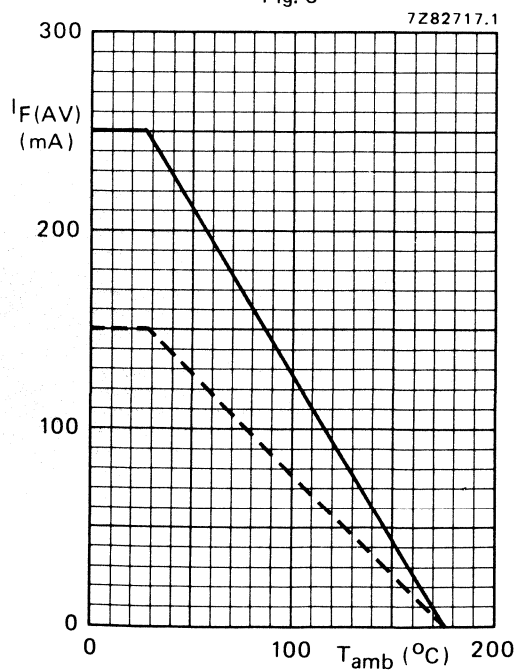

Fig. 8 — single diode
- - - double diode, equally loaded.

SILICON PLANAR EPITAXIAL HIGH-SPEED DIODES

The BAV99 consists of two diodes in a microminiature plastic envelope. The diodes are connected in series and the unit is intended for high-speed switching in thick and thin-film circuits.

QUICK REFERENCE DATA (per diode)

Continuous reverse voltage	V_R	max.	70 V
Repetitive peak reverse voltage	V_{RRM}	max.	70 V
Repetitive peak forward current	I_{FRM}	max.	250 mA
Junction temperature	T_j	max.	175 °C
Forward voltage at $I_F = 50$ mA	V_F	<	1,0 V
Reverse recovery time when switched from $I_F = 10$ mA to $I_R = 10$ mA; $R_L = 100 \Omega$; measured at $I_R = 1$ mA	t_{rr}	<	6 ns
Recovery charge when switched from $I_F = 10$ mA to $V_R = 5$ V; $R_L = 500 \Omega$	Q_s	<	45 pC

MECHANICAL DATA

Fig. 1 SOT-23.

Dimensions in mm

Marking code

BAV99 = A7

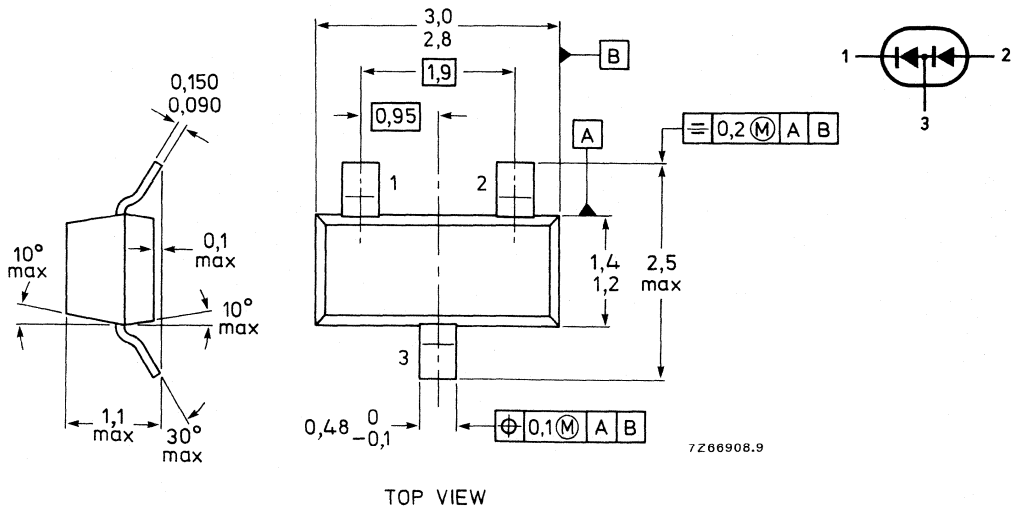

See also *Soldering recommendations*.

RATINGS (per diode)

Limiting values in accordance with the Absolute Maximum System (IEC 134)

Continuous reverse voltage	V_R	max.	70 V
Repetitive peak reverse voltage	V_{RRM}	max.	70 V
Average rectified forward current [▲] (averaged over any 20 ms period)	$I_{F(AV)}$	max.	250 mA
Forward current (d.c.)	I_F	max.	250 mA
Repetitive peak forward current	I_{FRM}	max.	250 mA
→ Non-repetitive peak forward current (per crystal)			
$t = 1 \mu s$	I_{FRM}	max.	2 A
$t = 1 ms$	I_{FRM}	max.	1 A
$t = 1 s$	I_{FRM}	max.	0,5 A
Storage temperature range	T_{stg}		-65 to + 175 °C
Junction temperature	T_j	max.	175 °C

THERMAL RESISTANCE*

From junction to ambient**	R_{thj-a}	=	430 K/W
----------------------------	-------------	---	---------

CHARACTERISTICS (per diode) $T_j = 25 \text{ °C}$ unless otherwise specified

Forward voltage			
$I_F = 1 \text{ mA}$	V_F	<	715 mV
$I_F = 10 \text{ mA}$	V_F	<	855 mV
$I_F = 50 \text{ mA}$	V_F	<	1000 mV
$I_F = 150 \text{ mA}$	V_F	<	1250 mV
Reverse current			
$V_R = 25 \text{ V}; T_j = 150 \text{ °C}$	I_R	<	30 μA
$V_R = 70 \text{ V}$	I_R	<	2,5 μA
$V_R = 70 \text{ V}; T_j = 150 \text{ °C}$	I_R	<	50 μA
Diode capacitance			
$V_R = 0; f = 1 \text{ MHz}$	C_d	<	1,5 pF
Forward recovery voltage when switched to $I_F = 10 \text{ mA}; t_r = 20 \text{ ns}$	V_{fr}	<	1,75 V

[▲] Measured under pulse conditions: pulse time $t_p \leq 0,5 \text{ ms}$.For sinusoidal operation $I_{F(AV)} = 150 \text{ mA}$; averaging time $t_{(av)} \leq 1 \text{ ms}$.* See *Thermal characteristics*.

** Mounted on a ceramic substrate of 8 mm x 10 mm x 0,7 mm.

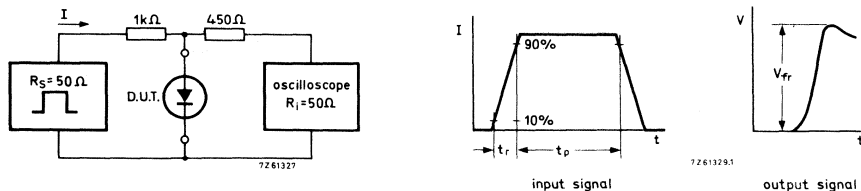

Fig. 2 Test circuit and waveforms; forward recovery voltage.

Input signal: Rise time of the forward pulse $t_r = 20$ ns;
 Forward current pulse duration $t_p = 120$ ns. Duty factor $\delta = 0,01$.
 Oscilloscope: Rise time $t_r = 0,35$ ns.
 Circuit capacitance $C \leq 1$ pF ($C =$ oscilloscope input capacitance + parasitic capacitance).
 Reverse recovery time when switched from
 $I_F = 10$ mA to $I_R = 10$ mA; $R_L = 100 \Omega$;
 measured at $I_R = 1$ mA

$$t_{rr} < 6 \text{ ns}$$

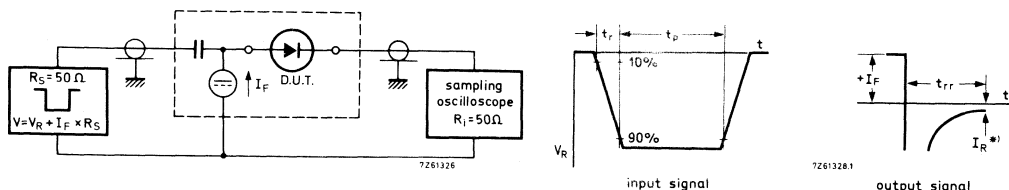

Fig. 3 Test circuit and waveforms; reverse recovery time.

Input signal: Rise time of the reverse pulse $t_r = 0,6$ ns
 Reverse pulse duration $t_p = 100$ ns. Duty factor $\delta = 0,05$.
 Oscilloscope: Rise time $t_r = 0,35$ ns.
 Circuit capacitance $C \leq 1$ pF ($C =$ oscilloscope input capacitance + parasitic capacitance).
 Recovery charge when switched from
 $I_F = 10$ mA to $V_R = 5$ V; $R_L = 500 \Omega$

*) $I_R = 1$ mA

$$Q_s < 45 \text{ pC}$$

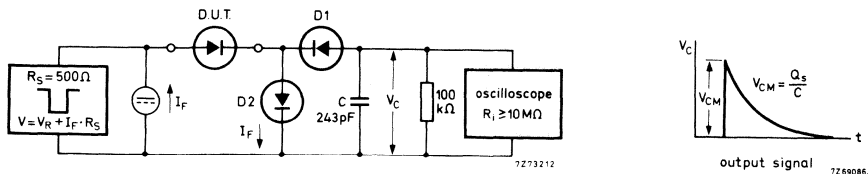

Fig. 4 Test and waveform; recovery charge.

$D2 =$ diode with minority carrier life time at 10 mA: < 200 ps; $D1 =$ BAV62.
 Input signal: Rise time of the reverse pulse $t_r = 2$ ns
 Reverse pulse duration $t_p = 400$ ns. Duty factor $\delta = 0,02$.
 Circuit capacitance $C \leq 7$ pF ($C =$ oscilloscope input capacitance + parasitic capacitance).

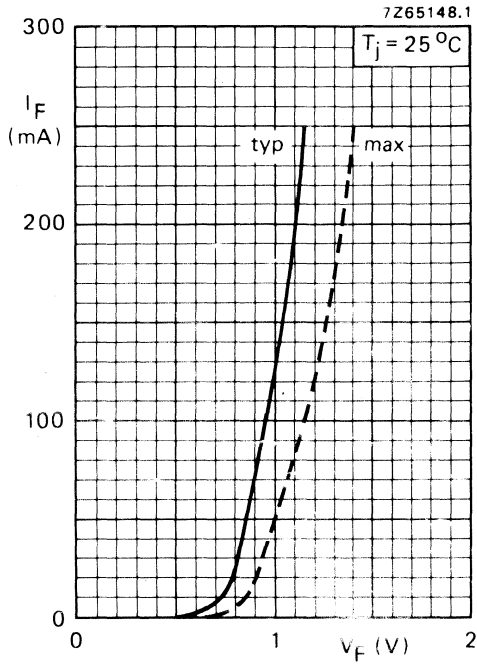

Fig. 5.

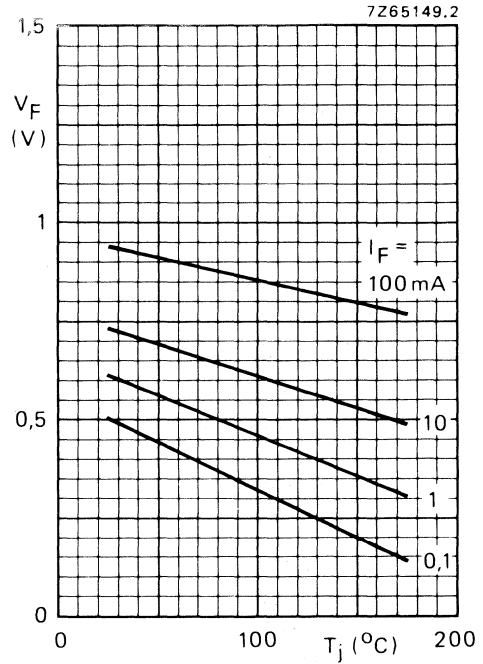

Fig. 6 Typical values.

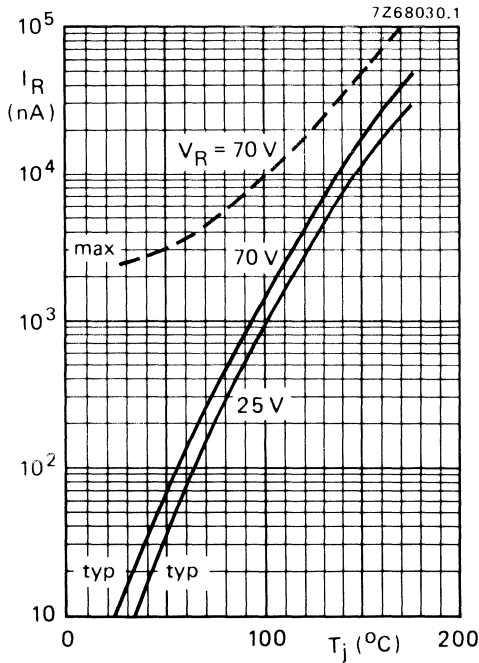

Fig. 7.

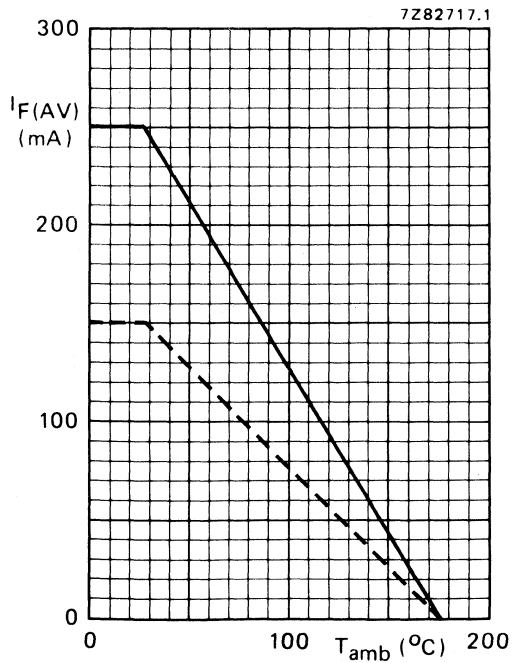

Fig. 8 — single diode
----- double diode; equally loaded.

DEVELOPMENT DATA

This data sheet contains advance information and specifications are subject to change without notice.

BAV100 to 103

GENERAL PURPOSE DIODES FOR SURFACE MOUNTING

Silicon planar epitaxial diodes; intended for switching and general purposes in industrial equipment e.g. oscilloscopes, digital voltmeters and video output stages in colour television.

The SM DIODE is a leadless diode in an hermetically sealed glass envelope with tin plated metal discs at each end. It is suitable for Automatic Placement and as such it can withstand immersion soldering.

The diodes are delivered in "super 8" tape.

QUICK REFERENCE DATA

		BAV100	BAV101	BAV102	BAV103
Continuous reverse voltage	V_R max.	50	100	150	200 V
Forward current (d.c.)	I_F max.	250			mA
Junction temperature	T_j max.	175			°C
Thermal resistance from junction to ambient	R_{thj-a}	0,375			K/mW
Forward voltage at $I_F = 100$ mA	V_F	< 1,0			V
Reverse current at $V_R = V_{Rmax}$	I_R	< 100			nA
Diode capacitance at $V_R = 0$; $f = 1$ MHz	C_d	typ. < 1,5			pF
Reverse recovery time when switched from $I_F = 30$ mA to $I_R = 30$ mA; $R_L = 100 \Omega$; measured at $I_R = 3$ mA	t_{rr}	< 50			ns

MECHANICAL DATA

Fig. 1 SOD-80.

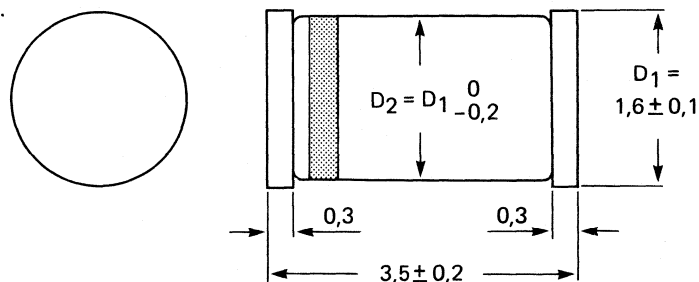

Dimensions in mm

7Z91084.1

The BAV100 cathode is indicated by a green and a black band.
 The BAV101 cathode is indicated by a green and a brown band.
 The BAV102 cathode is indicated by a green and a red band.
 The BAV103 cathode is indicated by a green and an orange band.

RATINGS

Limiting values in accordance with the Absolute Maximum System (IEC 134)

			BAV100	BAV101	BAV102	BAV103	
Continuous reverse voltage	V_R	max.	50	100	150	200	V
Repetitive peak reverse voltage	V_{RRM}	max.	60	120	200	250	V
Average rectified forward current	$I_F(AV)$	max.	250				$\text{mA}^1)$
Forward current (d.c.)	I_F	max.	250				mA
Repetitive peak forward current	I_{FRM}	max.	625				mA
Non-repetitive peak forward current							
$t < 1 \text{ s}; T_j = 25 \text{ }^\circ\text{C}$	I_{FSM}	max.	1				A
$t = 1 \text{ } \mu\text{s}; T_j = 25 \text{ }^\circ\text{C}$	I_{FSM}	max.	5				A
Total power dissipation up to $T_{amb} = 25 \text{ }^\circ\text{C}$	P_{tot}	max.	400				mW
Storage temperature	T_{stg}		-65 to +175				$^\circ\text{C}$
Junction temperature	T_j	max.	175				$^\circ\text{C}$

THERMAL RESISTANCE

From junction to ambient in free air	$R_{th j-a}$	=	0,375				K/mW
--------------------------------------	--------------	---	-------	--	--	--	---------------

CHARACTERISTICS

$T_j = 25 \text{ }^\circ\text{C}$ unless otherwise specified

			BAV100	BAV101	BAV102	BAV103	
Forward voltage							
$I_F = 100 \text{ mA}$	V_F	<	1,0				V
$I_F = 200 \text{ mA}$	V_F	<	1,25				V
Reverse breakdown voltage							
$I_R = 100 \text{ } \mu\text{A}$	$V_{(BR)R}$	>	60	120	200	250	$\text{V}^2)$
Reverse current							
$V_R = V_{Rmax}$	I_R	<	100				nA
$V_R = V_{Rmax}; T_j = 150 \text{ }^\circ\text{C}$	I_R	<	100				μA
Differential resistance							
$I_F = 10 \text{ mA}$	r_{diff}	typ.	5				Ω
Diode capacitance							
$V_R = 0; f = 1 \text{ MHz}$	C_d	typ.	1,5				pF
		<	5,0				pF
Reverse recovery time when switched from $I_F = 30 \text{ mA}$ to $I_R = 30 \text{ mA};$ $R_L = 100 \text{ } \Omega;$ measured at $I_R = 3 \text{ mA}$	t_{rr}	<	50				ns

1) For sinusoidal operation see Figs 7 to 10. For pulse operation see Figs 3 to 6.

2) At zero life time, measured under pulse conditions to avoid excessive dissipation and voltage limited at 275 V.

Test circuit and waveforms:

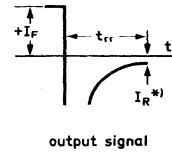
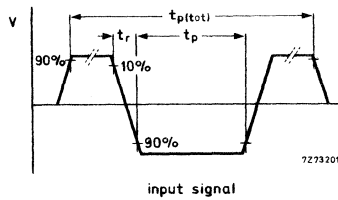
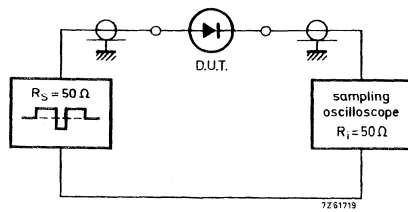

Fig. 2.

*) $I_R = 3 \text{ mA}$

Input signal:	Total pulse duration	$t_p(\text{tot})$	=	$2 \mu\text{s}$
	Duty factor	δ	=	$0,0025$
	Rise time of the reverse pulse	t_r	=	$0,6 \text{ ns}$
	Reverse pulse duration	t_p	=	100 ns
Oscilloscope:	Rise time	t_r	=	$0,35 \text{ ns}$

Circuit capacitance $C \leq 1 \text{ pF}$ ($C = \text{oscilloscope input capacitance} + \text{parasitic capacitance}$)

DEVELOPMENT DATA

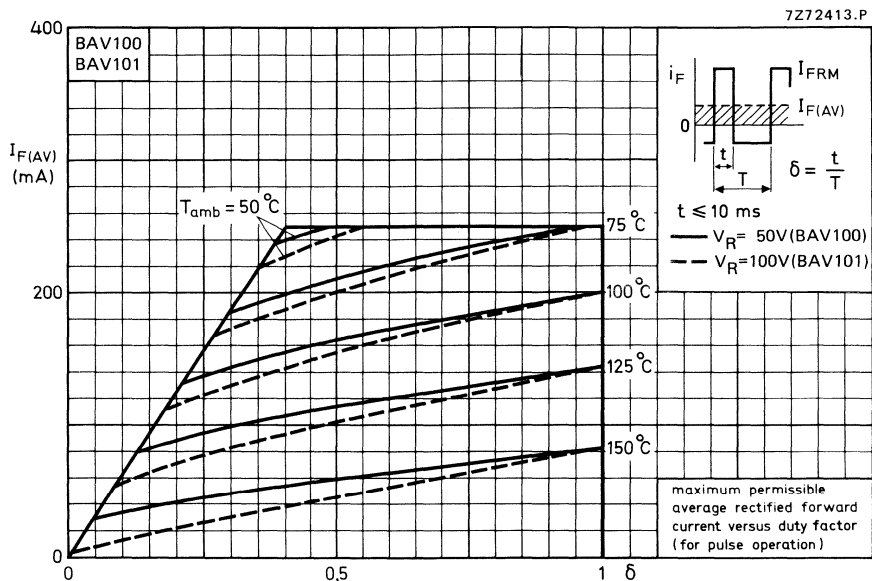

Fig. 3.

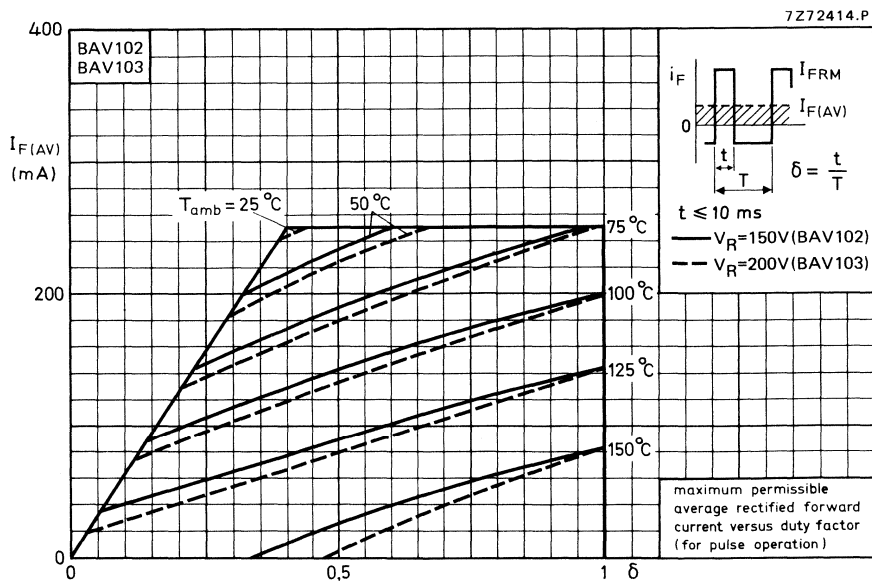

Fig. 4.

DEVELOPMENT DATA

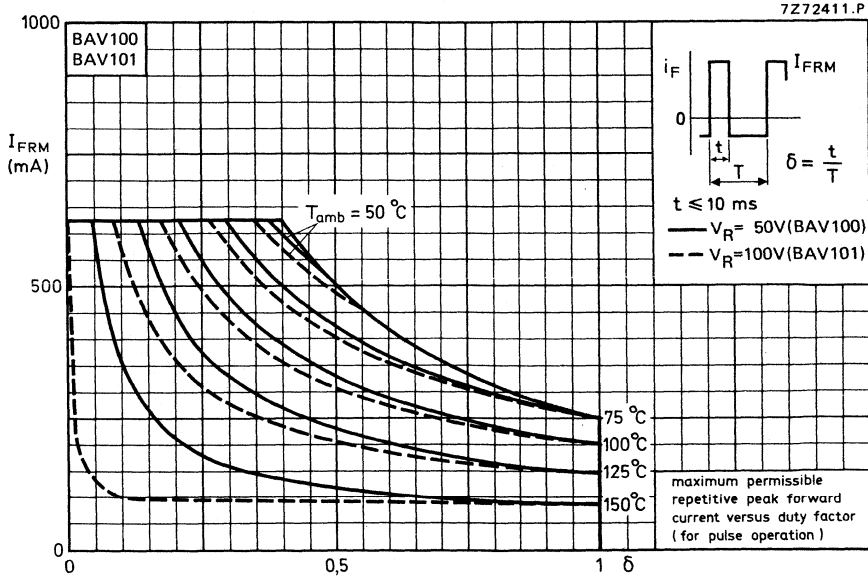

Fig. 5.

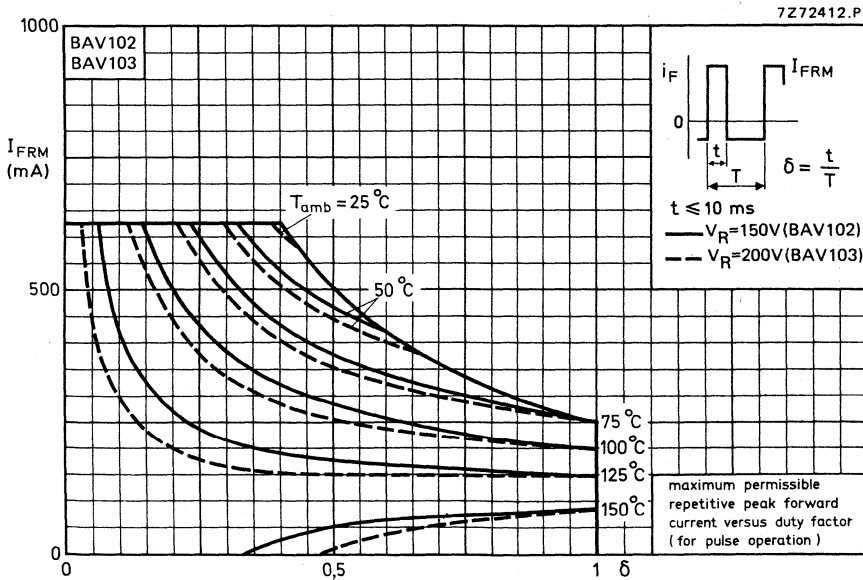

Fig. 6.

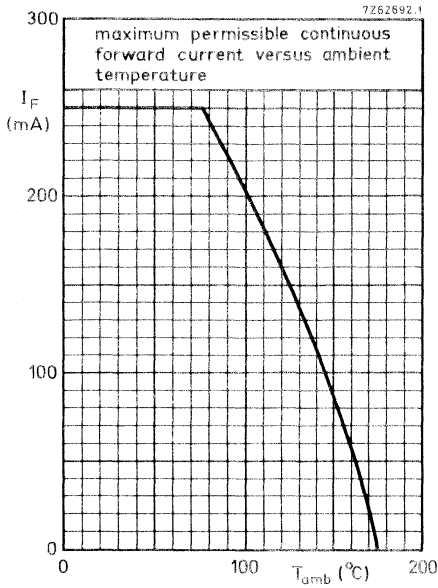

Fig. 7.

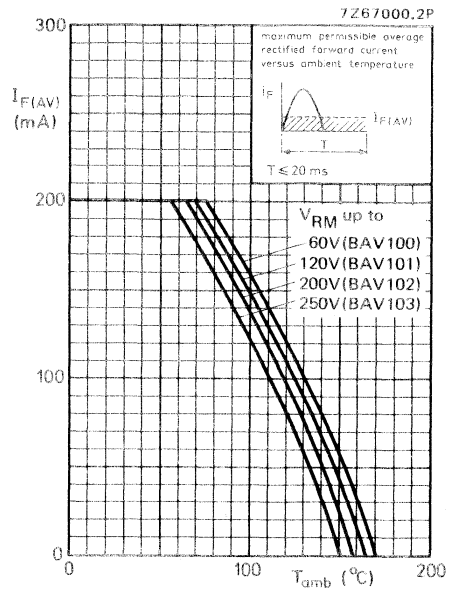

Fig. 8.

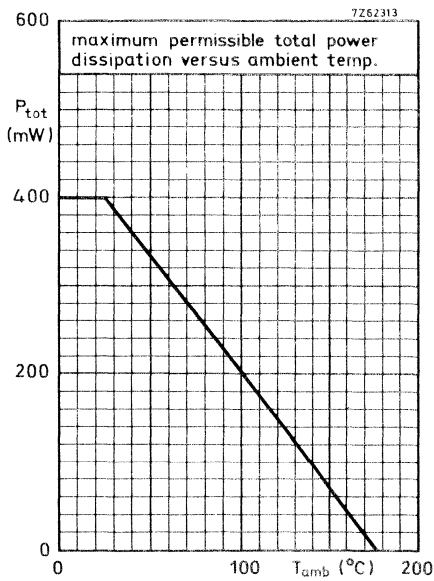

Fig. 9.

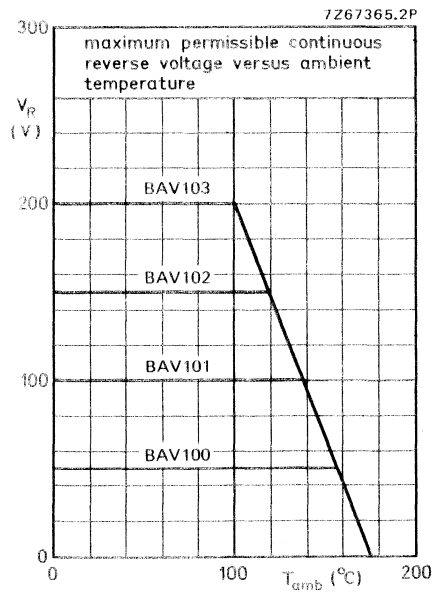

Fig. 10.

DEVELOPMENT DATA

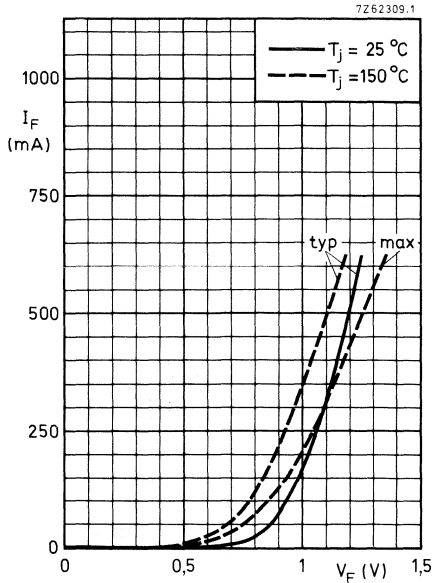

Fig. 11.

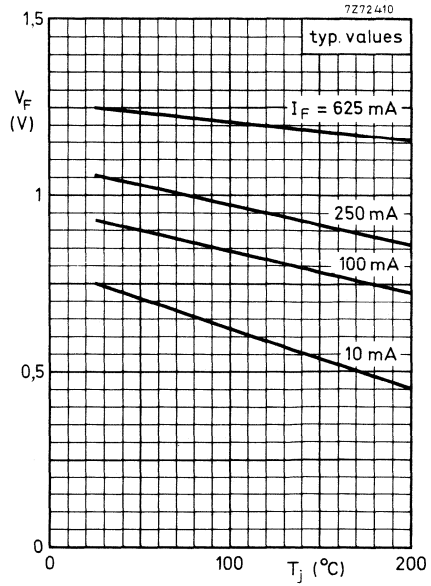

Fig. 12.

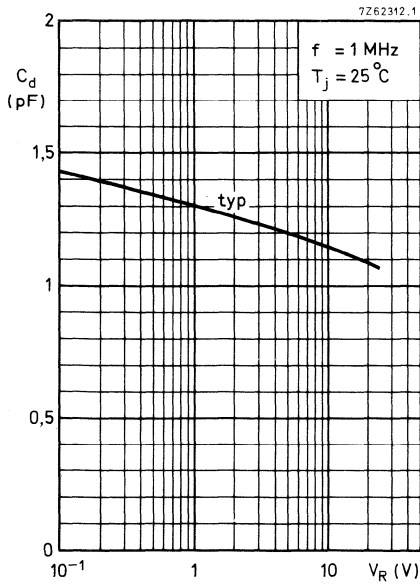

Fig. 13.

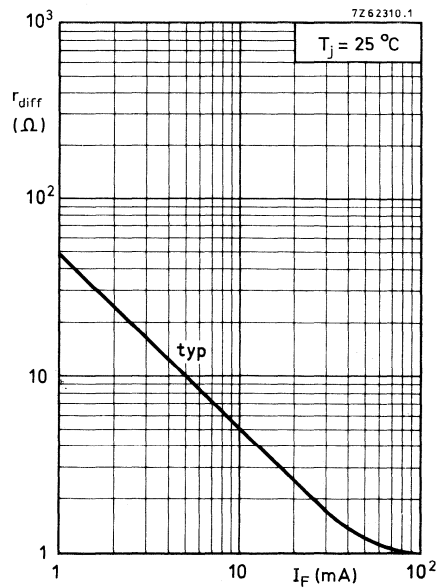

Fig. 14.

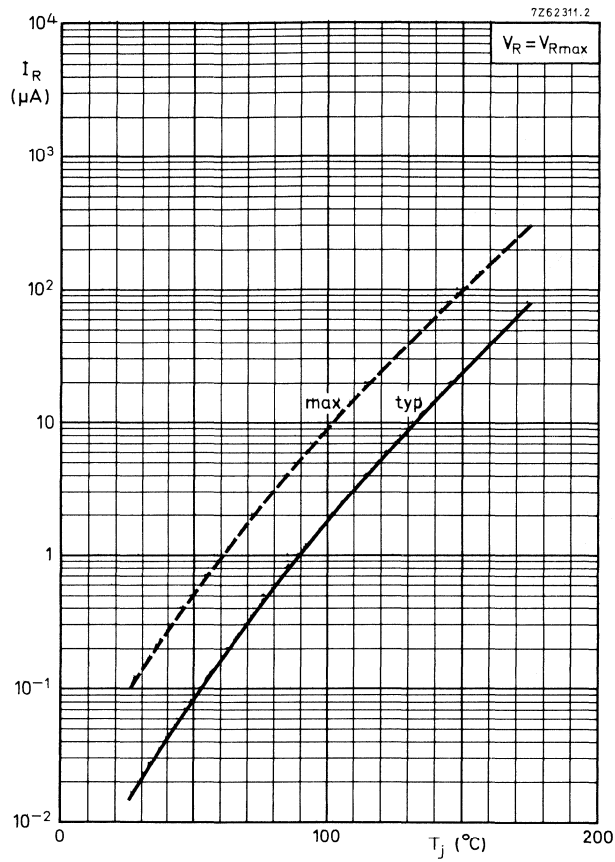

Fig. 15.

SILICON PLANAR EPITAXIAL HIGH-SPEED DIODES

The BAW56 consists of two diodes in a microminiature plastic envelope. The anodes are commoned and the unit is intended for high-speed switching in thick and thin-film circuits.

QUICK REFERENCE DATA (per diode)

Continuous reverse voltage	V_R	max.	70 V
Repetitive peak reverse voltage	V_{RRM}	max.	70 V
Repetitive peak forward current	I_{FRM}	max.	250 mA
Junction temperature	T_j	max.	175 °C
Forward voltage at $I_F = 50$ mA	V_F	<	1,0 V
Reverse recovery time when switched from $I_F = 10$ mA to $I_R = 10$ mA; $R_L = 100 \Omega$; measured at $I_R = 1$ mA	t_{rr}	<	6 ns
Recovery charge when switched from $I_F = 10$ mA to $V_R = 5$ V; $R_L = 500 \Omega$	Q_s	<	45 pC

MECHANICAL DATA

Fig. 1 SOT-23.

Dimensions in mm

Marking code

BAW56 = A1

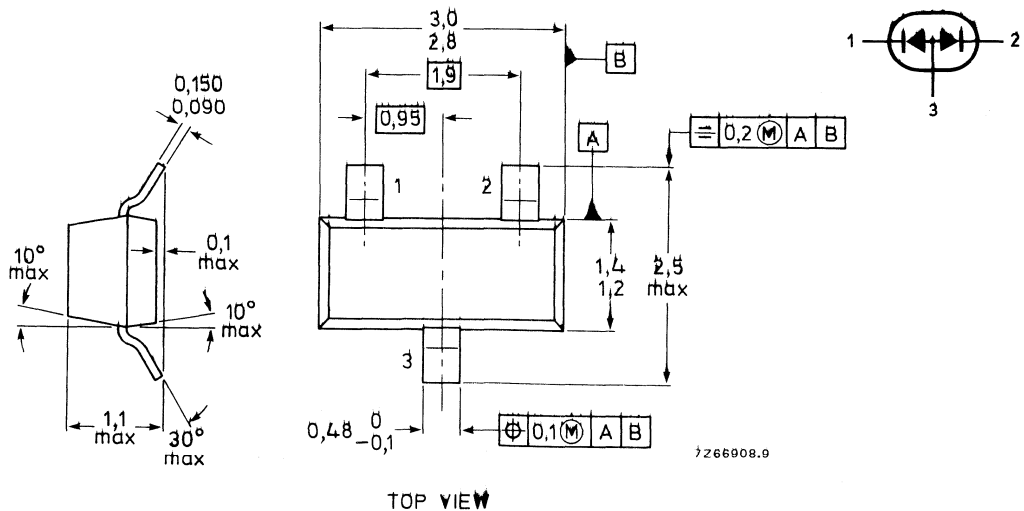

See also *Soldering recommendations*.

RATINGS (per diode)

Limiting values in accordance with the Absolute Maximum System (IEC 134)

Continuous reverse voltage	V_R	max.	70 V
Repetitive peak reverse voltage	V_{RRM}	max.	70 V
Average rectified forward current [▲] (averaged over any 20 ms period)	$I_{F(AV)}$	max.	250 mA
Forward current (d.c.)	I_F	max.	250 mA
Repetitive peak forward current	I_{FRM}	max.	250 mA
→ Non-repetitive peak forward current (per crystal)			
$t = 1 \mu s$	I_{FSM}	max.	2 A
$t = 1 ms$	I_{FSM}	max.	1 A
$t = 1 s$	I_{FSM}	max.	0,5 A
Storage temperature range	T_{stg}		-65 to + 175 °C
Junction temperature	T_j	max.	175 °C

THERMAL RESISTANCE*

From junction to tab	$R_{th j-t}$	=	60 K/W
From tab to soldering points	$R_{th t-s}$	=	2 x 280 K/W
From soldering points to ambient **	$R_{th s-a}$	=	2 x 90 K/W

CHARACTERISTICS (per diode) $T_j = 25 \text{ °C}$ unless otherwise specified

Forward voltage

$I_F = 1 \text{ mA}$	V_F	<	715 mV
$I_F = 10 \text{ mA}$	V_F	<	855 mV
$I_F = 50 \text{ mA}$	V_F	<	1000 mV
$I_F = 150 \text{ mA}$	V_F	<	1250 mV

Reverse current

$V_R = 25 \text{ V}; T_j = 150 \text{ °C}$	I_R	<	30 μA
$V_R = 70 \text{ V}$	I_R	<	2,5 μA
$V_R = 70 \text{ V}; T_j = 150 \text{ °C}$	I_R	<	50 μA

Diode capacitance

$V_R = 0; f = 1 \text{ MHz}$	C_d	<	2 pF
------------------------------	-------	---	------

Forward recovery voltage when switched to

$I_F = 10 \text{ mA}; t_r = 20 \text{ ns}$	V_{fr}	<	1,75 V
--	----------	---	--------

[▲] Measured under pulse conditions: pulse time $t_p \leq 0,5 \text{ ms}$.For sinusoidal operation $I_{F(AV)} = 150 \text{ mA}$; averaging time $t_{(av)} \leq 1 \text{ ms}$.* See *Thermal characteristics*.

** Mounted on a ceramic substrate of 8 mm x 10 mm x 0,7 mm.

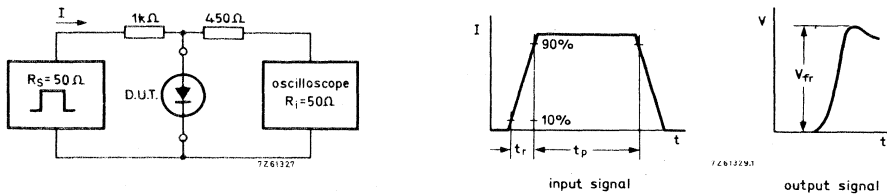

Fig. 2 Test circuit and waveforms; forward recovery voltage.

Input signal: Rise time of the forward pulse $t_r = 20$ ns
 Forward current pulse duration $t_p = 120$ ns. Duty factor $\delta = 0,01$
 Oscilloscope: Rise time $t_r = 0,35$ ns.
 Circuit capacitance $C \leq 1$ pF ($C =$ oscilloscope input capacitance + parasitic capacitance)
 Reverse recovery time when switched from
 $I_F = 10$ mA to $I_R = 10$ mA; $R_L = 100 \Omega$;
 measured at $I_R = 1$ mA

$$t_{rr} < 6 \text{ ns}$$

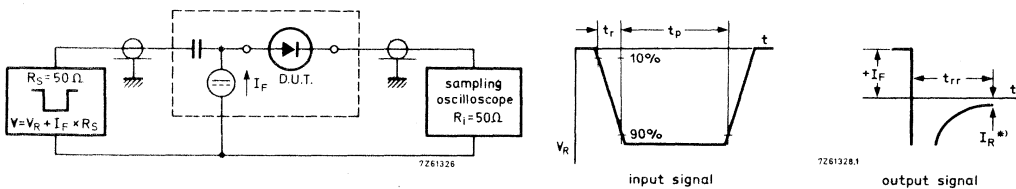

Fig. 3 Test circuit and waveforms; reverse recovery time.

*) $I_R = 1$ mA

Input signal: Rise time of the reverse pulse $t_r = 0,6$ ns
 Reverse pulse duration $t_p = 100$ ns. Duty factor $\delta = 0,05$.
 Oscilloscope: Rise time $t_r = 0,35$ ns
 Circuit capacitance $C \leq 1$ pF ($C =$ oscilloscope input capacitance + parasitic capacitance)
 Recovery charge when switched from
 $I_F = 10$ mA to $V_R = 5$ V; $R_L = 500 \Omega$

$$Q_s < 45 \text{ pC}$$

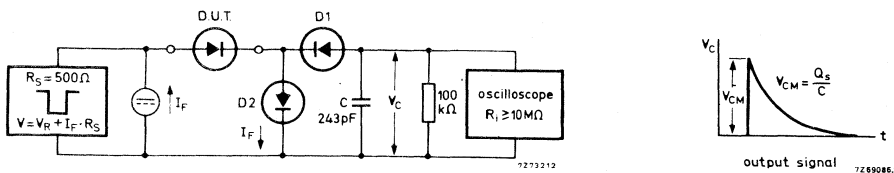

Fig. 4 Test circuit and waveform; recovery charge.

D2 = diode with minority carrier life time at 10 mA: < 200 ps. D1 = BAW62.
 Input signal: Rise time of the reverse pulse $t_r = 2$ ns
 Reverse pulse duration $t_p = 400$ ns. Duty factor $\delta = 0,02$
 Circuit capacitance $C \leq 7$ pF ($C =$ oscilloscope input capacitance + parasitic capacitance).

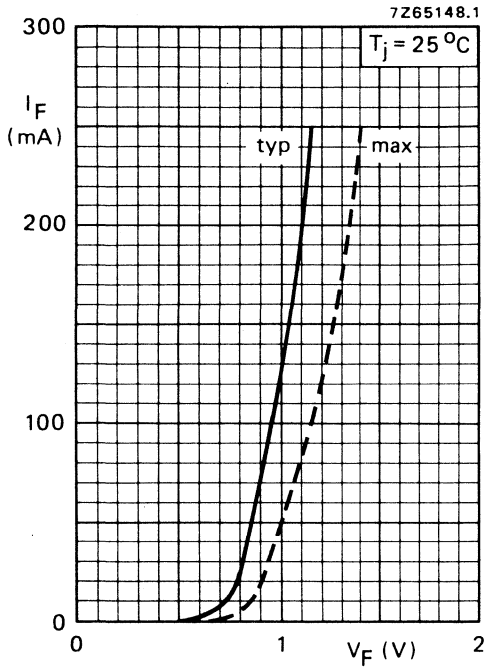

Fig. 5.

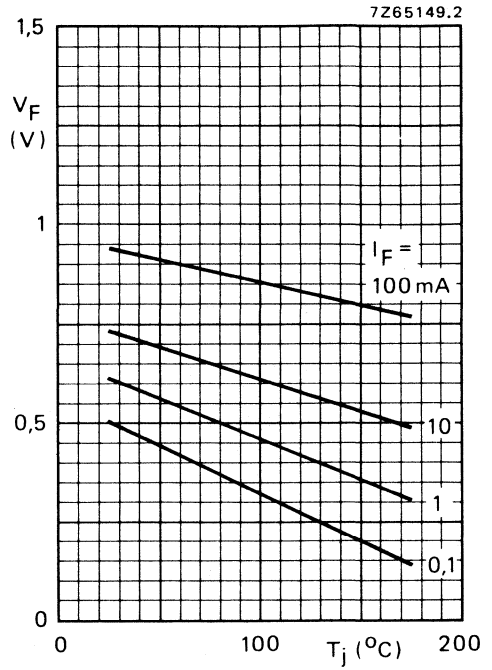

Fig. 6 Typical values.

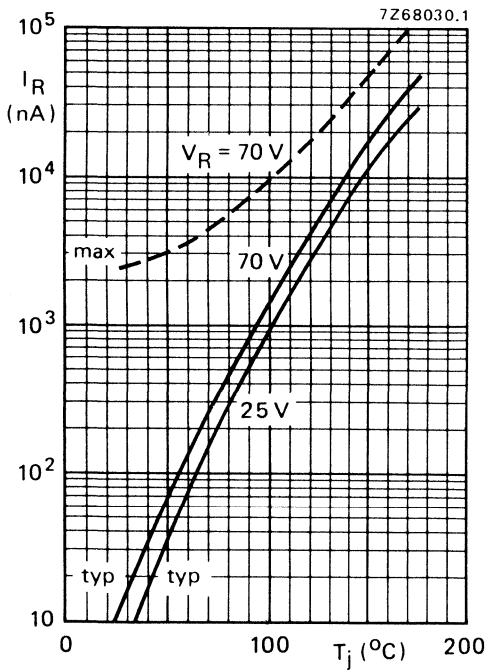

Fig. 7.

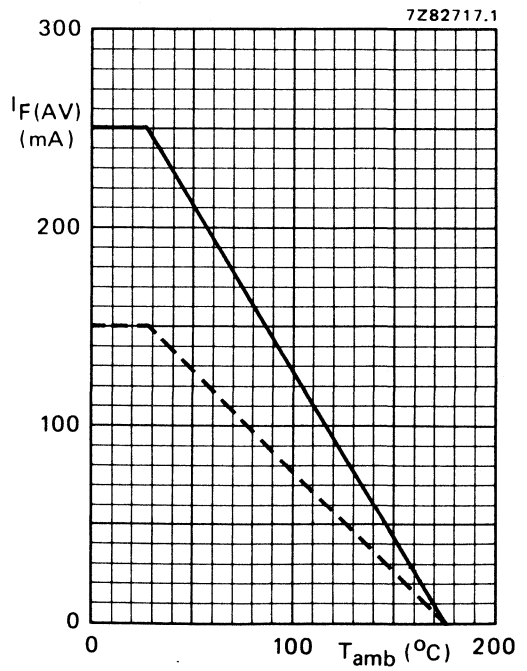

Fig. 8 ——— single diode;
 - - - double diode, equally loaded.

DEVELOPMENT DATA

This data sheet contains advance information and specifications are subject to change without notice.

BB215

U.H.F. VARIABLE CAPACITANCE DIODE

The BB215 is a silicon variable capacitance diode in a hermetically sealed glass envelope (SOD-80) and intended for application in u.h.f. tuners. The leadless SOD-80 encapsulation is intended for surface mounting.

The diode features a capacitance characteristic with a good linearity.

Diodes are supplied in matched sets and the capacitance difference between any two diodes in one set is less than 3% over the voltage range from 0,5 V to 28 V.

QUICK REFERENCE DATA

Continuous reverse voltage	V_R	max.	30 V
Reverse current $V_R = 28$ V	I_R	<	10 nA
Diode capacitance at $f = 500$ kHz $V_R = 28$ V	C_d		1,8 to 2,2 pF
Capacitance ratio at $f = 500$ kHz	$\frac{C_d(V_R = 1 \text{ V})}{C_d(V_R = 28 \text{ V})}$	>	7,6
Series resistance at $f = 470$ MHz V_R is that value at which $C_d = 9$ pF	r_s	typ.	0,63 Ω

MECHANICAL DATA

Dimensions in mm

Fig. 1 SOD-80.

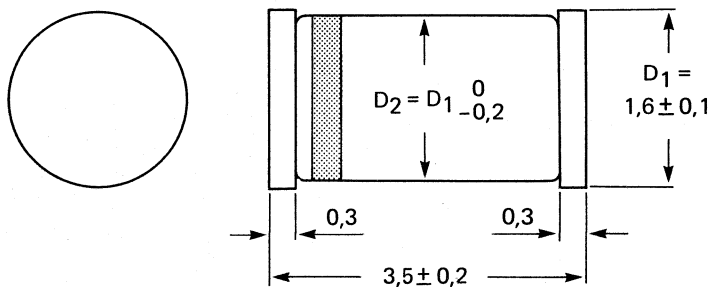

The cathode is indicated by a white band on the body and a second green band indicates the BB215 type.

RATINGS

Limiting values in accordance with the Absolute Maximum System (IEC 134)

Continuous reverse voltage	V_R	max.	30 V
Forward current (d.c.)	I_F	max.	20 mA
Storage temperature	T_{stg}		-55 to +150 °C
Operating junction temperature	T_j	max.	100 °C

CHARACTERISTICS

$T_{amb} = 25\text{ °C}$ unless otherwise specified

Reverse current

$V_R = 28\text{ V}$	I_R	<	10 nA
$V_R = 28\text{ V}; T_{amb} = 85\text{ °C}$			200 nA

Diode capacitance at $f = 500\text{ kHz}$

$V_R = 1\text{ V}$	C_d	typ.	17 pF
			<
$V_R = 3\text{ V}$	C_d	typ.	11 pF
$V_R = 28\text{ V}$	C_d		1,8 to 2,2 pF

Capacitance ratio at $f = 500\text{ kHz}$

$\frac{C_d(V_R = 1\text{ V})}{C_d(V_R = 28\text{ V})}$	>	7,6
	typ.	8,3

Series resistance

at $f = 470\text{ MHz}$ and at that value of V_R at which $C_d = 9\text{ pF}$

r_s	typ.	0,63 Ω
-------	------	---------------

DEVELOPMENT DATA

This data sheet contains advance information and specifications are subject to change without notice.

BB219

V.H.F. VARIABLE CAPACITANCE DIODE

The BB219 is a silicon variable capacitance diode in a hermetically sealed glass envelope (SOD-80) and intended for electronic tuning in v.h.f. television tuners for C.A.T.V. applications. The SOD-80 envelope is suitable for surface mounting.

QUICK REFERENCE DATA

Reverse voltage, peak value	V_{RM}	max.	30 V
Reverse current $V_R = 28$ V	I_R	<	10 nA
Diode capacitance at $f = 1$ MHz $V_R = 1$ V $V_R = 28$ V	C_d	>	31 pF 2,6 to 3,2 pF
Capacitance ratio at $f = 1$ MHz	$\frac{C_d(V_R = 1 \text{ V})}{C_d(V_R = 28 \text{ V})}$		12 to 15
Series resistance at $f = 100$ MHz V_R is that value at which $C_d = 30$ pF	r_s	typ. <	0,7 Ω 0,9 Ω

MECHANICAL DATA

Dimensions in mm

Fig. 1 SOD-80.

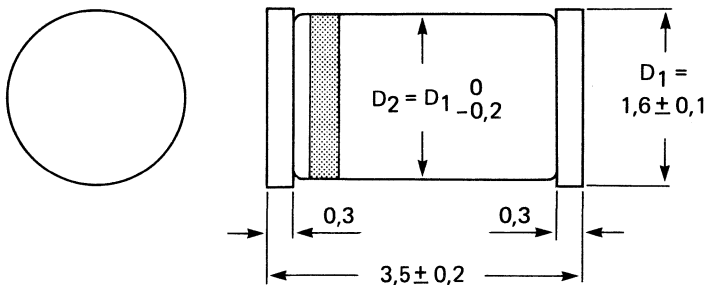

7Z91084.1

RATINGS

Limiting values in accordance with the Absolute Maximum System (IEC 134)

Reverse voltage, peak value	V_{RM}	max.	30 V	←
Forward current (d.c.)	I_F	max.	20 mA	
Storage temperature	T_{stg}		-55 to +150 °C	
Operating junction temperature	T_j	max.	100 °C	

THERMAL RESISTANCE

From junction to ambient in free air	$R_{th\ j-a}$	=	0,6 K/mW
--------------------------------------	---------------	---	----------

CHARACTERISTICS

$T_{amb} = 25\text{ °C}$ unless otherwise specified

Reverse current

$V_R = 28\text{ V}$

$V_R = 28\text{ V}; T_{amb} = 85\text{ °C}$

I_R	<	10 nA
	<	200 nA

Diode capacitance at $f = 0,5\text{ MHz}$

$V_R = 1\text{ V}$

$V_R = 3\text{ V}$

$V_R = 28\text{ V}$

C_d	>	31 pF
C_d	typ.	24 pF
C_d		2,6 to 3,2 pF

Capacitance ratio at $f = 1\text{ MHz}$

$$\frac{C_d(V_R = 1\text{ V})}{C_d(V_R = 28\text{ V})} \quad 12\text{ to }15$$

Series resistance

at $f = 100\text{ MHz}$ and at that value
of V_R at which $C_d = 30\text{ pF}$

r_s	typ.	0,7 Ω
	<	0,9 Ω

Tolerance of capacitance difference

between two diodes at $V_R = 1\text{ to }28\text{ V}$

$$\frac{\Delta C}{C} \quad < \quad 2,5\%$$

VARIABLE CAPACITANCE DIODE

Silicon planar variable capacitance diode in a microminiature envelope. It is intended for electronic tuning applications in thick and thin-film circuits.

QUICK REFERENCE DATA

Reverse voltage	V_R	max.	28 V
Reverse current at $V_R = 28$ V	I_R	<	50 nA
Diode capacitance at $f = 1$ MHz $V_R = 25$ V	C_d		1,8 to 2,8 pF
Capacitance ratio at $f = 1$ MHz	$\frac{C_d (V_R = 3 \text{ V})}{C_d (V_R = 25 \text{ V})}$	typ.	5
Series resistance at $f = 470$ MHz $V_R =$ that value at which $C_d = 9$ pF	r_D	<	1,2 Ω

MECHANICAL DATA

Fig. 1 SOT-23.

Dimensions in mm

Marking code

BBY31 = S1

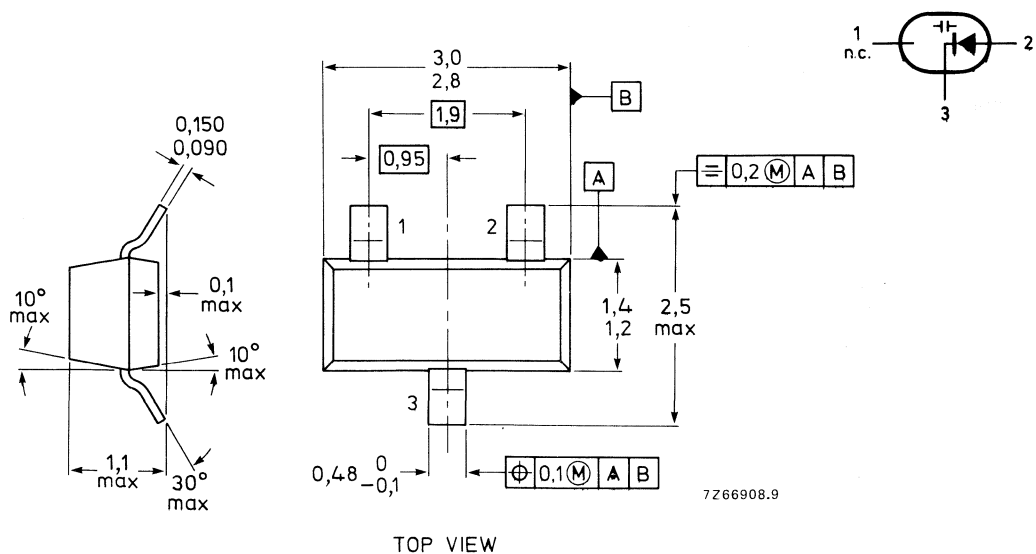

See also *Soldering recommendations*.

RATINGS

Limiting values in accordance with the Absolute Maximum System (IEC 134)

Continuous reverse voltage	V_R	max.	28 V
Reverse voltage (peak value)	V_{RM}	max.	30 V
Forward current (d.c.)**	I_F	max.	20 mA
Storage temperature	T_{stg}		-65 to + 100 °C
Operating junction temperature	T_j	max.	85 °C

THERMAL RESISTANCE

→ From junction to ambient*	$R_{th\ j-a}$	=	430 K/W
-----------------------------	---------------	---	---------

CHARACTERISTICS

$T_j = 25\text{ °C}$ unless otherwise specified

Reverse current

$V_R = 28\text{ V}$	I_R	<	50 nA
---------------------	-------	---	-------

$V_R = 28\text{ V}; T_j = 85\text{ °C}$	I_R	<	1000 nA
---	-------	---	---------

Diode capacitance at $f = 1\text{ MHz}$

$V_R = 1\text{ V}$	C_d	typ.	17,5 pF
--------------------	-------	------	---------

$V_R = 3\text{ V}$	C_d	typ.	11,5 pF
--------------------	-------	------	---------

$V_R = 25\text{ V}$	C_d		1,8 to 2,8 pF
---------------------	-------	--	---------------

Capacitance ratio at $f = 1\text{ MHz}$

$\frac{C_d(V_R = 3\text{ V})}{C_d(V_R = 25\text{ V})}$	typ.	5
--	------	---

Series resistance at $f = 470\text{ MHz}$

and at that value of V_R at which $C_d = 9\text{ pF}$	r_D	<	1,2 Ω
---	-------	---	--------------

* Mounted on a ceramic substrate of 7 mm x 5 mm x 0,5 mm.

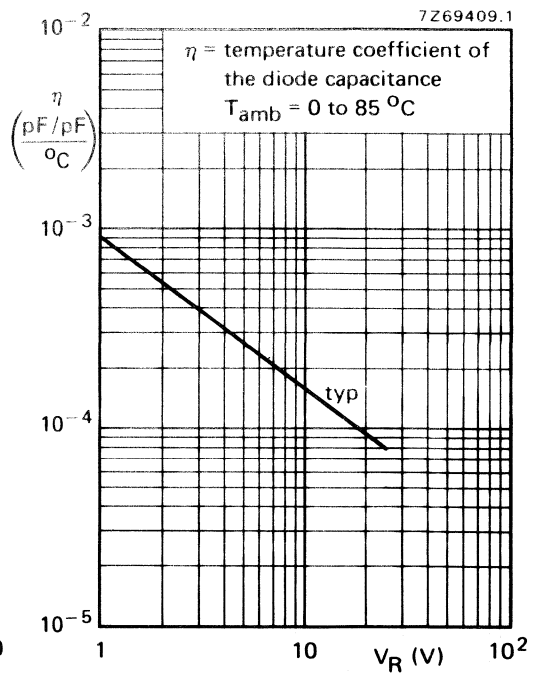
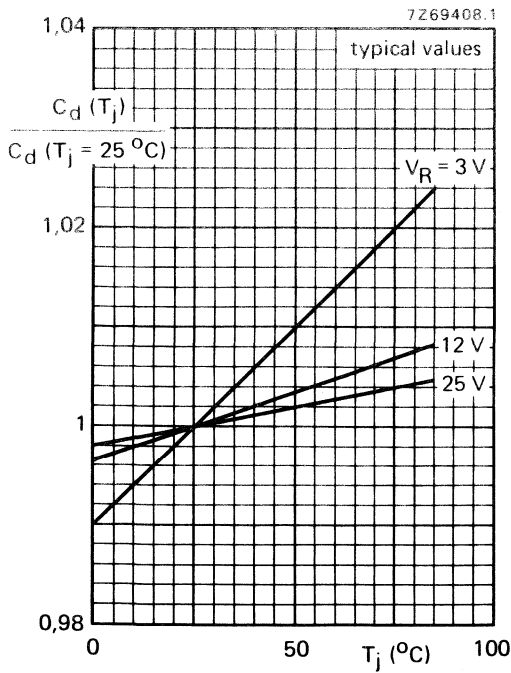
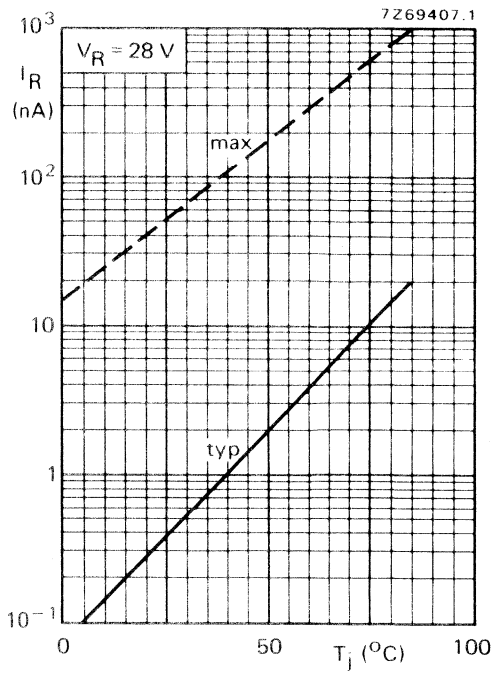
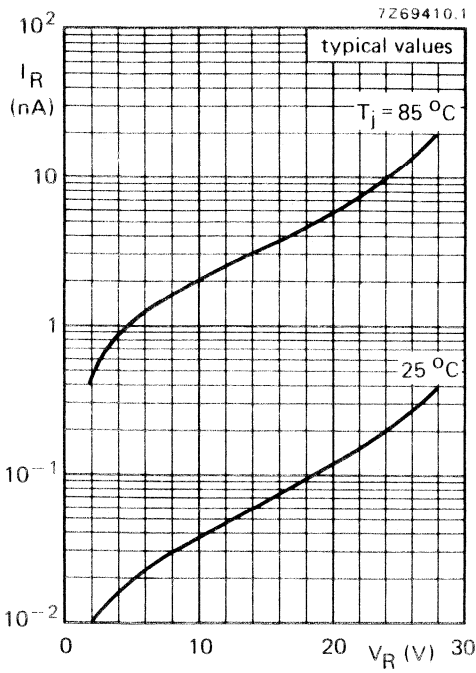

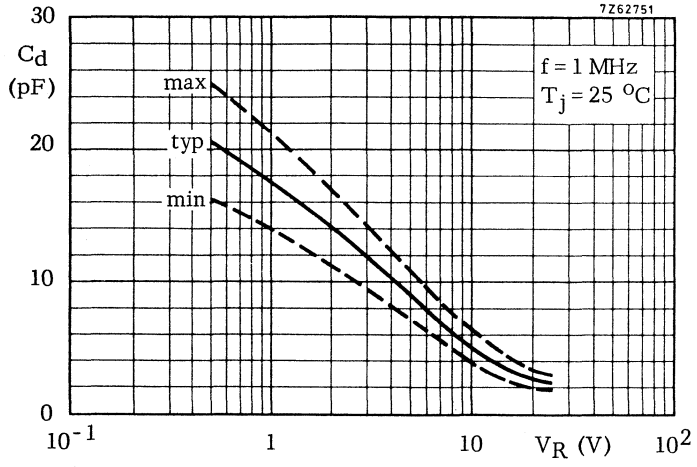

SILICON PLANAR VARIABLE CAPACITANCE DIODE

The BBY40 is a variable capacitance diode in a plastic envelope intended for electronic tuning in v.h.f. television tuners with extended band I (FCC and OIRT-norm).

QUICK REFERENCE DATA

Continuous reverse voltage	V_R	max.	28 V
Reverse current at $V_R = 28$ V	I_R	<	50 nA
Diode capacitance at $f = 1$ MHz	C_d		26 to 32 pF
$V_R = 3$ V	C_d		4,3 to 6 pF
$V_R = 25$ V	C_d		5 to 6,5
Capacitance ratio at $f = 1$ MHz	$\frac{C_d(V_R = 3\text{ V})}{C_d(V_R = 25\text{ V})}$		5 to 6,5
Series resistance at $f = 200$ MHz	r_D	<	0,6 Ω
V_R is that value at which $C_d = 25$ pF			

MECHANICAL DATA

Dimensions in mm

Marking code

Fig. 1 SOT-23.

BBY40 = S2

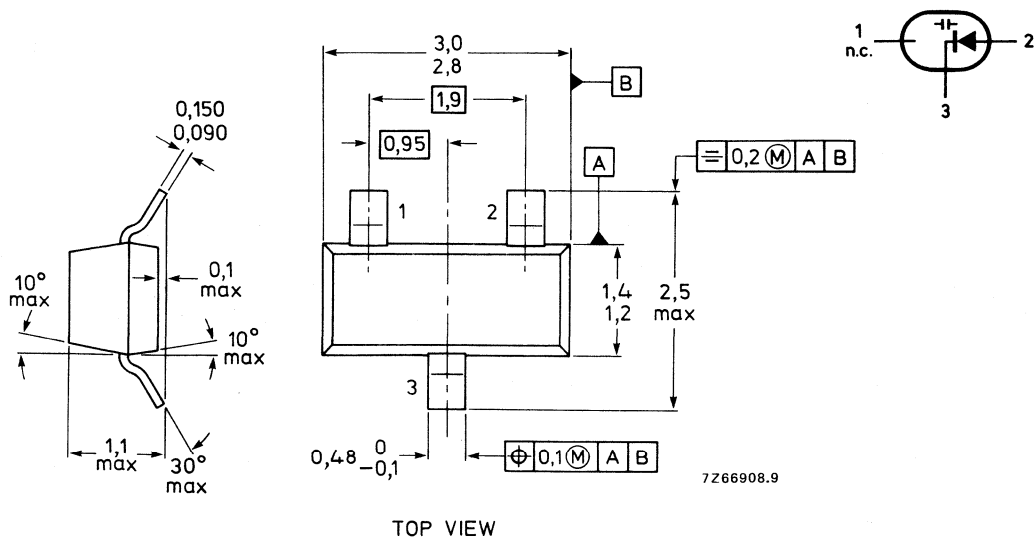

See also *Soldering recommendations.*

RATINGS

Limiting values in accordance with the Absolute Maximum System (IEC 134)

Continuous reverse voltage	V_R	max.	28 V
Reverse voltage (repetitive peak value)	V_{RRM}	max.	30 V
Forward current (d.c.)	I_F	max.	20 mA
Storage temperature	T_{stg}		-55 to + 100 °C
Operating junction temperature	T_j	max.	85 °C

THERMAL RESISTANCE

From junction to ambient*	$R_{th\ j-a}$	=	430 K/W
---------------------------	---------------	---	---------

CHARACTERISTICS

$T_{amb} = 25\text{ °C}$ unless otherwise specified

Reverse current

$$V_R = 28\text{ V}$$

I_R	typ.	0,1 nA
	<	50 nA

$$V_R = 28\text{ V}; T_{amb} = 60\text{ °C}$$

I_R	<	500 nA
-------	---	--------

Diode capacitance at $f = 1\text{ MHz}$

$$V_R = 3\text{ V}$$

C_d	26 to 32 pF
-------	-------------

$$V_R = 25\text{ V}$$

C_d	4,3 to 6 pF
-------	-------------

Capacitance ratio at $f = 1\text{ MHz}$

$\frac{C_d(V_R = 3\text{ V})}{C_d(V_R = 25\text{ V})}$	5 to 6,5
--	----------

Series resistance at $f = 200\text{ MHz}$

V_R is that value at which $C_d = 25\text{ pF}$

r_D	typ.	0,4 Ω
	<	0,6 Ω

* Mounted on a ceramic substrate of 7 mm x 5 mm x 0,5 mm.

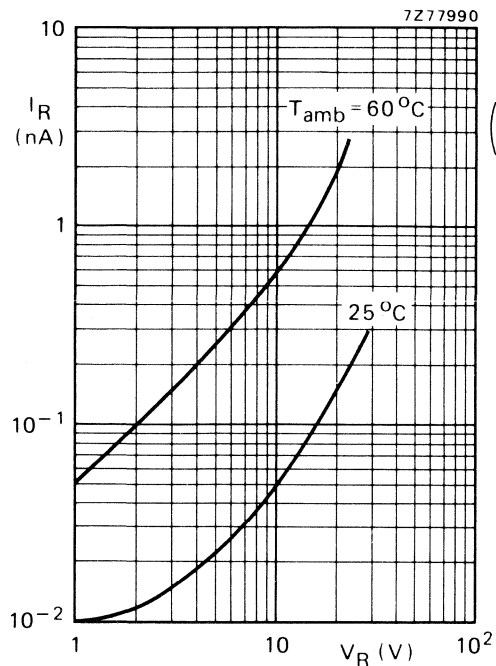

Fig. 2 Typical values

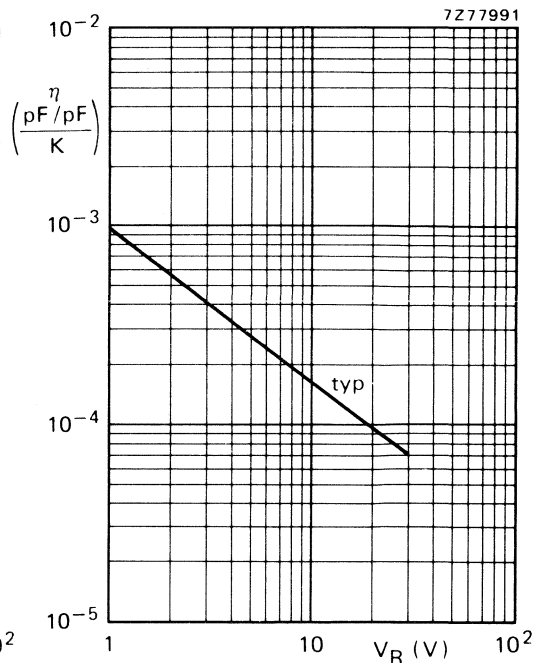

Fig. 3 Temperature coefficient of the diode capacitance; $T_{amb} = 0$ to 85°C .

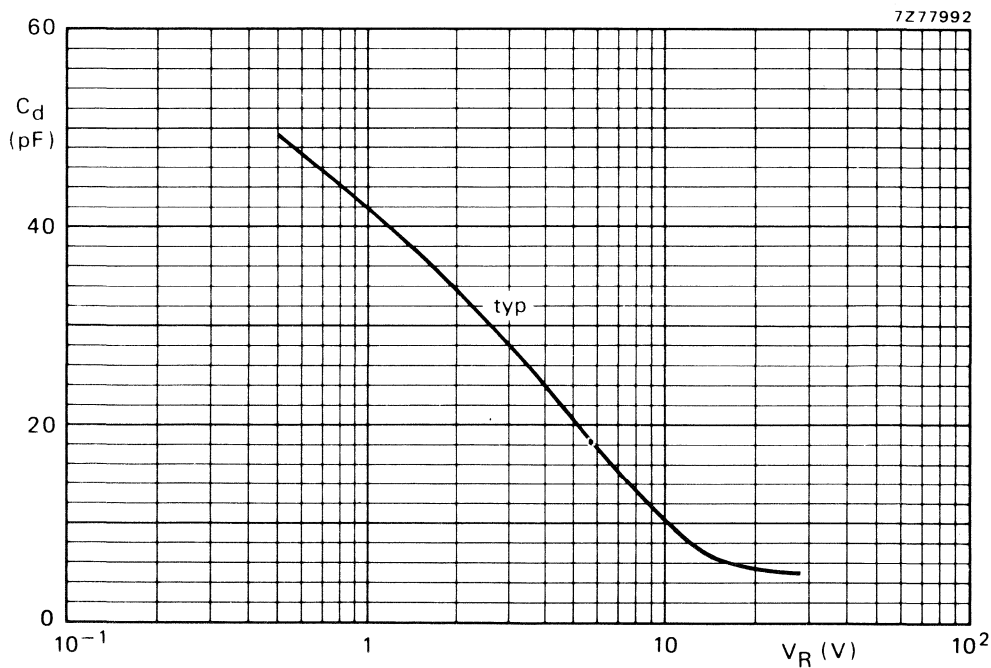

Fig. 4 $f = 1$ MHz; $T_{amb} = 25^\circ\text{C}$.

SILICON PLANAR EPITAXIAL TRANSISTORS

P-N-P transistors, in a SOT-23 plastic envelope for use in driver and output stages of audio amplifiers in thick and thin-film hybrid circuits.

N-P-N complements are BC817; R and BC818; R respectively.

QUICK REFERENCE DATA

		BC807	BC808
Collector-emitter voltage ($V_{BE} = 0$)	$-V_{CES}$ max.	50	30 V
Collector-emitter voltage (open base)	$-V_{CEO}$ max.	45	25 V
Collector current (peak value)	$-I_{CM}$ max.	1000	mA
Total power dissipation up to $T_{amb} = 35^\circ\text{C}$	P_{tot} max.	310	mW
Junction temperature	T_j max.	150	$^\circ\text{C}$
Transition frequency at $f = 35\text{ MHz}$ $-I_C = 10\text{ mA}; -V_{CE} = 5\text{ V}$	f_T typ.	100	MHz

MECHANICAL DATA

Fig. 1 SOT-23.

Dimensions in mm

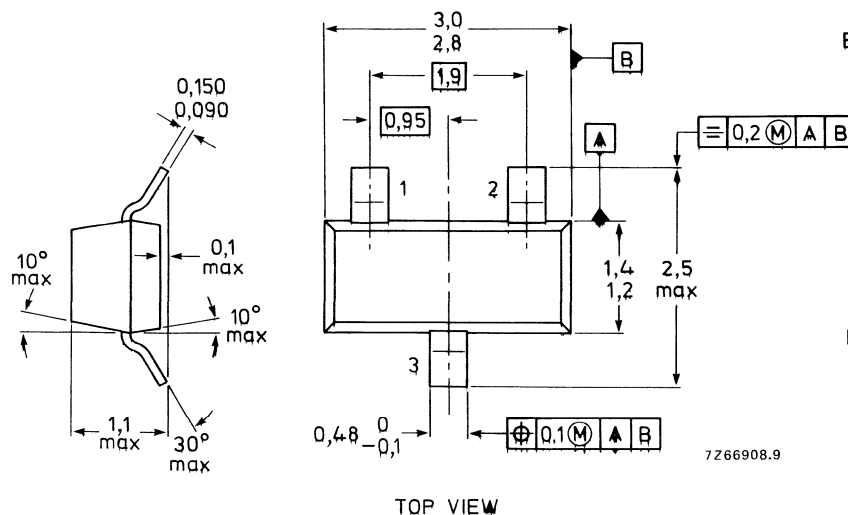

Marking code

BC807-16 = 5 A
-25 = 5 B
-40 = 5 C
BC808-16 = 5 E
-25 = 5 F
-40 = 5 G

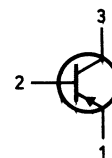

BC807-16R = 5 AR
-25R = 5 BR
-40R = 5 CR
BC808-16R = 5 ER
-25R = 5 FR
-40R = 5 GR

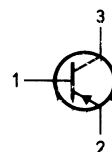

R-types are available on request.

RATINGS

Limiting values in accordance with the Absolute Maximum System (IEC 134)

		BC807	BC808
Collector-emitter voltage ($V_{BE} = 0$)	$-V_{CES}$	max. 50	30 V
Collector-emitter voltage (open base) $-I_C = 10$ mA	$-V_{CEO}$	max. 45	25 V
Emitter-base voltage (open collector)	$-V_{EBO}$	max. 5	5 V
Collector current (d.c.)	$-I_C$	max. 500	mA
Collector current (peak value)	$-I_{CM}$	max. 1000	mA
Emitter current (peak value)	I_{EM}	max. 1000	mA
Base current (d.c.)	$-I_B$	max. 100	mA
Base current (peak value)	$-I_{BM}$	max. 200	mA
Total power dissipation at $T_{amb} = 35$ °C *	P_{tot}	max. 310	mW
Storage temperature	T_{stg}	-65 to +150	°C
Junction temperature	T_j	max. 150	°C

THERMAL CHARACTERISTICS **

$$T_j = P (R_{th j-t} + R_{th t-s} + R_{th s-a}) + T_{amb}$$

Thermal resistance

From junction to tab	$R_{th j-t}$	=	50	K/W
From tab to soldering points	$R_{th t-s}$	=	260	K/W
From soldering points to ambient *	$R_{th s-a}$	=	60	K/W

* Mounted on a ceramic substrate of 15 mm x 15 mm x 0,7 mm.

** See *Thermal characteristics*.

CHARACTERISTICS

$T_j = 25\text{ }^\circ\text{C}$ unless otherwise specified

Collector cut-off current

$I_E = 0; -V_{CB} = 20\text{ V}; T_j = 25\text{ }^\circ\text{C}$

$-I_{CBO} < 100\text{ nA}$

$I_E = 0; -V_{CB} = 20\text{ V}; T_j = 150\text{ }^\circ\text{C}$

$-I_{CBO} < 5\text{ }\mu\text{A}$

Emitter cut-off current

$I_C = 0; V_{EB} = 5\text{ V}$

$-I_{EBO} < 10\text{ }\mu\text{A}$

Base emitter voltage *

$-I_C = 500\text{ mA}; -V_{CE} = 1\text{ V}$

$-V_{BE} < 1,2\text{ V}$

Saturation voltage

$-I_C = 500\text{ mA}; -I_B = 50\text{ mA}$

$-V_{CEsat} < 700\text{ mV}$

D.C. current gain

$-I_C = 500\text{ mA}; -V_{CE} = 1\text{ V}$

$h_{FE} > 40$

$-I_C = 100\text{ mA}; -V_{CE} = 1\text{ V}; \text{BC807; BC808}$

$h_{FE} 100\text{ to }600$

BC807-16 }
BC808-16 }

$h_{FE} 100\text{ to }250$

BC807-25 }
BC808-25 }

$h_{FE} 160\text{ to }400$

BC807-40 }
BC808-40 }

$h_{FE} 250\text{ to }600$

Transition frequency at $f = 35\text{ MHz}$

$-I_C = 10\text{ mA}; -V_{CE} = 5\text{ V}$

$f_T \text{ typ. } 100\text{ MHz}$

Collector capacitance at $f = 1\text{ MHz}$

$I_E = I_e = 0; -V_{CB} = 10\text{ V}$

$C_c \text{ typ. } 8\text{ pF}$

* $-V_{BE}$ decreases by about 2 mV/K with increasing temperature.

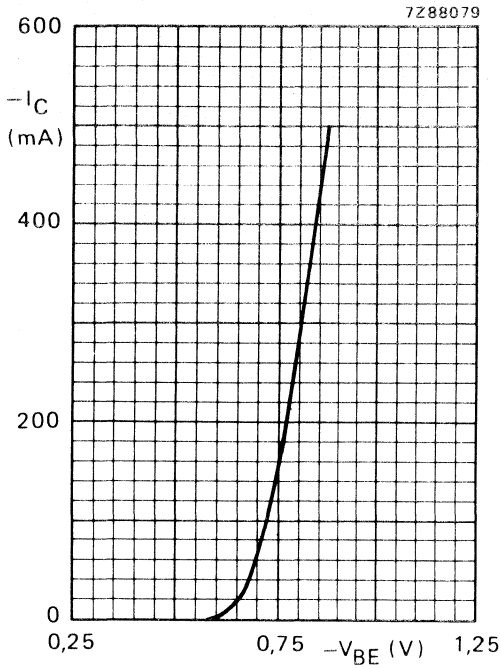

Fig. 2 $-V_{CE} = 1$ V; $T_j = 25$ °C.
Typical values.

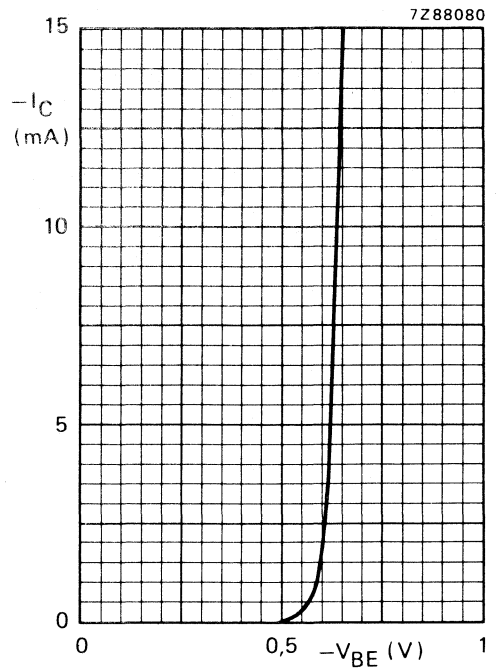

Fig. 3 $-V_{CE} = 5$ V; $T_j = 25$ °C.
Typical values.

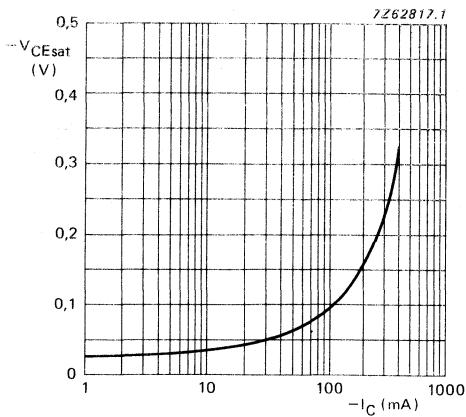

Fig. 4 typical values.

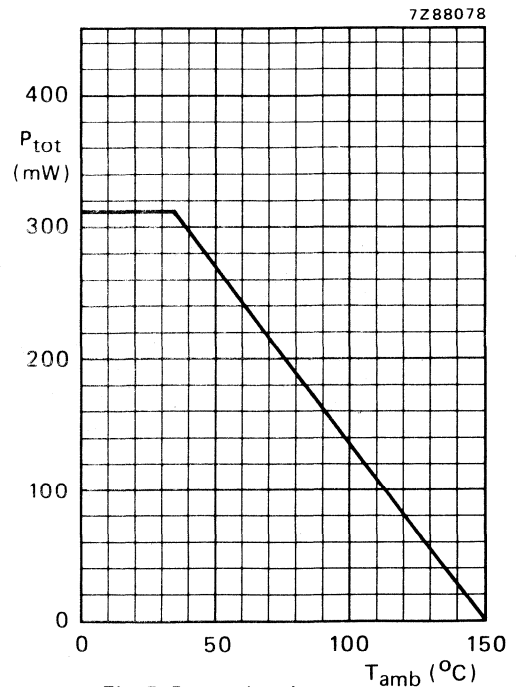

Fig. 5. Power derating curve.

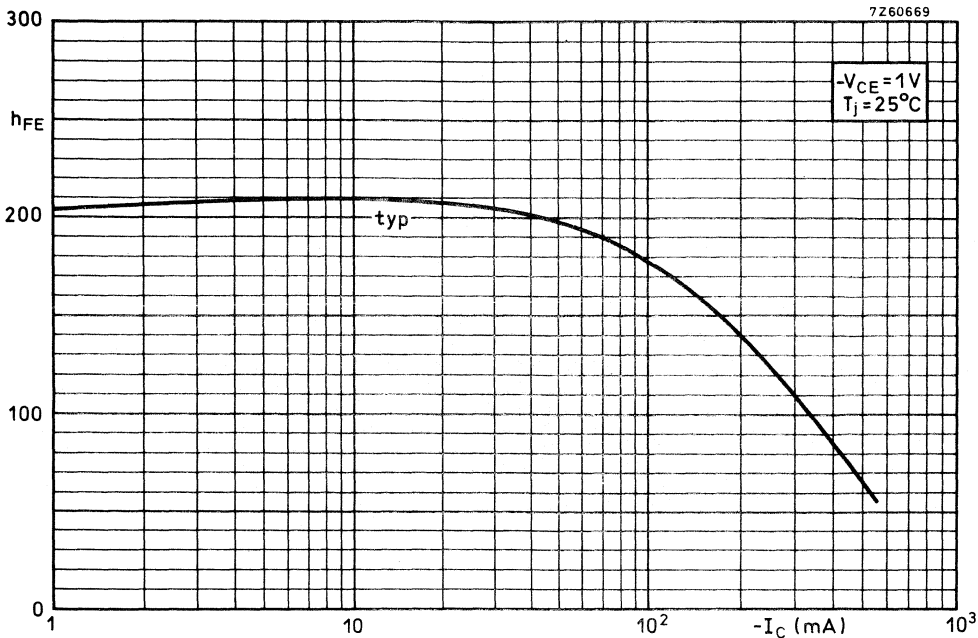

Fig. 6 D.C. current gain.

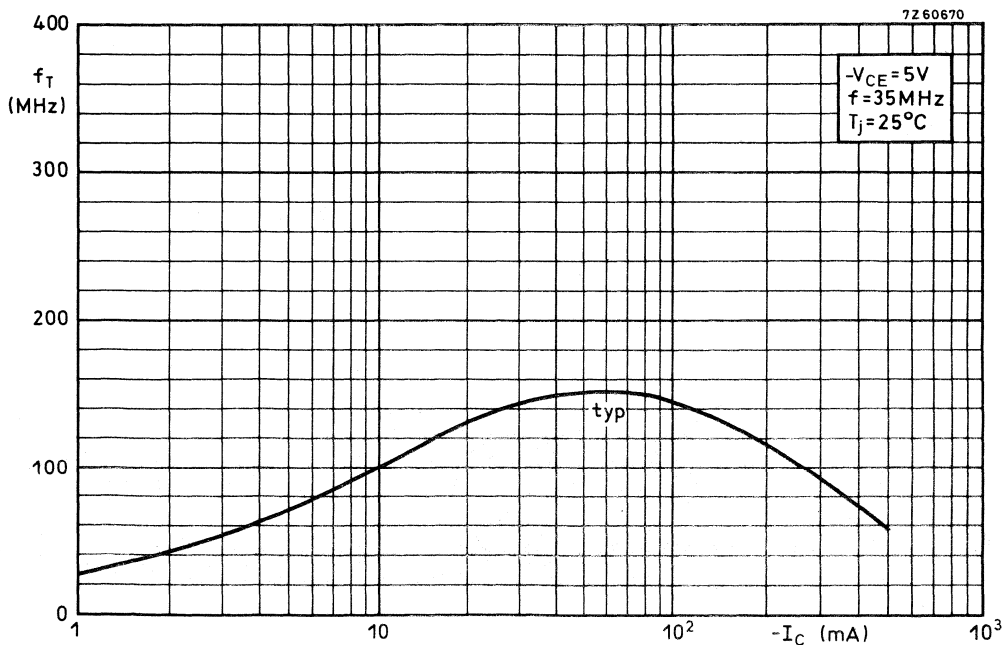

Fig. 7 Typical values transition frequency.

SILICON PLANAR EPITAXIAL TRANSISTORS

N-P-N transistors, in a SOT-23 plastic envelope for use in driver and output stages of audio amplifiers in thick and thin-film hybrid circuits.

P-N-P complements are BC807; R and BC808; R respectively.

QUICK REFERENCE DATA

		BC817	BC818
Collector-emitter voltage ($V_{BE} = 0$)	V_{CES}	max. 50	30 V
Collector-emitter voltage (open base)	V_{CEO}	max. 45	25 V
Collector current (peak value)	I_{CM}	max. 1000	mA
Total power dissipation up to $T_{amb} = 35\text{ }^{\circ}\text{C}$	P_{tot}	max. 310	mW
Junction temperature	T_j	max. 150	$^{\circ}\text{C}$
Transition frequency at $f = 35\text{ MHz}$ $I_C = 10\text{ mA}; V_{CE} = 5\text{ V}$	f_T	typ. 200	MHz

MECHANICAL DATA

Dimensions in mm

Marking code

Fig. 1 SOT-23.

BC817-16 = 6 A
-25 = 6 B
-40 = 6 C
BC818-16 = 6 E
-25 = 6 F
-40 = 6 G

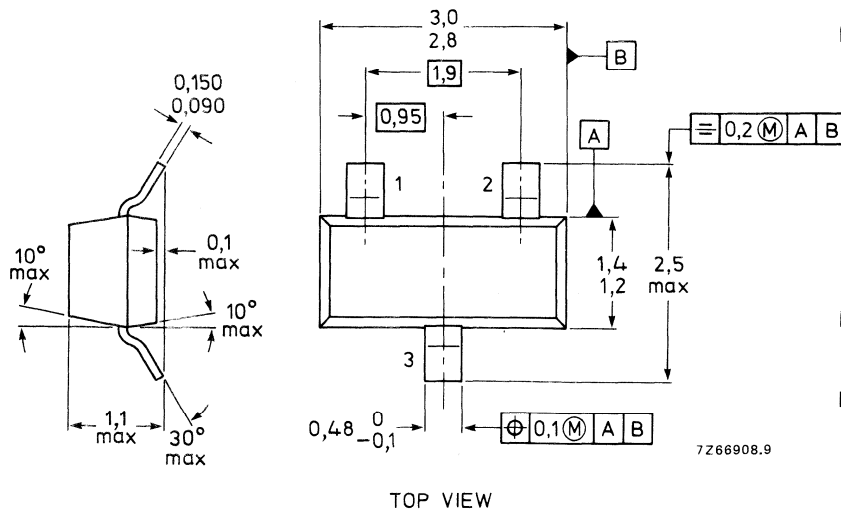

BC817-16R = 6 AR
-25R = 6 BR
-40R = 6 CR
BC818-16R = 6 ER
-25R = 6 FR
-40R = 6 GR

R-types are available on request.

See also *Soldering recommendations*.

RATINGS

Limiting values in accordance with the Absolute Maximum System (IEC 134)

			BC817	BC818
Collector-emitter voltage ($V_{BE} = 0$)	V_{CES}	max.	50	30 V
Collector-emitter voltage (open base) $I_C = 10 \text{ mA}$	V_{CEO}	max.	45	25 V
Emitter-base voltage (open collector)	V_{EBO}	max.	5	5 V
Collector current (d.c.)	I_C	max.	500	mA
Collector current (peak value)	I_{CM}	max.	1000	mA
Emitter current (peak value)	$-I_{EM}$	max.	1000	mA
Base current (d.c.)	I_B	max.	100	mA
Base current (peak value)	I_{BM}	max.	200	mA
Total power dissipation up to $T_{amb} = 35 \text{ }^\circ\text{C}$	P_{tot}	max.	310	mW
Storage temperature	T_{stg}		-65 to +150	$^\circ\text{C}$
Junction temperature	T_j	max.	150	$^\circ\text{C}$

THERMAL CHARACTERISTICS **

$$T_j = P (R_{th j-t} + R_{th t-s} + R_{th s-a}) + T_{amb}$$

Thermal resistance

From junction to tab	$R_{th j-t}$	=	50	K/W
From tab to soldering points	$R_{th t-s}$	=	260	K/W
From soldering points to ambient *	$R_{th s-a}$	=	60	K/W

* Mounted on a ceramic substrate of 15 mm x 15 mm x 0,7 mm.

** See *Thermal characteristics*.

CHARACTERISTICS

$T_j = 25\text{ }^\circ\text{C}$ unless otherwise specified

Collector cut-off current

$I_E = 0; V_{CB} = 20\text{ V}; T_j = 25\text{ }^\circ\text{C}$

$I_{CBO} < 100\text{ nA}$

$I_E = 0; V_{CB} = 20\text{ V}; T_j = 150\text{ }^\circ\text{C}$

$I_{CBO} < 5\text{ }\mu\text{A}$

Emitter cut-off current

$I_C = 0; V_{EB} = 5\text{ V}$

$I_{EBO} < 10\text{ }\mu\text{A}$

Base emitter voltage *

$I_C = 500\text{ mA}; V_{CE} = 1\text{ V}$

$V_{BE} < 1.2\text{ V}$

Saturation voltage

$I_C = 500\text{ mA}; I_B = 50\text{ mA}$

$V_{CEsat} < 700\text{ mV}$

D.C. current gain

$I_C = 500\text{ mA}; V_{CE} = 1\text{ V}$

$h_{FE} > 40$

$I_C = 100\text{ mA}; V_{CE} = 1\text{ V}; \text{BC817}; \text{BC818}$

$h_{FE} 100\text{ to }600$

BC817-16 }

BC818-16 }

$h_{FE} 100\text{ to }250$

BC817-25 }

BC818-25 }

$h_{FE} 160\text{ to }400$

BC817-40 }

BC818-40 }

$h_{FE} 250\text{ to }600$

Transition frequency at $f = 35\text{ MHz}$

$I_C = 10\text{ mA}; V_{CE} = 5\text{ V}$

f_T typ. 200 MHz

Collector capacitance at $f = 1\text{ MHz}$

$I_E = I_e = 0; V_{CB} = 10\text{ V}$

C_c typ. 5 pF

* V_{BE} decreases by about 2 mV/K with increasing temperature.

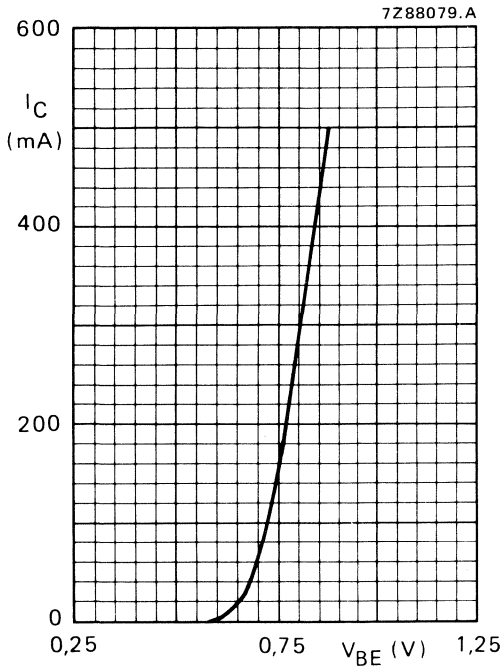

Fig. 2 $V_{CE} = 1 \text{ V}$; $T_j = 25 \text{ }^\circ\text{C}$. Typical values.

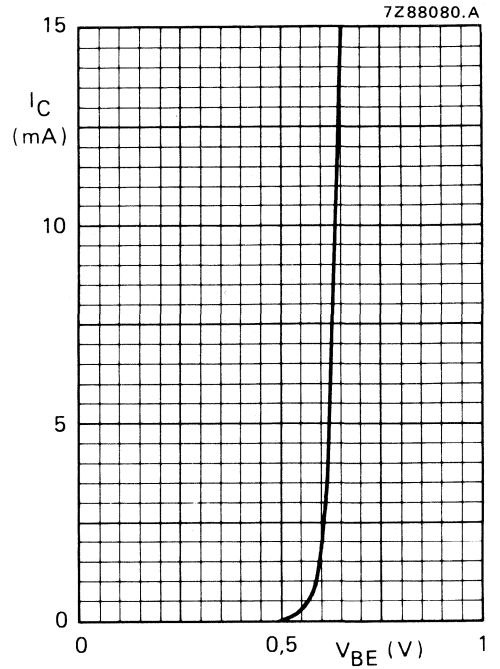

Fig. 3 $V_{CE} = 5 \text{ V}$; $T_j = 25 \text{ }^\circ\text{C}$. Typical values.

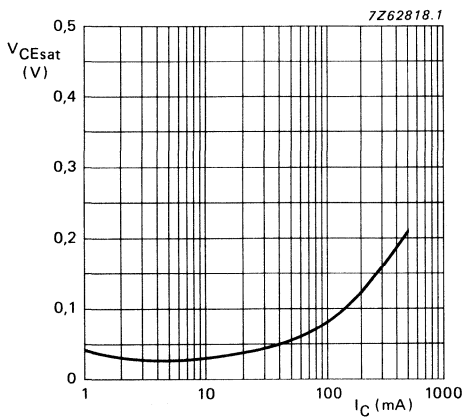

Fig. 4 $I_C/I_B = 10$; $T_j = 25 \text{ }^\circ\text{C}$.

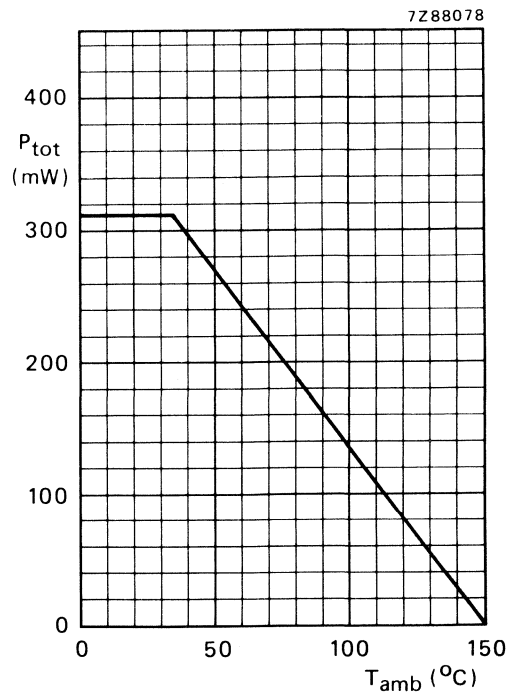

Fig. 5 Power derating curve.

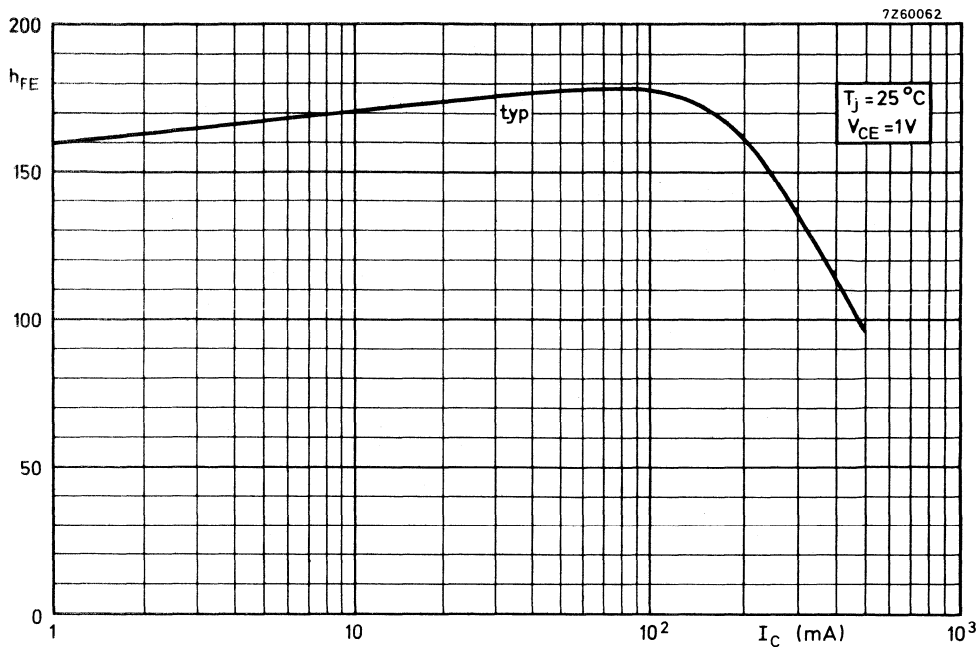

Fig. 6 D.C. current gain.

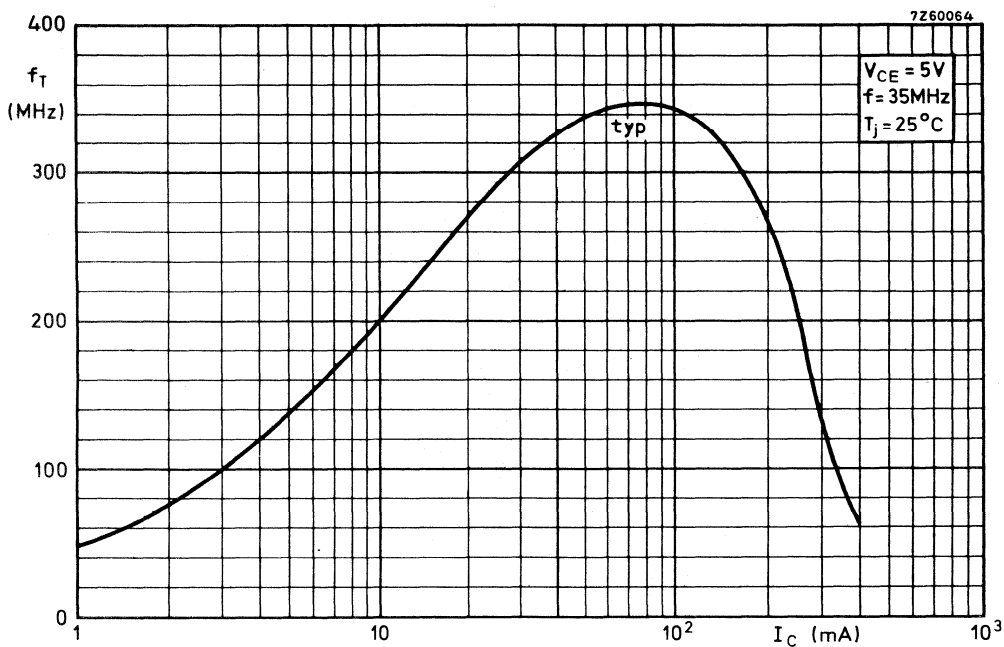

Fig. 7 Typical values transition frequency.

SILICON PLANAR EPITAXIAL TRANSISTORS

General purpose n-p-n transistors in a plastic SOT-23 variant, especially suitable for use in driver stages of audio amplifiers in thick and thin-film hybrid circuits.

QUICK REFERENCE DATA

		BC846	BC847	BC848	
Collector-emitter voltage ($V_{BE} = 0$)	V_{CES} max.	80	50	30	V
Collector-emitter voltage (open base)	V_{CEO} max.	65	45	30	V
Collector current (peak value)	I_{CM} max.	200	200	200	mA
Total power dissipation up to $T_{amb} = 60\text{ }^{\circ}\text{C}$	P_{tot} max.	200	200	200	mW
Junction temperature	T_j max.	150	150	150	$^{\circ}\text{C}$
Small-signal current gain $I_C = 2\text{ mA}; V_{CE} = 5\text{ V}; f = 1\text{ kHz}$	h_{fe} > <	125 500	125 900	125 900	
Transition frequency $I_C = 10\text{ mA}; V_{CE} = 5\text{ V}$	f_T typ.	300	300	300	MHz
Noise figure at $R_S = 2\text{ k}\Omega$ $I_C = 200\text{ }\mu\text{A}; V_{CE} = 5\text{ V}$ $f = 1\text{ kHz}; B = 200\text{ Hz}$	F typ.	2	2	2	dB

MECHANICAL DATA

Fig. 1 SOT-23.

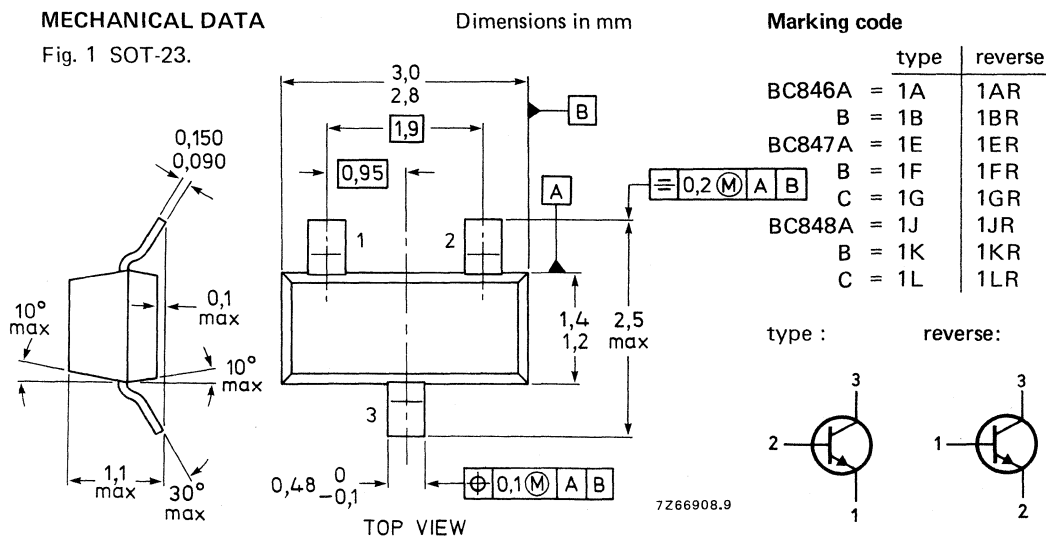

R-types are available on request

See also *Soldering recommendations*.

RATINGS

Limiting values in accordance with the Absolute Maximum System (IEC 134)

			BC846	BC847	BC848	
Collector-base voltage (open emitter)	V_{CBO}	max.	80	50	30	V
Collector-emitter voltage ($V_{BE} = 0$)	V_{CES}	max.	80	50	30	V
Collector-emitter voltage (open base)	V_{CEO}	max.	65	45	30	V
Emitter-base voltage (open collector)	V_{EBO}	max.	6	6	5	V
Collector current (d.c.)	I_C	max.		100		mA
Collector current (peak value)	I_{CM}	max.		200		mA
Emitter current (peak value)	$-I_{EM}$	max.		200		mA
Base current (peak value)	I_{BM}	max.		200		mA
Total power dissipation* up to $T_{amb} = 60\text{ }^{\circ}\text{C}$	P_{tot}	max.		200		mW
Storage temperature	T_{stg}		-65 to +150			$^{\circ}\text{C}$
Junction temperature	T_j	max.		150		$^{\circ}\text{C}$

THERMAL CHARACTERISTICS**

$$T_j = P (R_{th\ j-t} + R_{th\ t-s} + R_{th\ s-a}) + T_{amb}$$

Thermal resistance

From junction to tab	$R_{th\ j-t}$	=	60	K/W
From tab to soldering points	$R_{th\ t-s}$	=	280	K/W
From soldering points to ambient*	$R_{th\ s-a}$	=	90	K/W

* Mounted on a ceramic substrate of 8 mm x 10 mm x 0,7 mm.

** See *Thermal characteristics*.

CHARACTERISTICS

 $T_j = 25\text{ }^\circ\text{C}$ unless otherwise specified

Collector cut-off current

 $I_E = 0; V_{CB} = 30\text{ V}$ $I_E = 0; V_{CB} = 30\text{ V}; T_j = 150\text{ }^\circ\text{C}$

I_{CBO}	<	15 nA
I_{CBO}	<	5 μA

Base-emitter voltage*

 $I_C = 2\text{ mA}; V_{CE} = 5\text{ V}$

V_{BE}	typ.	660 mV
	580 to	700 mV

 $I_C = 10\text{ mA}; V_{CE} = 5\text{ V}$

V_{BE}	<	770 mV
----------	---	--------

Saturation voltage**

 $I_C = 10\text{ mA}; I_B = 0,5\text{ mA}$

V_{CEsat}	typ.	90 mV
	<	250 mV

V_{BEsat}	typ.	700 mV
-------------	------	--------

 $I_C = 100\text{ mA}; I_B = 5\text{ mA}$

V_{CEsat}	typ.	200 mV
	<	600 mV

V_{BEsat}	typ.	900 mV
-------------	------	--------

Collector capacitance at $f = 1\text{ MHz}$ $I_E = I_e = 0; V_{CB} = 10\text{ V}$

C_C	typ.	2,5 pF
-------	------	--------

Transition frequency at $f = 35\text{ MHz}$ $I_C = 10\text{ mA}; V_{CE} = 5\text{ V}$

f_T	typ.	300 MHz
-------	------	---------

* V_{BE} decreases by about 2 mV/K with increasing temperature.** V_{BEsat} decreases by about 1,7 mV/K with increasing temperature.

BC846
BC847
BC848

		BC846	BC847	BC848	
Small signal current gain at f = 1 kHz					
$I_C = 2 \text{ mA}; V_{CE} = 5 \text{ V}$					
h_{fe}	>	125	125	125	
	<	500	900	900	
Noise figure at $R_S = 2 \text{ k}\Omega$					
$i_C = 200 \text{ }\mu\text{A}; V_{CE} = 5 \text{ V};$					
$f = 1 \text{ kHz}; B = 200 \text{ Hz}$					
F	typ.	2	2	2	dB
	<	10	10	10	dB
		BC846A	BC846B		
		BC847A	BC847B	BC847C	
		BC848A	BC848B	BC848C	
D.C. current gain					
$I_C = 10 \text{ }\mu\text{A}; V_{CE} = 5 \text{ V}$					
h_{FE}	typ.	90	150	270	
	>	110	200	420	
$I_C = 2 \text{ mA}; V_{CE} = 5 \text{ V}$					
h_{FE}	typ.	180	290	520	
	<	220	450	800	

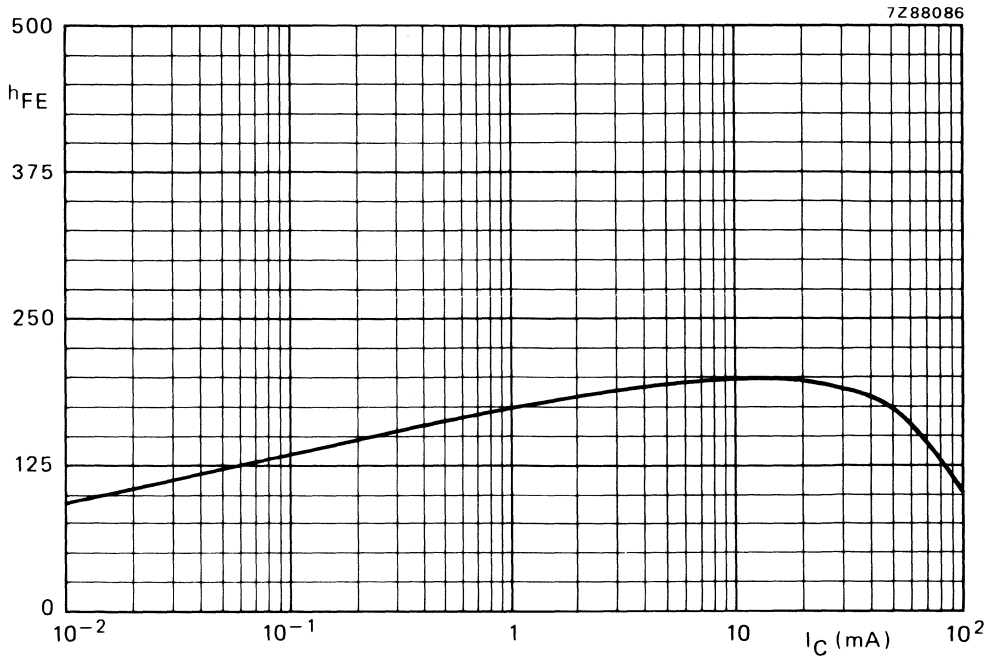

Fig. 3 Typical D.C. current gain for A-selections. $V_{CE} = 5\text{ V}$; $T_j = 25\text{ }^\circ\text{C}$.

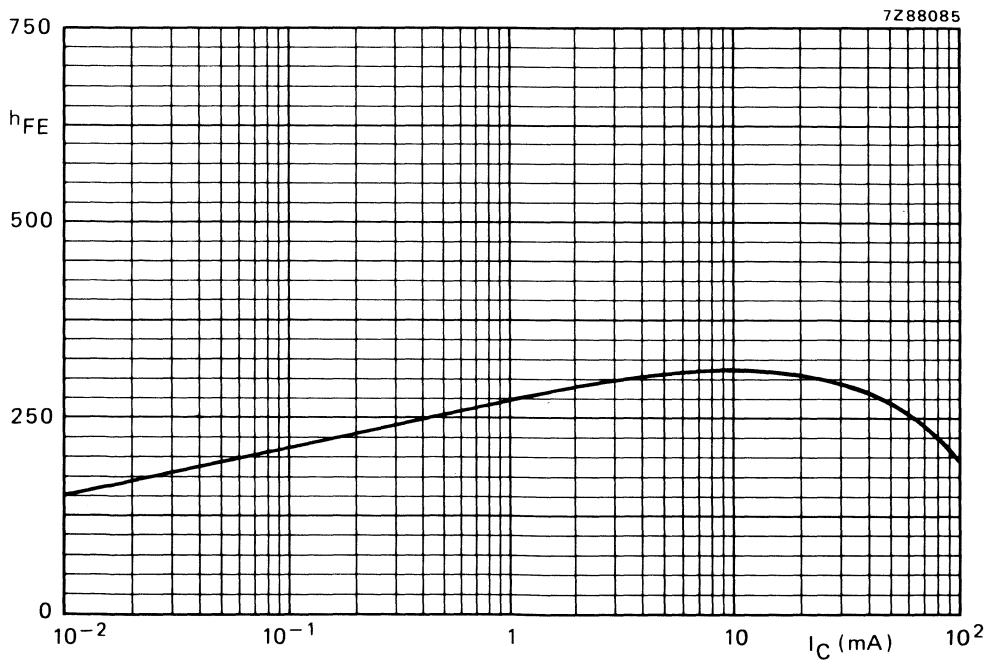

Fig. 4 Typical D.C. current gain for B-selections. $V_{CE} = 5\text{ V}$; $T_j = 25\text{ }^\circ\text{C}$.

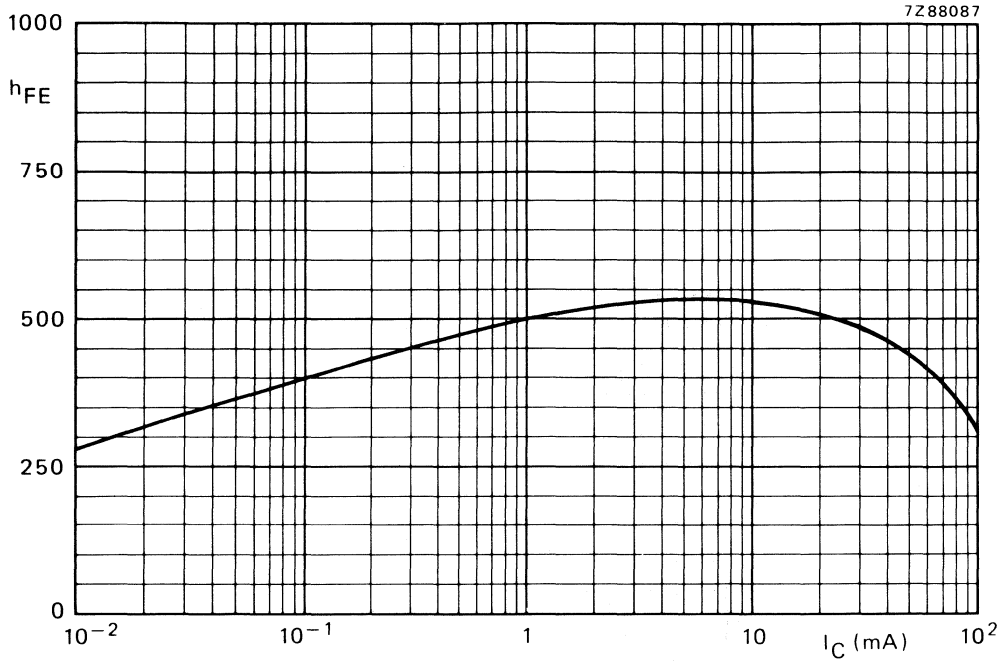

Fig. 5 Typical D.C. current gain for C-selections. $V_{CE} = 5\text{ V}$; $T_j = 25^\circ\text{C}$.

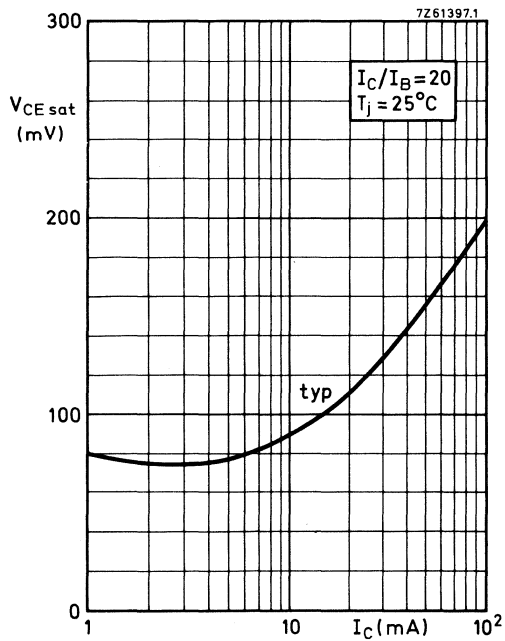

Fig. 6 Typical values.

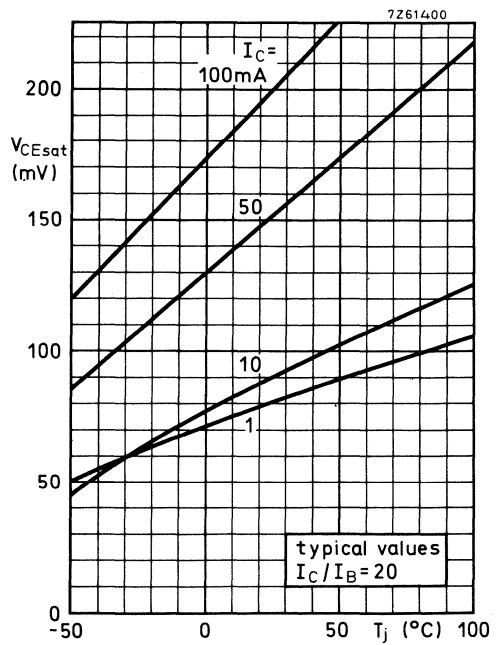

Fig. 7 Typical values.

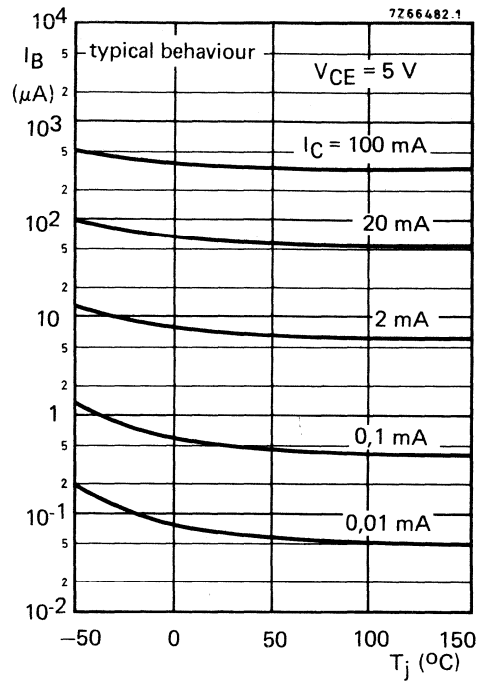

Fig. 8 Typical behaviour of base current versus junction temperature.

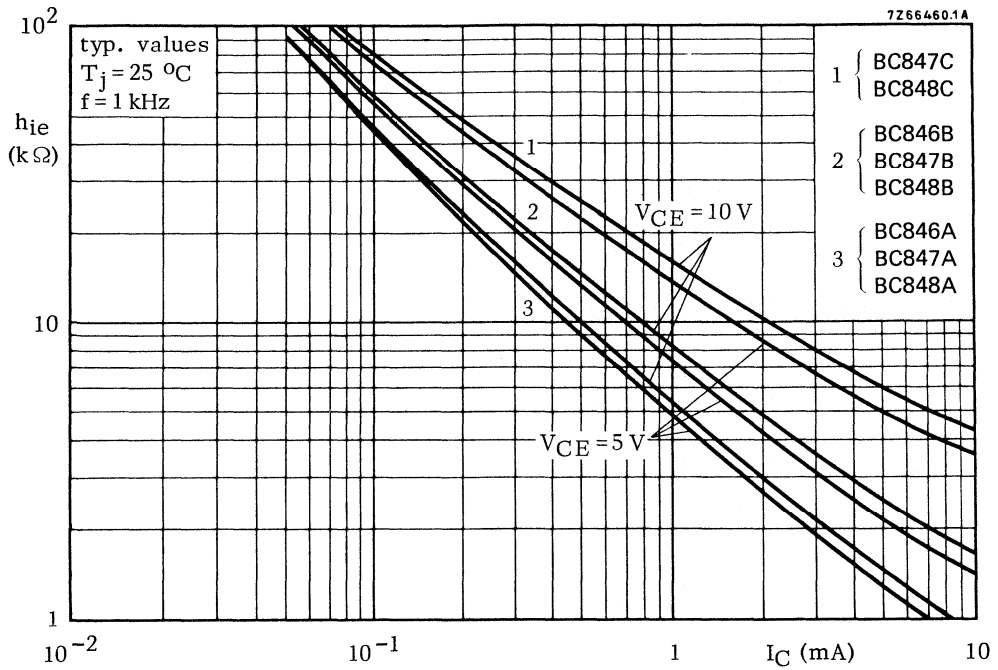

Fig. 9 Input impedance. 1 = C selections; 2 = B selections; 3 = A selections.

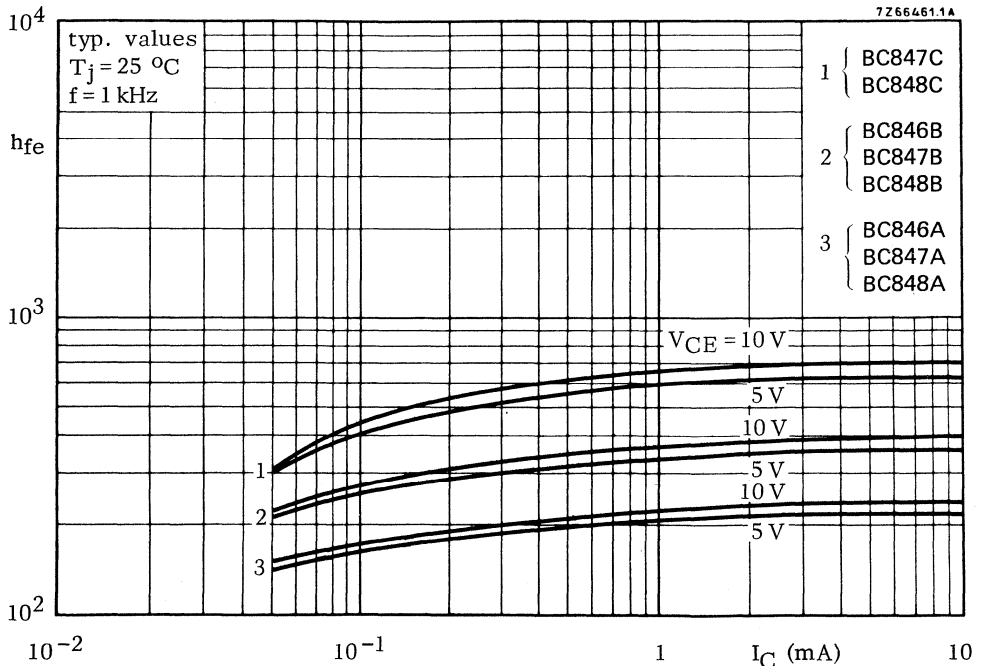

Fig. 10 Small signal current gain. 1 = C-; 2 = B- and 3 = A- selections.

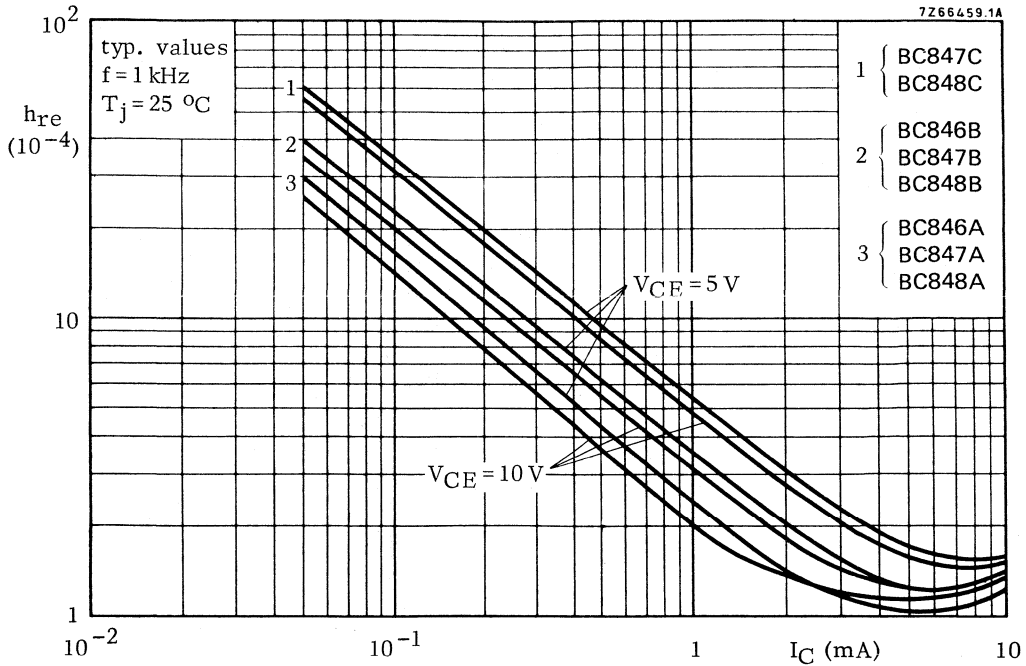

Fig. 11 Reverse voltage transfer ratio. 1 = C-; 2 = B- and 3 = A-selections.

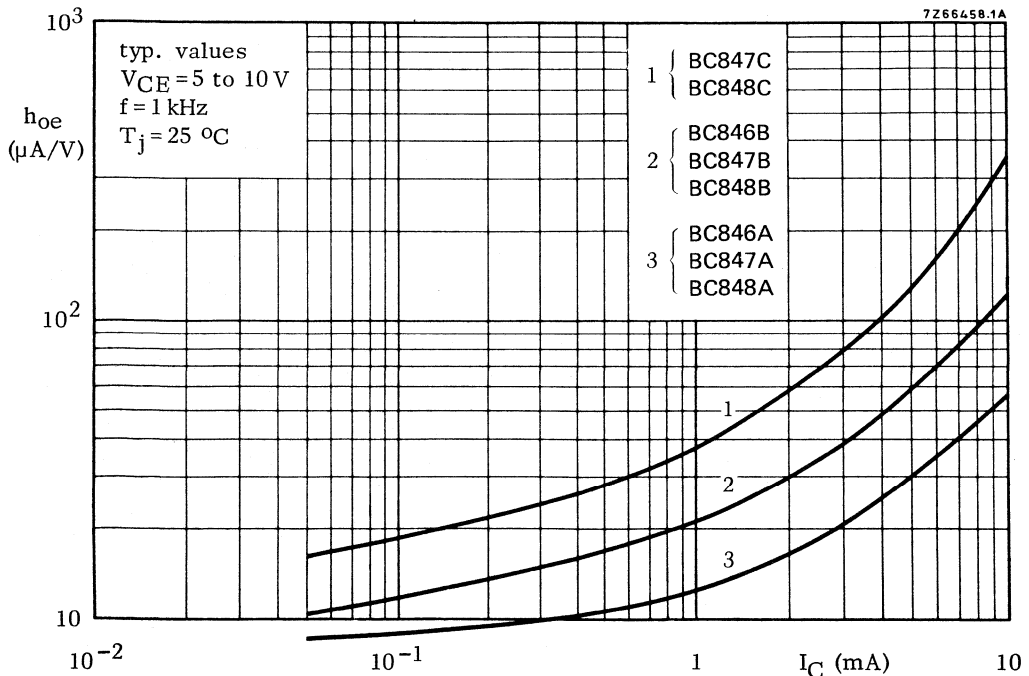

Fig. 12 Output admittance. 1 = C-; 2 = B- and 3 = A-selections.

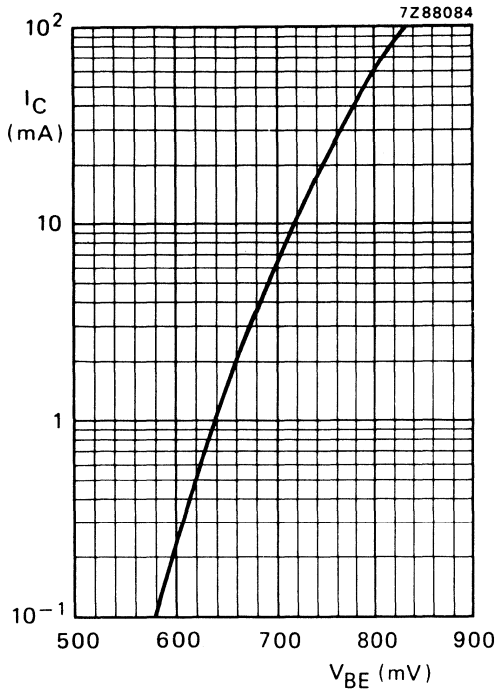

Fig. 13 Typical values at $V_{CE} = 5\text{ V}$; $T_j = 25\text{ }^\circ\text{C}$.

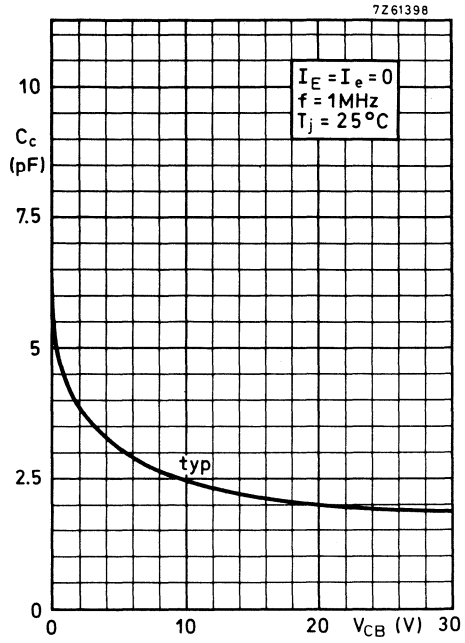

Fig. 14 Typical values.

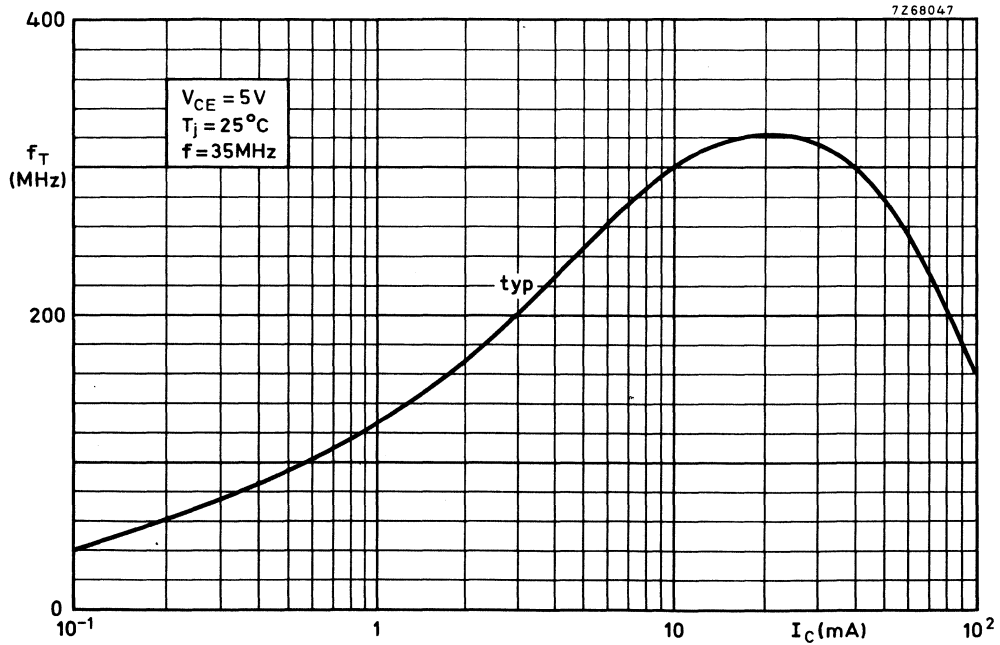

Fig. 15 Typical values transition frequency.

SILICON PLANAR EPITAXIAL TRANSISTORS

N-P-N transistors in a plastic SOT-23 envelope, primarily intended for low-noise input stages in tape recorders, hi-fi amplifiers and other audio-frequency equipment in thick and thin-film hybrid circuits.

QUICK REFERENCE DATA

			BC849	BC850	
Collector-emitter voltage ($V_{BE} = 0$)	V_{CES}	max.	30	50	V
Collector-emitter voltage (open base)	V_{CEO}	max.	30	45	V
Collector current (peak value)	I_{CM}	max.	200	200	mA
Total power dissipation up to $T_{amb} = 60\text{ }^{\circ}\text{C}$	P_{tot}	max.	200	200	mW
Junction temperature	T_j	max.	150	150	$^{\circ}\text{C}$
Small-signal current gain $I_C = 2\text{ mA}; V_{CE} = 5\text{ V}; f = 1\text{ kHz}$	h_{fe}	>	240	240	
		<	900	900	
Transition frequency $I_C = 10\text{ mA}; V_{CE} = 5\text{ V}$	f_T	typ.	300	300	MHz
Noise figure at $R_S = 2\text{ k}\Omega$ $I_C = 200\text{ }\mu\text{A}; V_{CE} = 5\text{ V}$ $f = 30\text{ Hz to }15\text{ kHz}$	F	typ.	1,4	1,4	dB
		<	4	3	dB
$f = 1\text{ kHz}; B = 200\text{ Hz}$	F	typ.	1,2	1	dB
$f = 10\text{ Hz to }50\text{ Hz}$ (equivalent noise voltage)	V_n	<	—	0,135	μV

MECHANICAL DATA

Fig. 1 SOT-23.

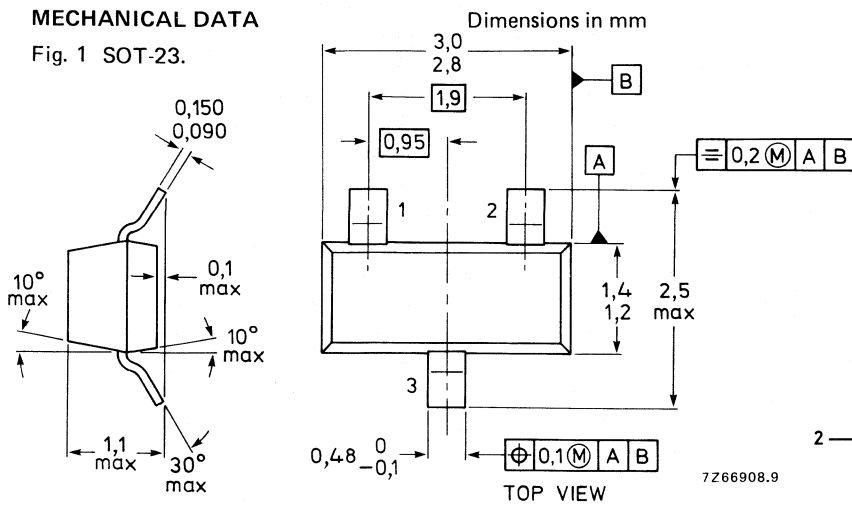

Marking code

BC849B = 2B
BC849C = 2C
BC850B = 2F
BC850C = 2G

BC849BR = 2BR
BC849CR = 2CR
BC850BR = 2FR
BC850CR = 2GR

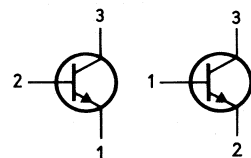

R-types are available on request

RATINGS

Limiting values in accordance with the Absolute Maximum System (IEC 134)

			BC849	BC850	
Collector-base voltage (open emitter)	V_{CBO}	max.	30	50	V
Collector-emitter voltage ($V_{BE} = 0$)	V_{CES}	max.	30	50	V
Collector-emitter voltage (open base)	V_{CEO}	max.	30	45	V
Emitter-base voltage (open collector)	V_{EBO}	max.	5	5	V
Collector current (d.c.)	I_C	max.	100		mA
Collector current (peak value)	I_{CM}	max.	200		mA
Emitter current (peak value)	$-I_{EM}$	max.	200		mA
Base current (peak value)	I_{BM}	max.	200		mA
Total power dissipation up to $T_{amb} = 60\text{ }^\circ\text{C}^{**}$	P_{tot}	max.	200		mW
Storage temperature	T_{stg}		-65 to +150		$^\circ\text{C}$
Junction temperature	T_j	max.	150		$^\circ\text{C}$

THERMAL CHARACTERISTICS*

$$T_j = P \times (R_{th\ j-t} + R_{th\ t-s} + R_{th\ s-a}) + T_{amb}$$

Thermal resistance

From junction to tab	$R_{th\ j-t}$	=	60	K/W
From tab to soldering points	$R_{th\ t-s}$	=	280	K/W
From soldering points to ambient**	$R_{th\ s-a}$	=	90	K/W

* See *Thermal characteristics*.

** Mounted on a ceramic substrate of 8 mm x 10 mm x 0,7 mm.

CHARACTERISTICS

$T_j = 25\text{ }^\circ\text{C}$ unless otherwise specified

Collector cut-off current

$$I_E = 0; V_{CB} = 30\text{ V}$$

$$I_{CBO} < 15\text{ nA}$$

$$I_E = 0; V_{CB} = 30\text{ V}; T_j = 150\text{ }^\circ\text{C}$$

$$I_{CBO} < 5\text{ }\mu\text{A}$$

Base emitter voltage*

$$I_C = 2\text{ mA}; V_{CE} = 5\text{ V}$$

$$V_{BE} \text{ typ. } 660\text{ mV}$$

$$580\text{ to } 700\text{ mV}$$

$$I_C = 10\text{ mA}; V_{CE} = 5\text{ V}$$

$$V_{BE} < 770\text{ mV}$$

Saturation voltages**

$$I_C = 10\text{ mA}; I_B = 0,5\text{ mA}$$

$$V_{CEsat} \text{ typ. } 90\text{ mV}$$

$$< 250\text{ mV}$$

$$V_{BEsat} \text{ typ. } 700\text{ mV}$$

$$I_C = 100\text{ mA}; I_B = 5\text{ mA}$$

$$V_{CEsat} \text{ typ. } 200\text{ mV}$$

$$< 600\text{ mV}$$

$$V_{BEsat} \text{ typ. } 900\text{ mV}$$

Collector capacitance at $f = 1\text{ MHz}$

$$I_E = I_e = 0; V_{CB} = 10\text{ V}$$

$$C_c \text{ typ. } 2,5\text{ pF}$$

Transition frequency at $f = 35\text{ MHz}$

$$I_C = 10\text{ mA}; V_{CE} = 5\text{ V}$$

$$f_T \text{ typ. } 300\text{ MHz}$$

* V_{BE} decreases by about 2 mV/K with increasing temperature.

** V_{BEsat} decreases by about $1,7\text{ mV/K}$ with increasing temperature.

BC849
BC850

		BC849	BC850		
Small signal current gain at $f = 1 \text{ kHz}$					
$I_C = 2 \text{ mA}; V_{CE} = 5 \text{ V}$					
h_{fe}	$>$	240	240		
	$<$	900	900		
Noise figure at $R_S = 2 \text{ k}\Omega$					
$I_C = 200 \text{ }\mu\text{A}; V_{CE} = 5 \text{ V}$					
$f = 30 \text{ Hz to } 15 \text{ kHz}$					
F	typ.	1,4	1,4		dB
	$<$	4	3		dB
F	typ.	1,2	1		dB
	$<$	4	4		dB
Equivalent noise voltage at $R_S = 2 \text{ k}\Omega$					
$I_C = 200 \text{ }\mu\text{A}; V_{CE} = 5 \text{ V}$					
$f = 10 \text{ Hz to } 50 \text{ Hz}; T_{amb} = 25 \text{ }^\circ\text{C}$					
V_n	max.	—	0,135		μV
		B-selections	C-selections		
D.C. current gain					
$I_C = 10 \text{ }\mu\text{A}; V_{CE} = 5 \text{ V}$					
h_{FE}	typ.	150	270		
	$>$	200	420		
$I_C = 2 \text{ mA}; V_{CE} = 5 \text{ V}$					
h_{FE}	typ.	290	520		
	$<$	450	800		

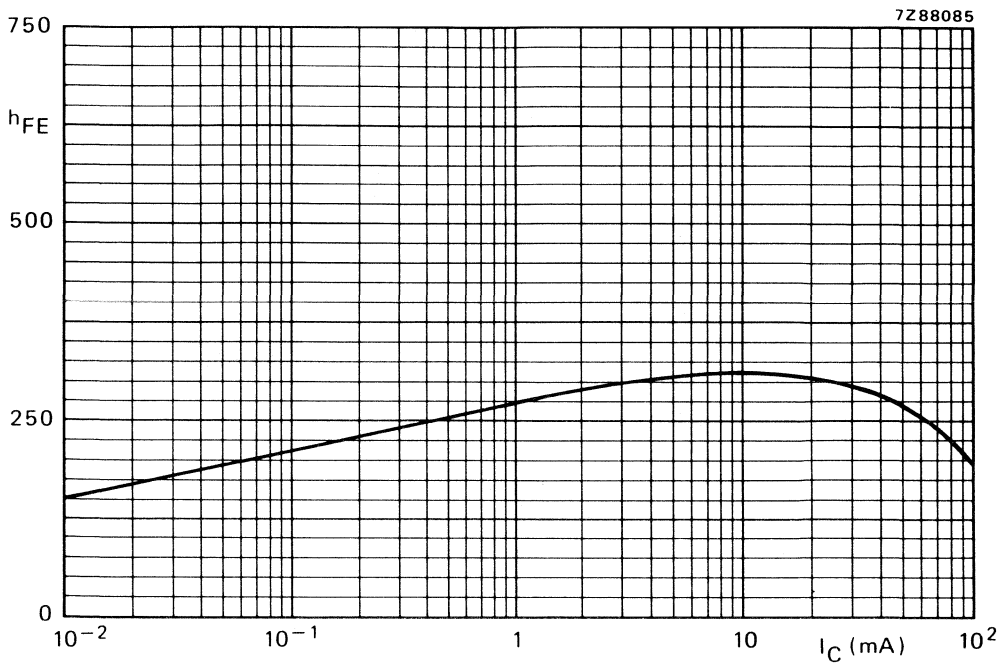

Fig. 3 Typical D.C. current gain B selections. $V_{CE} = 5\text{ V}$; $T_j = 25\text{ }^\circ\text{C}$.

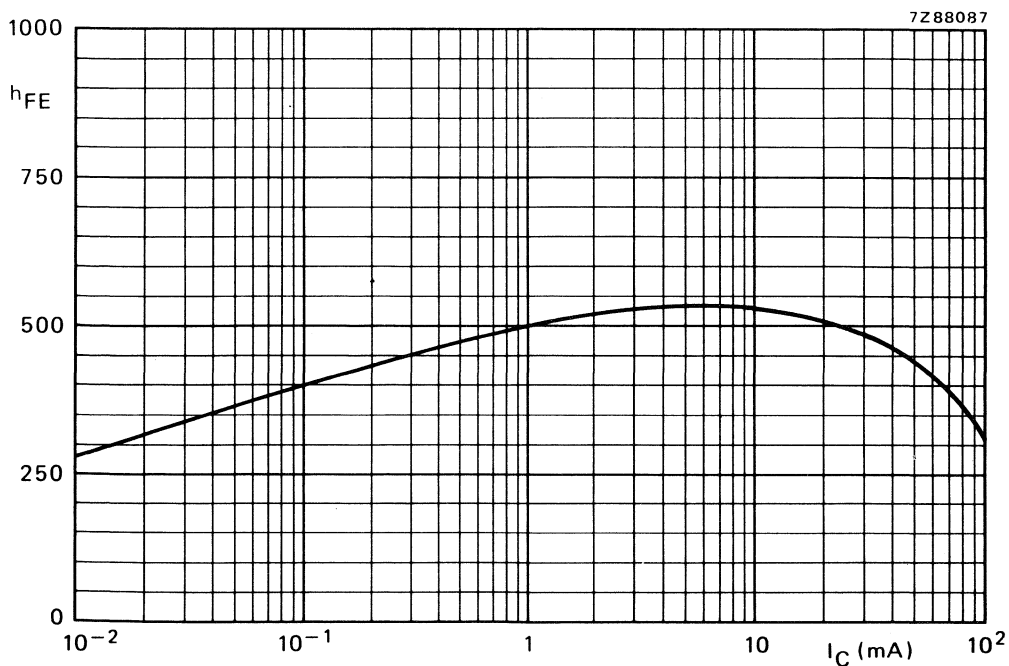

Fig. 4 Typical D.C. current gain C selections. $V_{CE} = 5\text{ V}$; $T_j = 25\text{ }^\circ\text{C}$.

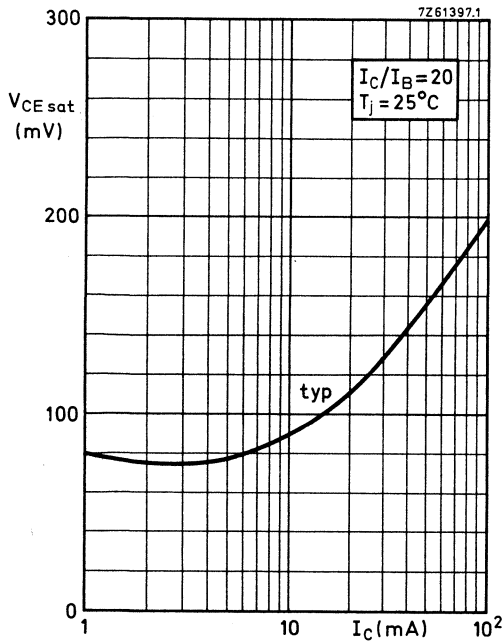

Fig. 5 Typical values.

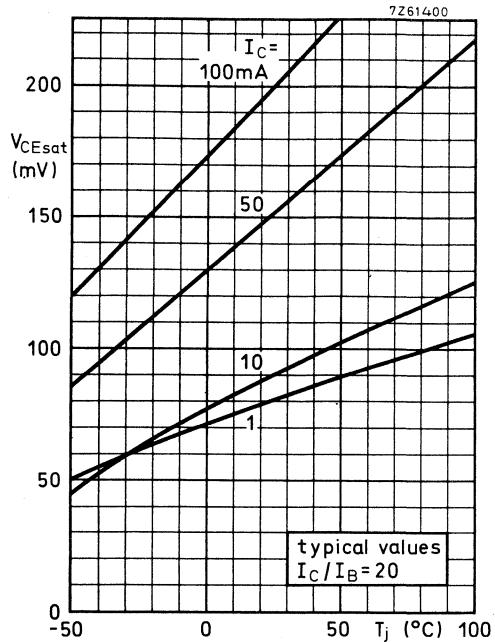

Fig. 6 Typical values; $I_C/I_B = 20$.

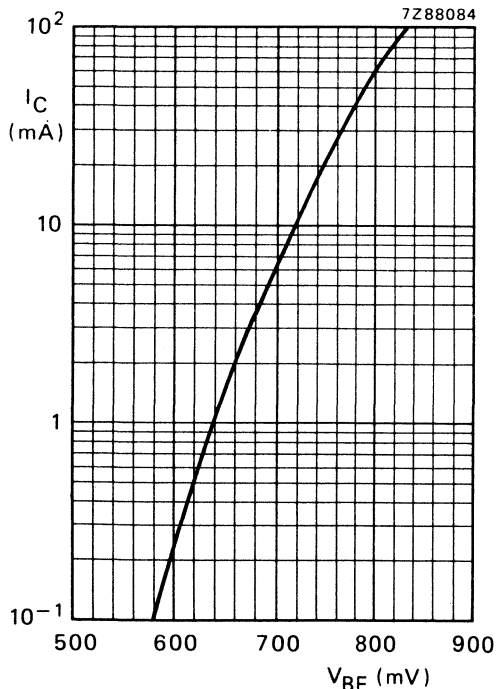

Fig. 7 Typical values $V_{CE} = 5\text{ V}$; $T_j = 25^\circ\text{C}$.

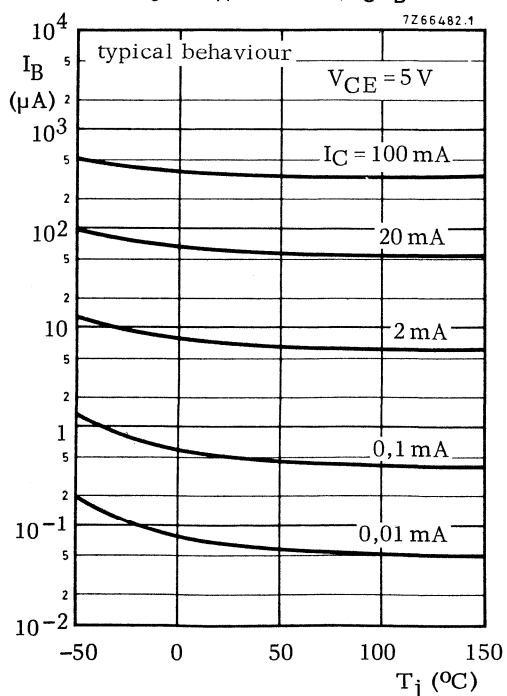

Fig. 8 Typical values.

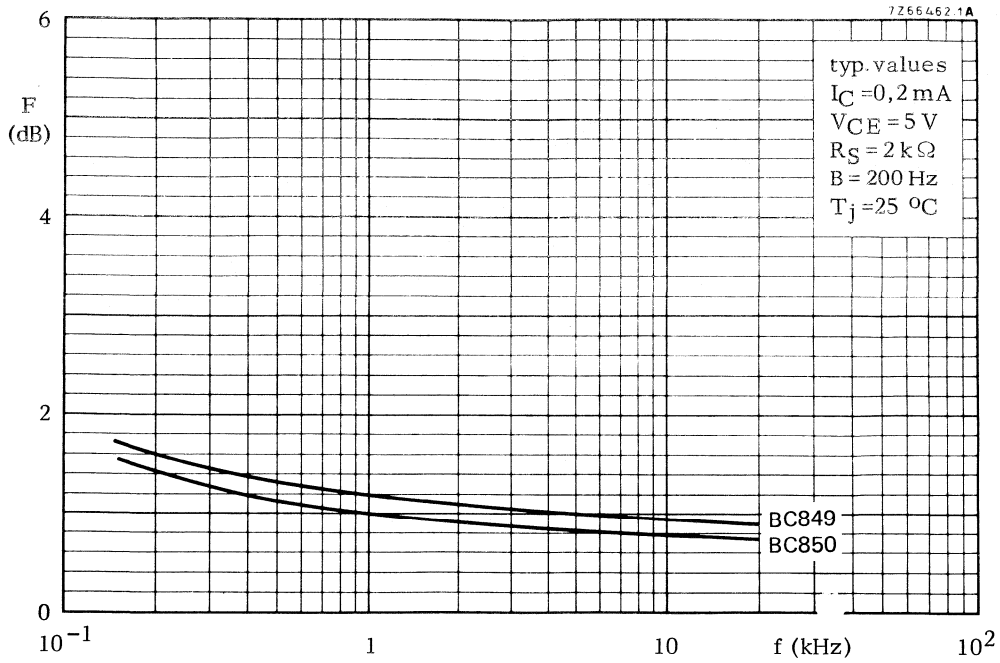

Fig. 9.

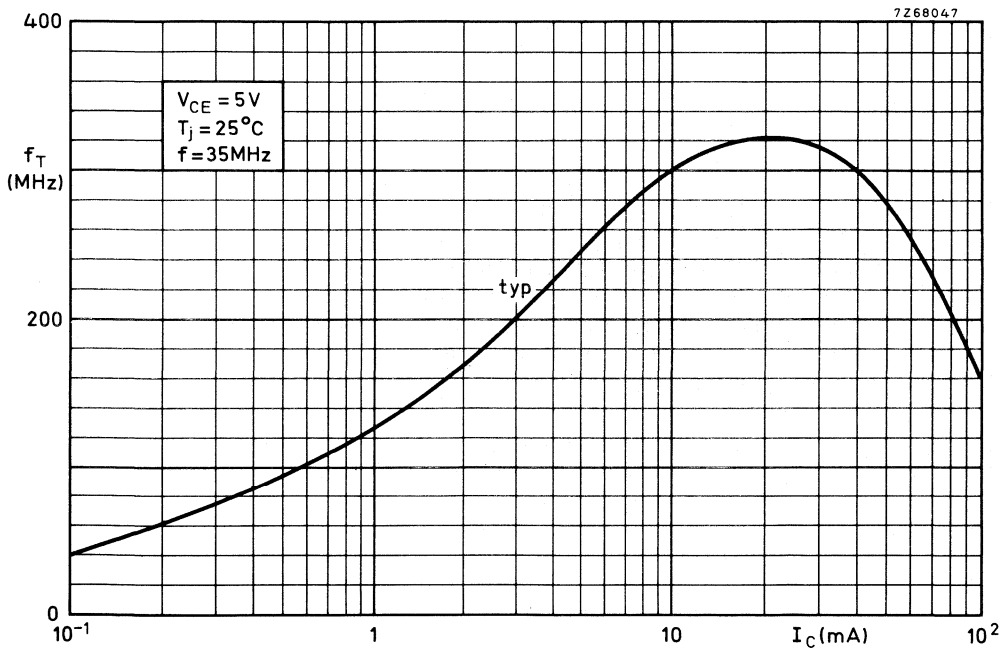

Fig. 10.

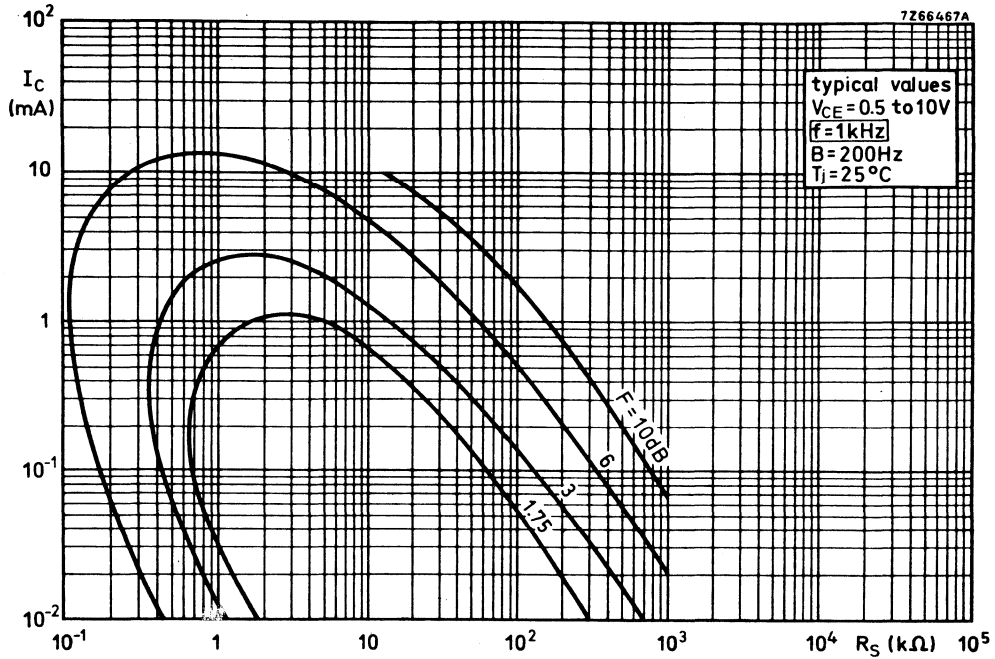

Fig. 11 Curves of constant noise figure for BC849.

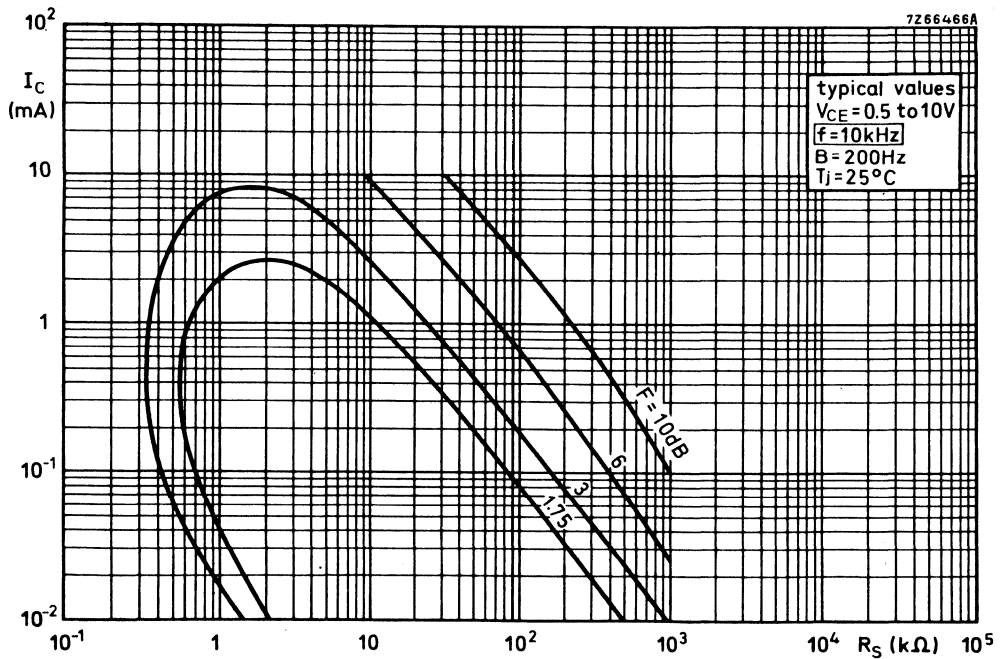

Fig. 12 Curves of constant noise figure for BC849.

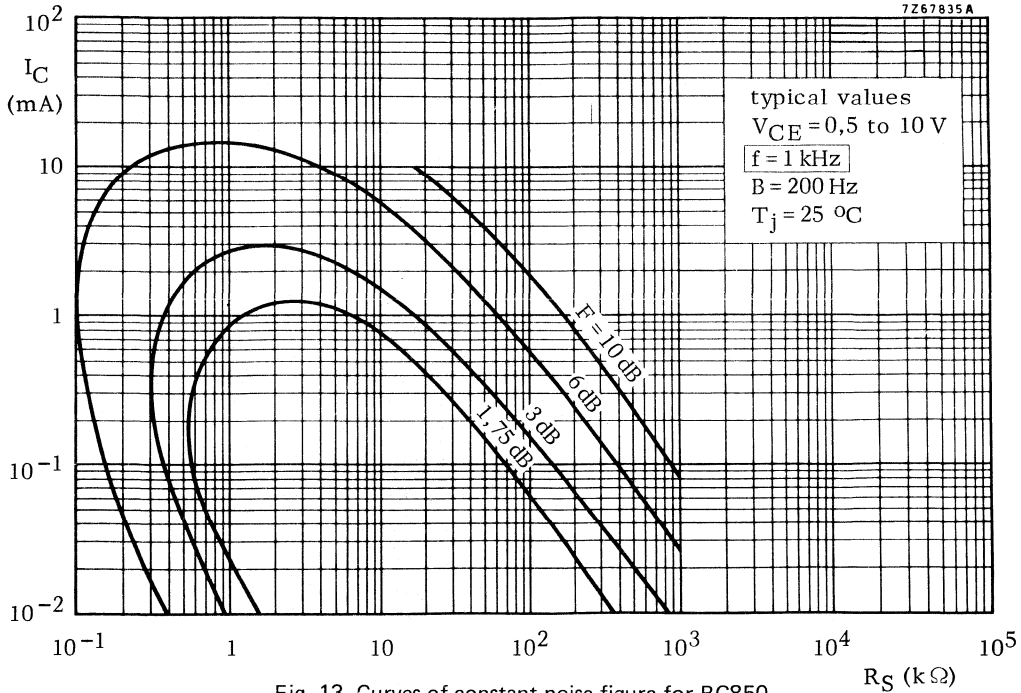

Fig. 13 Curves of constant noise figure for BC850.

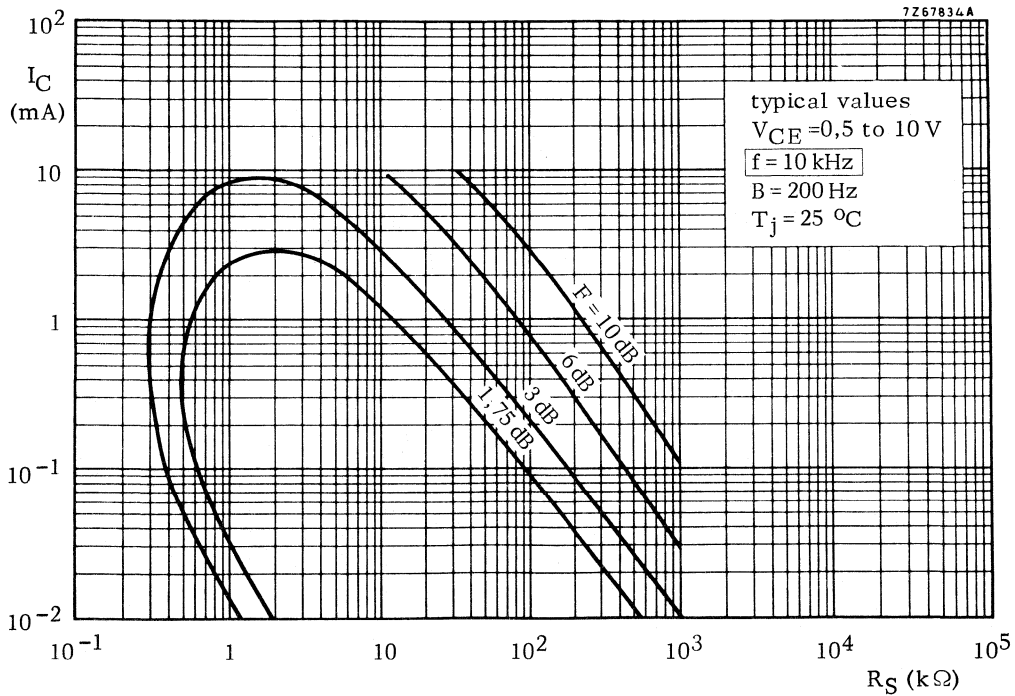

Fig. 14 Curves of constant noise figure for BC850.

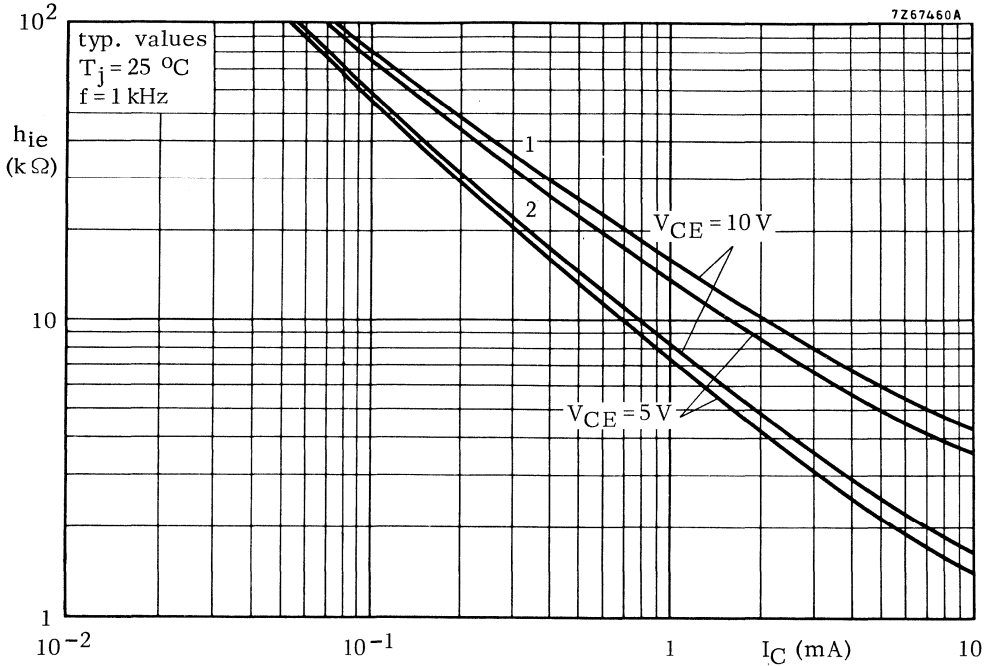

Fig. 15 Typical values. 1 = C selections; 2 = B selections.

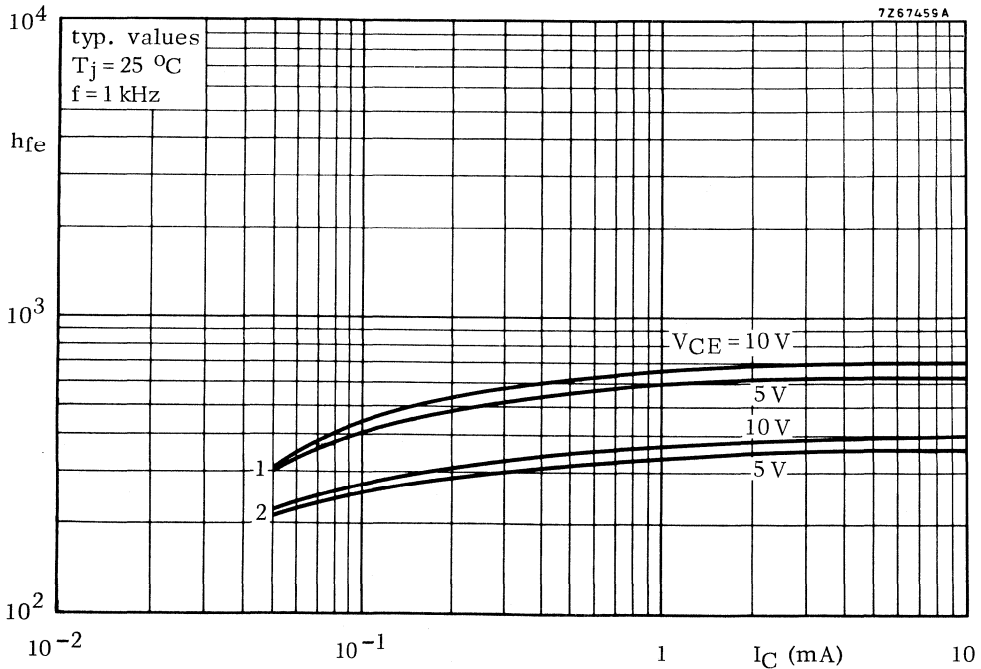

Fig. 16 Typical values. 1 = C selections; 2 = B selections.

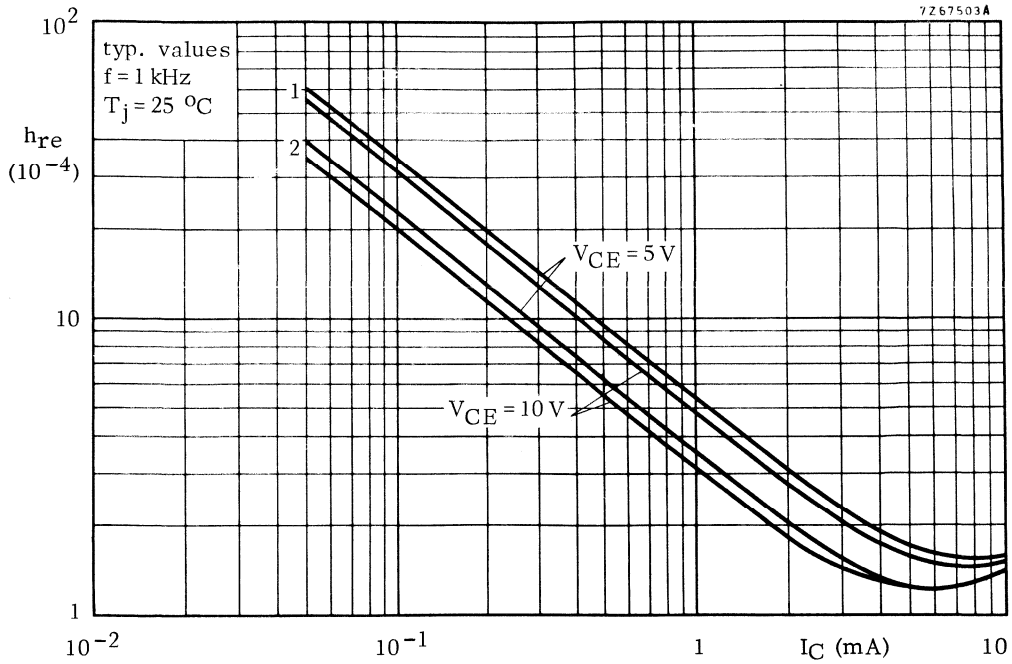

Fig. 17 Typical values. 1 = C selections; 2 = B selections.

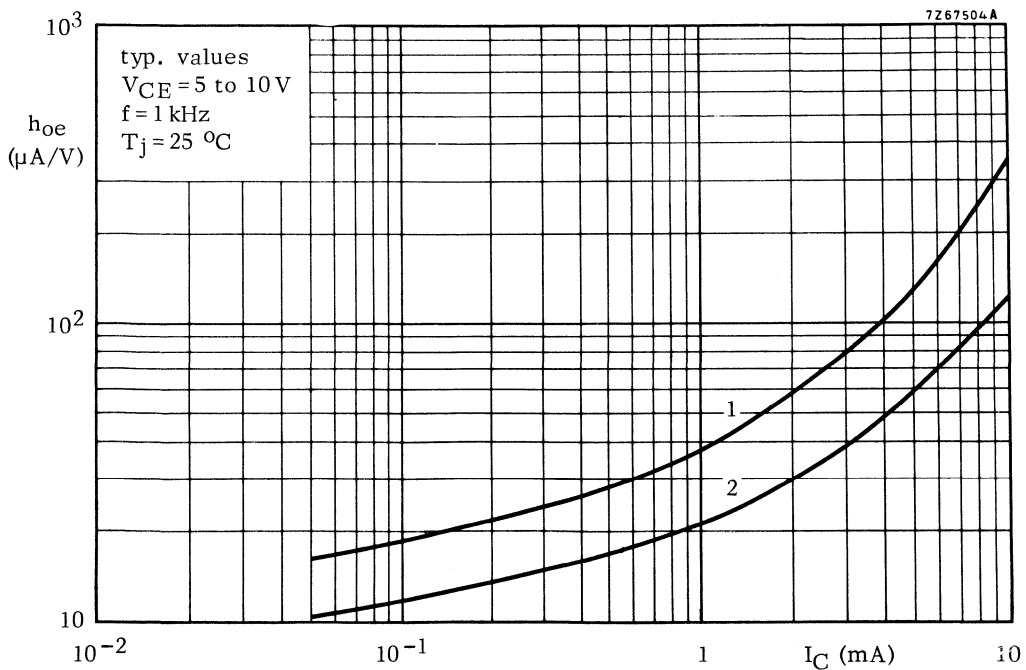

Fig. 18 Typical values. 1 = C selections; 2 = B selections.

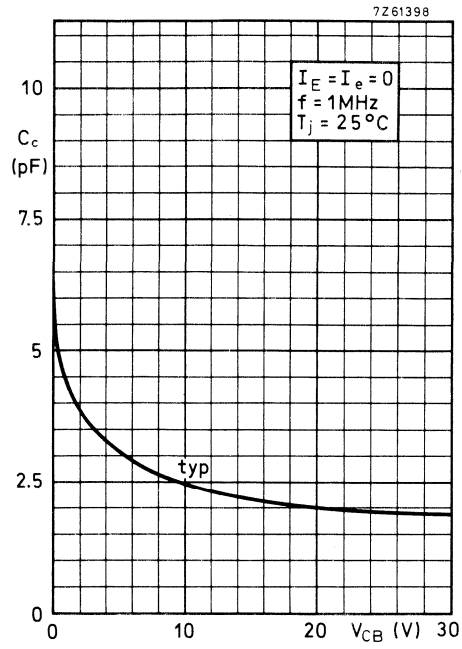

Fig. 19 Typical values.

SILICON PLANAR EPITAXIAL TRANSISTORS

P-N-P transistors, in a SOT-23 plastic envelope for use in driver and output stages of audio amplifiers in thick and thin-film circuits.

QUICK REFERENCE DATA

		BC856	BC857	BC858
Collector-emitter voltage (+ $V_{BE} = 1\text{ V}$)	$-V_{CEX}$	max. 80	50	30 V
Collector-emitter voltage (open base)	$-V_{CEO}$	max. 65	45	30 V
Collector current (peak value)	$-I_{CM}$	max.	200	mA
Total power dissipation up to $T_{amb} = 60\text{ }^{\circ}\text{C}$	P_{tot}	max.	200	mW
Junction temperature	T_j	max.	150	$^{\circ}\text{C}$
Small-signal current gain $-I_C = 2\text{ mA}; -V_{CE} = 5\text{ V}; f = 1\text{ kHz}$	h_{fe}		75 to 900	
Transition frequency at $f = 35\text{ MHz}$ $-I_C = 10\text{ mA}; -V_{CE} = 5\text{ V}$	f_T	typ.	150	MHz
Noise figure at $R_S = 2\text{ k}\Omega$ $-I_C = 200\text{ }\mu\text{A}; -V_{CE} = 5\text{ V}$ $f = 1\text{ kHz}; B = 200\text{ Hz}$	F	<	10	dB

MECHANICAL DATA

Fig. 1 SOT-23.

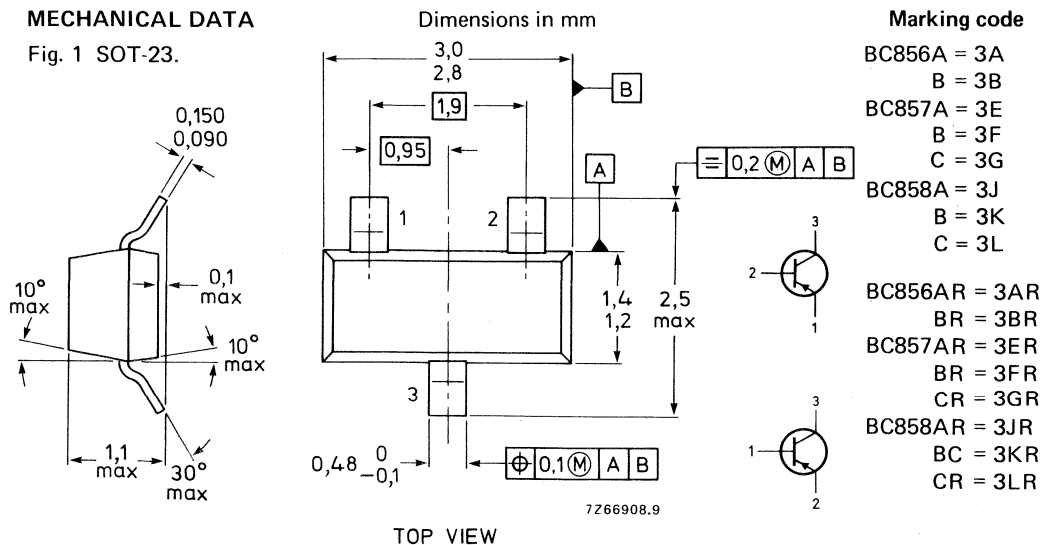

R-types are available on request

See also *Soldering recommendations*.

RATINGS

Limiting values in accordance with the Absolute Maximum System (IEC 134)

		BC856	BC857	BC858
Collector-base voltage (open emitter)	$-V_{CBO}$	max. 80	50	30 V
Collector-emitter voltage (+ $V_{BE} = 1$ V)	$-V_{CEX}$	max. 80	50	30 V
Collector-emitter voltage (open base)	$-V_{CEO}$	max. 65	45	30 V
Emitter-base voltage (open collector)	$-V_{EBO}$	max. 5	5	5 V
Collector current (d.c.)	$-I_C$	max.	100	mA
Collector current (peak value)	$-I_{CM}$	max.	200	mA
Emitter current (peak value)	I_{EM}	max.	200	mA
Base current (peak value)	$-I_{BM}$	max.	200	mA
Total power dissipation ** up to $T_{amb} = 60$ °C	P_{tot}	max.	200	mW
Storage temperature	T_{stg}		-65 to +150	°C
Junction temperature	T_j	max.	150	°C

THERMAL CHARACTERISTICS*

$$T_j = P_x (R_{th j-t} + R_{th t-s} + R_{th s-a}) + T_{amb}$$

Thermal resistance

From junction to tab	$R_{th j-t}$	=	60	K/W
From tab to soldering points	$R_{th t-s}$	=	280	K/W
From soldering points to ambient **	$R_{th s-a}$	=	90	K/W

CHARACTERISTICS

$T_j = 25$ °C unless otherwise specified

Collector cut-off current

$I_E = 0; -V_{CB} = 30$ V; $T_j = 25$ °C	$-I_{CBO}$	typ.	1	nA
		<	15	nA
$T_j = 150$ °C	$-I_{CBO}$	<	4	µA

Base-emitter voltage [▲]

$-I_C = 2$ mA; $-V_{CE} = 5$ V	$-V_{BE}$	typ.	650	mV
		<	600 to 750	mV
$-I_C = 10$ mA; $-V_{CE} = 5$ V	$-V_{BE}$	<	820	mV

[▲] $-V_{BE}$ decreases by about 2 mV/K with increasing temperature.

* See *Thermal characteristics*.

** Mounted on a ceramic substrate of 8 mm x 10 mm x 0,7 mm.

Saturation voltages *

$-I_C = 10 \text{ mA}; -I_B = 0,5 \text{ mA}$	$-V_{CEsat}$	typ.	75 mV
		<	300 mV
$-I_C = 100 \text{ mA}; -I_B = 5 \text{ mA}$	$-V_{BEsat}$	typ.	700 mV
	$-V_{CEsat}$	typ.	250 mV
		<	650 mV
	$-V_{BEsat}$	typ.	850 mV

Knee voltage

$-I_C = 10 \text{ mA}; -I_B = \text{value for which}$	$-V_{CEK}$	typ.	250 mV
$-I_C = 11 \text{ mA at } -V_{CE} = 1 \text{ V}$			

Collector capacitance at $f = 1 \text{ MHz}$

$I_E = I_e = 0; -V_{CB} = 10 \text{ V}$	C_c	typ.	4,5 pF
---	-------	------	--------

Transition frequency at $f = 35 \text{ MHz}$

$-I_C = 10 \text{ mA}; -V_{CE} = 5 \text{ V}$	f_T	typ.	150 MHz
---	-------	------	---------

Small-signal current gain at $f = 1 \text{ kHz}$

$-I_C = 2 \text{ mA}; -V_{CE} = 5 \text{ V}$	h_{fe}	75 to 900	
--	----------	-----------	--

Noise figure at $R_S = 2 \text{ k}\Omega$

$-I_C = 200 \mu\text{A}; -V_{CE} = 5 \text{ V}$	F	typ.	2 dB
$f = 1 \text{ kHz}; B = 200 \text{ Hz}$			

D.C. current gain

$-I_C = 2 \text{ mA}; -V_{CE} = 5 \text{ V}$	BC856/857	h_{FE}	75 to 475
	BC858	h_{FE}	75 to 800
	BC856A/857A/858A	h_{FE}	125 to 250
	BC856B/857B/858B	h_{FE}	220 to 475
	BC857C/858C	h_{FE}	420 to 800

* $-V_{BEsat}$ decreases by about 1,7 mV/K with increasing temperature.

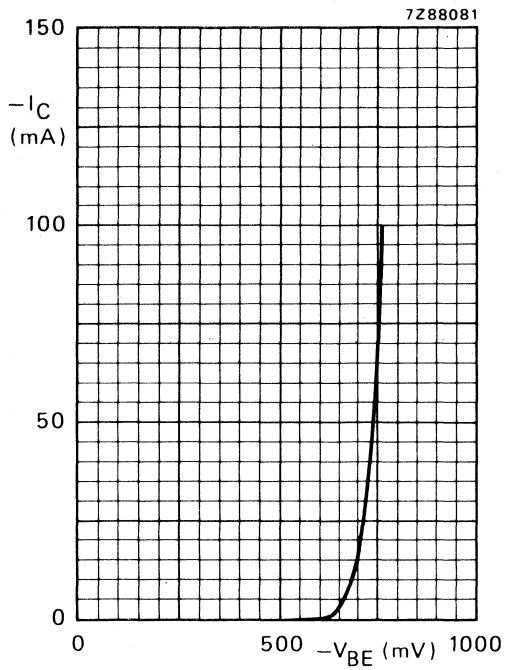

Fig. 3 Typical values. $-V_{CE} = 5\text{ V}$; $T_j = 25\text{ }^\circ\text{C}$.

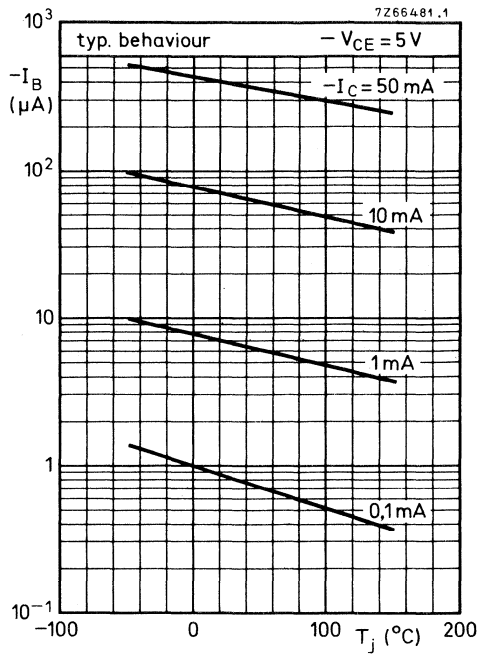

Fig. 4 Typical values.

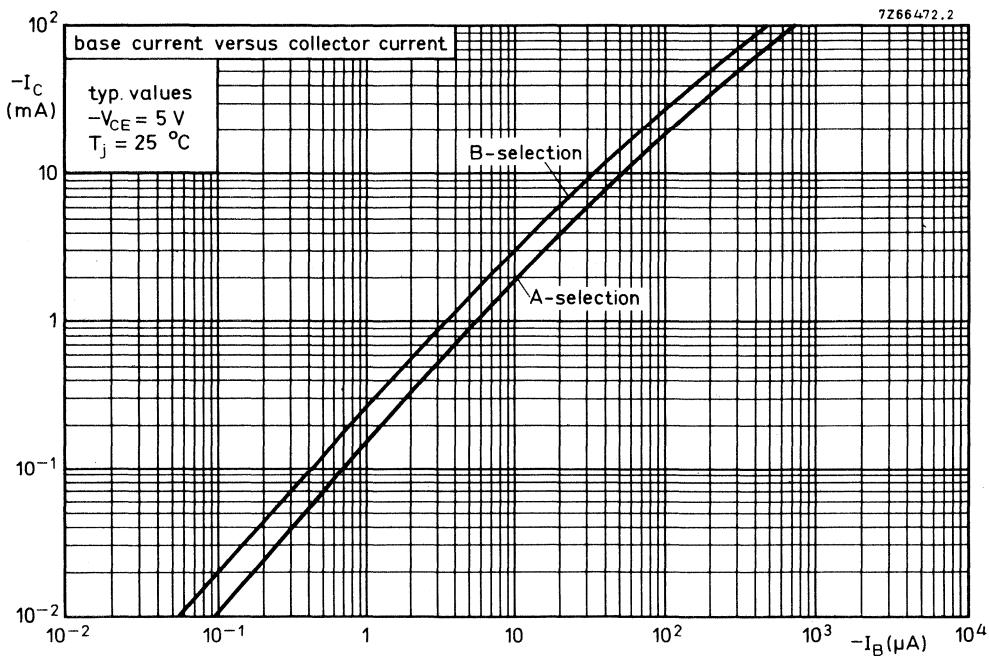

Fig. 5.

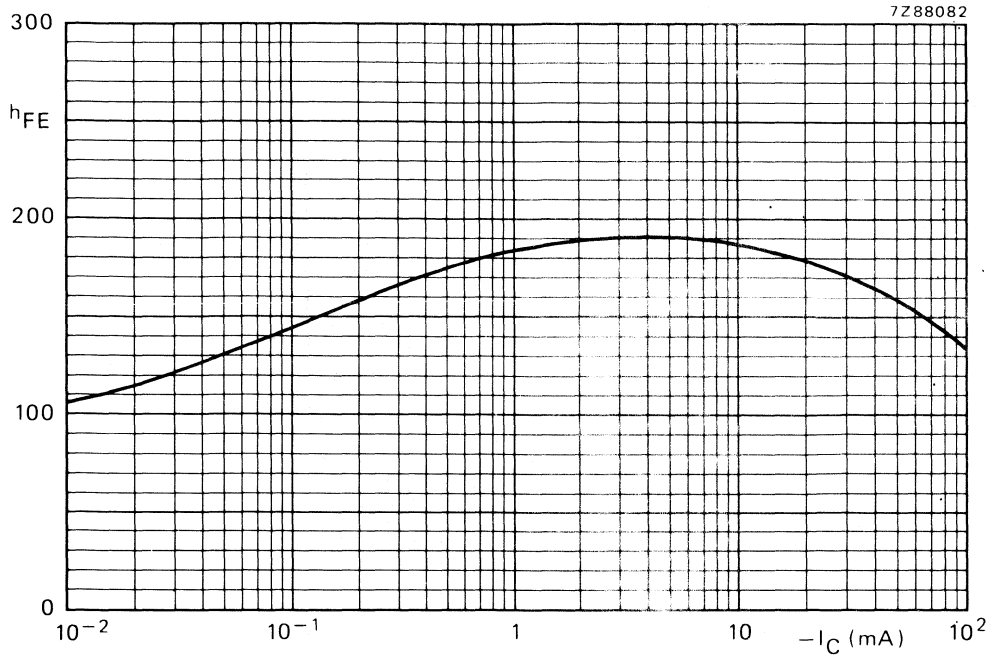

Fig. 6 Typical values D.C. current gain A-selections. $-V_{CE} = 5$ V; $T_j = 25$ °C.

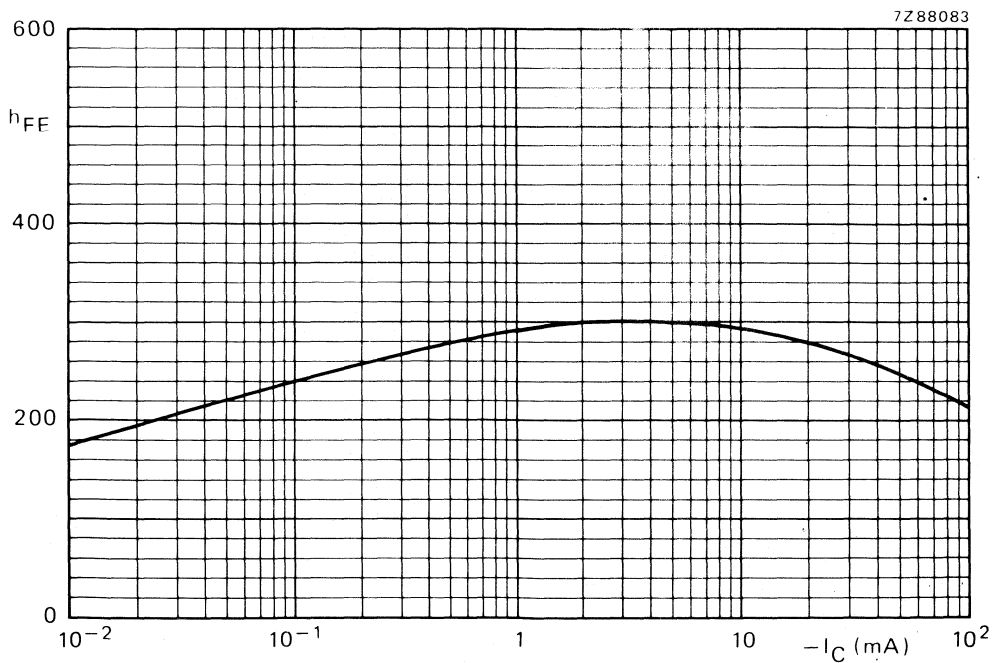

Fig. 7 Typical values D.C. current gain B-selections. $-V_{CE} = 5$ V; $T_j = 25$ °C.

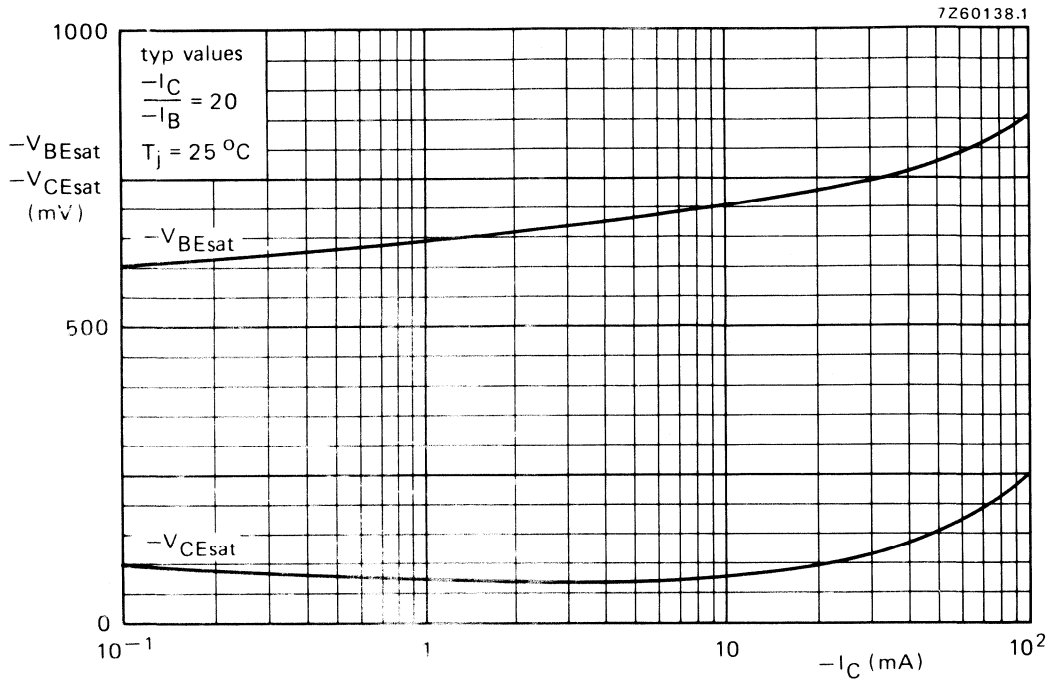

Fig. 8 Typical values base-emitter and collector-emitter saturation voltage.

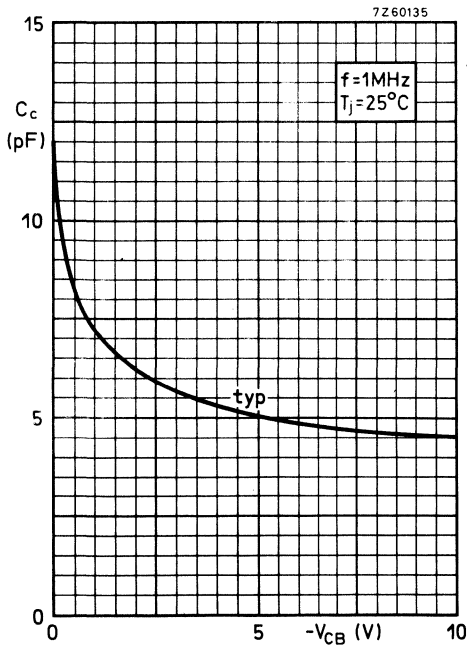

Fig. 9 Typical values.

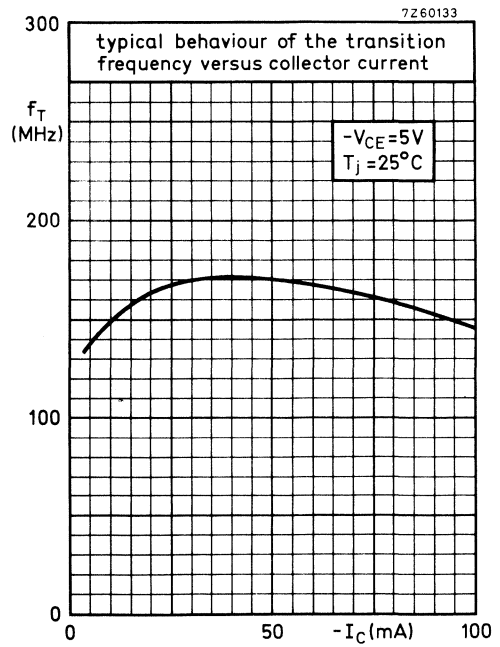

Fig. 10 Typical values. $f = 35\text{MHz}$.

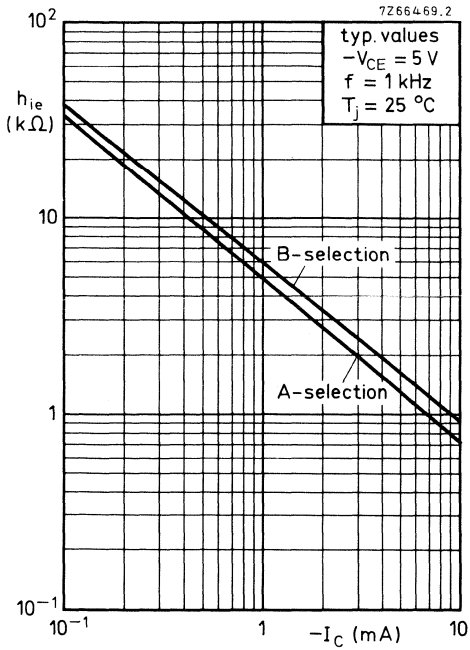

Fig. 11.

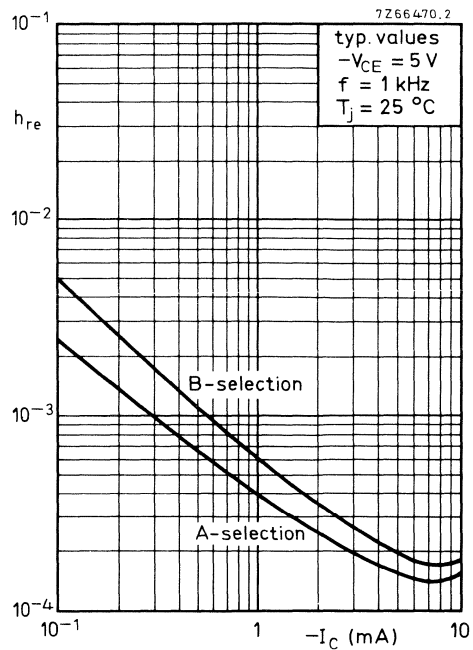

Fig. 12.

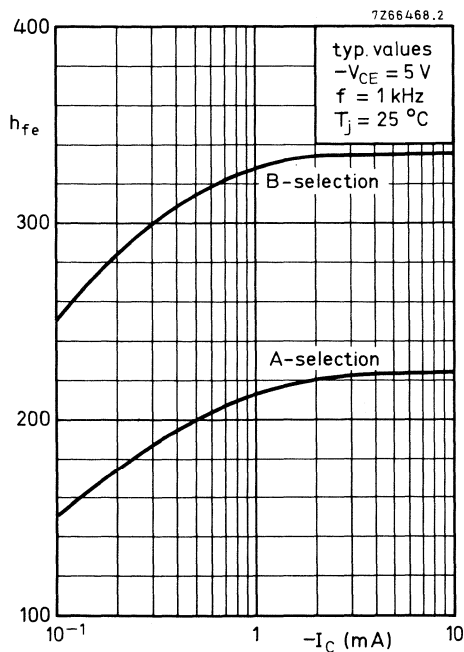

Fig. 13.

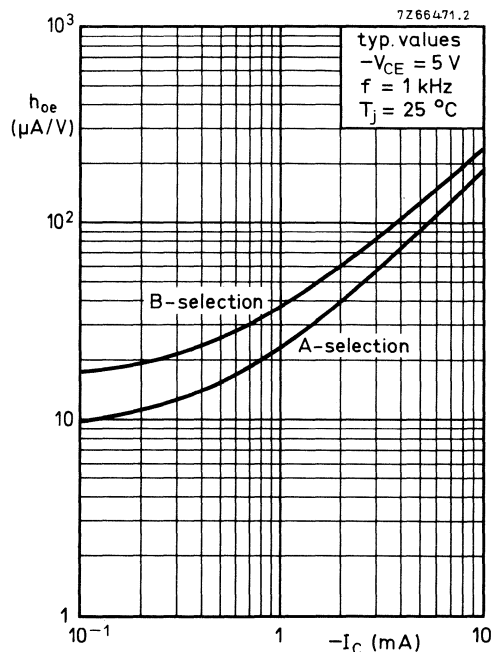

Fig. 14.

SILICON PLANAR EPITAXIAL TRANSISTORS

P-N-P transistors in a plastic SOT-23 envelope, primarily intended for low-noise input stages in tape recorders, hi-fi amplifiers and other audio frequency equipment in thick and thin-film hybrid circuits.

QUICK REFERENCE DATA

		BC859	BC860	
Collector-emitter voltage (+ $V_{BE} = 1\text{ V}$)	$-V_{CEX}$ max.	30	50	V
Collector-emitter voltage (open base)	$-V_{CEO}$ max.	30	45	V
Collector current (peak value)	$-I_{CM}$ max.	200	200	mA
Total power dissipation up to $T_{amb} = 60\text{ }^{\circ}\text{C}$	P_{tot} max.	200	200	mW
Junction temperature	T_j max.	150	150	$^{\circ}\text{C}$
Small-signal current gain	h_{fe}	> 125 < 900	125 900	
- $I_C = 2\text{ mA}$; $-V_{CE} = 5\text{ V}$; $f = 1\text{ kHz}$				
Transition frequency	f_T	typ. 150	150	MHz
- $I_C = 10\text{ mA}$; $-V_{CE} = 5\text{ V}$				
Noise figure at $R_s = 2\text{ k}\Omega$	F	typ. 1,2 < 4	1 3	dB
- $I_C = 200\text{ }\mu\text{A}$; $-V_{CE} = 5\text{ V}$ $f = 30\text{ Hz to }15\text{ kHz}$				
$f = 1\text{ kHz}$; $B = 200\text{ Hz}$				
	F	< 4	4	dB

MECHANICAL DATA

Fig. 1 SOT-23.

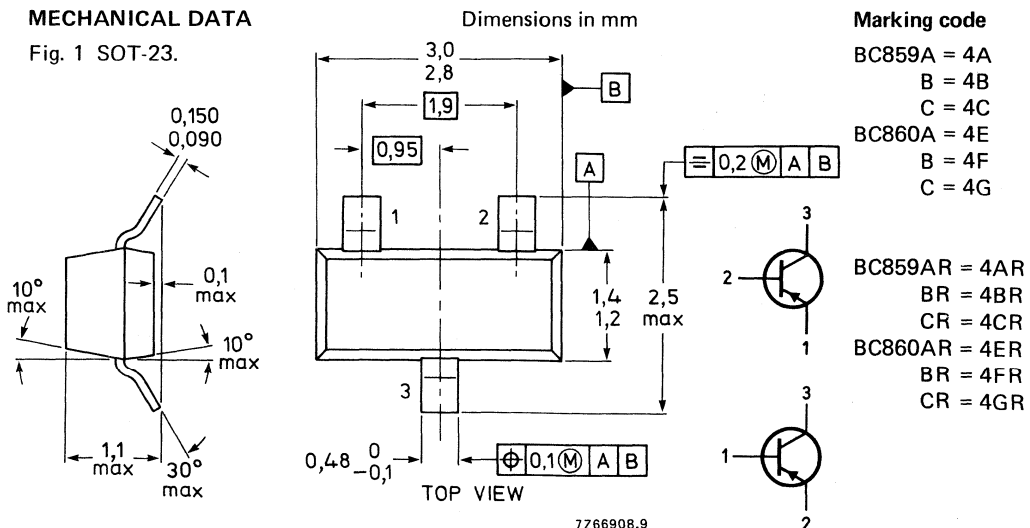

R-types are available on request

See also *Soldering recommendations*.

RATINGS

Limiting values in accordance with the Absolute Maximum System (IEC 134)

		BC859	BC860	
Collector-base voltage (open emitter)	$-V_{CBO}$ max.	30	50	V
Collector-emitter voltage (+ $V_{BE} = 1$ V)	$-V_{CEX}$ max.	30	50	V
Collector-emitter voltage (open base)	$-V_{CEO}$ max.	30	45	V
Emitter-base voltage (open collector)	$-V_{CBO}$ max.	5	5	V
Collector current (d.c.)	$-I_C$ max.	100		mA
Collector current (peak value)	$-I_{CM}$ max.	200		mA
Emitter current (peak value)	I_{EM} max.	200		mA
Base current (peak value)	$-I_{BM}$ max.	200		mA
Total power dissipation up to $T_{amb} = 60$ °C**	P_{tot} max.	200		mW
Storage temperature	T_{stg}	-65 to + 150		°C
Junction temperature	T_j max.	150		°C

THERMAL CHARACTERISTICS*

$$T_j = P_x (R_{th\ j-t} + R_{th\ t-s} + R_{th\ s-a}) + T_{amb}$$

Thermal resistance

From junction to tab	$R_{th\ j-t} =$	60	K/W
From tab to soldering points	$R_{th\ t-s} =$	280	K/W
From soldering points to ambient**	$R_{th\ s-a} =$	90	K/W

CHARACTERISTICS

$T_j = 25$ °C unless otherwise specified

Collector cut-off current

$I_E = 0; -V_{CB} = 30$ V; $T_j = 25$ °C	$-I_{CBO}$ typ.	1	nA
	$-I_{CBO} <$	15	nA
$T_j = 150$ °C	$-I_{CBO} <$	4	μA

Base-emitter voltage ▲

$-I_C = 2$ mA; $-V_{CE} = 5$ V	$-V_{BE}$ typ.	650	mV
$-I_C = 10$ mA; $-V_{CE} = 5$ V	$-V_{BE} <$	600 to 750	mV
		820	mV

* See *Thermal characteristics*.

** Mounted on a ceramic substrate of 8 mm x 10 mm x 0,7 mm.

▲ $-V_{BE}$ decreases by about 2 mV/K with increasing temperature.

Saturation voltages*

$-I_C = 10 \text{ mA}; -I_B = 0,5 \text{ mA}$

$-V_{CEsat}$	typ.	75	mV
	<	300	mV
$-V_{BEsat}$	typ.	700	mV

$-I_C = 100 \text{ mA}; -I_B = 5 \text{ mA}$

$-V_{CEsat}$	typ.	250	mV
	<	650	mV
$-V_{BEsat}$	typ.	850	mV

Collector capacitance at $f = 1 \text{ MHz}$

$I_E = I_e = 0; -V_{CB} = 10 \text{ V}$

C_c	typ.	4,5	pF
-------	------	-----	----

Transition frequency at $f = 35 \text{ MHz}$

$-I_C = 10 \text{ mA}; -V_{CE} = 5 \text{ V}$

f_T	typ.	150	MHz
-------	------	-----	-----

Small-signal current gain at $f = 1 \text{ kHz}$

$-I_C = 2 \text{ mA}; -V_{CE} = 5 \text{ V}$

h_{fe}		125 to 900	
----------	--	------------	--

Noise figure at $R_S = 2 \text{ k}\Omega$

$-I_C = 200 \mu\text{A}; -V_{CE} = 5 \text{ V}$

$f = 30 \text{ Hz to } 15 \text{ kHz}$

		BC859	BC860	
F	typ.	1,2	1	dB
	<	4	3	dB

$f = 1 \text{ kHz}; B = 200 \text{ Hz}$

F	typ.	1	1	dB
	<	4	4	dB

Equivalent noise voltage at $R_S = 2 \text{ k}\Omega$

$-I_C = 200 \mu\text{A}; -V_{CE} = 5 \text{ V}$

$f = 10 \text{ Hz to } 50 \text{ Hz}; T_{amb} = 25 \text{ }^\circ\text{C}$

V_n	<	—	0,11	μV
-------	---	---	------	---------------

D.C. current gain

$-I_C = 2 \text{ mA}; -V_{CE} = 5 \text{ V}; \text{ total range}$

A selections

B selections

C selections

h_{FE}		125 to 800
h_{FE}		125 to 250
h_{FE}		220 to 475
h_{FE}		420 to 800

* $-V_{BEsat}$ decreases by about 1,7 mV/K with increasing temperature.

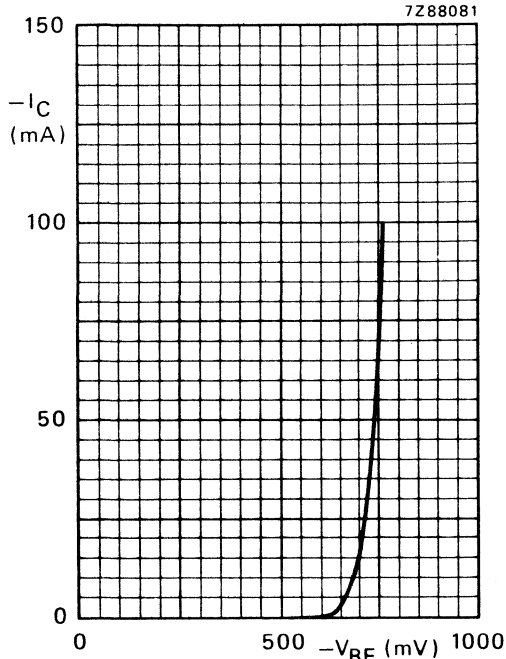

Fig. 3 Typical values. $-V_{CE} = 5 \text{ V}$; $T_j = 25 \text{ }^\circ\text{C}$.

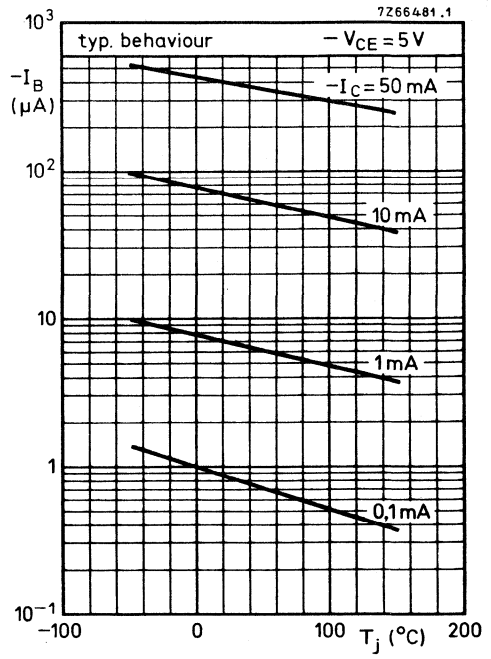

Fig. 4 Typical values.

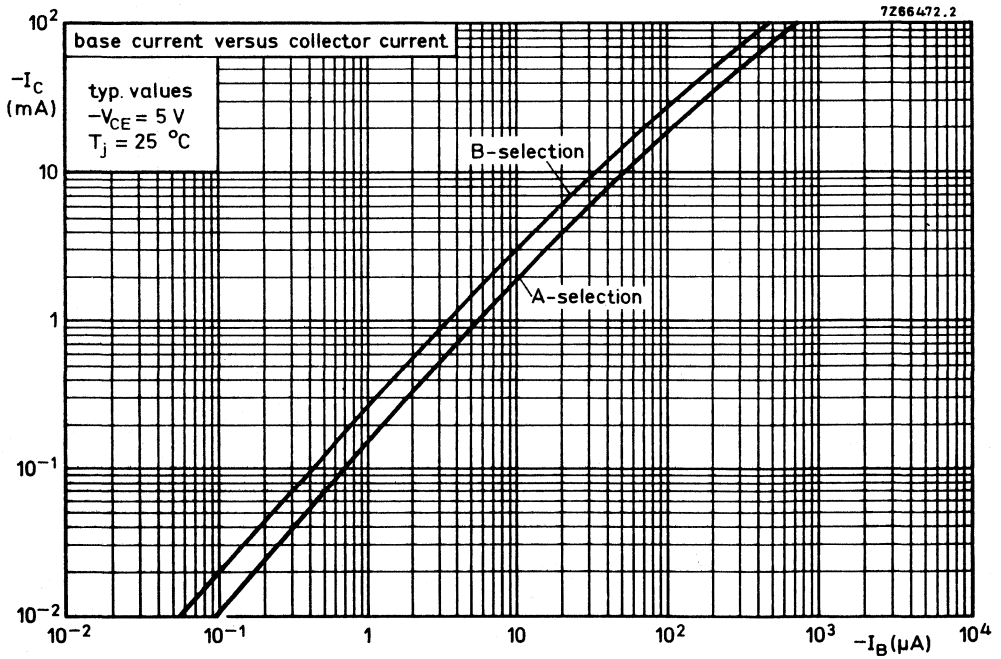

Fig. 5.

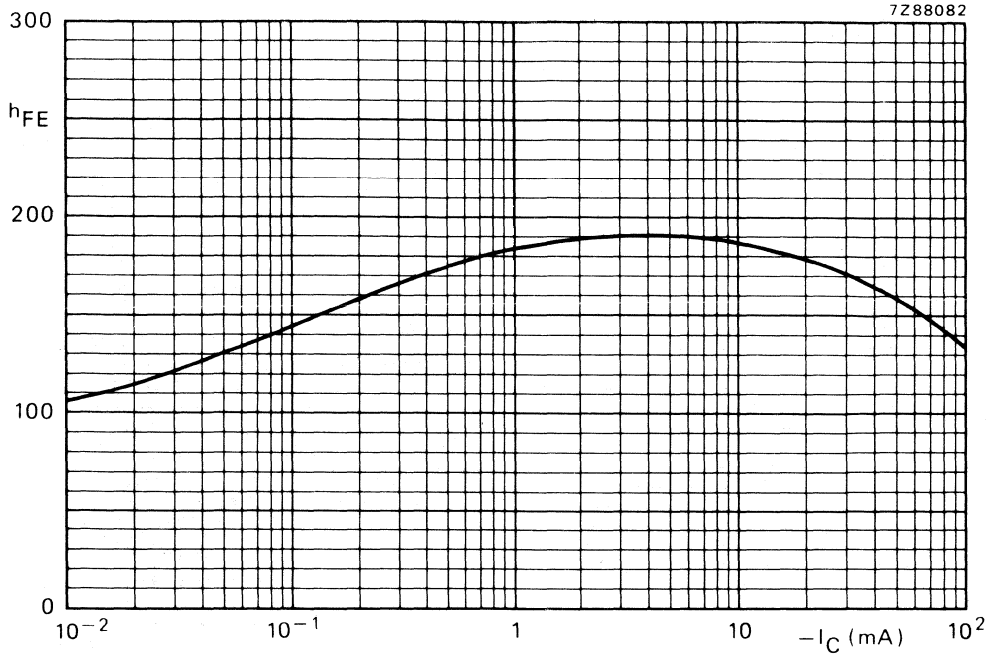

Fig. 6 Typical values. D.C. current gain A-selections. $-V_{CE} = 5$ V; $T_j = 25$ °C.

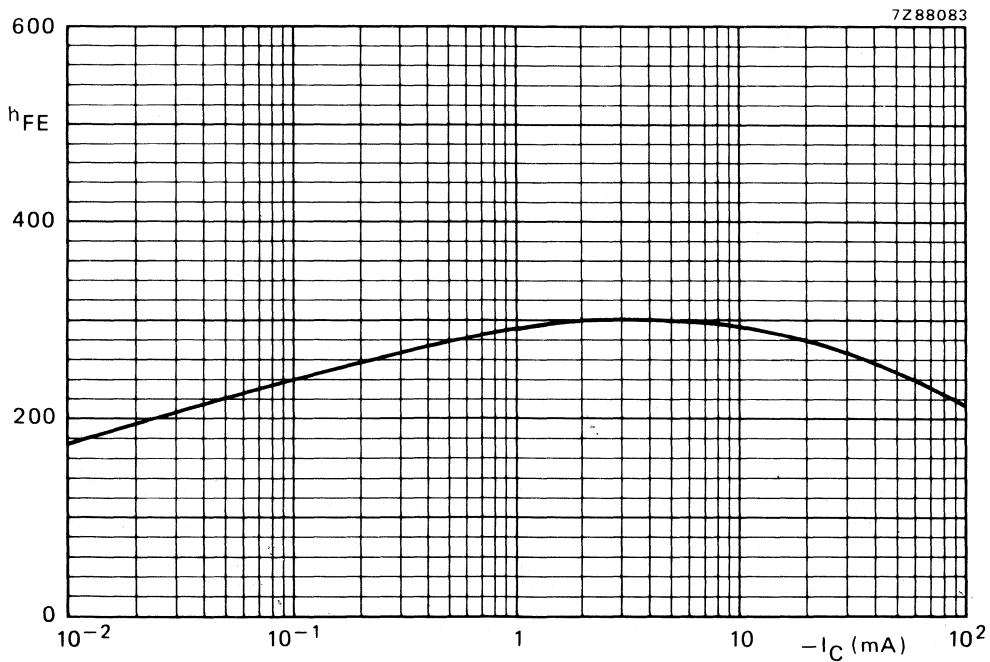

Fig. 7 Typical values. D.C. current gain B-selections. $-V_{CE} = 5$ V; $T_j = 25$ °C.

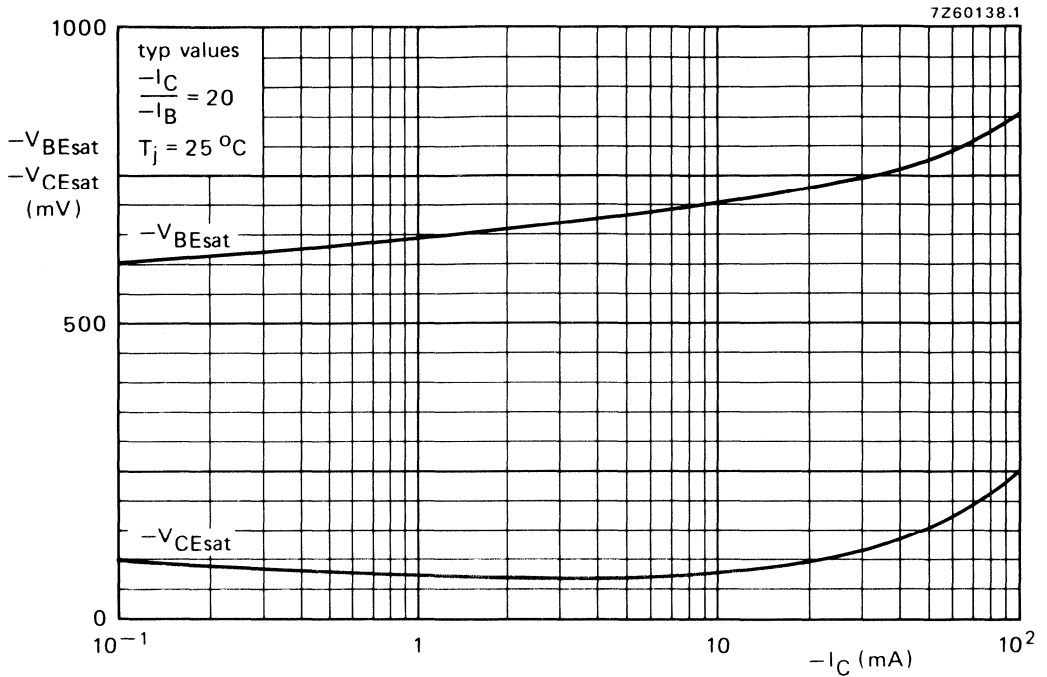

Fig. 8 Typical values base-emitter and collector-emitter saturation voltage.

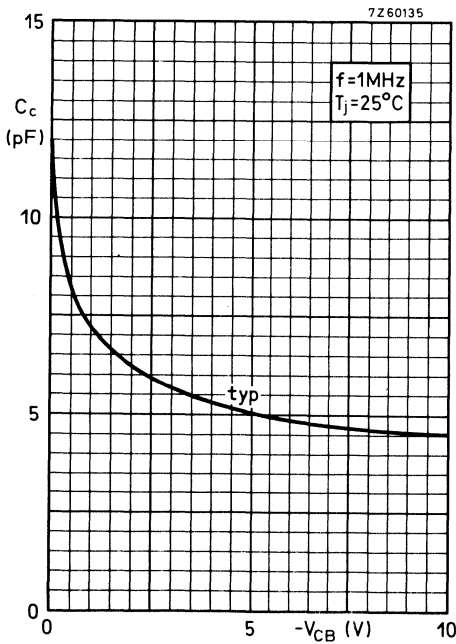

Fig. 9 Typical values.

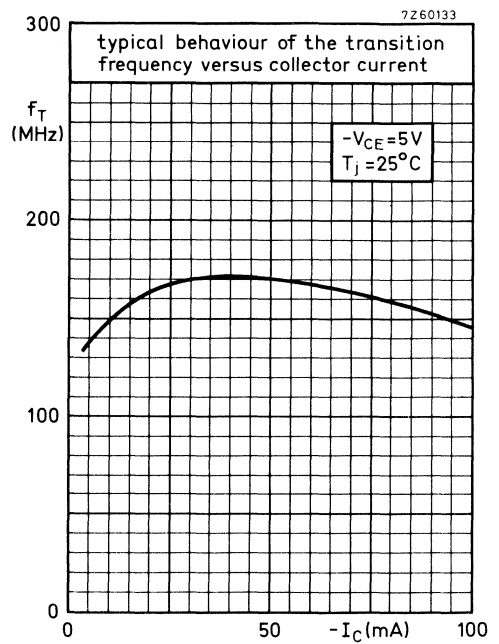

Fig. 10 Typical values. $f = 35$ MHz.

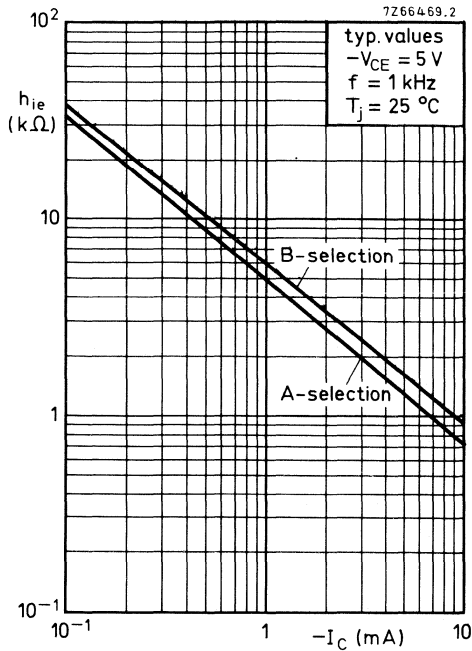

Fig. 11 Typical values.

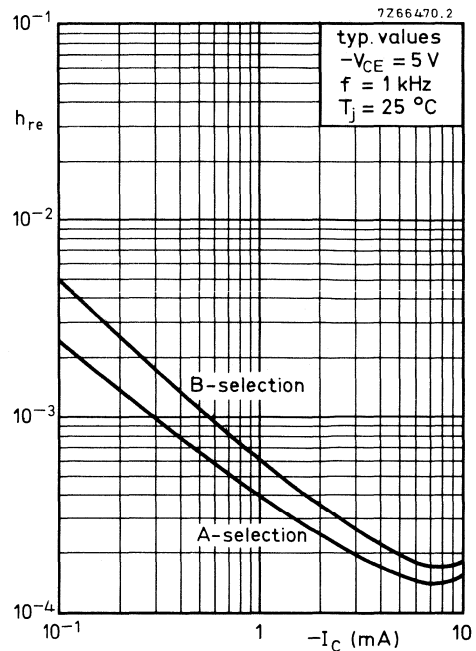

Fig. 12 Typical values.

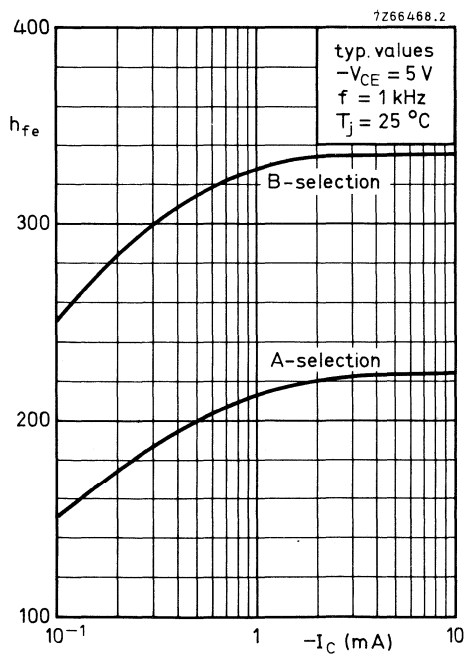

Fig. 13 Typical values.

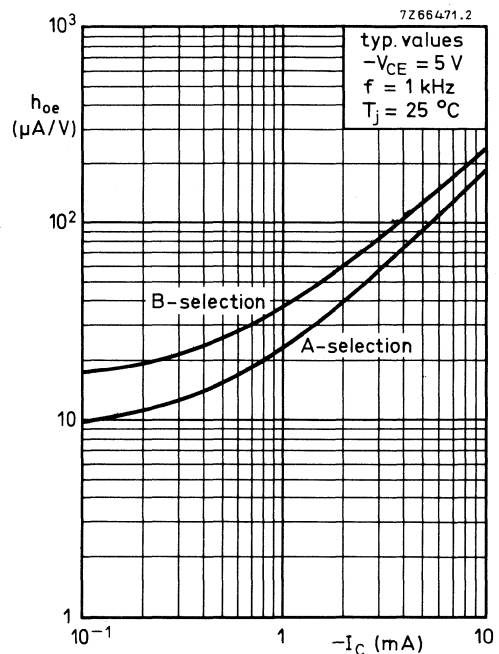

Fig. 14 Typical values.

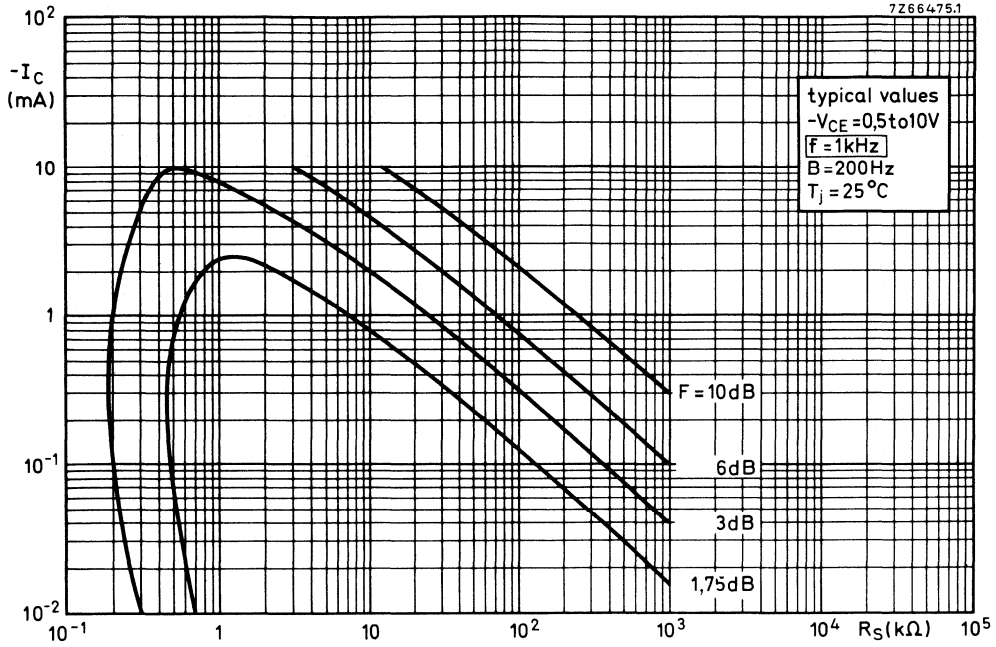

Fig. 15 Curves of constant noise figure at $f = 1$ kHz.

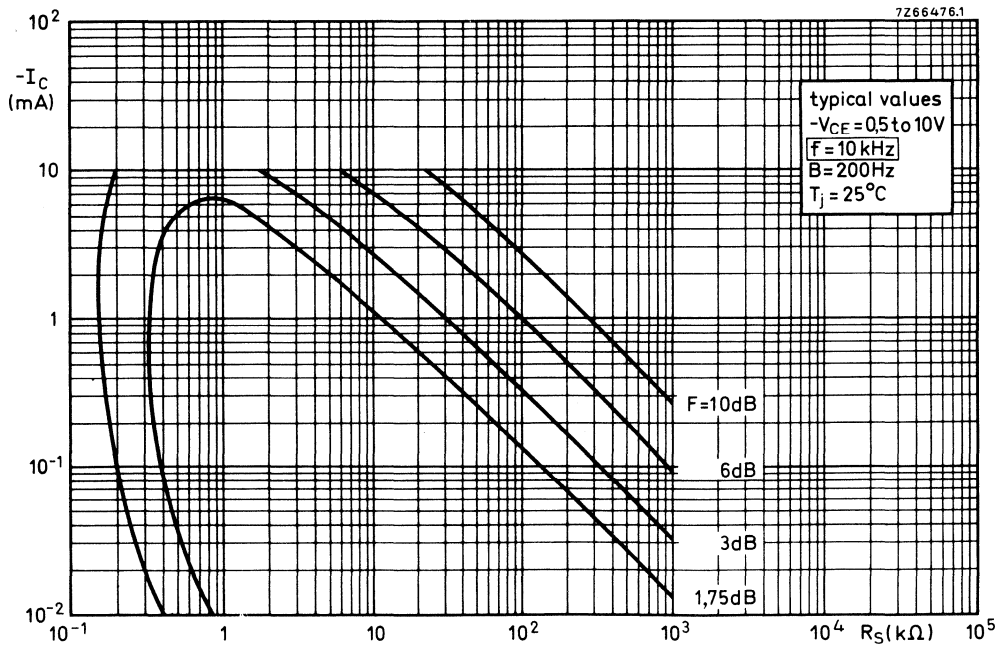

Fig. 16 Curves of constant noise figure at $f = 10$ kHz.

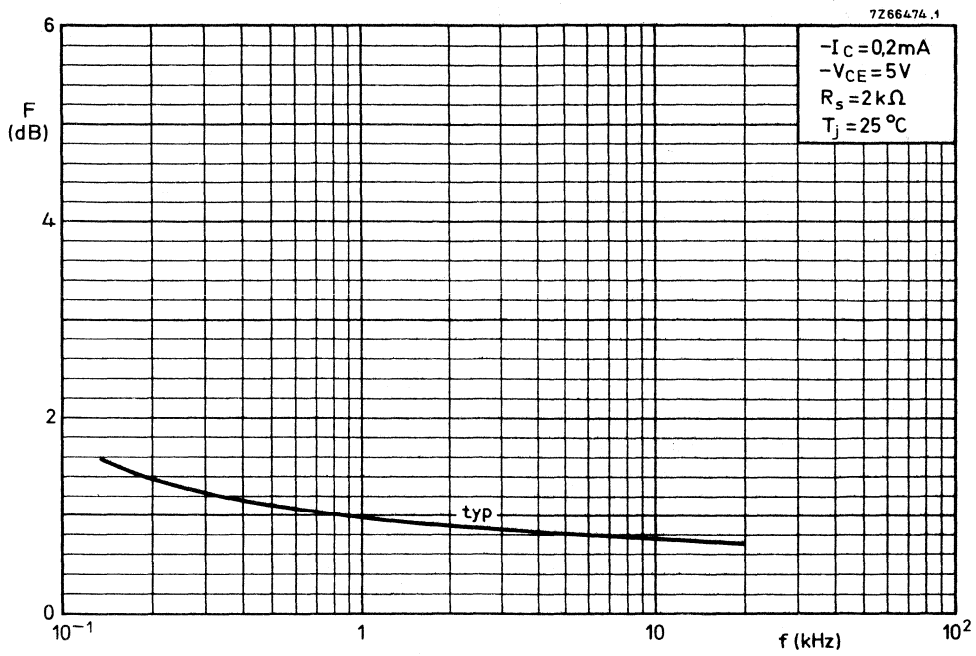

Fig. 17 Typical values noise figure.

SILICON PLANAR EPITAXIAL TRANSISTOR

N-P-N transistor in a microminiature plastic envelope intended for low-voltage, high-current l.f. applications. BC868/BC869 is the matched complementary pair suitable for class-B audio output stages up to 3 W.

QUICK REFERENCE DATA

Collector-emitter voltage ($V_{BE} = 0$)	V_{CES}	max.	25 V
Collector-emitter voltage (open base)	V_{CEO}	max.	20 V
Collector current (peak value)	I_{CM}	max.	2 A
Total power dissipation up to $T_{amb} = 25\text{ }^{\circ}\text{C}$	P_{tot}	max.	1 W
Junction temperature	T_j	max.	150 $^{\circ}\text{C}$
D.C. current gain	h_{FE}		85 to 375
$I_C = 500\text{ mA}; V_{CE} = 1\text{ V}$			
Transition frequency at $f = 35\text{ MHz}$	f_T	typ.	60 MHz
$I_C = 10\text{ mA}; V_{CE} = 5\text{ V}$			

MECHANICAL DATA

Dimensions in mm

Mark

Fig. 1 SOT-89.

CAC

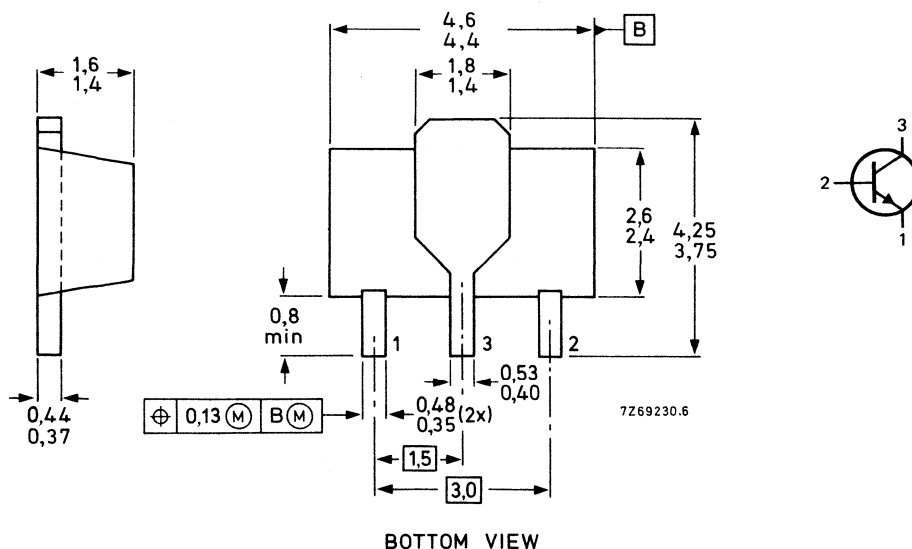

See also *Soldering recommendations*.

RATINGS

Limiting values in accordance with the Absolute Maximum System (IEC 134)

Collector-emitter voltage ($V_{BE} = 0$)	V_{CES}	max.	25 V
Collector-emitter voltage (open base)	V_{CEO}	max.	20 V
Emitter-base voltage (open collector)	V_{EBO}	max.	5 V
Collector current (d.c.)	I_C	max.	1 A
Collector current (peak value)	I_{CM}	max.	2 A
Base current (d.c.)	I_B	max.	100 mA
Base current (peak value)	I_{BM}	max.	200 mA
Total power dissipation up to $T_{amb} = 25\text{ }^\circ\text{C}^*$	P_{tot}	max.	1 W
Storage temperature	T_{stg}		-65 to + 150 $^\circ\text{C}$
Junction temperature	T_j	max.	150 $^\circ\text{C}$

THERMAL RESISTANCE

From junction to ambient in free air*	$R_{th\ j-a}$	=	125 K/W
From junction to tab	$R_{th\ j-t}$	=	10 K/W

CHARACTERISTICS

 $T_j = 25\text{ }^\circ\text{C}$ unless otherwise specified

Collector cut-off current $I_E = 0; V_{CB} = 25\text{ V}$	I_{CBO}	<	10 μA
$I_E = 0; V_{CB} = 25\text{ V}; T_j = 150\text{ }^\circ\text{C}$	I_{CBO}	<	1 mA
Emitter cut-off current $I_C = 0; V_{EB} = 5\text{ V}$	I_{EBO}	<	10 μA
Base-emitter voltage $I_C = 5\text{ mA}; V_{CE} = 10\text{ V}$	V_{BE}	typ.	0,62 V
$I_C = 1\text{ A}; V_{CE} = 1\text{ V}$	V_{BE}	<	1 V
Collector-emitter saturation voltage $I_C = 1\text{ A}; I_B = 100\text{ mA}$	V_{CEsat}	<	0,5 V
D.C. current gain $I_C = 5\text{ mA}; V_{CE} = 10\text{ V}$	h_{FE}	>	50
$I_C = 500\text{ mA}; V_{CE} = 1\text{ V}$	h_{FE}		85 to 375
$I_C = 1\text{ A}; V_{CE} = 1\text{ V}$	h_{FE}	>	60
Collector capacitance at $f = 450\text{ kHz}$ $I_E = I_e = 0; V_{CB} = 5\text{ V}$	C_C	typ.	27 pF
Transition frequency at $f = 35\text{ MHz}$ $I_C = 10\text{ mA}; V_{CE} = 5\text{ V}$	f_T	typ.	60 MHz

* Mounted on a ceramic substrate, area = 2,5 cm²; thickness = 0,7 mm.

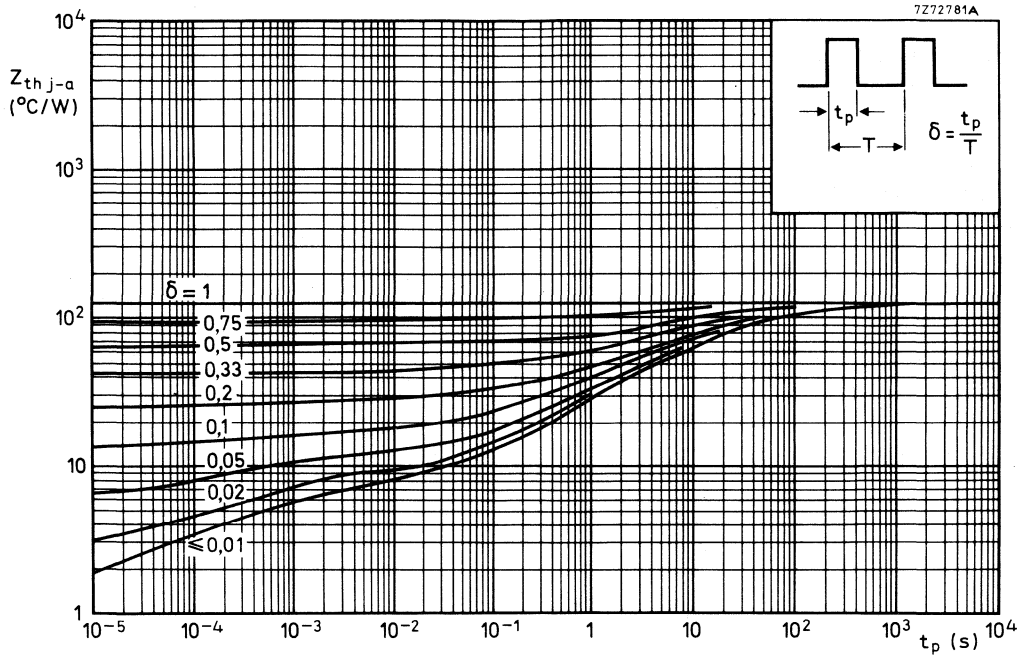

Fig. 2 Pulse power rating chart.

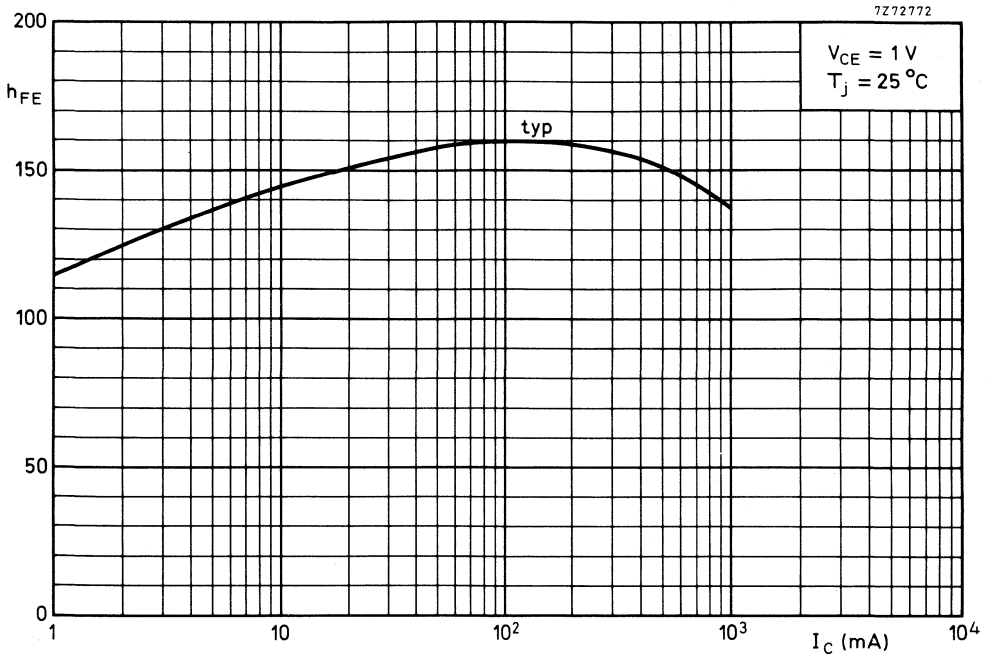

Fig. 3 D.C. current gain.

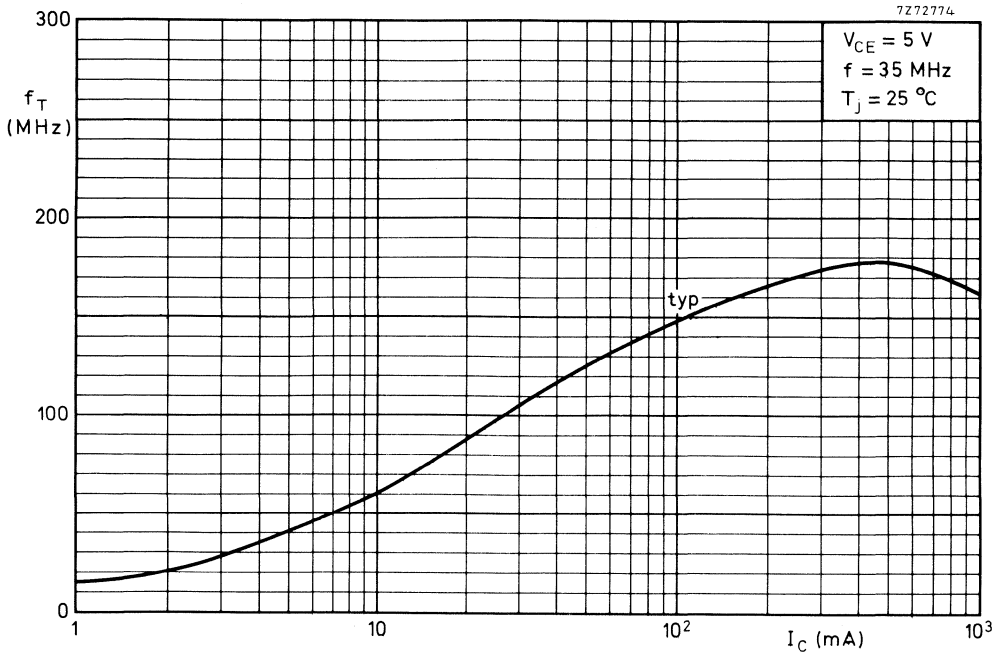

Fig. 4 Typical values transition frequency as a function of collector current.

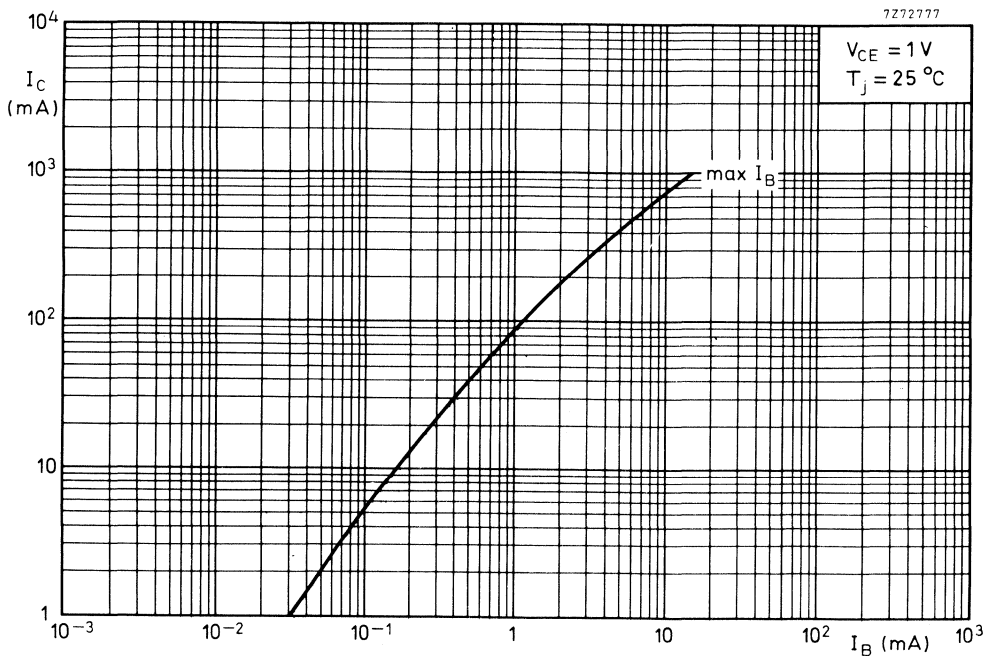

Fig. 5 Typical values collector current as a function of maximum base current.

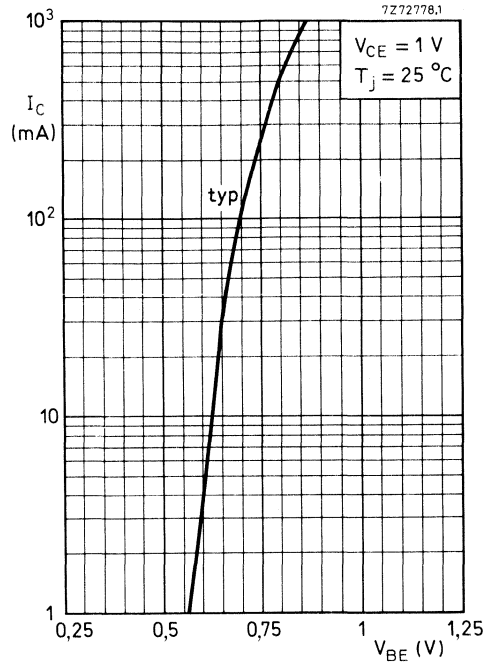

Fig. 6 Typical values collector current as a function of base-emitter voltage.

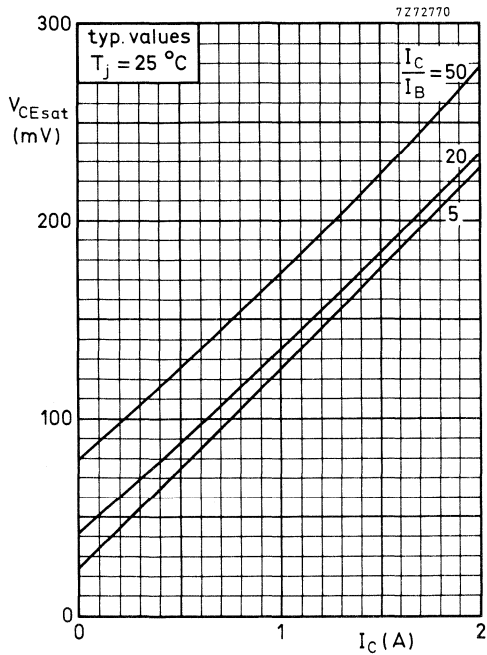

Fig. 7 Collector-emitter saturation voltage as a function of collector current.

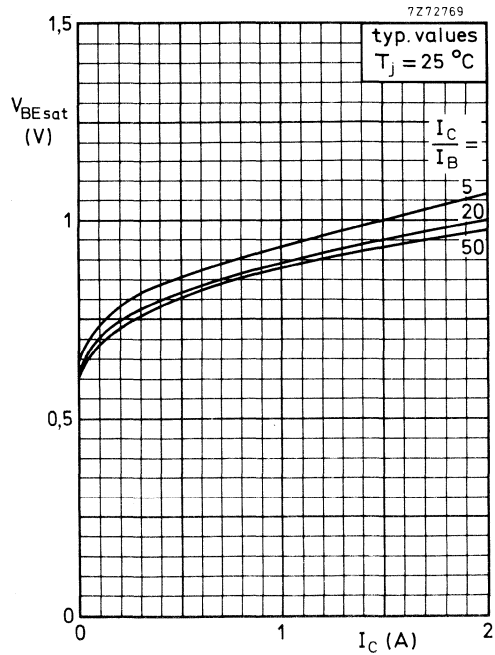

Fig. 8 Base-emitter saturation voltage as a function of collector current.

SILICON PLANAR EPITAXIAL TRANSISTOR

P-N-P transistor in a plastic microminiature envelope, intended for low-voltage, high-current I.f. applications. BC868/BC869 is the matched complementary pair suitable for class-B audio output stages up to 3 W.

QUICK REFERENCE DATA

Collector-emitter voltage ($V_{BE} = 0$)	$-V_{CES}$	max.	25 V
Collector-emitter voltage (open base)	$-V_{CEO}$	max.	20 V
Collector current (peak value)	$-I_{CM}$	max.	2 A
Total power dissipation up to $T_{amb} = 25\text{ }^{\circ}\text{C}$	P_{tot}	max.	1 W
Junction temperature	T_j	max.	150 $^{\circ}\text{C}$
D.C. current gain	h_{FE}		85 to 375
$-I_C = 500\text{ mA}; -V_{CE} = 1\text{ V}$			
Transition frequency at $f = 35\text{ MHz}$	f_T	typ.	60 MHz
$-I_C = 10\text{ mA}; -V_{CE} = 5\text{ V}$			

MECHANICAL DATA

Dimensions in mm

Mark

Fig. 1 SOT-89.

CEC

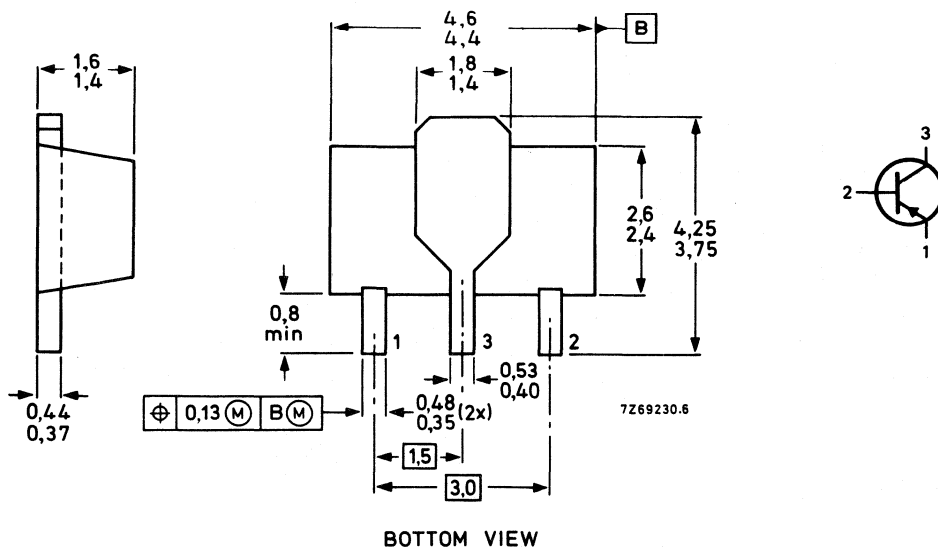

See also *Soldering recommendations*.

RATINGS

Limiting values in accordance with the Absolute Maximum System (IEC 134)

Collector-emitter voltage ($V_{BE} = 0$)	$-V_{CES}$	max.	25 V
Collector-emitter voltage (open base)	$-V_{CEO}$	max.	20 V
Emitter-base voltage (open collector)	$-V_{EBO}$	max.	5 V
Collector current (d.c.)	$-I_C$	max.	1 A
Collector current (peak value)	$-I_{CM}$	max.	2 A
Base current (d.c.)	$-I_B$	max.	100 mA
Base current (peak value)	$-I_{BM}$	max.	200 mA
Total power dissipation up to $T_{amb} = 25\text{ }^\circ\text{C}^*$	P_{tot}	max.	1 W
Storage temperature	T_{stg}		-65 to + 150 $^\circ\text{C}$
Junction temperature	T_j	max.	150 $^\circ\text{C}$

THERMAL RESISTANCE

From junction to ambient in free air*	$R_{th\ j-a}$	=	125 K/W
From junction to tab	$R_{th\ j-t}$	=	10 K/W

CHARACTERISTICS $T_j = 25\text{ }^\circ\text{C}$ unless otherwise specified

Collector cut-off current			
$I_E = 0; -V_{CB} = 25\text{ V}$	$-I_{CBO}$	<	10 μA
$I_E = 0; -V_{CB} = 25\text{ V}; T_j = 150\text{ }^\circ\text{C}$	$-I_{CBO}$	<	1 mA
Emitter cut-off current			
$I_C = 0; -V_{EB} = 5\text{ V}$	$-I_{EBO}$	<	10 μA
Base-emitter voltage			
$-I_C = 5\text{ mA}; -V_{CE} = 10\text{ V}$	$-V_{BE}$	typ.	0,62 V
$-I_C = 1\text{ A}; -V_{CE} = 1\text{ V}$	$-V_{BE}$	<	1 V
Collector-emitter saturation voltage			
$-I_C = 1\text{ A}; -I_B = 100\text{ mA}$	$-V_{CEsat}$	<	0,5 V
D.C. current gain			
$-I_C = 5\text{ mA}; -V_{CE} = 10\text{ V}$	h_{FE}	>	50
$-I_C = 500\text{ mA}; -V_{CE} = 1\text{ V}$	h_{FE}		85 to 375
$-I_C = 1\text{ A}; -V_{CE} = 1\text{ V}$	h_{FE}	>	60
Collector capacitance at $f = 450\text{ kHz}$			
$I_E = I_e = 0; -V_{CB} = 5\text{ V}$	C_C	typ.	45 pF
Transition frequency at $f = 35\text{ MHz}$			
$-I_C = 10\text{ mA}; -V_{CE} = 5\text{ V}$	f_T	typ.	60 MHz

* Mounted on a ceramic substrate, area = 2,5 cm²; thickness = 0,7 mm.

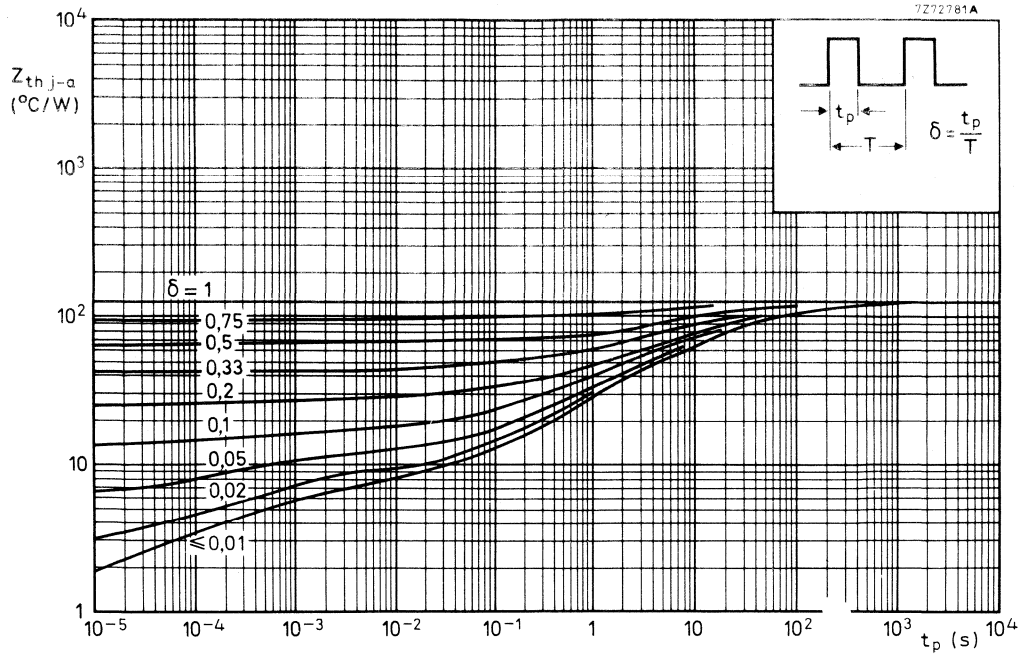

Fig. 2 Pulse power rating chart.

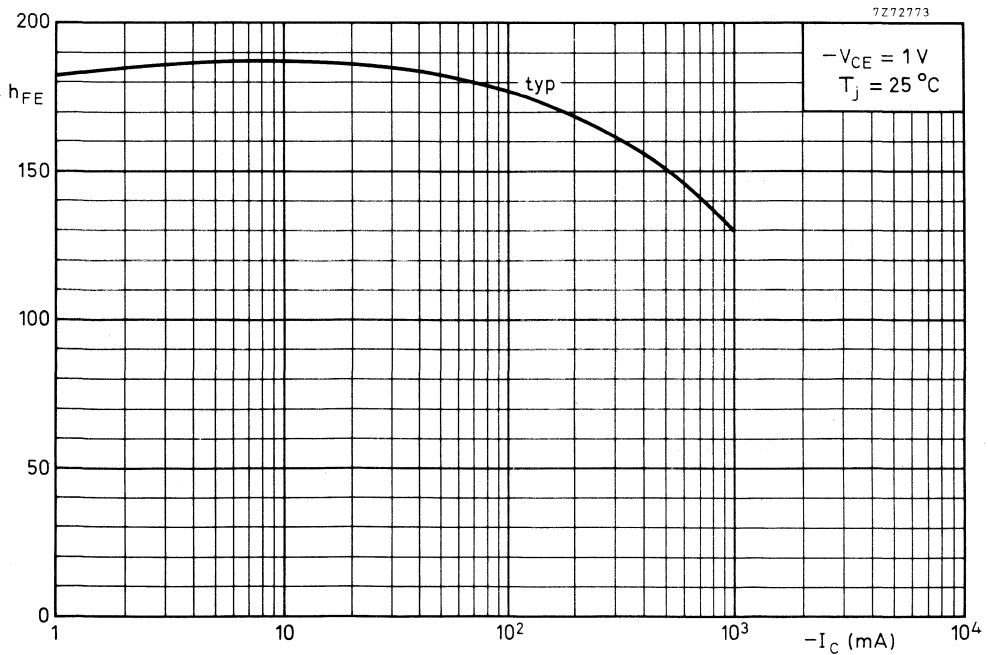

Fig. 3 D.C. current gain.

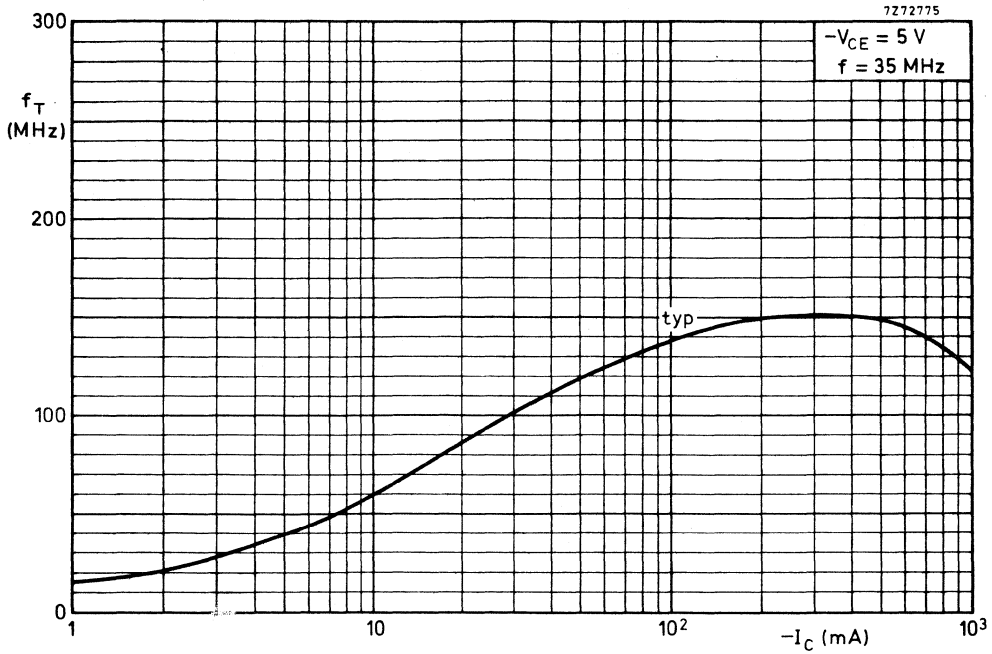

Fig. 4 Typical values transition frequency as a function of collector current.

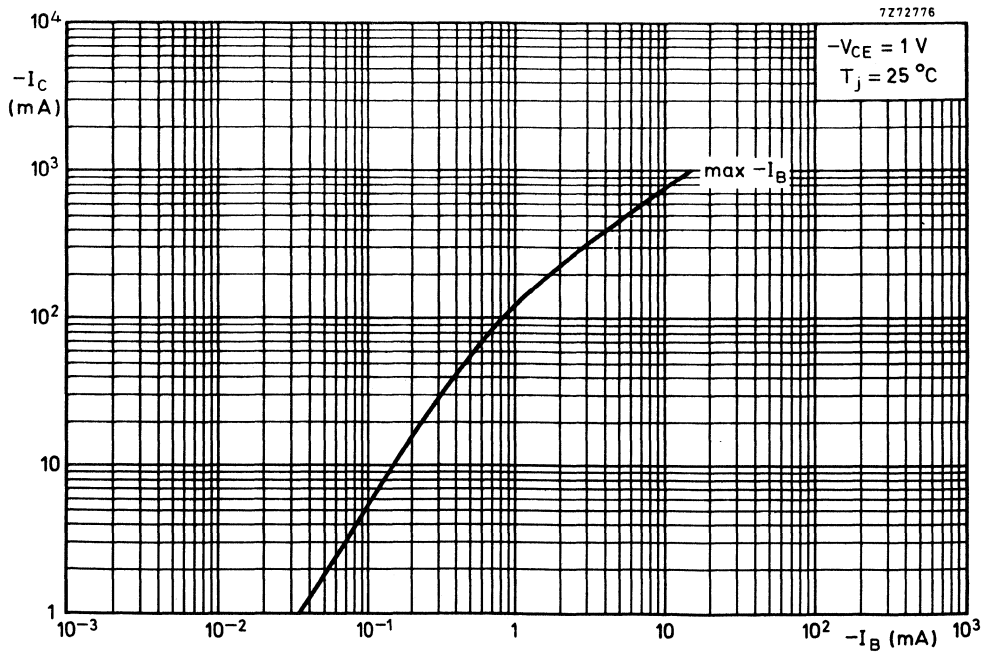

Fig. 5 Typical values collector current as a function of maximum base current.

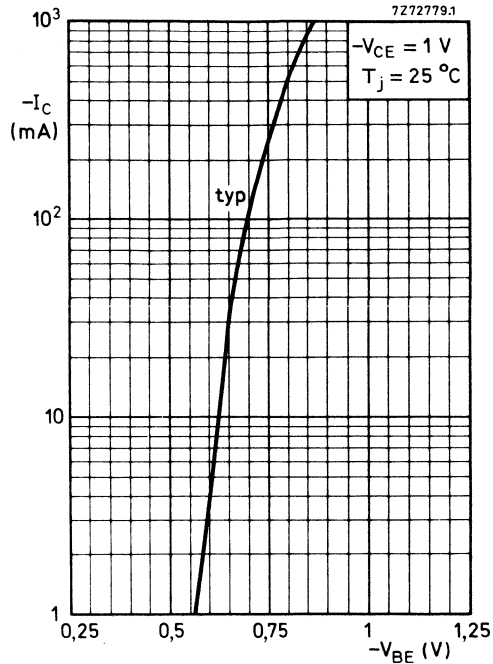

Fig. 6 Typical values collector current as a function of base-emitter voltage.

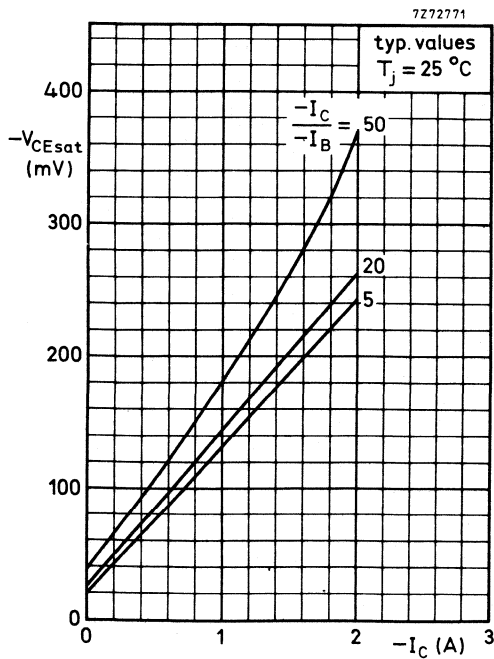

Fig. 7 Collector-emitter saturation voltage as a function of collector current.

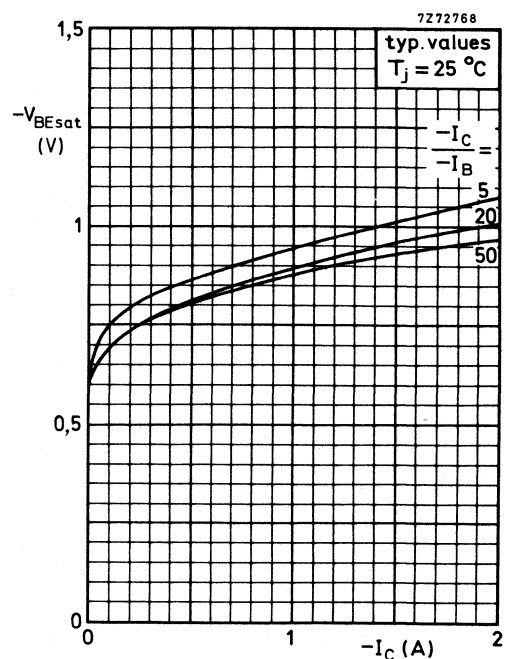

Fig. 8 Base-emitter saturation voltage as a function of collector current.

SILICON PLANAR EPITAXIAL TRANSISTORS

P-N-P transistors, in a microminiature plastic envelope, intended for low level, low noise general purpose applications in thick and thin-film circuits.

QUICK REFERENCE DATA

		BCF29	BCF30
D.C. current gain at $T_j = 25\text{ }^\circ\text{C}$ $-I_C = 2\text{ mA}; -V_{CE} = 5\text{ V}$	$h_{FE} >$	120	215
	$h_{FE} <$	260	500
Collector-base voltage (open emitter)	$-V_{CBO}$ max.	32	V
Collector-emitter voltage (open base)	$-V_{CEO}$ max.	32	V
Collector current (peak value)	$-I_{CM}$ max.	200	mA
Total power dissipation up to $T_{amb} = 25\text{ }^\circ\text{C}$	P_{tot} max.	350	mW
Junction temperature	T_j max.	175	$^\circ\text{C}$
Transition frequency at $f = 35\text{ MHz}$ $-I_C = 10\text{ mA}; -V_{CE} = 5\text{ V}$	f_T typ.	150	MHz
	Noise figure at $R_S = 2\text{ k}\Omega$ $-I_C = 200\text{ }\mu\text{A}; -V_{CE} = 5\text{ V};$ $f = 1\text{ kHz}; B = 200\text{ Hz}$	F <	4

MECHANICAL DATA

Fig. 1 SOT-23.

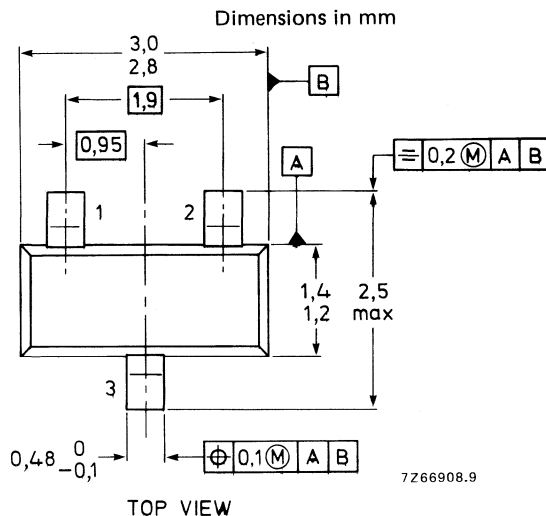
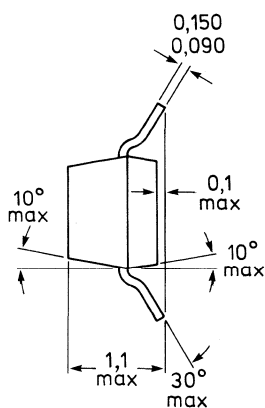

Marking code

BCF29 = C7
BCF30 = C8

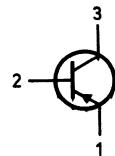

BCF29R = C77
BCF30R = C9

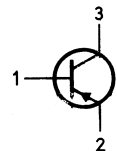

R-types are available on request.

See also *Soldering recommendations*.

RATINGS

Limiting values in accordance with the Absolute Maximum System (IEC 134)

Collector-base voltage (open emitter)	$-V_{CBO}$	max.	32 V
Collector-emitter voltage ($V_{BE} = 0$)	$-V_{CES}$	max.	32 V
Collector-emitter voltage (open base) $-I_C = 2 \text{ mA}$	$-V_{CEO}$	max.	32 V
Emitter-base voltage (open collector)	$-V_{EBO}$	max.	5 V
Collector current (d.c.)	$-I_C$	max.	100 mA
Collector current (peak value)	$-I_{CM}$	max.	200 mA
Total power dissipation up to $T_{amb} = 25 \text{ }^\circ\text{C}^{**}$	P_{tot}	max.	350 mW
Storage temperature	T_{stg}		-65 to + 175 $^\circ\text{C}$
Junction temperature	T_j	max.	175 $^\circ\text{C}$

THERMAL CHARACTERISTICS *

$$T_j = P \times (R_{th j-t} + R_{th t-s} + R_{th s-a}) + T_{amb}$$

Thermal resistance

From junction to tab	$R_{th j-t}$	=	50 K/W
From tab to soldering points	$R_{th t-s}$	=	280 K/W
From soldering points to ambient**	$R_{th s-a}$	=	90 K/W

CHARACTERISTICS

$T_j = 25 \text{ }^\circ\text{C}$ unless otherwise specified

Collector cut-off current

$$I_E = 0; -V_{CB} = 32 \text{ V} \quad -I_{CBO} < 100 \text{ nA}$$

$$I_E = 0; -V_{CB} = 32 \text{ V}; T_j = 100 \text{ }^\circ\text{C} \quad -I_{CBO} < 10 \text{ } \mu\text{A}$$

Base-emitter voltage

$$-I_C = 2 \text{ mA}; -V_{CE} = 5 \text{ V} \quad -V_{BE} \quad 600 \text{ to } 750 \text{ mV}$$

Saturation voltages

$$-I_C = 10 \text{ mA}; -I_B = 0,5 \text{ mA} \quad -V_{CEsat} \begin{matrix} \text{typ.} & 80 \text{ mV} \\ & < & 300 \text{ mV} \end{matrix}$$

$$-I_C = 50 \text{ mV}; -I_B = 2,5 \text{ mA} \quad -V_{BEsat} \text{ typ. } 720 \text{ mV}$$

$$-I_C = 50 \text{ mV}; -I_B = 2,5 \text{ mA} \quad -V_{CEsat} \text{ typ. } 150 \text{ mV}$$

$$-I_C = 50 \text{ mV}; -I_B = 2,5 \text{ mA} \quad -V_{BEsat} \text{ typ. } 810 \text{ mV}$$

* See *Thermal characteristics*.

** Mounted on a ceramic substrate of 8 mm x 10 mm x 0,7 mm.

D.C. current gain

$-I_C = 10 \mu\text{A}; -V_{CE} = 5 \text{ V}$

h_{FE}

	BCF29	BCF30
typ.	90	150
>	120	215
<	260	500

$-I_C = 2 \text{ mA}; -V_{CE} = 5 \text{ V}$

h_{FE}

Collector capacitance at $f = 1 \text{ MHz}$

$I_E = I_e = 0; -V_{CB} = 10 \text{ V}$

C_c

typ. 4,5 pF

Transition frequency at $f = 35 \text{ MHz}$

$-I_C = 10 \text{ mA}; -V_{CE} = 5 \text{ V}$

f_T

typ. 150 MHz

Noise figure at $R_S = 2 \text{ k}\Omega$

$-I_C = 200 \mu\text{A}; -V_{CE} = 5 \text{ V}$

F

< 4 dB
typ. 1 dB

$f = 1 \text{ kHz}; B = 200 \text{ Hz}$

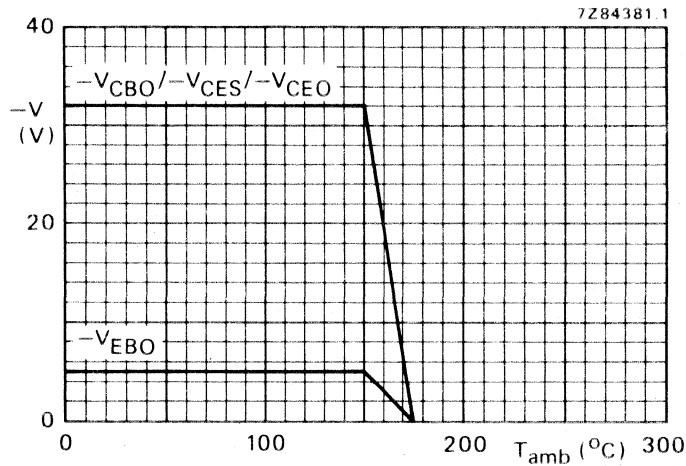

Fig. 2 Voltage derating curves.

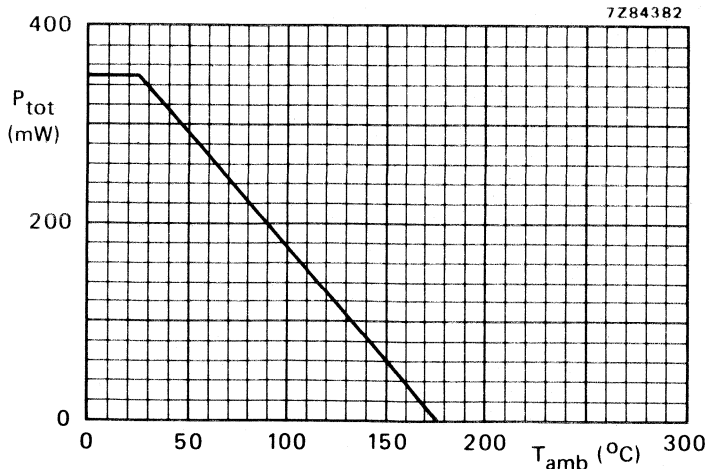

Fig. 3 Power derating curve.

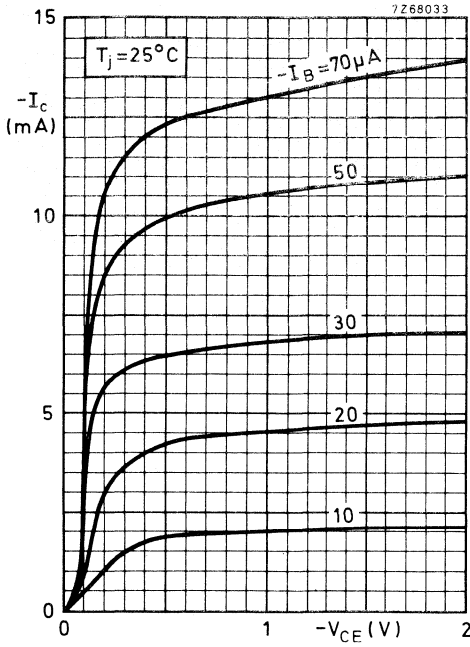

Fig. 4.

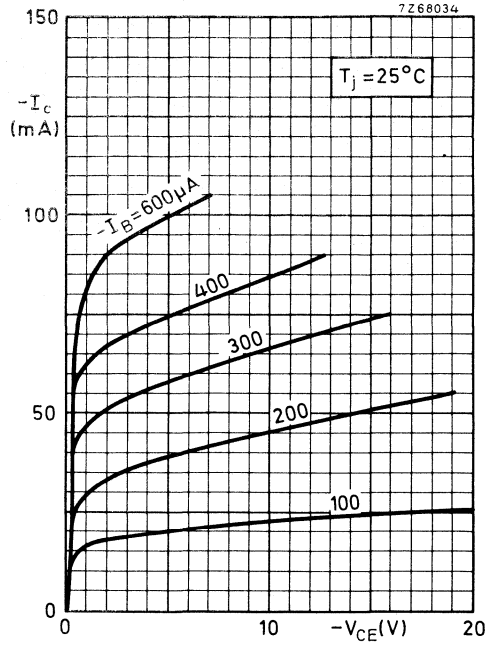

Fig. 5.

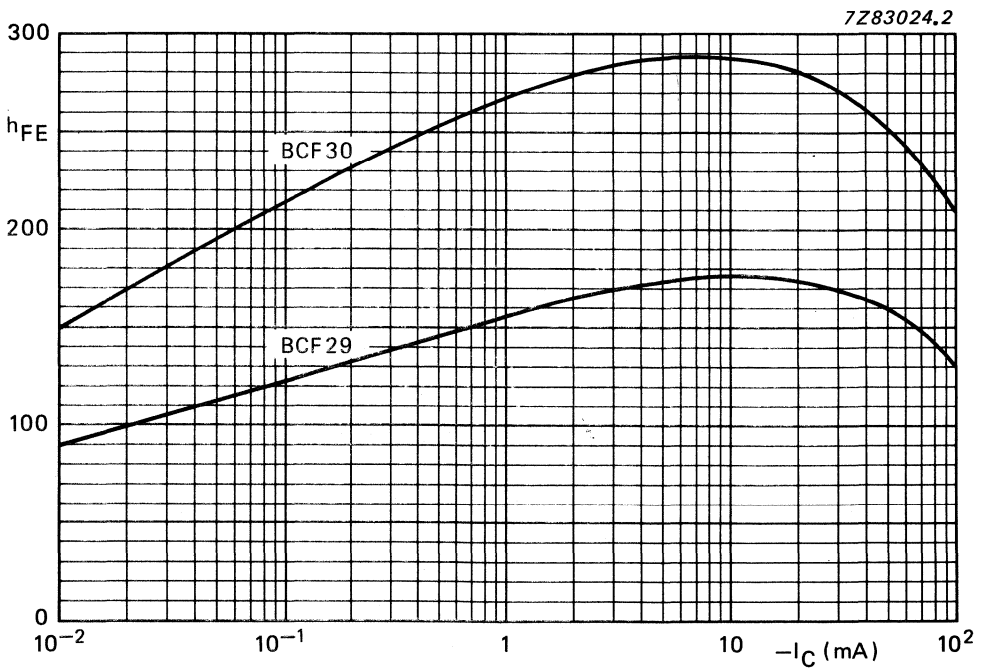
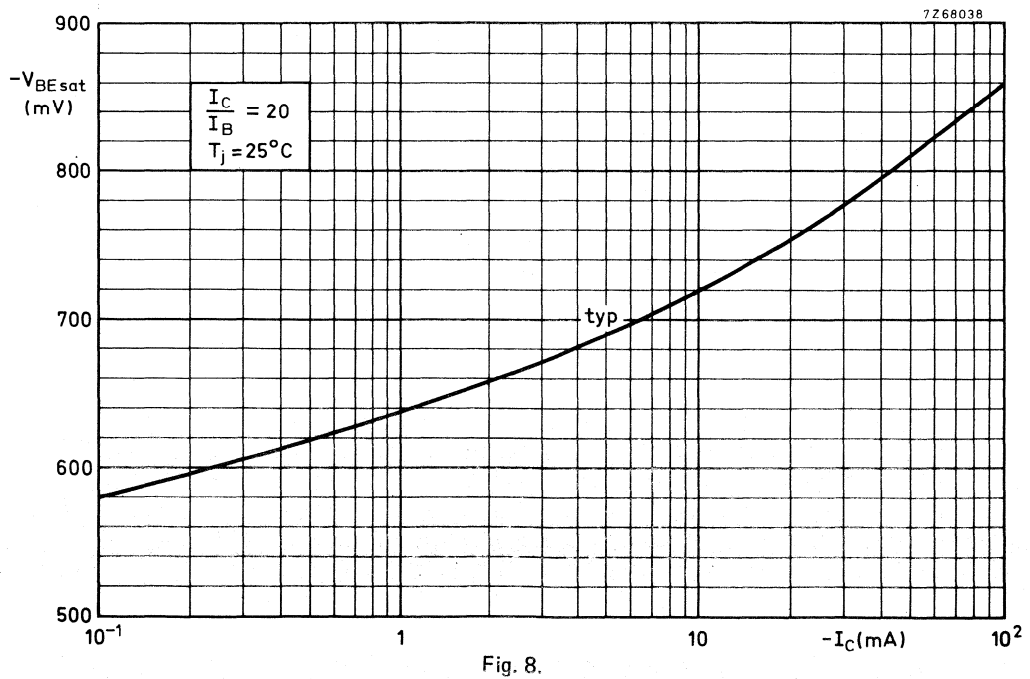
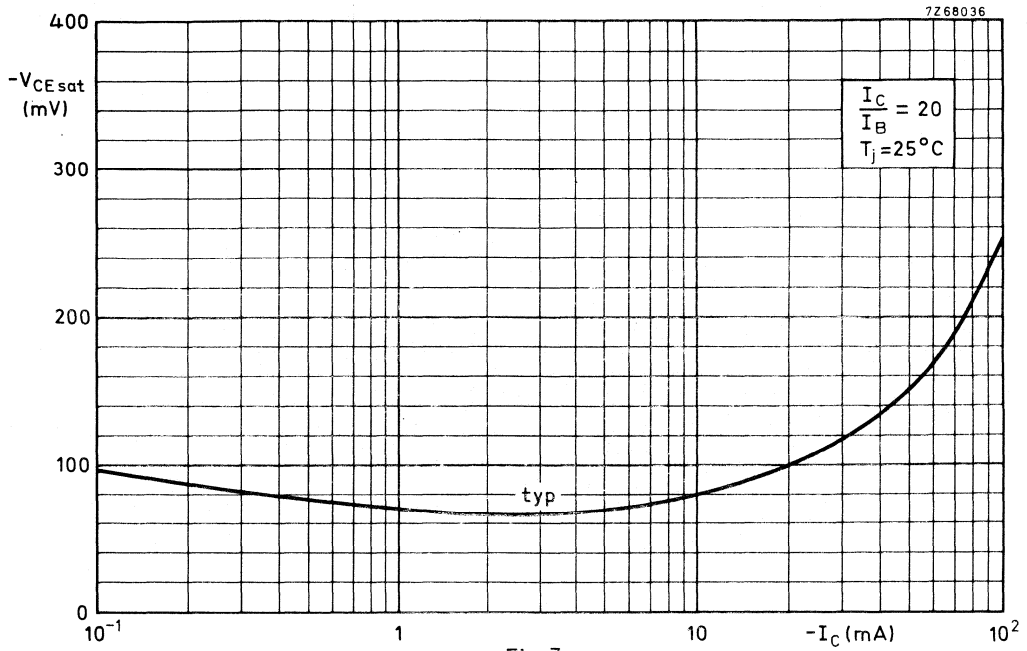

Fig. 6 Typical values of d.c. current gain. $-V_{CE} = 5\ \text{V}$; $T_j = 25^\circ\text{C}$.



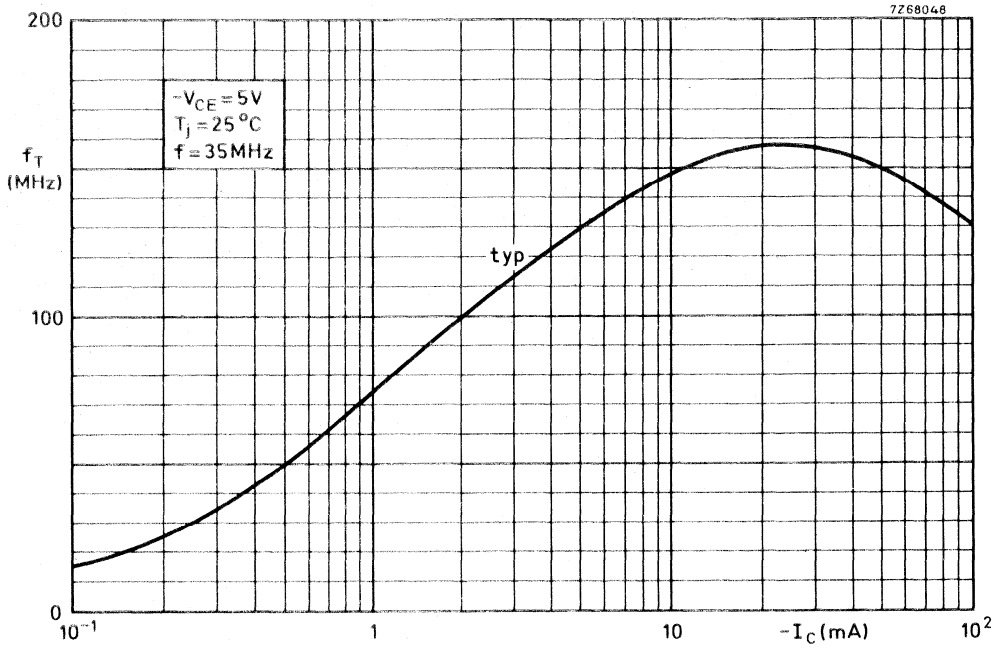

Fig. 9.

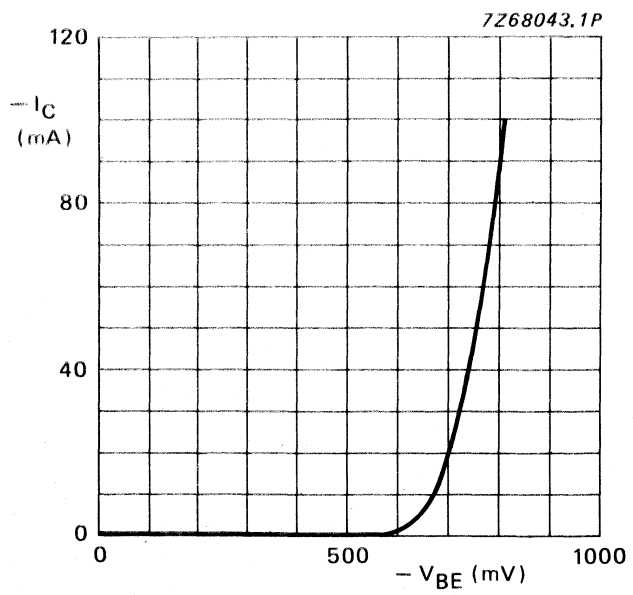

Fig. 10 $-V_{CE} = 5V$; $T_j = 25^\circ C$; typical values.

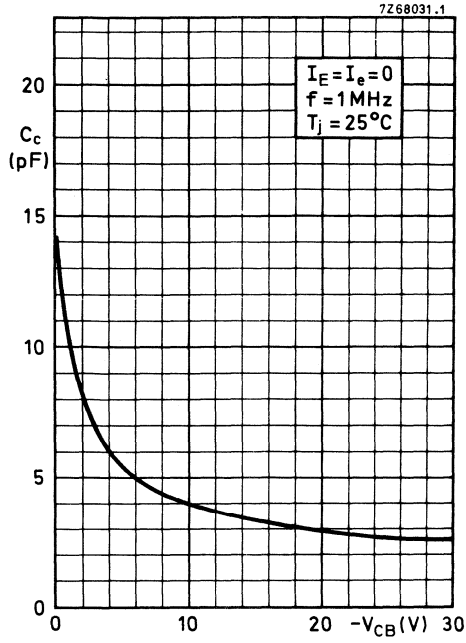

Fig. 11.

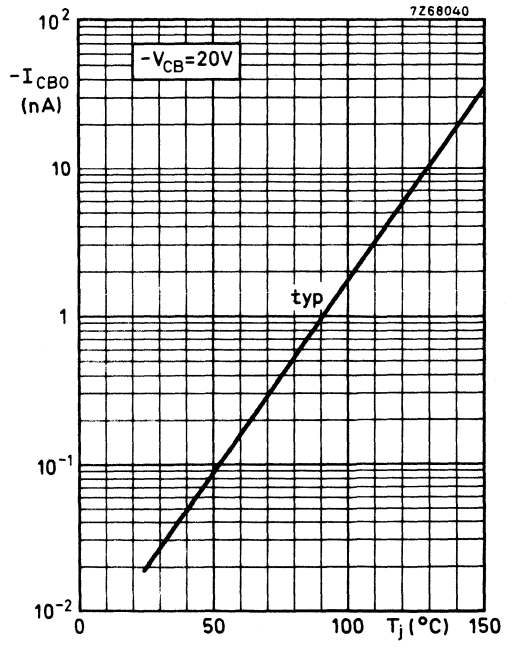

Fig. 12.

SILICON PLANAR EPITAXIAL TRANSISTORS

N-P-N transistors in a microminiature plastic envelope. They are intended for low level, low noise general purpose applications in thick and thin-film circuits.

QUICK REFERENCE DATA

		BCF32	BCF33
D.C. current gain at $T_j = 25\text{ }^\circ\text{C}$ $I_C = 2\text{ mA}; V_{CE} = 5\text{ V}$	$h_{FE} >$	200	420
	$h_{FE} <$	450	800
Collector-base voltage (open emitter)	V_{CBO} max.	32	V
Collector-emitter voltage (open base)	V_{CEO} max.	32	V
Collector current (peak value)	I_{CM} max.	200	mA
Total power dissipation up to $T_{amb} = 25\text{ }^\circ\text{C}$	P_{tot} max.	350	mW
Junction temperature	T_j max.	175	$^\circ\text{C}$
Transition frequency at $f = 35\text{ MHz}$ $I_C = 2\text{ mA}; V_{CE} = 5\text{ V}$	f_T typ.	300	MHz
Noise figure at $R_S = 2\text{ k}\Omega$ $I_C = 200\text{ }\mu\text{A}; V_{CE} = 5\text{ V};$ $f = 1\text{ kHz}; B = 200\text{ Hz}$	F	<	4 dB

MECHANICAL DATA

Fig. 1 SOT-23.

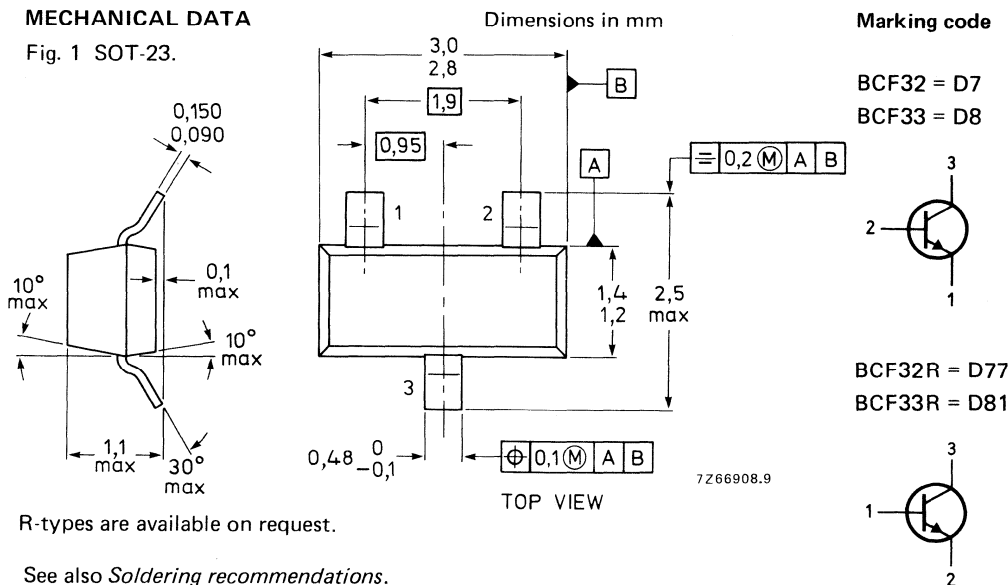

R-types are available on request.

See also *Soldering recommendations*.

RATINGS

Limiting values in accordance with the Absolute Maximum System (IEC 134)

Collector-base voltage (open emitter)	V_{CBO}	max.	32 V
Collector-emitter voltage (open base) $I_C = 2 \text{ mA}$	V_{CEO}	max.	32 V
Emitter-base voltage (open collector)	V_{EBO}	max.	5 V
Collector current (d.c.)	I_C	max.	100 mA
Collector current (peak value)	I_{CM}	max.	200 mA
Total power dissipation up to $T_{amb} = 25 \text{ }^\circ\text{C}^{**}$	P_{tot}	max.	350 mW
Storage temperature	T_{stg}		-65 to + 175 $^\circ\text{C}$
Junction temperature	T_j	max.	175 $^\circ\text{C}$

THERMAL CHARACTERISTICS*

$$T_j = P \times (R_{th j-t} + R_{th t-s} + R_{th s-a}) + T_{amb}$$

Thermal resistance

From junction to tab	$R_{th j-t}$	=	50 K/W
From tab to soldering points	$R_{th t-s}$	=	280 K/W
From soldering points to ambient**	$R_{th s-a}$	=	90 K/W

CHARACTERISTICS

$T_j = 25 \text{ }^\circ\text{C}$ unless otherwise specified

Collector cut-off current

$I_E = 0; V_{CB} = 32 \text{ V}$	I_{CBO}	<	100 nA
$I_E = 0; V_{CB} = 32 \text{ V}; T_j = 100 \text{ }^\circ\text{C}$	I_{CBO}	<	10 μA

Base-emitter voltage

$I_C = 2 \text{ mA}; V_{CE} = 5 \text{ V}$	V_{BE}		550 to 700 mV
--	----------	--	---------------

Saturation voltages

$I_C = 10 \text{ mA}; I_B = 0,5 \text{ mA}$	V_{CEsat}	typ.	120 mV
		<	250 mV

$I_C = 50 \text{ mA}; I_B = 2,5 \text{ mA}$

	V_{BEsat}	typ.	750 mV
	V_{CEsat}	typ.	210 mV
	V_{BEsat}	typ.	850 mV

* See *Thermal characteristics*.

** Mounted on a ceramic substrate of 8 mm x 10 mm x 0,7 mm.

D.C. current gain

$I_C = 10 \mu A; V_{CE} = 5 V$

$I_C = 2 mA; V_{CE} = 5 V$

Collector capacitance at $f = 1 MHz$

$I_E = I_e = 0; V_{CB} = 10 V$

Transition frequency at $f = 35 MHz$

$I_C = 10 mA; V_{CE} = 5 V$

Noise figure at $R_S = 2 k\Omega$

$I_C = 200 \mu A; V_{CE} = 5 V$

$f = 1 kHz; B = 200 Hz$

		BCF32	BCF33
h_{FE}	typ.	150	270
	>	200	420
	<	450	800
C_c	typ.	2,5 pF	←
f_T	typ.	300 MHz	
F	<	4 dB	
	typ.	1,2 dB	

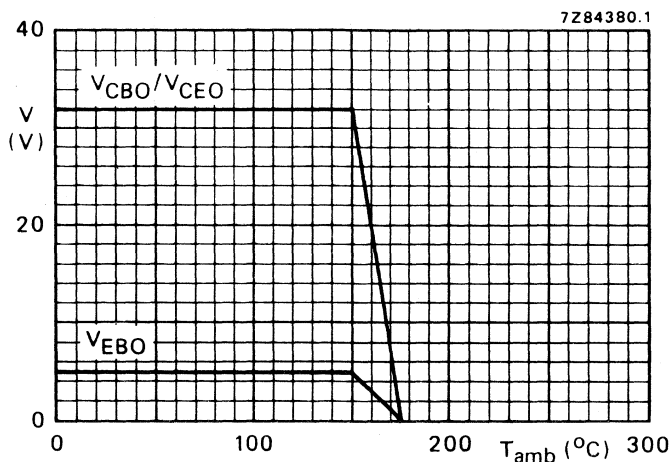

Fig. 2 Voltage derating curves.

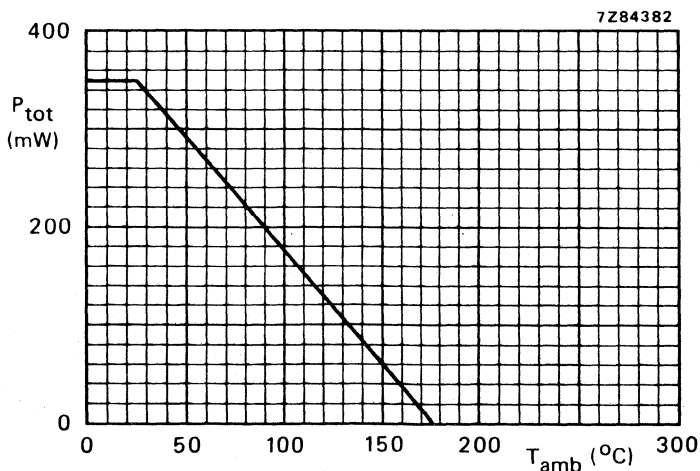

Fig. 3 Power derating curve.

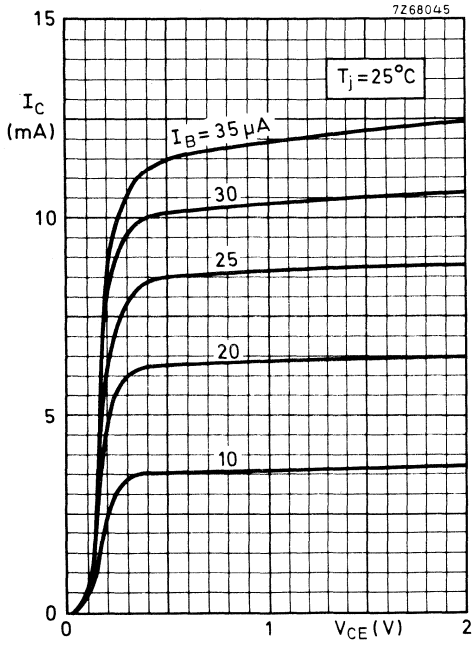

Fig. 4.

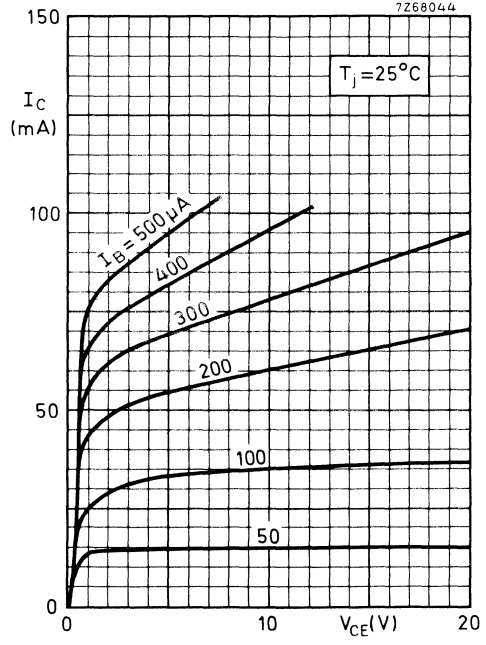

Fig. 5.

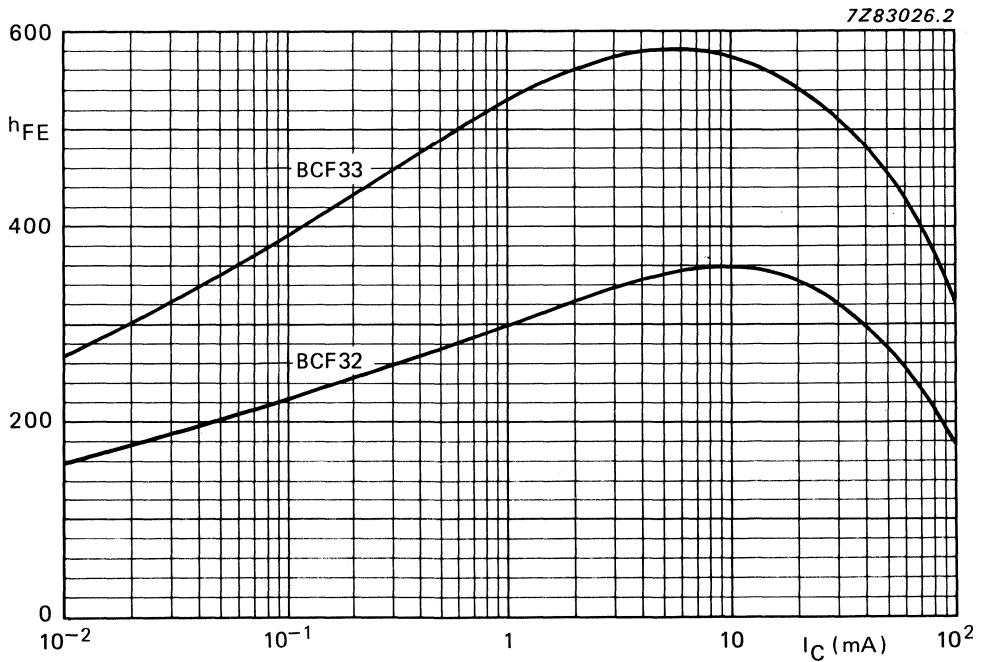

Fig. 6 Typical values d.c. current gain. $V_{CE} = 5 \text{ V}$; $T_j = 25^\circ\text{C}$.

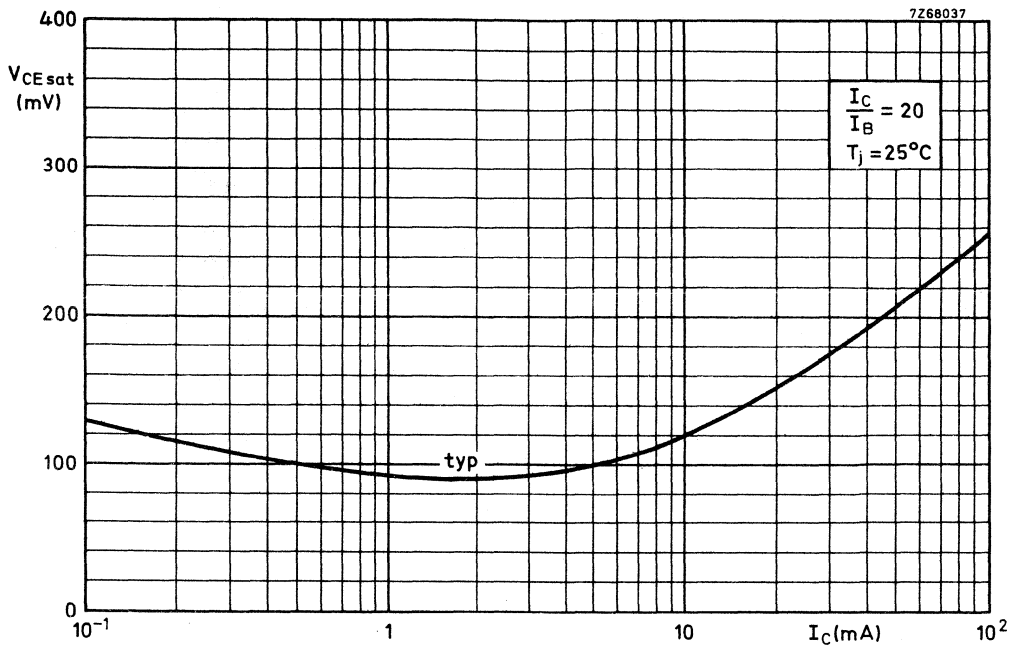

Fig. 7.

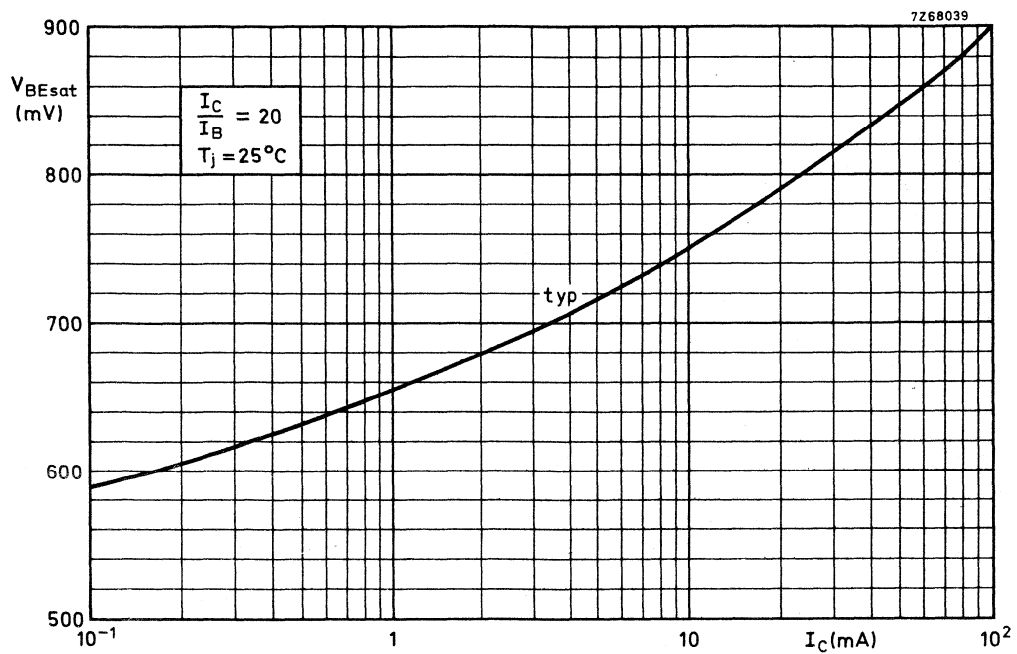

Fig. 8.

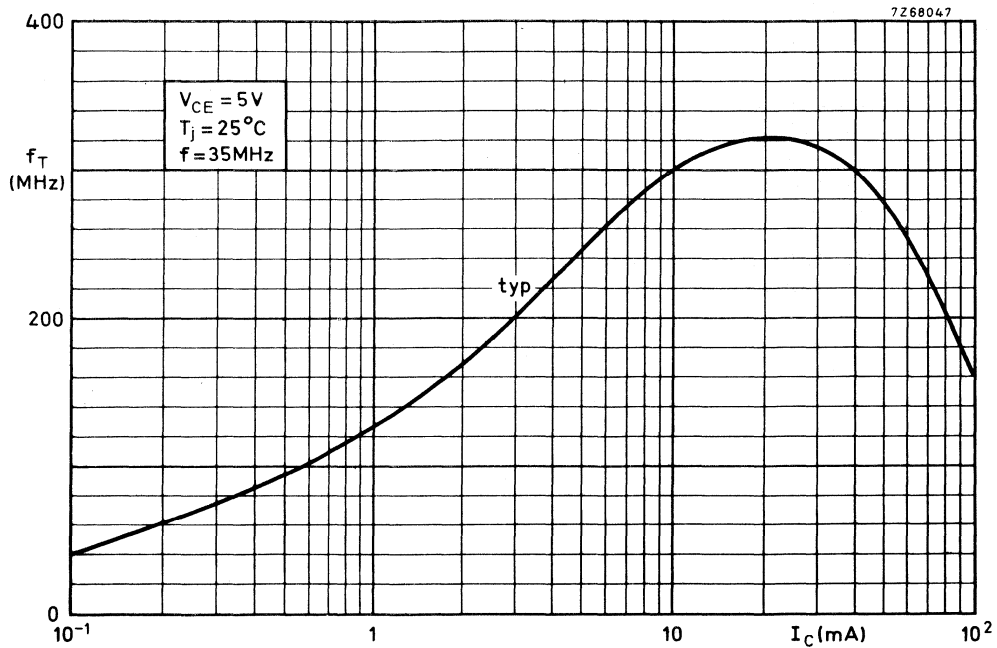

Fig. 9.

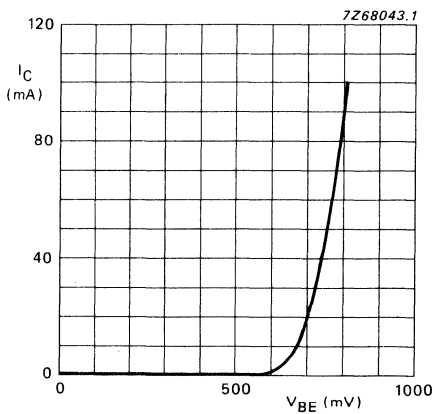

Fig. 10 $V_{CE} = 5V$; $T_j = 25^\circ C$; typical values.

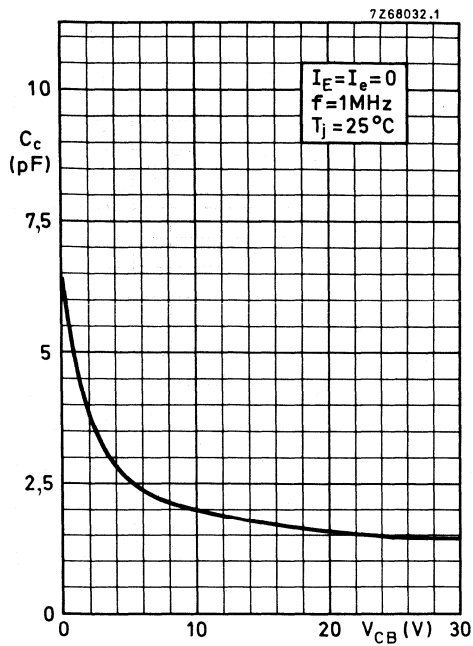

Fig. 11.

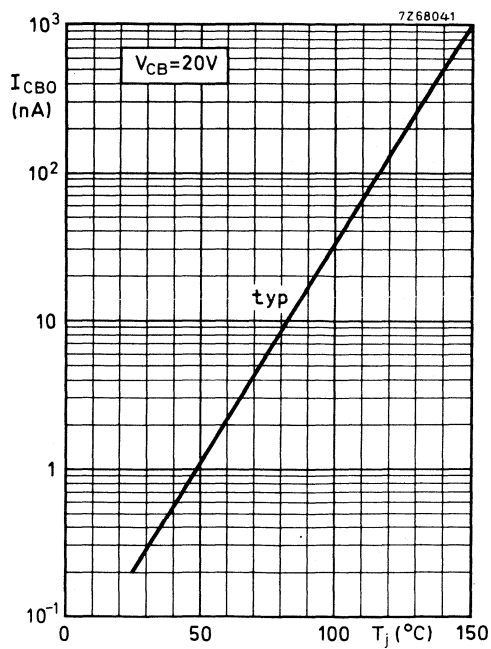

Fig. 12.

SILICON PLANAR EPITAXIAL TRANSISTORS

P-N-P transistors, in a microminiature plastic envelope, intended for low level, low noise applications in thick and thin-film circuits.

QUICK REFERENCE DATA

D.C. current gain at $T_j = 25\text{ }^\circ\text{C}$ $-I_C = 2\text{ mA}; -V_{CE} = 5\text{ V}$	h_{FE}	$>$	215
		$<$	500
Collector-base voltage (open emitter)	$-V_{CBO}$	max.	50 V
Collector-emitter voltage (open base)	$-V_{CEO}$	max.	45 V
Collector current (peak value)	$-I_{CM}$	max.	200 mA
Total power dissipation up to $T_{amb} = 25\text{ }^\circ\text{C}$	P_{tot}	max.	350 mW
Junction temperature	T_j	max.	175 $^\circ\text{C}$
Transition frequency at $f = 35\text{ MHz}$ $-I_C = 10\text{ mA}; -V_{CE} = 5\text{ V}$	f_T	typ.	150 MHz
Noise figure at $R_S = 2\text{ k}\Omega$ $-I_C = 200\text{ }\mu\text{A}; -V_{CE} = 5\text{ V};$ $f = 1\text{ kHz}; B = 200\text{ Hz}$	F	$<$	4 dB

MECHANICAL DATA

Fig. 1 SOT-23.

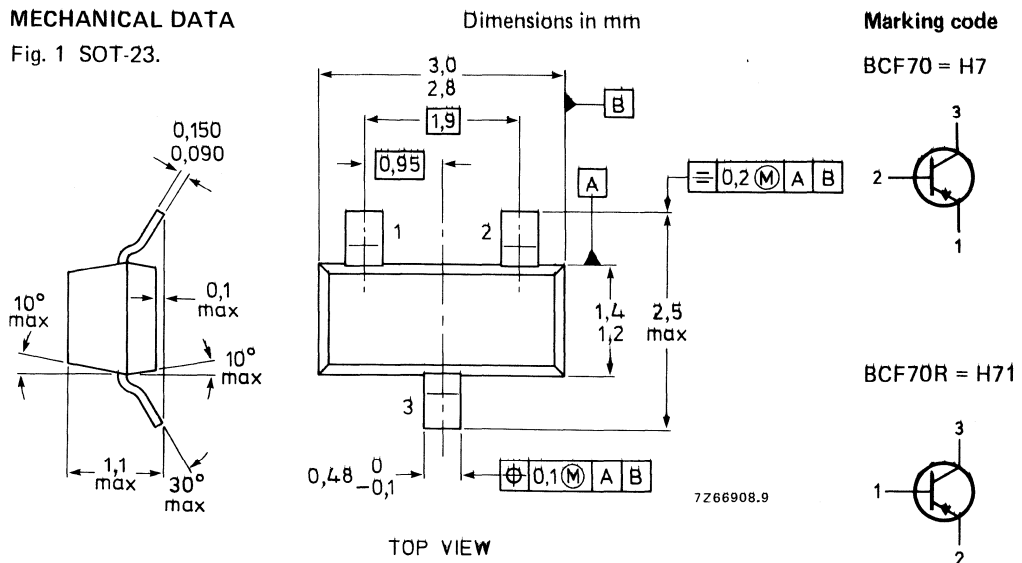

R-types are available on request.

See also *Soldering recommendations*.

RATINGS

Limiting values in accordance with the Absolute Maximum System (IEC 134)

Collector-base voltage (open emitter) see Fig. 2	$-V_{CBO}$	max.	50 V
Collector-emitter voltage ($V_{BE} = 0$) see Fig. 2	$-V_{CES}$	max.	50 V
Collector-emitter voltage (open base) see Fig. 2 $-I_C = 2$ mA	$-V_{CEO}$	max.	45 V
Emitter-base voltage (open collector) see Fig. 2	$-V_{EBO}$	max.	5 V
Collector current (d.c.)	$-I_C$	max.	100 mA
Collector current (peak value)	$-I_{CM}$	max.	200 mA
Total power dissipation up to $T_{amb} = 25$ °C**	P_{tot}	max.	350 mW
Storage temperature	T_{stg}		-65 to + 175 °C
Junction temperature	T_j	max.	175 °C

THERMAL CHARACTERISTICS*

$$T_j = P_x (R_{th j-t} + R_{th t-s} + R_{th s-a}) + T_{amb}$$

Thermal resistance

From junction to tab	$R_{th j-t}$	=	50 K/W
From tab to soldering points	$R_{th t-s}$	=	280 K/W
From soldering points to ambient**	$R_{th s-a}$	=	90 K/W

CHARACTERISTICS $T_j = 25$ °C unless otherwise specified

$$I_E = 0; -V_{CB} = 20 \text{ V}; T_j = 25 \text{ °C}$$

$$T_j = 100 \text{ °C}$$

Base-emitter voltage $-I_C = 2$ mA; $-V_{CE} = 5$ V; $T_j = 25$ °C	$-V_{BE}$		600 to 750 mV
Saturation voltages $-I_C = 10$ mA; $-I_B = 0,5$ mA	$-V_{CEsat}$	typ. <	80 mV 300 mV
$-I_C = 50$ mA; $-I_B = 2,5$ mA	$-V_{BEsat}$	typ.	720 mV
	$-V_{CEsat}$	typ.	150 mV
	$-V_{BEsat}$	typ.	810 mV

* See *Thermal characteristics*.

** Mounted on a ceramic substrate of 8 mm x 10 mm x 0,7 mm.

D.C. current gain

$-I_C = 10 \mu A; -V_{CE} = 5 V$

h_{FE} typ. 150

$-I_C = 2 mA; -V_{CE} = 5 V$

h_{FE} $>$ 215
 $<$ 500

Collector capacitance at $f = 1 MHz$

$I_E = I_e = 0; -V_{CB} = 10 V$

C_c typ. 4,5 pF ←

Transition frequency at $f = 35 MHz$

$-I_C = 10 mA; -V_{CE} = 5 V$

f_T typ. 150 MHz

Noise figure at $R_S = 2 k\Omega$

$-I_C = 200 \mu A; -V_{CE} = 5 V$

F $<$ 4 dB

$f = 1 kHz; B = 200 Hz$

typ. 1 dB

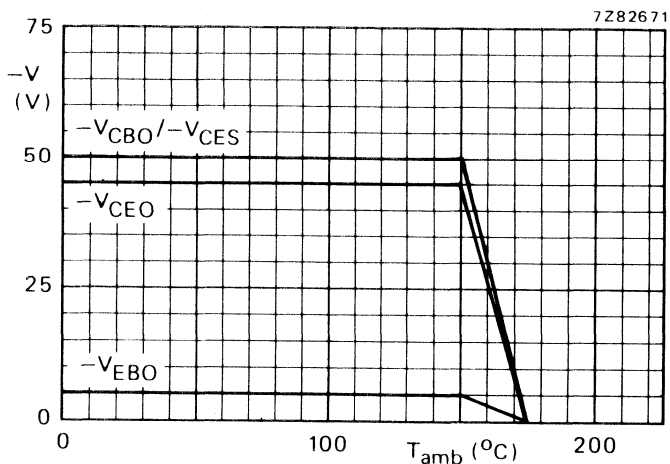

Fig. 2 Voltage derating curves.

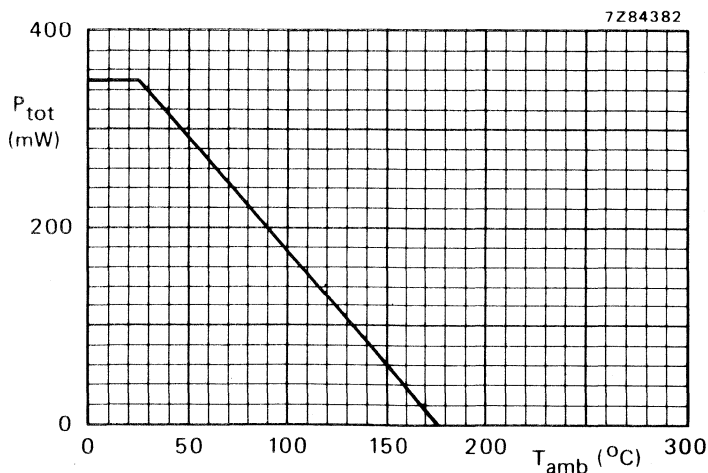

Fig. 3 Power derating curve.

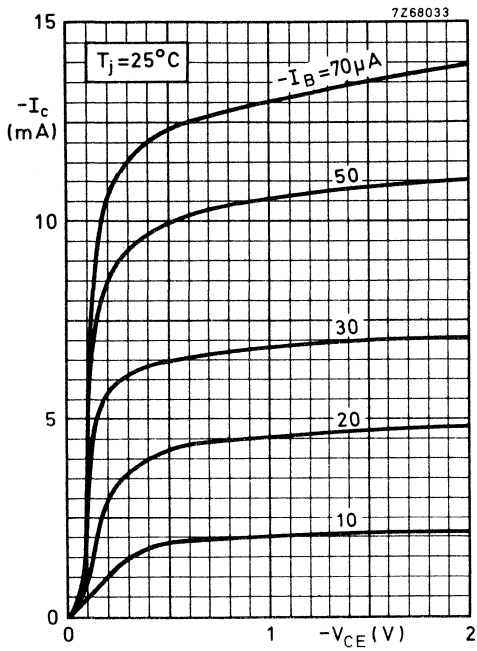

Fig. 4.

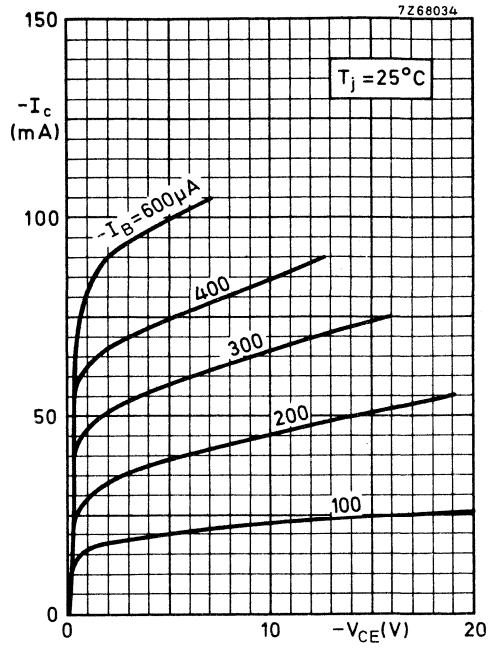

Fig. 5.

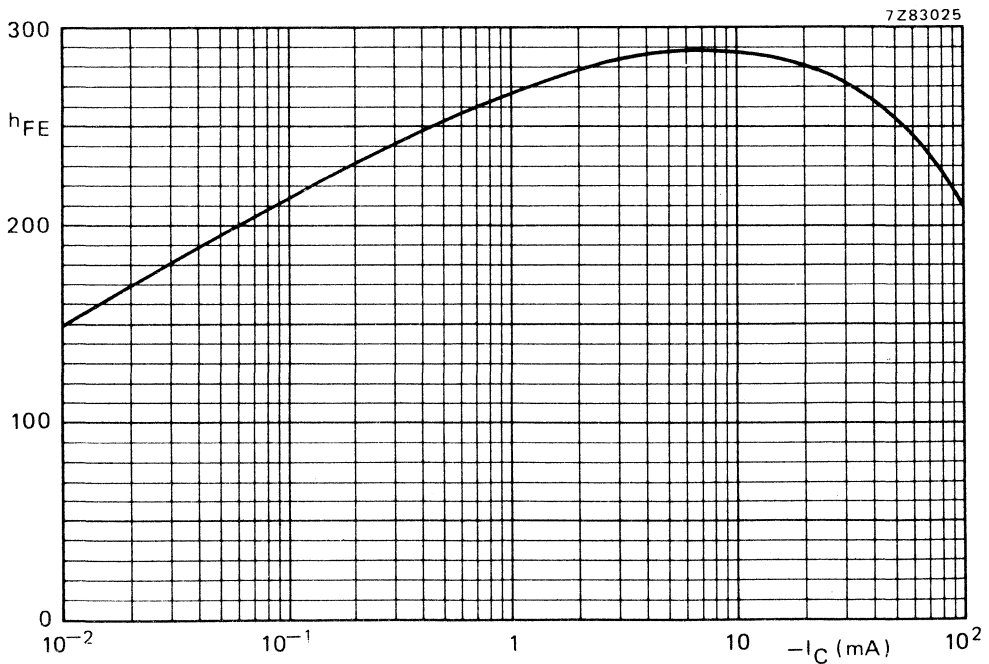

Fig. 6 Typical values of d.c. current gain. $-V_{CE} = 5\ \text{V}$; $T_j = 25^\circ\text{C}$.

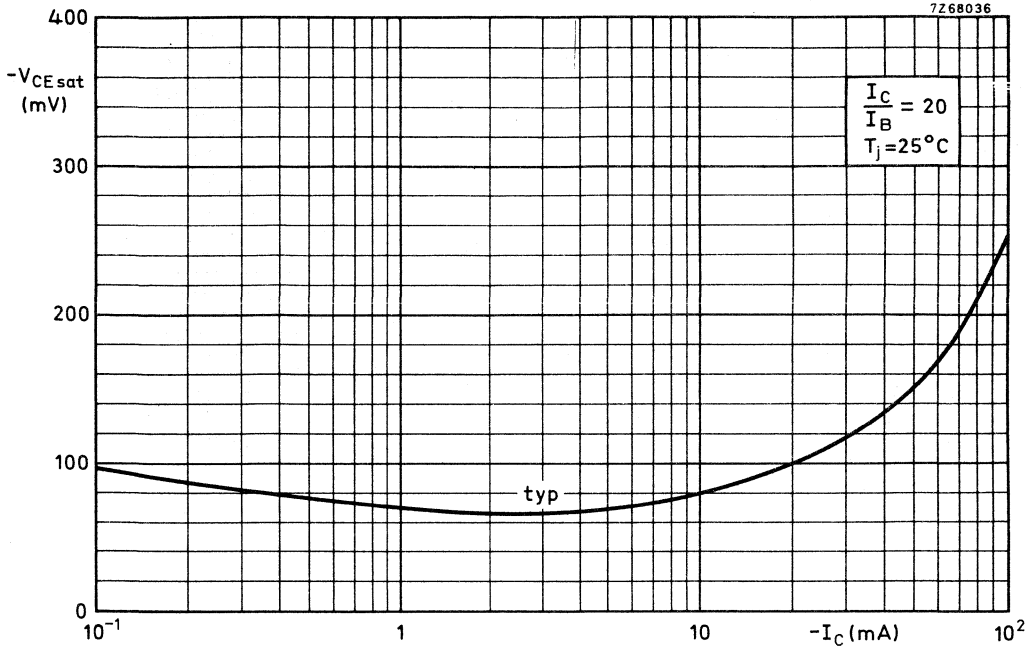

Fig. 7.

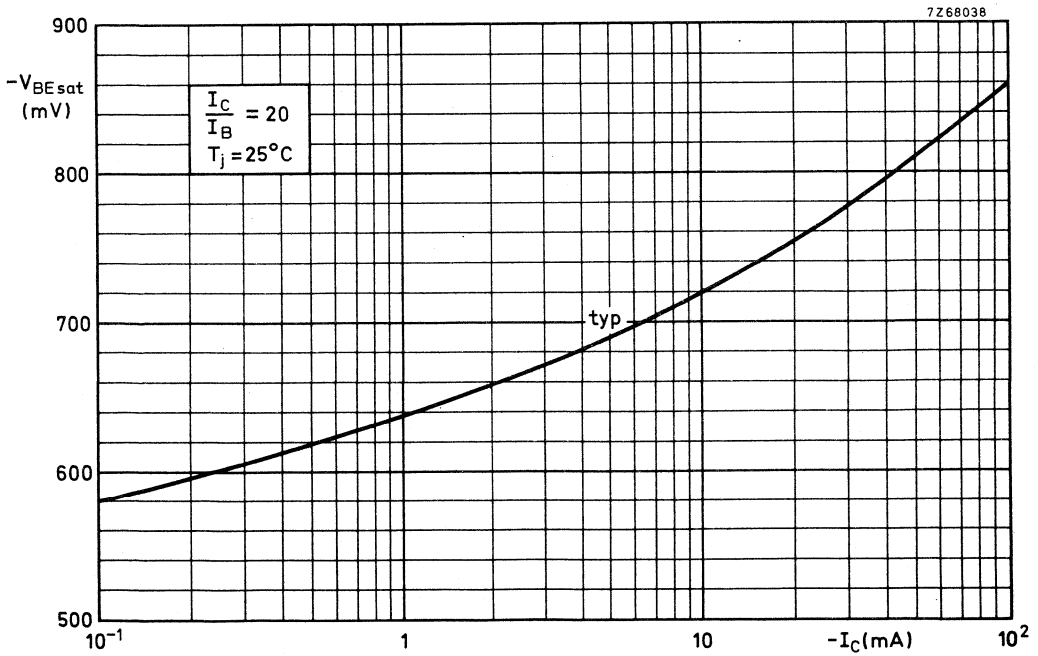

Fig. 8.

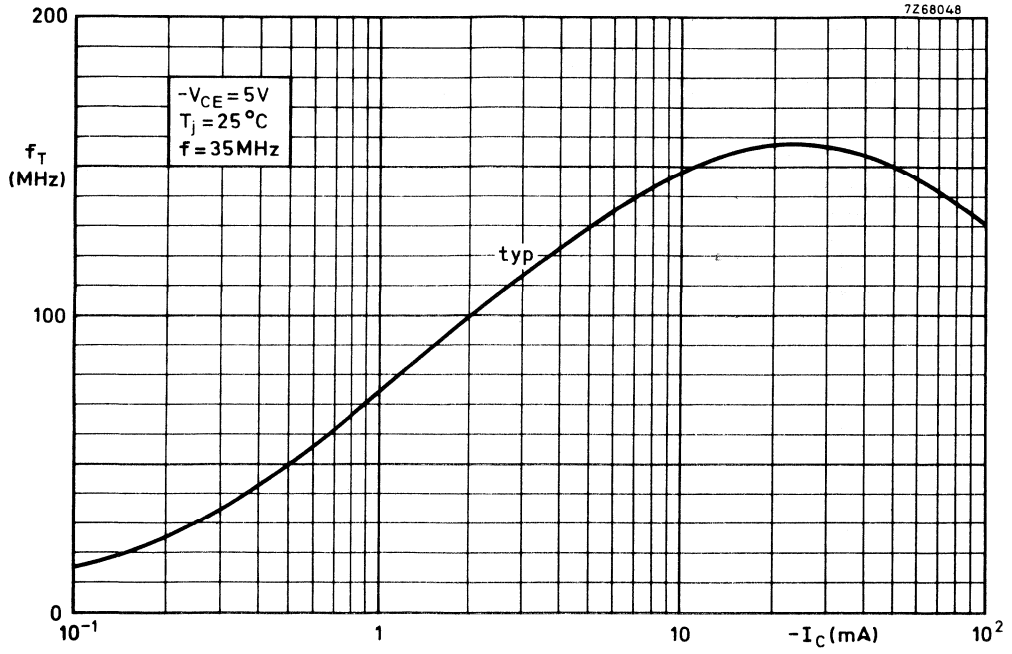

Fig. 9.

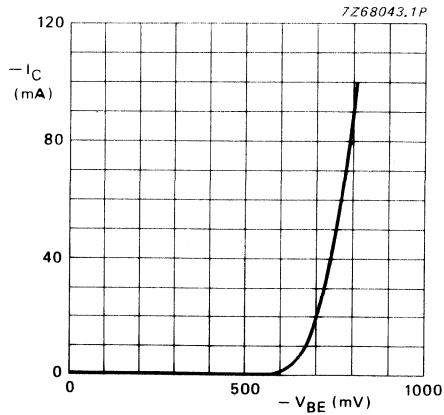

Fig. 10 $-V_{CE} = 5V$; $T_j = 25^\circ C$; typical values.

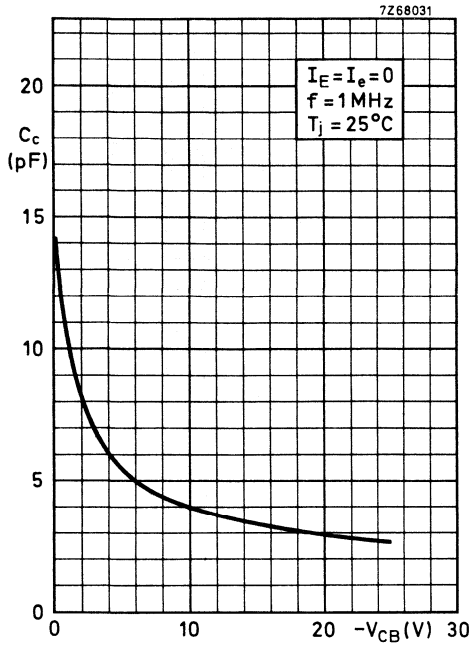

Fig. 11.

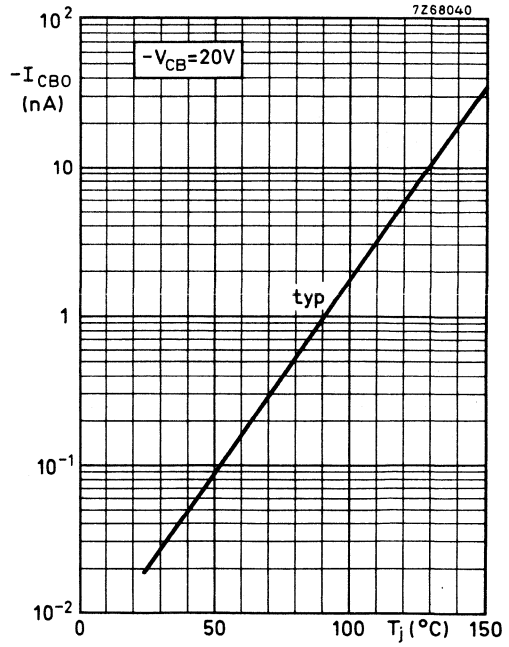

Fig. 12.

SILICON PLANAR EPITAXIAL TRANSISTORS

N-P-N transistors, in a microminiature plastic envelope, intended for low level, low noise general purpose applications in thick and thin-film circuits.

QUICK REFERENCE DATA

Collector-base voltage (open emitter)	V_{CBO}	max.	50 V
Collector-emitter voltage (open base)	V_{CEO}	max.	45 V
Collector current (peak value)	I_{CM}	max.	200 mA
Total power dissipation up to $T_{amb} = 25\text{ }^{\circ}\text{C}$	P_{tot}	max.	350 mW
Junction temperature	T_j	max.	175 $^{\circ}\text{C}$
D.C. current gain at $T_j = 25\text{ }^{\circ}\text{C}$ $I_C = 2\text{ mA}; V_{CE} = 5\text{ V}$	h_{FE}	>	420
		<	800
Transition frequency at $f = 35\text{ MHz}$ $I_C = 10\text{ mA}; V_{CE} = 5\text{ V}$	f_T	typ.	300 MHz
Noise figure at $R_S = 2\text{ k}\Omega$ $I_C = 200\text{ }\mu\text{A}; V_{CE} = 5\text{ V};$ $f = 1\text{ kHz}; B = 200\text{ Hz}$	F	<	4 dB

MECHANICAL DATA

Fig. 1 SOT-23.

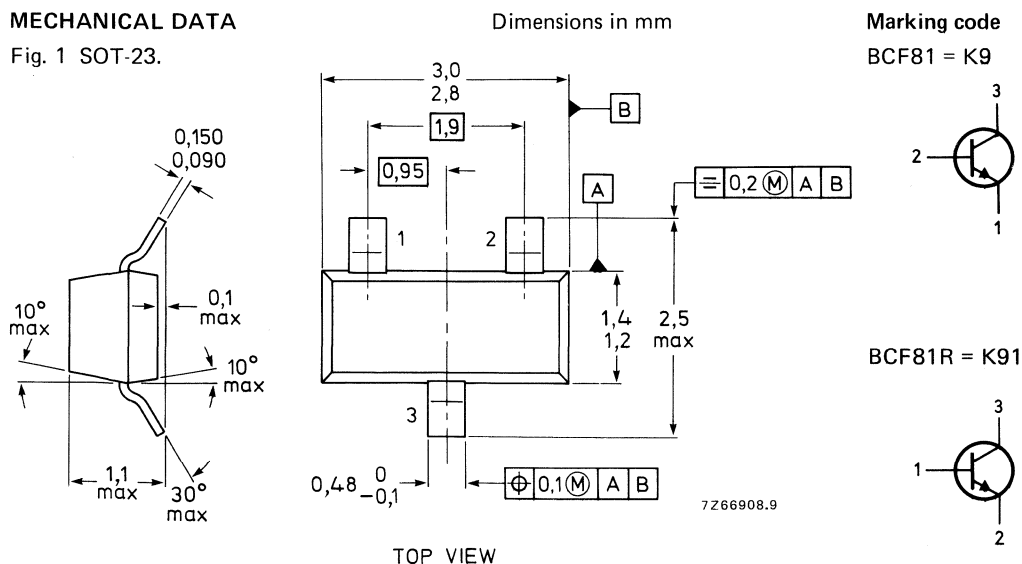

R-types are available on request

See also *Soldering recommendations*.

RATINGS

Limiting values in accordance with the Absolute Maximum System (IEC 134)

Collector-base voltage (open emitter) see Fig. 2	V_{CBO}	max.	50 V
Collector-emitter voltage (open base) see Fig. 2 $I_C = 2 \text{ mA}$	V_{CEO}	max.	45 V
Emitter-base voltage (open collector) see Fig. 2	V_{EBO}	max.	5 V
Collector current (d.c.)	I_C	max.	100 mA
Collector current (peak value)	I_{CM}	max.	200 mA
Total power dissipation up to $T_{amb} = 25 \text{ }^\circ\text{C}^{**}$	P_{tot}	max.	350 mW
Storage temperature	T_{stg}		-65 to + 175 $^\circ\text{C}$
Junction temperature	T_j	max.	175 $^\circ\text{C}$

THERMAL CHARACTERISTICS*

$$T_j = P \times (R_{th j-t} + R_{th t-s} + R_{th s-a}) + T_{amb}$$

Thermal resistance

From junction to tab	$R_{th j-t}$	=	50 K/W
From tab to soldering points	$R_{th t-s}$	=	280 K/W
From soldering points to ambient**	$R_{th s-a}$	=	90 K/W

CHARACTERISTICS $T_j = 25 \text{ }^\circ\text{C}$ unless otherwise specified

Collector cut-off current

$I_E = 0; V_{CB} = 20 \text{ V}$

$I_{CBO} < 100 \text{ nA}$

$I_E = 0; V_{CB} = 20 \text{ V}; T_j = 100 \text{ }^\circ\text{C}$

$I_{CBO} < 10 \text{ } \mu\text{A}$

Base emitter voltage

$I_C = 2 \text{ mA}; V_{CE} = 5 \text{ V}$

$V_{BE} \quad 550 \text{ to } 700 \text{ mV}$

Saturation voltages

$I_C = 10 \text{ mA}; I_B = 0,5 \text{ mA}$

$V_{CEsat} \quad \text{typ. } 120 \text{ mV}$
 $V_{CEsat} < 250 \text{ mV}$

$I_C = 50 \text{ mA}; I_B = 2,5 \text{ mA}$

$V_{BEsat} \quad \text{typ. } 750 \text{ mV}$
 $V_{CEsat} \quad \text{typ. } 210 \text{ mV}$
 $V_{BEsat} \quad \text{typ. } 850 \text{ mV}$

* See *Thermal characteristics*.

** Mounted on a ceramic substrate of 8 mm x 10 mm x 0,7 mm.

D.C. current gain

$I_C = 2 \text{ mA}; V_{CE} = 5 \text{ V}$

$h_{FE} > 420$
 $h_{FE} < 800$

Collector capacitance at $f = 1 \text{ MHz}$

$I_E = I_e = 0; V_{CB} = 10 \text{ V}$

$C_c \text{ typ. } 2,5 \text{ pF} \leftarrow$

Transition frequency at $f = 35 \text{ MHz}$

$I_C = 10 \text{ mA}; V_{CE} = 5 \text{ V}$

$f_T \text{ typ. } 300 \text{ MHz}$

Noise figure at $R_S = 2 \text{ k}\Omega$

$I_C = 200 \mu\text{A}; V_{CE} = 5 \text{ V}$

$f = 1 \text{ kHz}; B = 200 \text{ Hz}$

$F < 4 \text{ dB}$
 $F \text{ typ. } 1,2 \text{ dB}$

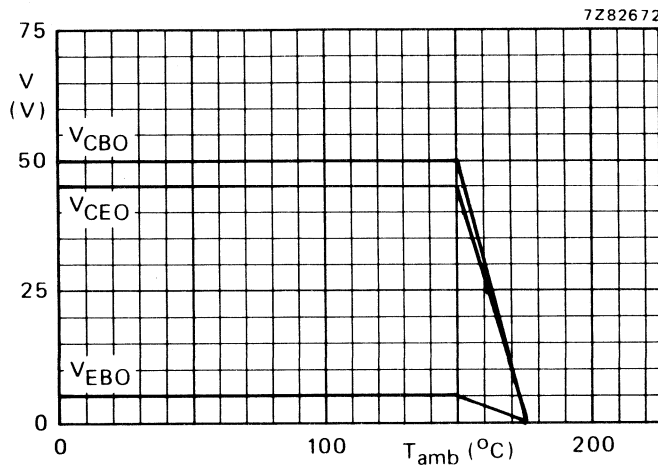

Fig. 2 Voltage derating curves.

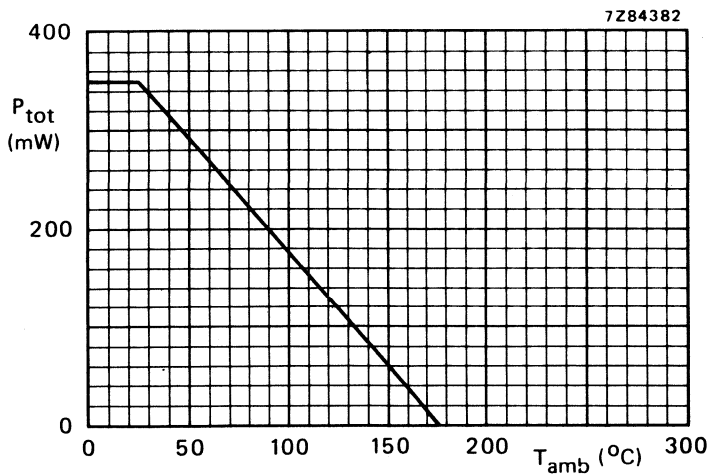

Fig. 3 Power derating curve.

SILICON PLANAR DARLINGTON TRANSISTOR

P-N-P silicon planar Darlington transistor in a plastic SOT-23 envelope.
N-P-N complement is BCV27.

QUICK REFERENCE DATA

Collector-emitter voltage (open base)	$-V_{CEO}$	max.	30 V
Collector-base voltage (open emitter)	$-V_{CBO}$	max.	40 V
Collector current	$-I_C$	max.	300 mA
Junction temperature	T_j	max.	150 °C
Total power dissipation up to $T_{amb} = 25$ °C	P_{tot}	max.	350 mW
Collector-emitter saturation voltage $-I_C = 100$ mA; $-I_B = 0,1$ mA	$-V_{CEsat}$	max.	1 V
D.C. current gain $-I_C = 1$ mA; $-V_{CE} = 5$ V	h_{FE}	>	4 000
$-I_C = 10$ mA; $-V_{CE} = 5$ V	h_{FE}	>	10 000
$-I_C = 100$ mA; $-V_{CE} = 5$ V	h_{FE}	>	20 000
Transition frequency at $f = 100$ MHz $-I_C = 30$ mA; $-V_{CE} = 5$ V	f_T		220 MHz

MECHANICAL DATA

Fig. 1 SOT-23.

Dimensions in mm

Marking: FD

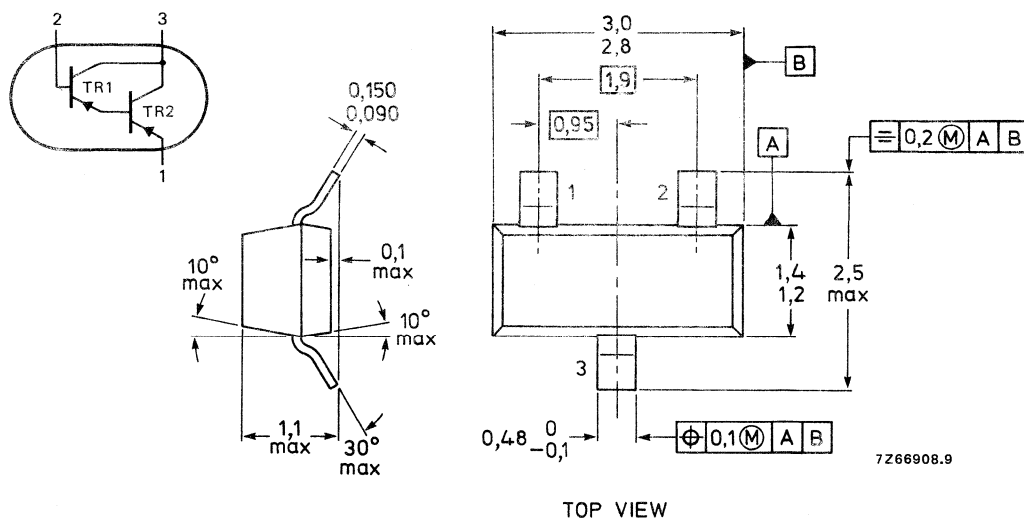

RATINGS

Limiting values in accordance with the Absolute Maximum System (IEC 134)

Collector-emitter voltage (open base)	$-V_{CEO}$	max.	30 V
Collector-base voltage (open emitter)	$-V_{CBO}$	max.	40 V
Emitter-base voltage (open collector)	$-V_{EBO}$	max.	10 V
Collector current	$-I_C$	max.	300 mA
Collector current (peak value)	$-I_{CM}$	max.	800 mA
Base current	$-I_B$	max.	100 mA
Total power dissipation up to $T_{amb} = 25\text{ }^\circ\text{C}^*$	P_{tot}	max.	350 mW
Storage temperature	T_s		-65 to + 150 $^\circ\text{C}$
Junction temperature	T_j	max.	150 $^\circ\text{C}$

THERMAL RESISTANCE

From junction to ambient*	$R_{th\ j-a}$	max.	350 K/W
---------------------------	---------------	------	---------

CHARACTERISTICS $T_{amb} = 25\text{ }^\circ\text{C}$ unless otherwise stated

Collector-base current $-V_{CBO} = 30\text{ V}$	$-I_{CBO}$	max.	100 nA
Emitter-base current $-V_{EB} = 10\text{ V}$	$-I_{EBO}$	max.	100 nA
Collector-emitter breakdown voltage $-I_C = 10\text{ mA}$	$-V_{(BR)CEO}$	min.	30 V
Collector-base breakdown voltage $-I_C = 10\text{ }\mu\text{A}$	$-V_{(BR)CBO}$	min.	40 V
Emitter-base breakdown voltage $-I_E = 100\text{ nA}$	$-V_{(BR)EBO}$	min.	10 V
Collector-emitter saturation voltage $-I_C = 100\text{ mA}; -I_B = 0,1\text{ mA}$	$-V_{CEsat}$	max.	1 V
Base-emitter saturation voltage $-I_C = 100\text{ mA}; -I_B = 0,1\text{ mA}$	$-V_{BEsat}$	max.	1,5 V
D.C. current gain	h_{FE}	>	4 000
$-I_C = 1\text{ mA}; -V_{CE} = 5\text{ V}$	h_{FE}	>	10 000
$-I_C = 10\text{ mA}; -V_{CE} = 5\text{ V}$	h_{FE}	>	20 000
$-I_C = 100\text{ mA}; -V_{CE} = 5\text{ V}$	h_{FE}	>	20 000
Transition frequency at $f = 100\text{ MHz}$ $-I_C = 30\text{ mA}; -V_{CE} = 5\text{ V}$	f_T	typ.	220 MHz
Collector capacitance at $f = 1\text{ MHz}$ $I_E = 0; -V_{CB} = 30\text{ V}$	C_C	typ.	3,5 pF

* Mounted on a ceramic substrate of 15 mm x 15 mm x 0,7 mm.

SILICON PLANAR DARLINGTON TRANSISTOR

N-P-N silicon planar Darlington transistor in a plastic SOT-23 envelope.
P-N-P complement is BCV26.

QUICK REFERENCE DATA

Collector-emitter voltage (open base)	V_{CEO}	max.	30 V
Collector-base voltage (open emitter)	V_{CBO}	max.	40 V
Collector current	I_C	max.	300 mA
Junction temperature	T_j	max.	150 °C
Total power dissipation up to $T_{amb} = 25\text{ °C}$	P_{tot}	max.	350 mW
Collector-emitter saturation voltage $I_C = 100\text{ mA}; I_B = 0,1\text{ mA}$	V_{CEsat}	max.	1 V
D.C. current gain $I_C = 1\text{ mA}; V_{CE} = 5\text{ V}$	h_{FE}	>	4 000
$I_C = 10\text{ mA}; V_{CE} = 5\text{ V}$	h_{FE}	>	10 000
$I_C = 100\text{ mA}; V_{CE} = 5\text{ V}$	h_{FE}	>	20 000
Transition frequency at $f = 100\text{ MHz}$ $I_C = 30\text{ mA}; V_{CE} = 5\text{ V}$	f_T	typ.	220 MHz

MECHANICAL DATA

Fig. 1 SOT-23.

Dimensions in mm

Marking: FF

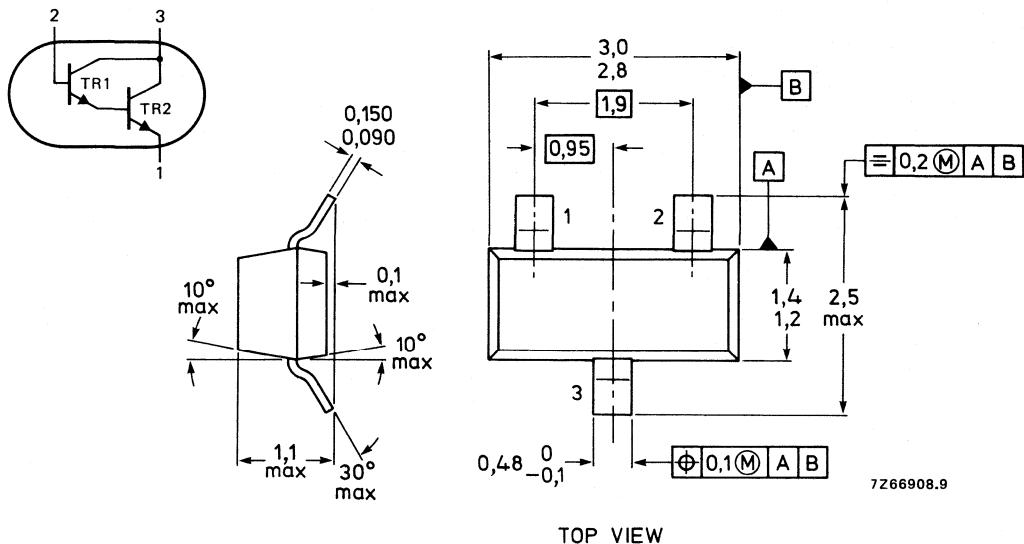

RATINGS

Limiting values in accordance with the Absolute Maximum System (IEC 134)

Collector-emitter voltage (open base)	V_{CEO}	max.	30 V
Collector-base voltage (open emitter)	V_{CBO}	max.	40 V
Emitter-base voltage (open collector)	V_{EBO}	max.	10 V
Collector current	I_C	max.	300 mA
Collector current (peak value)	I_{CM}	max.	800 mA
Base current	I_B	max.	100 mA
Total power dissipation up to $T_{amb} = 25\text{ }^\circ\text{C}^*$	P_{tot}	max.	350 mW
Storage temperature	T_s		-65 to +150 $^\circ\text{C}$
Junction temperature	T_j	max.	150 $^\circ\text{C}$

THERMAL RESISTANCE

From junction to ambient*	$R_{th\ j-a}$	max.	350 K/W
---------------------------	---------------	------	---------

CHARACTERISTICS $T_{amb} = 25\text{ }^\circ\text{C}$ unless otherwise stated

Collector-base current $V_{CBO} = 30\text{ V}$	I_{CBO}	max.	100 nA
Emitter-base current $V_{EB} = 10\text{ V}$	I_{EBO}	max.	100 nA
Collector-emitter breakdown voltage $I_C = 10\text{ mA}$	$V_{(BR)CEO}$	min.	30 V
Collector-base breakdown voltage $I_C = 10\text{ }\mu\text{A}$	$V_{(BR)CBO}$	min.	40 V
Emitter-base breakdown voltage $I_E = 100\text{ nA}$	$V_{(BR)EBO}$	min.	10 V
Collector-emitter saturation voltage $I_C = 100\text{ mA}; I_B = 0,1\text{ mA}$	V_{CEsat}	max.	1 V
Base-emitter saturation voltage $I_C = 100\text{ mA}; I_B = 0,1\text{ mA}$	V_{BEsat}	max.	1,5 V
D.C. current gain $I_C = 1\text{ mA}; V_{CE} = 5\text{ V}$	h_{FE}	>	4 000
$I_C = 10\text{ mA}; V_{CE} = 5\text{ V}$	h_{FE}	>	10 000
$I_C = 100\text{ mA}; V_{CE} = 5\text{ V}$	h_{FE}	>	20 000
Transition frequency at $f = 100\text{ MHz}$ $I_C = 30\text{ mA}; V_{CE} = 5\text{ V}$	f_T	typ.	220 MHz
Collector capacitance at $f = 1\text{ MHz}$ $I_E = 0; V_{CB} = 30\text{ V}$	C_c	typ.	3,5 pF

* Mounted on a ceramic substrate of 15 mm x 15 mm x 0,7 mm.

SILICON PLANAR EPITAXIAL TRANSISTOR

Double n-p-n transistor, in SOT-143 plastic envelope, designed for use in applications where the working point must be independent of temperature.

Owing to application of two similar crystals of one slice this device has a good thermal coupling and V_{BE} matching. Special interconnection of the two transistor crystals allows the device to be used as a current mirror and the separated emitter leads allow connection to different sources.

A similar device in p-n-p configuration is the BCV62.

QUICK REFERENCE DATA

Collector-emitter voltage (open base) regarding transistor T1	V_{CEO}	max.	30 V
Collector-base voltage (open emitter) regarding transistor T1	V_{CBO}	max.	30 V
Collector current d.c.	I_C	max.	100 mA
peak	I_{CM}	max.	200 mA
Total power dissipation up to $T_{amb} = 25\text{ }^\circ\text{C}$	P_{tot}	max.	300 mW
Junction temperature	T_j	max.	150 $^\circ\text{C}$

MECHANICAL DATA

Fig. 1 SOT-143.

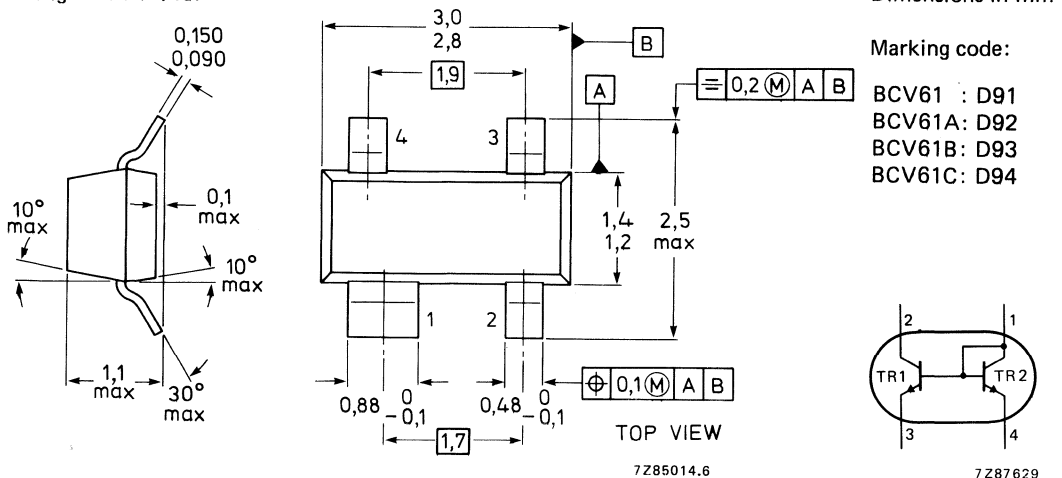

See also *Soldering recommendations*.

RATINGS

Limiting values in accordance with the Absolute Maximum System (IEC 134)

Collector-emitter voltage (open base) regarding transistor T1	V_{CEO}	max.	30 V
Collector-base voltage (open emitter) regarding transistor T1	V_{CBO}	max.	30 V
Base current (transistor T1) peak value	I_{BM1}	max.	200 mA
Emitter-base voltage	V_{EBS}	max.	6 V
Collector current d.c.	I_C	max.	100 mA
peak	I_{CM}	max.	200 mA
Total power dissipation up to $T_{amb} = 25\text{ °C}$ when mounted on a ceramic substrate of 8 mm x 10 mm x 0,7 mm	P_{tot}	max.	300 mW
Junction temperature	T_j	max.	150 °C
Storage temperature	T_{stg}		-65 to +150 °C

THERMAL RESISTANCE

Device mounted on a ceramic substrate of

8 mm x 10 mm x 0,7 mm

from junction to ambient

$$R_{th\ j-a} = 430\text{ K/W}$$

CHARACTERISTICS $T_j = 25\text{ °C}$ unless otherwise specified**Transistor T1**

Collector cut-off current

 $I_E = 0; V_{CB} = 30\text{ V}$ $I_E = 0; V_{CB} = 30\text{ V}; T_j = 150\text{ °C}$

$$I_{CBO} < \begin{matrix} 15\text{ nA} \\ 5\text{ }\mu\text{A} \end{matrix}$$

Base-emitter voltage

 $I_C = 2\text{ mA}; V_{CE} = 5\text{ V}$

$$V_{BE} \begin{matrix} \text{typ.} & 660\text{ mV}^* \\ & 580\text{ to }700\text{ mV}^* \end{matrix}$$

 $I_C = 10\text{ mA}; V_{CE} = 5\text{ V}$

$$V_{BE} < 770\text{ mV}^*$$

Saturation voltages

 $I_C = 10\text{ mA}; I_B = 0,5\text{ mA}$

$$V_{CEsat} \begin{matrix} \text{typ.} & 90\text{ mV} \\ & < 250\text{ mV} \end{matrix}$$

 $I_C = 100\text{ mA}; I_B = 5\text{ mA}$

$$V_{BEsat} \text{typ. } 700\text{ mV}^{**}$$

$$V_{CEsat} \begin{matrix} \text{typ.} & 200\text{ mV} \\ & < 600\text{ mV} \end{matrix}$$

$$V_{BEsat} \text{typ. } 900\text{ mV}^{**}$$

* Decreasing 2 mV/°C with increasing temperature.

** Decreasing 1,7 mV/°C with increasing temperature.

Transition frequency at $f = 35 \text{ MHz}$ $I_C = 10 \text{ mA}; V_{CE} = 5 \text{ V}$	f_T	typ.	300 MHz
Collector capacitance at $f = 1 \text{ MHz}$ $I_E = I_{e} = 0; V_{CB} = 10 \text{ V}$	C_c	typ.	2,5 pF
Noise figure at $R_S = 2 \text{ k}\Omega$ $I_C = 200 \mu\text{A}; V_{CE} = 5 \text{ V}$ $f = 1 \text{ kHz}; B = 200 \text{ Hz}$	F	typ. <	2 dB 10 dB
D.C. current gain $I_C = 100 \mu\text{A}; V_{CE} = 5 \text{ V}$ $I_C = 2 \text{ mA}; V_{CE} = 5 \text{ V}$	h_{FE} h_{FE}	>	100 110 to 800
Input impedance $I_C = 2 \text{ mA}; V_{CE} = 5 \text{ V}; f = 1 \text{ kHz}$	h_{ie}	typ.	5 k Ω
Reverse voltage transfer ratio $I_C = 2 \text{ mA}; V_{CE} = 5 \text{ V}; f = 1 \text{ kHz}$	h_{re}	typ.	2×10^{-4}
Small signal current gain $I_C = 2 \text{ mA}; V_{CE} = 5 \text{ V}; f = 1 \text{ kHz}$	h_{fe}		100 to 900
Output admittance $I_C = 2 \text{ mA}; V_{CE} = 5 \text{ V}; f = 1 \text{ kHz}$	h_{oe}	typ.	30 μS

Transistor T2

Base-emitter forward voltage

$I_E = 250 \text{ mA}$

$I_E = 10 \mu\text{A}$

V_{BES}	<	1,8 V
	>	400 mV

Matching of transistor T1 and transistor T2

at $I_{E2} = 0,5 \text{ mA}$ and $V_{CE1} = 5 \text{ V}$

$T_{amb} = 25 \text{ }^\circ\text{C}$

$T_{amb} = 150 \text{ }^\circ\text{C}$

I_{C1}/I_{C2}	0,7 to 1,3
I_{C1}/I_{C2}	0,7 to 1,3

Thermal coupling of transistor T1 and Transistor T2*

T1 : $V_{CE} = 5 \text{ V}$

Maximum current for thermal stability of I_{C1}

I_{E2}	typ.	5 mA
	min.	110

D.C. current gain

$I_C = 2 \text{ mA}; V_{CE} = 5 \text{ V}$

BCV61A

h_{FE}	typ.	180
	max.	220

BCV61B

h_{FE}	min.	200
	typ.	290
	max.	450

BCV61C

h_{FE}	min.	420
	typ.	520
	max.	800

* Without emitter resistor and device mounted on a ceramic substrate of 8 mm x 10 mm x 0,7 mm.
(See Fig. 2)

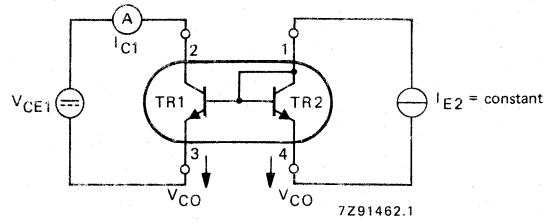

Fig. 2 Test circuit current matching.

Note: Voltage drop at contacts: $V_{CO} < \frac{2}{3} U_T \cong 16 \text{ mV}$.

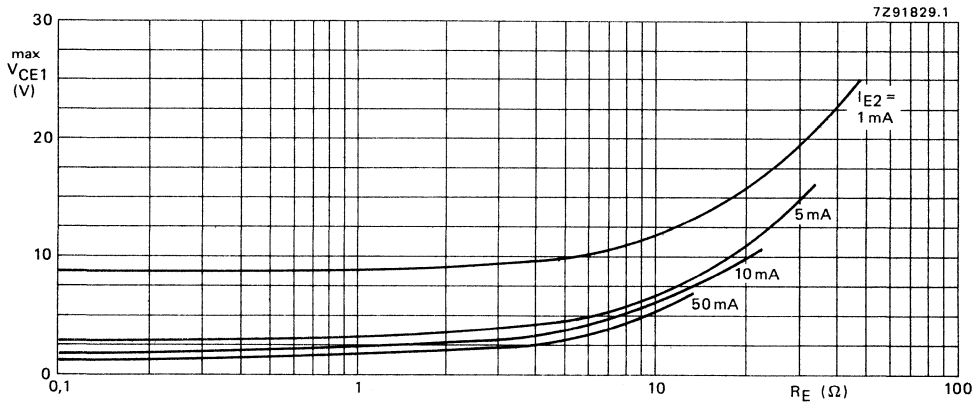

Fig. 3 Characteristic for determination of max. V_{CE1} at specified R_E range with I_{E2} as parameter under condition of $\frac{I_{C1}}{I_{E2}} = 1,3$ (see Fig. 4).

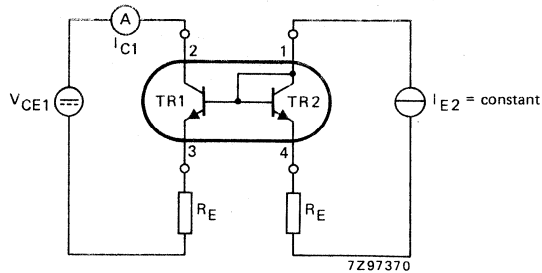

Fig. 4 BCV61 with emitter resistors.

SILICON PLANAR EPITAXIAL TRANSISTOR

Double p-n-p transistor, in SOT-143 plastic envelope, designed for use in applications where the working point must be independent of temperature.

Owing to application of two similar crystals of one slice this device has a good thermal coupling and V_{BE} matching. Special interconnection of the two transistor crystals allows the device to be used as a current mirror and the separated emitter leads allow connection to different sources.

A similar device in n-p-n configuration is the BCV61.

QUICK REFERENCE DATA

Collector-emitter voltage (open base) regarding transistor T1	$-V_{CEO}$	max	30 V
Collector-base voltage (open emitter) regarding transistor T1	$-V_{CBO}$	max.	30 V
Collector current d.c.	$-I_C$	max.	100 mA
peak	$-I_{CM}$	max.	200 mA
Total power dissipation up to $T_{amb} = 25\text{ }^\circ\text{C}$	P_{tot}	max.	300 mW
Junction temperature	T_j	max.	150 $^\circ\text{C}$

MECHANICAL DATA

Fig. 1 SOT-143.

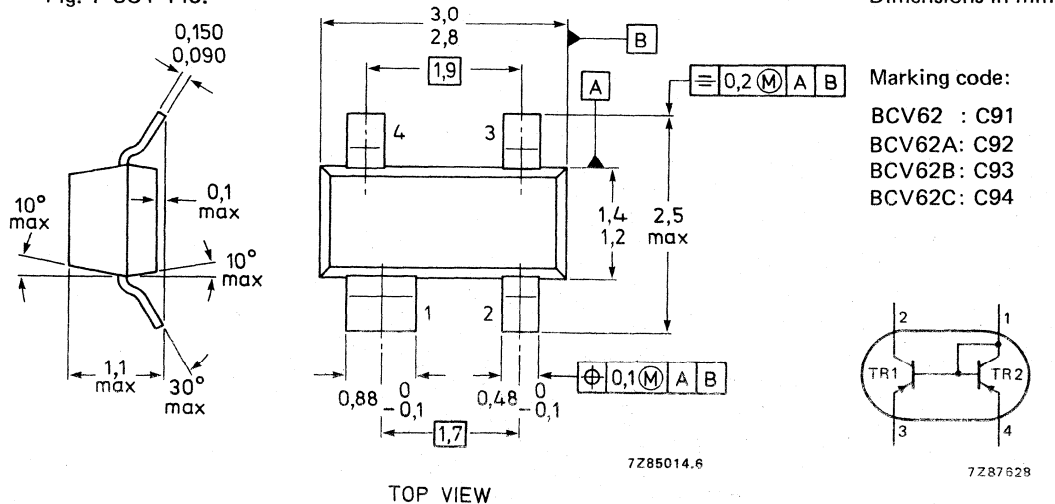

See also *Soldering recommendations*.

RATINGS

Limiting values in accordance with the Absolute Maximum System (IEC 134)

Collector-emitter voltage (open base) regarding transistor T1	$-V_{CEO}$	max.	30 V
Collector-base voltage (open emitter) regarding transistor T1	$-V_{CBO}$	max.	30 V
Base current (transistor T1) peak value	$-I_{BM1}$	max.	200 mA
Emitter-base voltage	$-V_{EBS}$	max.	6 V
Collector current d.c.	$-I_C$	max.	100 mA
peak	$-I_{CM}$	max.	200 mA
Total power dissipation up to $T_{amb} = 25\text{ }^\circ\text{C}$ when mounted on a ceramic substrate of 8 mm x 10 mm x 0,7 mm	P_{tot}	max.	300 mW
Junction temperature	T_j	max.	150 $^\circ\text{C}$
Storage temperature	T_{stg}		-65 to + 150 $^\circ\text{C}$

THERMAL RESISTANCE

Device mounted on a ceramic substrate of
8 mm x 10 mm x 0,7 mm

from junction to ambient

$$R_{th\ j-a} = 430\text{ K/W}$$

CHARACTERISTICS

 $T_j = 25\text{ }^\circ\text{C}$ unless otherwise specified

Transistor T1

Collector cut-off current

$$-I_E = 0; -V_{CB} = 30\text{ V}$$

$$-I_{CBO} < 15\text{ nA}$$

$$-I_E = 0; -V_{CB} = 30\text{ V}; T_j = 150\text{ }^\circ\text{C}$$

$$< 5\text{ }\mu\text{A}$$

Base-emitter voltage

$$-I_C = 2\text{ mA}; -V_{CE} = 5\text{ V}$$

$$-V_{BE} \text{ typ. } 650\text{ mV}^*$$

$$600\text{ to }750\text{ mV}^*$$

$$-I_C = 10\text{ mA}; -V_{CE} = 5\text{ V}$$

$$-V_{BE} < 820\text{ mV}^*$$

Saturation voltages

$$-I_C = 10\text{ mA}; -I_B = 0,5\text{ mA}$$

$$-V_{CEsat} \text{ typ. } 75\text{ mV}$$

$$< 300\text{ mV}$$

$$-V_{BEsat} \text{ typ. } 700\text{ mV}^{**}$$

$$-I_C = 100\text{ mA}; -I_B = 5\text{ mA}$$

$$-V_{CEsat} \text{ typ. } 250\text{ mV}$$

$$< 650\text{ mV}$$

$$-V_{BEsat} \text{ typ. } 850\text{ mV}^{**}$$

* Decreasing 2 mV/ $^\circ\text{C}$ with increasing temperature.** Decreasing 1,7 mV/ $^\circ\text{C}$ with increasing temperature.

Transition frequency at $f = 35$ MHz $-I_C = 10$ mA; $-V_{CE} = 5$ V	f_T	typ.	150 MHz
Collector capacitance at $f = 1$ MHz $I_E = i_e = 0$; $-V_{CB} = 10$ V	C_c	typ.	4,5 pF
Noise figure at $R_S = 2$ k Ω $-I_C = 200$ μ A; $-V_{CE} = 5$ V $f = 1$ kHz; $B = 200$ Hz	F	typ. <	2 dB 10 dB
D.C. current gain $-I_C = 100$ μ A; $-V_{CE} = 5$ V	h_{FE}	>	100
$-I_C = 2$ mA; $-V_{CE} = 5$ V	h_{FE}		100 to 800
Input impedance $-I_C = 2$ mA; $-V_{CE} = 5$ V; $f = 1$ kHz	h_{ie}	typ.	3 k Ω
Reverse voltage transfer ratio $-I_C = 2$ mA; $-V_{CE} = 5$ V; $f = 1$ kHz	h_{re}	typ.	3×10^{-4}
Small signal current gain $-I_C = 2$ mA; $-V_{CE} = 5$ V; $f = 1$ kHz	h_{fe}		100 to 900
Output admittance $-I_C = 2$ mA; $-V_{CE} = 5$ V; $f = 1$ kHz	h_{oe}	typ.	50 μ S
Transistor T2			
Base-emitter forward voltage $-I_E = 250$ mA $-I_E = 10$ μ A	$-V_{BES}$	< >	1,5 V 400 mV
Matching of transistor T1 and transistor T2 at $I_{E2} = 0,5$ mA and $V_{CE1} = 5$ V			
$T_{amb} = 25$ $^{\circ}$ C	I_{C1}/I_{C2}		0,7 to 1,3
$T_{amb} = 150$ $^{\circ}$ C	I_{C1}/I_{C2}		0,7 to 1,3
Thermal coupling of transistor T1 and transistor T2* T1 : $-V_{CE} = 5$ V Maximum current for thermal stability of $-I_{C1}$	I_{E2}	typ.	5 mA
D.C. current gain		min.	125
	BCV62A	h_{FE}	typ. 180 max. 250
		min.	220
	BCV62B	h_{FE}	typ. 290 max. 475
		min.	420
	BCV62C	h_{FE}	typ. 520 max. 800

* Without emitter resistor and device mounted on a ceramic substrate of 8 mm x 10 mm x 0,7 mm.
(see Fig. 2)

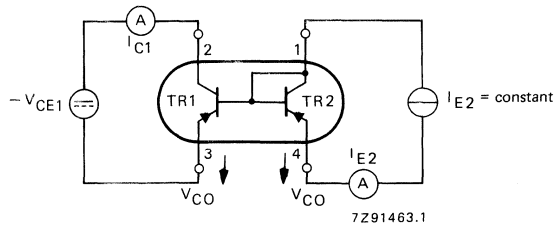

Fig. 2 Test circuit current matching.

Note: Voltage drop at contacts: $V_{CO} < \frac{2}{3} U_T \cong 16 \text{ mV}$.

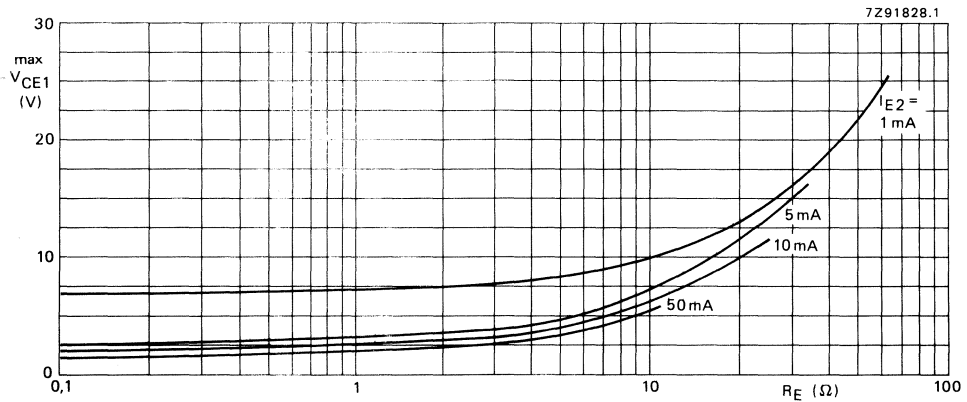

Fig. 3 Characteristic for determination of max. V_{CE1} at specified R_E range with I_{E2} as parameter under condition of $\frac{I_{C1}}{I_{E2}} = 1,3$ (see Fig. 4).

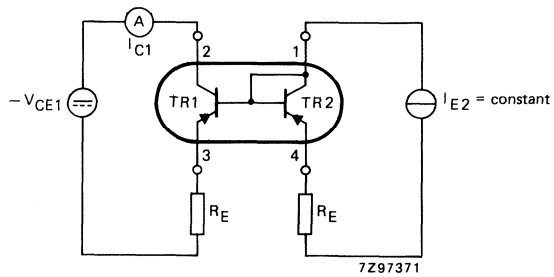

Fig. 4 BCV62 with emitter resistors.

DEVELOPMENT DATA

This data sheet contains advance information and specifications are subject to change without notice.

BCV63

SILICON PLANAR TRANSISTOR

Double N-P-N transistor in a plastic SOT-143 envelope. Intended for Schmitt-trigger applications.
P-N-P complement is the BCV64.

QUICK REFERENCE DATA

	transistor	T1	T2
Collector-emitter voltage (open base)	V_{CEO} max.	30	6 V
Collector-base voltage (open emitter)	V_{CBO} max.	30	6 V
Collector current	I_C max.	100	mA
Junction temperature	T_j max.	150	°C
Total power dissipation up to $T_{amb} = 25\text{ °C}$	P_{tot} max.	300	mW
Collector-emitter saturation voltage $I_C = 10\text{ mA}; I_B = 0,5\text{ mA}$	V_{CEsat} max.	300	mV
Small signal current gain	h_{fe}	100 to 900	
Transition frequency at $f = 35\text{ MHz}$ $I_C = 10\text{ mA}; V_{CE} = 5\text{ V}$	f_T typ.	200	— MHz

MECHANICAL DATA

Dimensions in mm

Fig. 1 SOT-143.

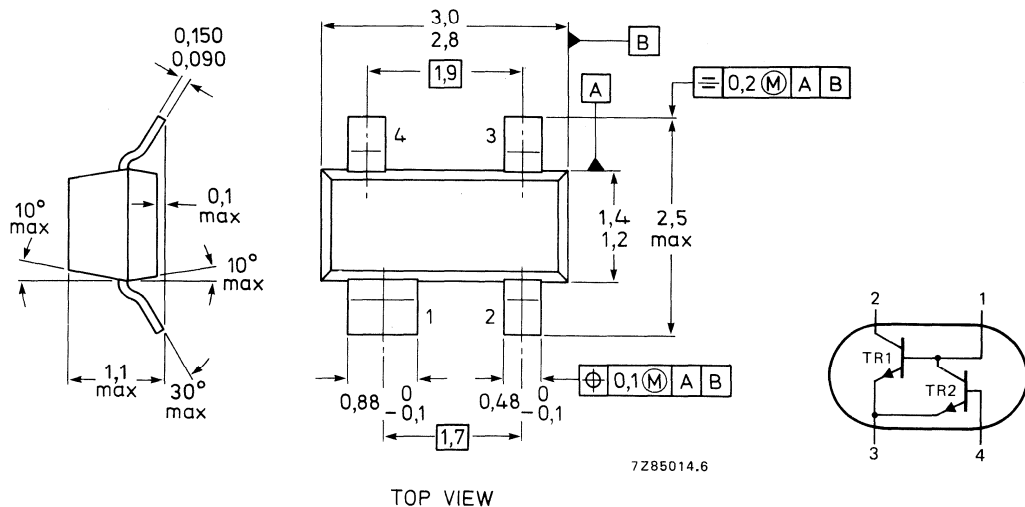

RATINGS

Limiting values in accordance with the Absolute Maximum System (IEC 134)

	transistor	T1	T2
Collector-emitter voltage (open base)	V_{CEO} max.	30	6 V
Collector-base voltage (open emitter)	V_{CBO} max.	30	6 V
Emitter-base voltage (open collector)	V_{EBO} max.	6	V
Collector current (d.c.)	I_C max.	100	mA
Collector current (peak value)	I_{CM} max.	200	mA
Total power dissipation up to $T_{amb} = 25\text{ }^\circ\text{C}^*$	P_{tot} max.	300	mW
Storage temperature	T_s	-65 to +150	$^\circ\text{C}$
Junction temperature	T_j max.	150	$^\circ\text{C}$

THERMAL RESISTANCE

From junction to ambient*

$R_{th\ j-a}$ max.	430	K/W
--------------------	-----	-----

CHARACTERISTICS

$T_{amb} = 25\text{ }^\circ\text{C}$ unless otherwise stated

	transistor	T1	T2
Collector cut-off current $I_E = 0; V_{CBO} = 30\text{ V}$	I_{CBO} max.	15	15 nA
$I_E = 0; V_{CBO} = 30\text{ V}$ $T_j = 150\text{ }^\circ\text{C}$	I_{CBO} max.	5	5 μA
Saturation voltage** $I_C = 10\text{ mA}; I_B = 0,5\text{ mA}$	V_{CEsat} typ.	75	75 mV
	V_{CEsat} max.	300	300 mV
	V_{BEsat} typ.	700	700 mV
$I_C = 100\text{ mA}; I_B = 5\text{ mA}$	V_{CEsat} typ.	250	250 mV
	V_{CEsat} max.	650	- mV
	V_{BEsat} typ.	850	- mV
Base-emitter voltage \blacktriangle $I_C = 2\text{ mA}; V_{CE} = 5\text{ V}$	V_{BE} min.	600	- mV
	V_{BE} typ.	650	- mV
	V_{BE} max.	750	- mV
$I_C = 10\text{ mA}; V_{CE} = 5\text{ V}$	V_{BE} max.	820	- mV
$I_C = 2\text{ mA}; V_{CE} = 700\text{ mV}$	V_{BE} typ.		700 mV
Collector capacitance at $f = 1\text{ MHz}$ $I_E = i_e = 0; V_{CE} = 10\text{ V}$	C_c typ.	4	- pF
Transition frequency at $f = 35\text{ MHz}$ $I_C = 10\text{ mA}; V_{CE} = 5\text{ V}$	f_T typ.	200	- MHz

* Mounted on a ceramic substrate of 8 mm x 10 mm x 0,7 mm.

** V_{BEsat} decreases by approx 1,7 mV/K with increasing temperature.

\blacktriangle $-V_{BE}$ decreases by about 2 mV/K with increasing temperature.

Small signal current gain at $f = 1 \text{ kHz}$

$I_C = 2 \text{ mA}$; T1 : $V_{CE} = 5 \text{ V}$

T2 : $V_{CE} = 700 \text{ mV}$

h_{fe}

100 to 900

Transistor 1

D.C. current gain

$I_C = 2 \text{ mA}$; $V_{CE} = 5 \text{ V}$

	BCV	63	A	B	C
h_{FE} min.		110	110	200	420
h_{FE} typ.			180	290	520
h_{FE} max.		800	220	450	800

Transistor 2

D.C. current gain

$I_C = 2 \text{ mA}$; $V_{CE} = 700 \text{ mV}$

Group selection will be done on T1. Due to matched crystals h_{FE} values for T2 are the same as T1.

DEVELOPMENT DATA

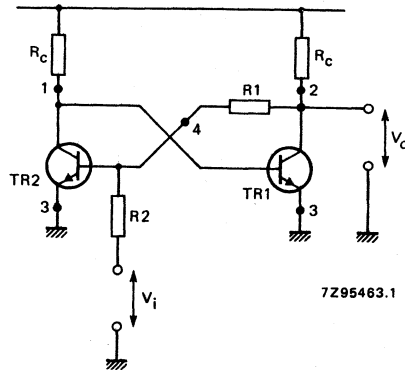

Fig. 2 Schmitt-trigger application.

DEVELOPMENT DATA

This data sheet contains advance information and specifications are subject to change without notice.

BCV64

SILICON PLANAR TRANSISTOR

Double P-N-P transistor in a plastic SOT-143 envelope. Intended for Schmitt-trigger applications.
N-P-N complement is the BCV63.

QUICK REFERENCE DATA

	transistor	T1	T2
Collector-emitter voltage (open base)	$-V_{CE0}$ max.	30	6 V
Collector-base voltage (open emitter)	$-V_{CB0}$ max.	30	6 V
Collector current	$-I_C$ max.	100	mA
Junction temperature	T_j max.	150	°C
Total power dissipation up to $T_{amb} = 25\text{ °C}$	P_{tot} max.	300	mW
Collector-emitter saturation voltage $-I_C = 10\text{ mA}; -I_B = 0,5\text{ mA}$	$-V_{CEsat}$ max.	300	mV
Small signal current gain	h_{fe}	100 to 900	
Transition frequency at $f = 35\text{ MHz}$ $-I_C = 10\text{ mA}; -V_{CE} = 5\text{ V}$	f_T typ.	200	— MHz

MECHANICAL DATA

Dimensions in mm

Fig. 1 SOT-143.

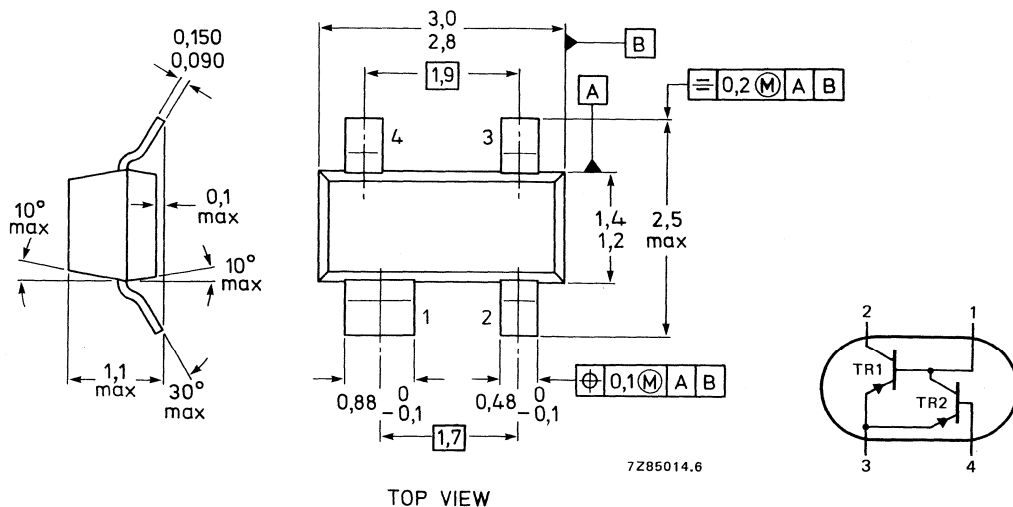

RATINGS

Limiting values in accordance with the Absolute Maximum System (IEC 134)

	transistor	T1	T2
Collector-emitter voltage (open base)	$-V_{CEO}$ max.	30	6 V
Collector-base voltage (open emitter)	$-V_{CBO}$ max.	30	6 V
Emitter-base voltage (open collector)	$-V_{EBO}$ max.	6	6 V
Collector current (d.c.)	$-I_C$ max.	6	mA
Collector current (peak value)	$-I_{CM}$ max.	200	mA
Total power dissipation up to $T_{amb} = 25\text{ }^\circ\text{C}^*$	P_{tot} max.	300	mW
Storage temperature	T_s	-65 to +150	$^\circ\text{C}$
Junction temperature	T_j max.	150	$^\circ\text{C}$

THERMAL RESISTANCE

From junction to ambient*	$R_{th\ j-a}$ max.	430	K/W
---------------------------	--------------------	-----	-----

CHARACTERISTICS $T_{amb} = 25\text{ }^\circ\text{C}$ unless otherwise stated

	transistor	T1	T2
Collector cut-off current $-I_E = 0; -V_{CBO} = 30\text{ V}$	$-I_{CBO}$ max.	15	15 nA
$-I_E = 0; -V_{CBO} = 30\text{ V}$ $T_j = 150\text{ }^\circ\text{C}$	$-I_{CBO}$ max.	5	5 μA
Saturation voltage** $-I_C = 10\text{ mA}; -I_B = 0,5\text{ mA}$	$-V_{CEsat}$ typ.	75	75 mV
	$-V_{CEsat}$ max.	300	300 mV
	$-V_{BEsat}$ typ.	700	700 mV
$-I_C = 100\text{ mA}; -I_B = 5\text{ mA}$	$-V_{CEsat}$ typ.	250	250 mV
	$-V_{CEsat}$ max.	650	- mV
	$-V_{BEsat}$ typ.	850	- mV
Base-emitter voltage \blacktriangle $-I_C = 2\text{ mA}; -V_{CE} = 5\text{ V}$	$-V_{BE}$ typ.	650 600/750	- mV - mV
$-I_C = 10\text{ mA}; -V_{CE} = 5\text{ V}$	$-V_{BE}$ max.	820	- mV
$-I_C = 2\text{ mA}; -V_{CE} = 700\text{ mV}$	$-V_{BE}$ typ.		700 mV
Collector capacitance at $f = 1\text{ MHz}$ $-I_E = i_e = 0; -V_{CE} = 10\text{ V}$	C_c typ.	4	- pF
Transition frequency at $f = 35\text{ MHz}$ $-I_C = 10\text{ mA}; -V_{CE} = 5\text{ V}$	f_T typ.	200	- MHz

* Mounted on a ceramic substrate of 8 mm x 10 mm x 0,7 mm.

** V_{BEsat} decreases by approx 1,7 mV/K with increasing temperature. \blacktriangle $-V_{BE}$ decreases by about 2 mV/K with increasing temperature.

Small signal current gain at $f = 1 \text{ kHz}$

$-I_C = 2 \text{ mA}$; T1 : $-V_{CE} = 5 \text{ V}$

T2 : $-V_{CE} = 700 \text{ mV}$

h_{fe}

100 to 900

Transistor 1

D.C. current gain

$-I_C = 2 \text{ mA}$; $-V_{CE} = 5 \text{ V}$

h_{FE}

BCV	64	A	B	C
min.	110	125	220	420
typ.		180	290	520
max.	800	250	475	800

Transistor 2

D.C. current gain

$-I_C = 2 \text{ mA}$; $-V_{CE} = 700 \text{ mV}$

Group selection will be done on T1. Due to matched crystals h_{FE} values for T2 are the same as T1.

DEVELOPMENT DATA

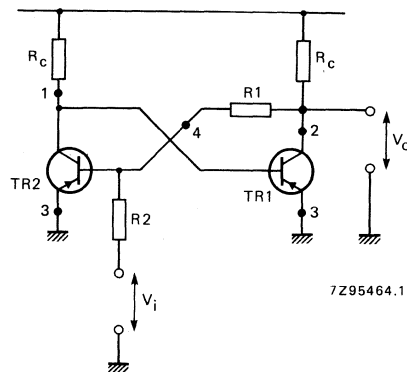

Fig. 2 Schmitt-trigger application.

DEVELOPMENT DATA

This data sheet contains advance information and specifications are subject to change without notice.

BCV65

SILICON PLANAR TRANSISTORS

A pair of two matched P-N-P and N-P-N crystals, based on the BC857 and BC847, in a microminiature SOT-143 envelope.

Complementary crystals give advantages in P.C.B. layout using S.M.D. technology.

QUICK REFERENCE DATA

Collector-emitter voltage (open base)	V_{CE0}	max.	30 V
Collector-base voltage (open emitter)	V_{CBO}	max.	30 V
Collector current	I_C	max.	100 mA
Collector current (peak value)	I_{CM}	max.	200 mA
Total power dissipation up to $T_{amb} = 25^\circ C$	P_{tot}	max.	300 mW
Junction temperature	T_j	max.	150 °C

MECHANICAL DATA

Dimensions in mm

Fig. 1 SOT-143.

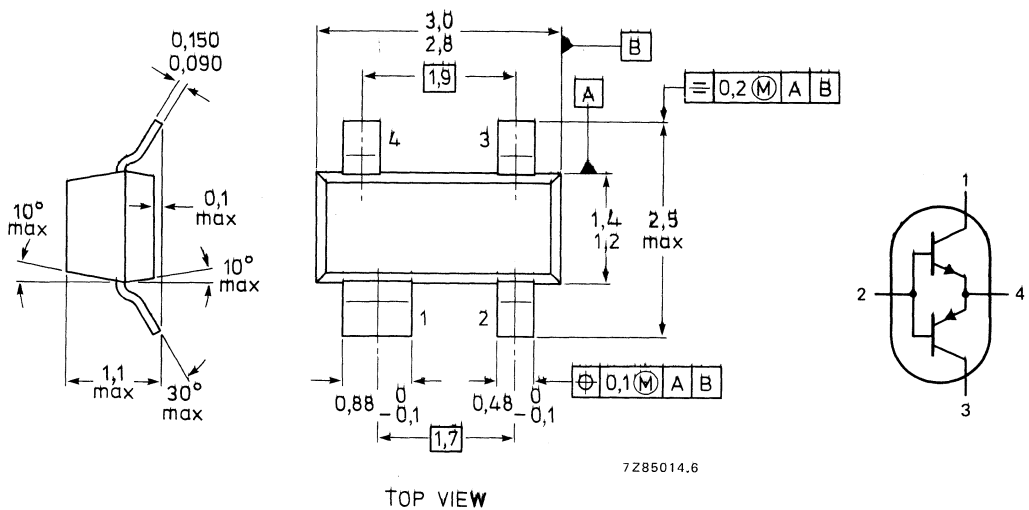

RATINGS

Limiting values in accordance with the Absolute Maximum System (IEC 134)

Per transistor:

Collector-emitter voltage (open base)	V_{CEO}	max.	30 V
Collector-base voltage (open emitter)	V_{CBO}	max.	30 V
Collector current	I_C	max.	100 mA
Collector current (peak value)	I_{CM}	max.	200 mA
Total power dissipation (per device) up to $T_{amb} = 25\text{ }^\circ\text{C}$	P_{tot}	max.	300 mW
Storage temperature	T_s		-65 to $+150\text{ }^\circ\text{C}$
Junction temperature	T_j	max.	$150\text{ }^\circ\text{C}$

THERMAL RESISTANCE

From junction to ambient*	R_{thj-a}	max.	430 K/W
---------------------------	-------------	------	---------

CHARACTERISTICS

Per transistor:

 $T_j = 25\text{ }^\circ\text{C}$ unless otherwise stated

Collector cut-off current $I_E = 0; V_{CB} = 30\text{ V}$ $I_E = 0; V_{CB} = 30\text{ V}$ $T_j = 150\text{ }^\circ\text{C}$	I_{CBO}	max.	15 nA
	I_{CBO}	max.	5 μA
Base-emitter voltage** $I_C = 2\text{ mA}; V_{CE} = 5\text{ V}$	V_{BE}	typ.	650 mV 580 to 750 mV
$I_C = 10\text{ mA}; V_{CE} = 5\text{ V}$	V_{BE}	max.	820 mV
Saturation voltage [▲] $I_C = 10\text{ mA}; I_B = 0,5\text{ mA}$	V_{CEsat}	typ.	90 mV
	V_{BEsat}	max.	300 mV
	V_{BEsat}	typ.	700 mV
$I_C = 100\text{ mA}; I_B = 5\text{ mA}$	V_{CEsat}	typ.	250 mV
	V_{CEsat}	max.	650 mV
	V_{BEsat}	typ.	900 mV
Collector capacitance at $f = 1\text{ MHz}$ $I_E = i_e = 0; V_{CE} = 10\text{ V}$	C_c	typ.	3 pF

* Mounted on a ceramic substrate of 8 mm x 10 mm x 0,7 mm.

** V_{BEsat} decreases by approx. 1,7 mV/K with increasing temperature.▲ $-V_{BE}$ decreases by about 2 mV/K with increasing temperature.

Transition frequency at $f = 35$ MHz

$I_C = 10 \text{ mA}; V_{CE} = 5 \text{ V}$

 f_T min. 100 MHzNoise figure at $f = 35$ MHz

$I_C = 200 \mu\text{A}; V_{CE} = 5 \text{ V};$

$f = 1 \text{ kHz}; B = 200 \text{ Hz}$

F typ. 2 dB
max. 10 dBSmall signal current gain at $f = 1$ kHz

$I_C = 2 \text{ mA}; V_{CE} = 5 \text{ V}$

 h_{fe} 75 to 900

D.C. current gain

$I_C = 2 \text{ mA}; V_{CE} = 5 \text{ V}$

BCV65 h_{FE} min. 75
max. 800BCV65B h_{FE} min. 200
typ. 290
max. 475

DEVELOPMENT DATA

SILICON PLANAR EPITAXIAL TRANSISTORS

N-P-N transistors, in a microminiature plastic envelope, intended for low level general purpose applications in thick and thin-film circuits.

QUICK REFERENCE DATA

		BCV71	BCV72
D.C. current gain at $T_j = 25\text{ }^\circ\text{C}$ $I_C = 2\text{ mA}; V_{CE} = 5\text{ V}$	$h_{FE} >$	110	200
	$h_{FE} <$	220	450
Collector-base voltage (open emitter)	V_{CBO} max.	80	V
Collector-emitter voltage (open base)	V_{CEO} max.	60	V
Collector current (peak value)	I_{CM} max.	200	mA
Total power dissipation up to $T_{amb} = 25\text{ }^\circ\text{C}$	P_{tot} max.	350	mW
Junction temperature	T_j max.	175	$^\circ\text{C}$
Transition frequency at $f = 35\text{ MHz}$ $I_C = 10\text{ mA}; V_{CE} = 5\text{ V}$	f_T typ.	300	MHz
	Noise figure at $R_S = 2\text{ k}\Omega$ $I_C = 200\text{ }\mu\text{A}; V_{CE} = 5\text{ V};$ $f = 1\text{ kHz}; B = 200\text{ Hz}$	F <	10

MECHANICAL DATA

Fig. 1 SOT-23.

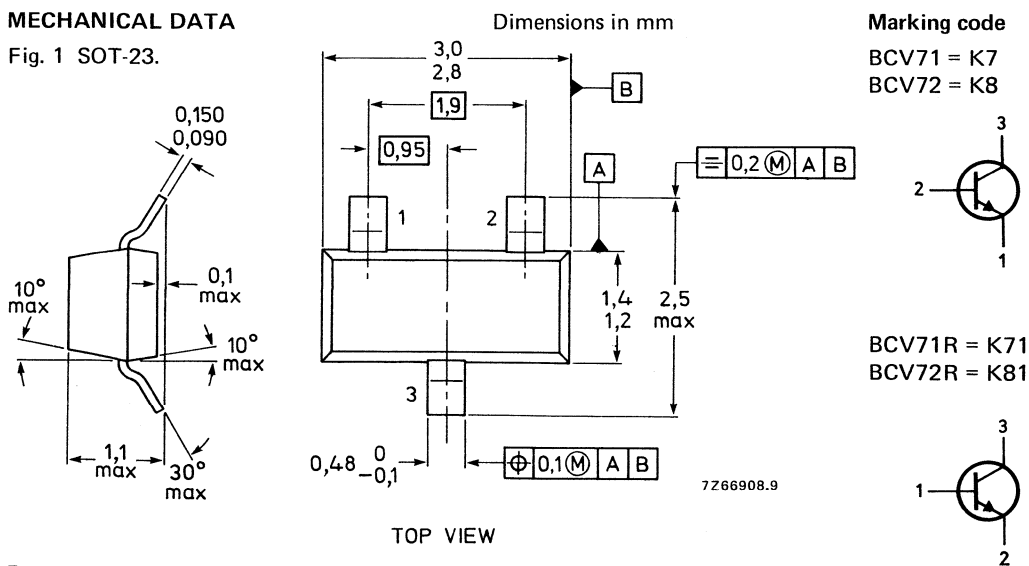

R-types are available on request

See also *Soldering recommendations*.

RATINGS

Limiting values in accordance with the Absolute Maximum System (IEC 134)

Collector-base voltage (open emitter) see Fig. 2	V_{CBO}	max.	80 V
Collector-emitter voltage (open base) see Fig. 2 $I_C = 2 \text{ mA}$	V_{CEO}	max.	60 V
Emitter-base voltage (open collector) see Fig. 2	V_{EBO}	max.	5 V
Collector current (d.c.)	I_C	max.	100 mA
Collector current (peak value)	I_{CM}	max.	200 mA
Total power dissipation up to $T_{amb} = 25 \text{ }^\circ\text{C}^{**}$	P_{tot}	max.	350 mW
Storage temperature	T_{stg}		-65 to + 175 $^\circ\text{C}$
Junction temperature	T_j	max.	175 $^\circ\text{C}$

THERMAL CHARACTERISTICS*

$$T_j = P_x (R_{th\ j-t} + R_{th\ t-s} + R_{th\ s-a}) + T_{amb}$$

Thermal resistance

From junction to tab	$R_{th\ j-t}$	=	50 K/W
From tab to soldering points	$R_{th\ t-s}$	=	280 K/W
From soldering points to ambient**	$R_{th\ s-a}$	=	90 K/W

CHARACTERISTICS

$T_j = 25 \text{ }^\circ\text{C}$ unless otherwise specified

Collector cut-off current

$$I_E = 0; V_{CB} = 20 \text{ V} \quad I_{CBO} < 100 \text{ nA}$$

$$I_E = 0; V_{CB} = 20 \text{ V}; T_j = 100 \text{ }^\circ\text{C} \quad I_{CBO} < 10 \text{ } \mu\text{A}$$

Base emitter voltage

$$I_C = 2 \text{ mA}; V_{CE} = 5 \text{ V} \quad V_{BE} \quad 550 \text{ to } 700 \text{ mV}$$

Saturation voltages

$$I_C = 10 \text{ mA}; I_B = 0,5 \text{ mA} \quad V_{CEsat} \quad \text{typ. } 120 \text{ mV}$$

$$< 250 \text{ mV}$$

$$I_C = 50 \text{ mA}; I_B = 2,5 \text{ mA}$$

$$V_{BEsat} \quad \text{typ. } 750 \text{ mV}$$

$$V_{CEsat} \quad \text{typ. } 210 \text{ mV}$$

$$V_{BEsat} \quad \text{typ. } 850 \text{ mV}$$

* See *Thermal characteristics*.

** Mounted on a ceramic substrate of 8 mm x 10 mm x 0,7 mm.

D.C. current gain

$I_C = 10 \mu A; V_{CE} = 5 V$

h_{FE} typ.

BCV71	BCV72
90	150
> 110	200
< 220	450

$I_C = 2 mA; V_{CE} = 5 V$

h_{FE} >
<

Collector capacitance at $f = 1 MHz$

$I_E = I_e = 0; V_{CB} = 10 V$

C_c typ.

2,5 pF ←

Transition frequency at $f = 35 MHz$

$I_C = 10 mA; V_{CE} = 5 V$

f_T typ.

300 MHz

Noise figure at $R_S = 2 k\Omega$

$I_C = 200 \mu A; V_{CE} = 5 V$

F <

10 dB

$f = 1 kHz; B = 200 Hz$

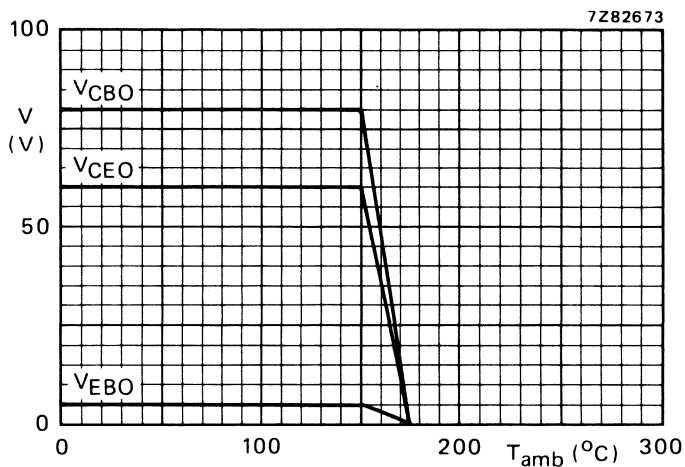

Fig. 2 Voltage derating curves.

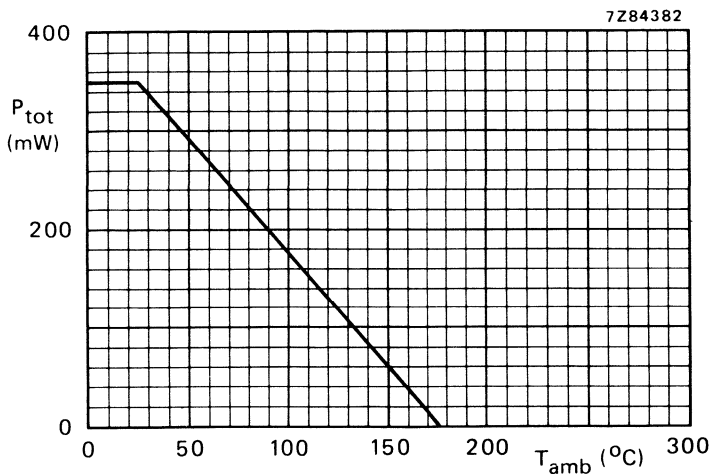

Fig. 3 Power derating curve.

SILICON PLANAR EPITAXIAL TRANSISTORS

P-N-P transistors, in a microminiature plastic envelope, intended for low level general purpose applications in thick and thin-film circuits.

QUICK REFERENCE DATA

		BCW29	BCW30
D.C. current gain at $T_j = 25\text{ }^\circ\text{C}$ $-I_C = 2\text{ mA}; -V_{CE} = 5\text{ V}$	$h_{FE} >$	120	215
	$h_{FE} <$	260	500
Collector-base voltage (open emitter)	$-V_{CBO}$ max.	32	V
Collector-emitter voltage (open base)	$-V_{CEO}$ max.	32	V
Collector current (peak value)	$-I_{CM}$ max.	200	mA
Total power dissipation up to $T_{amb} = 25\text{ }^\circ\text{C}$	P_{tot} max.	350	mW
Junction temperature	T_j max.	175	$^\circ\text{C}$
Transition frequency at $f = 35\text{ MHz}$ $-I_C = 10\text{ mA}; -V_{CE} = 5\text{ V}$	f_T typ.	150	MHz
	Noise figure at $R_S = 2\text{ k}\Omega$ $-I_C = 200\text{ }\mu\text{A}; -V_{CE} = 5\text{ V};$ $f = 1\text{ kHz}; B = 200\text{ Hz}$	F <	10

MECHANICAL DATA

Fig. 1 SOT-23.

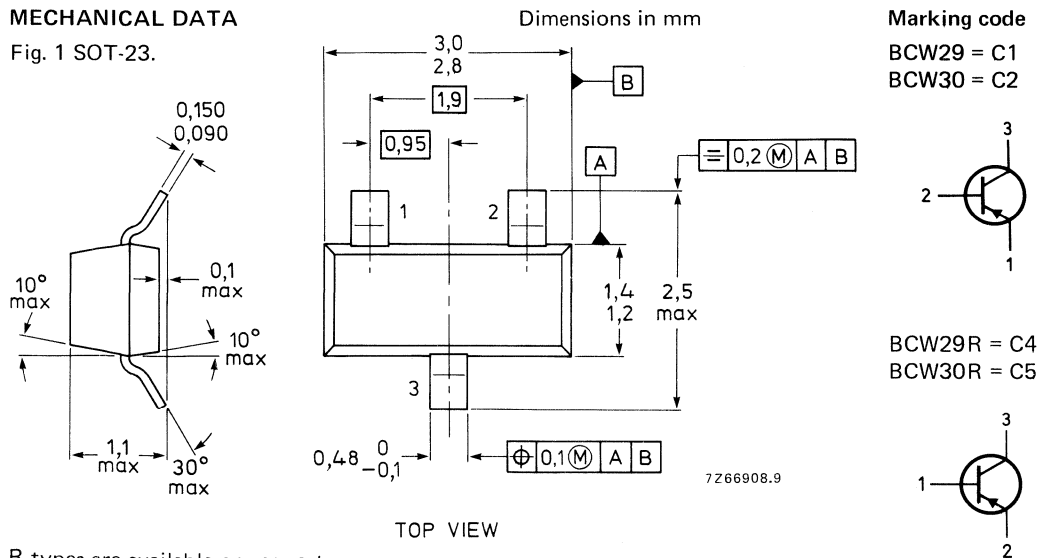

R-types are available on request

See also *Soldering recommendations*.

RATINGS

Limiting values in accordance with the Absolute Maximum System (IEC134)

Collector-base voltage (open emitter)	$-V_{CBO}$	max.	32 V
Collector-emitter voltage ($V_{BE} = 0$)	$-V_{CES}$	max.	32 V
Collector-emitter voltage (open base)			
$-I_C = 2$ mA	$-V_{CEO}$	max.	32 V
Emitter-base voltage (open collector)	$-V_{EBO}$	max.	5 V
Collector current (d.c.)	$-I_C$	max.	100 mA
Collector current (peak value)	$-I_{CM}$	max.	200 mA
Total power dissipation up to $T_{amb} = 25$ °C**	P_{tot}	max.	350 mW
Storage temperature	T_{stg}		-65 to +175 °C
Junction temperature	T_j	max.	175 °C

THERMAL CHARACTERISTICS*

$$T_j = P \times (R_{th\ j-t} + R_{th\ t-s} + R_{th\ s-a}) + T_{amb}$$

Thermal resistance

From junction to tab	$R_{th\ j-t}$	=	50 K/W
From tab to soldering points	$R_{th\ t-s}$	=	280 K/W
From soldering points to ambient**	$R_{th\ s-a}$	=	90 K/W

CHARACTERISTICS

$T_j = 25$ °C unless otherwise specified

Collector cut-off current

$$I_E = 0; -V_{CB} = 32\text{ V}$$

$$-I_{CBO} < 100\text{ nA}$$

$$I_E = 0; -V_{CB} = 32\text{ V}; T_j = 100\text{ °C}$$

$$-I_{CBO} < 10\text{ }\mu\text{A}$$

Base-emitter voltage

$$-I_C = 2\text{ mA}; -V_{CE} = 5\text{ V}$$

$$-V_{BE} \quad 600\text{ to }750\text{ mV}$$

Saturation voltages

$$-I_C = 10\text{ mA}; -I_B = 0,5\text{ mA}$$

$$-V_{CEsat} \quad \text{typ. } 80\text{ mV}$$

$$< 300\text{ mV}$$

$$-V_{BEsat} \quad \text{typ. } 720\text{ mV}$$

$$-I_C = 50\text{ mA}; -I_B = 2,5\text{ mA}$$

$$-V_{CEsat} \quad \text{typ. } 150\text{ mV}$$

$$-V_{BEsat} \quad \text{typ. } 810\text{ mV}$$

* See *Thermal characteristics*.

** Mounted on a ceramic substrate of 8 mm x 10 mm x 0,7 mm.

D.C. current gain

$-I_C = 10 \mu A; -V_{CE} = 5 V$

$-I_C = 2 mA; -V_{CE} = 5 V$

Collector-capacitance at $f = 1 MHz$

$I_E = I_e = 0; -V_{CB} = 10 V$

Transition frequency at $f = 35 MHz$

$-I_C = 10 mA; -V_{CE} = 5 V$

Noise figure at $R_S = 2 k\Omega$

$-I_C = 200 \mu A; -V_{CE} = 5 V$

$f = 1 kHz; B = 200 Hz$

	BCW29	BCW30
h_{FE}	typ. 90	150
h_{FE}	> 120	215
h_{FE}	< 260	500
C_c	typ. 4,5	pF ←
f_T	typ. 150	MHz
F	< 10	dB

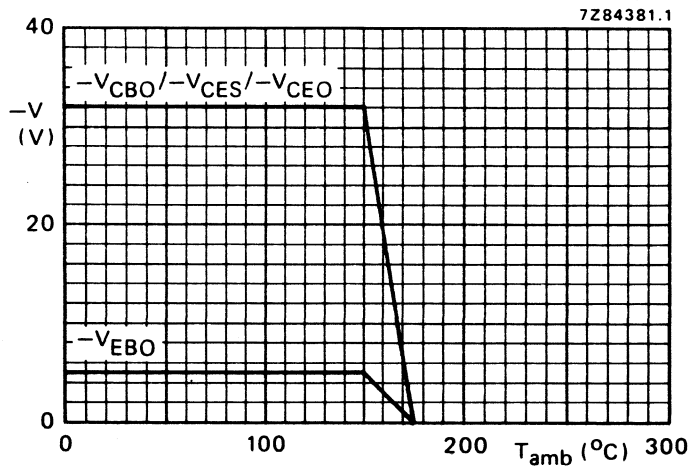

Fig. 2 Voltage derating curves.

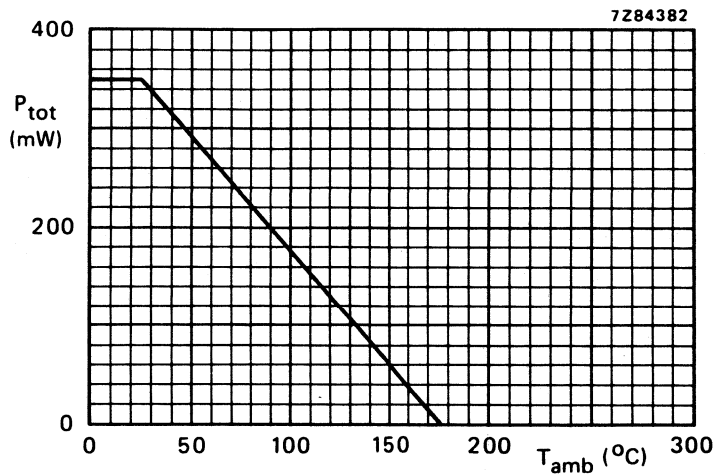

Fig. 3 Power derating curve.

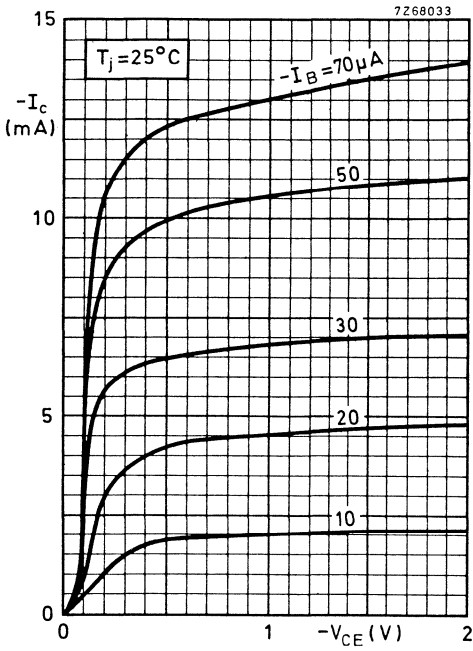

Fig. 4.

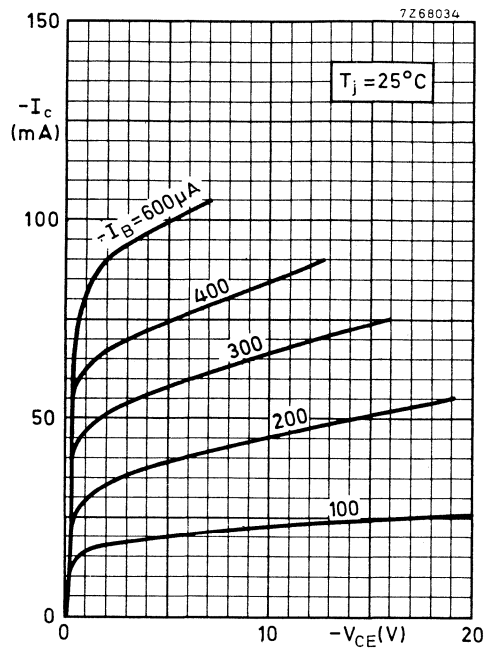

Fig. 5.

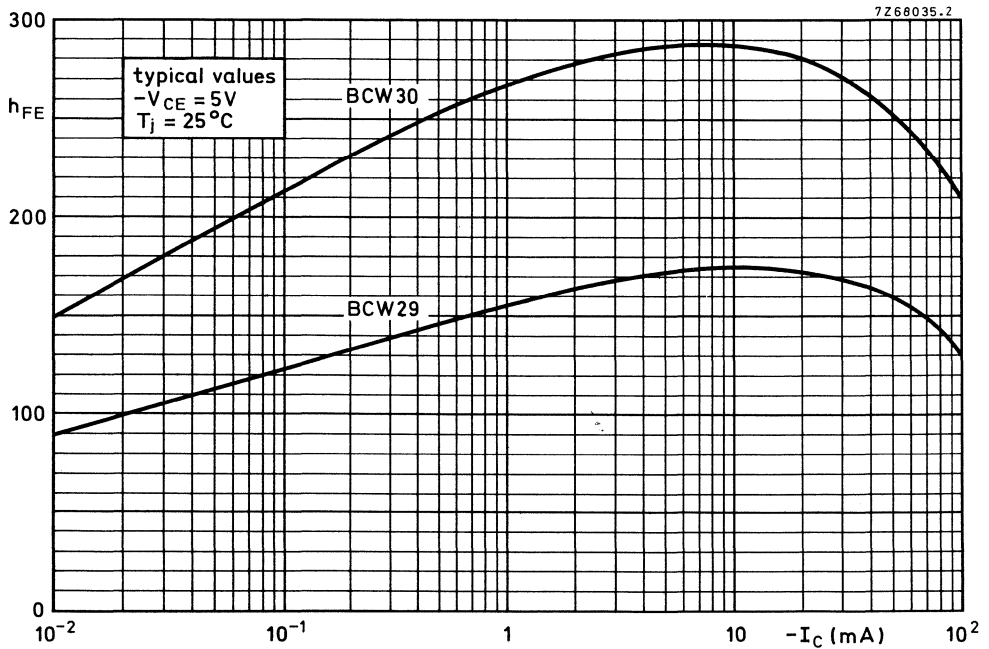

Fig. 6.

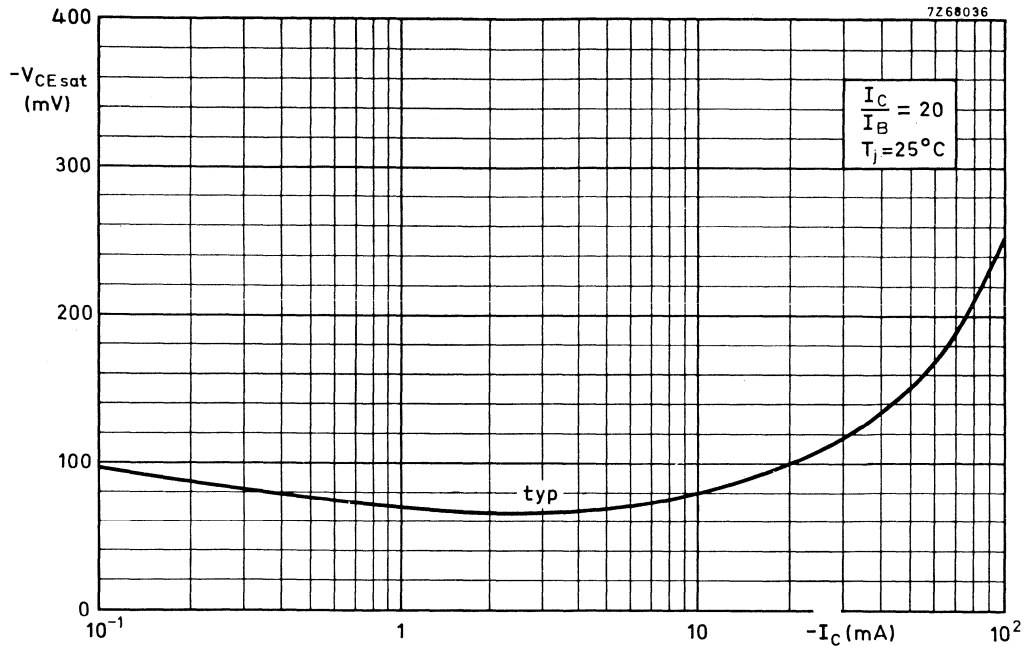

Fig. 7.

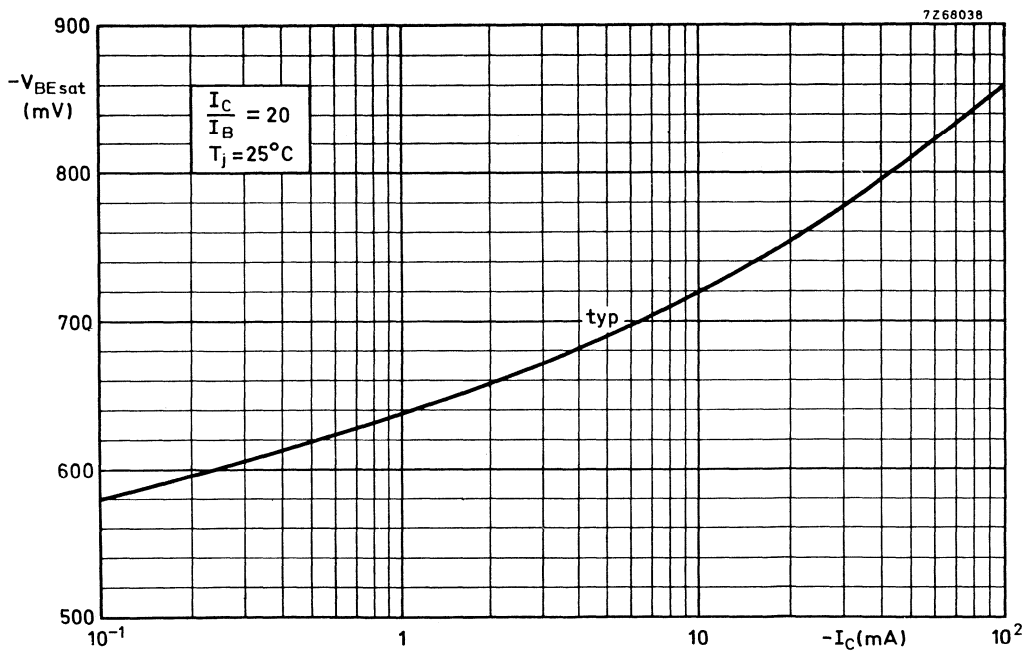

Fig. 8.

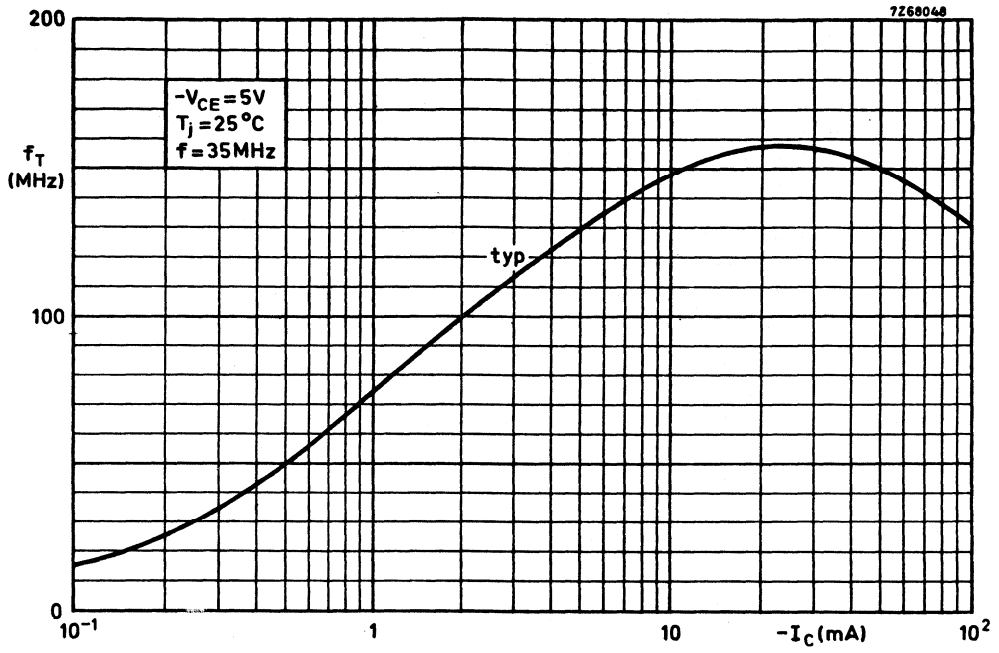

Fig. 9.

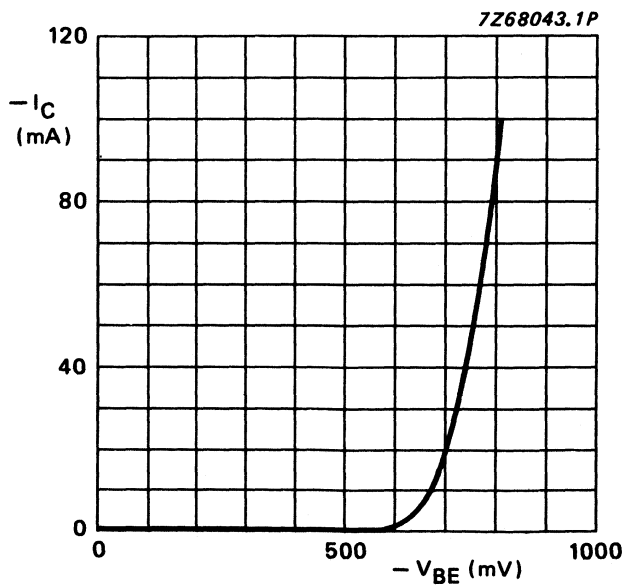

Fig. 10 $V_{CE} = 5V$; $T_j = 25^\circ C$; typical values.

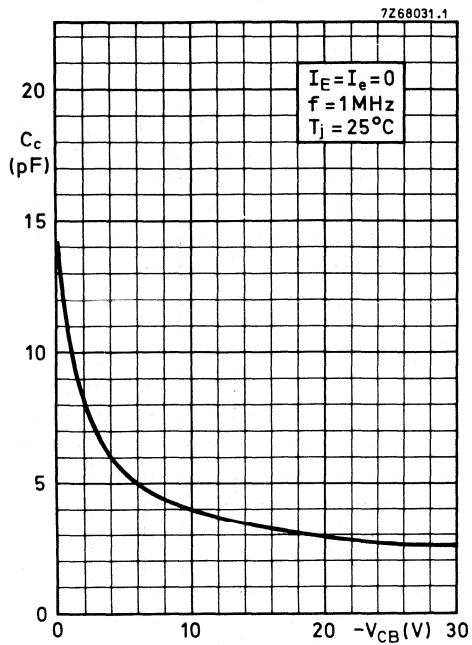

Fig. 11.

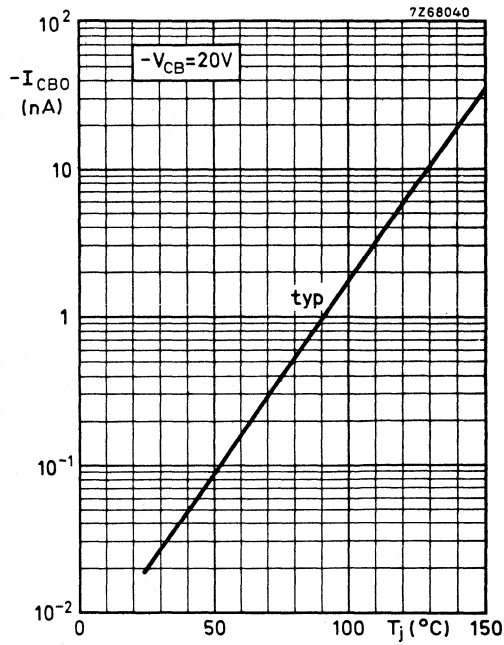

Fig. 12.

SILICON PLANAR EPITAXIAL TRANSISTORS

N-P-N transistors in a microminiature plastic envelope. They are intended for low level general purpose applications in thick and thin-film circuits.

QUICK REFERENCE DATA

		BCW31	BCW32	BCW33
D.C. current gain at $T_j = 25\text{ }^\circ\text{C}$ $I_C = 2\text{ mA}; V_{CE} = 5\text{ V}$	$h_{FE} >$	110	200	420
	$h_{FE} <$	220	450	800
Collector-base voltage (open emitter)	V_{CBO} max.		32	V
Collector-emitter voltage (open base)	V_{CEO} max.		32	V
Collector current (peak value)	I_{CM} max.		200	mA
Total power dissipation up to $T_{amb} = 25\text{ }^\circ\text{C}$	P_{tot} max.		350	mW
Junction temperature	T_j max.		175	$^\circ\text{C}$
Transition frequency at $f = 35\text{ MHz}$ $I_C = 2\text{ mA}; V_{CE} = 5\text{ V}$	f_T typ.		300	MHz
Noise figure at $R_S = 2\text{ k}\Omega$ $I_C = 200\text{ }\mu\text{A}; V_{CE} = 5\text{ V};$ $f = 1\text{ kHz}; B = 200\text{ Hz}$	F		10	dB

MECHANICAL DATA

Fig. 1 SOT-23.

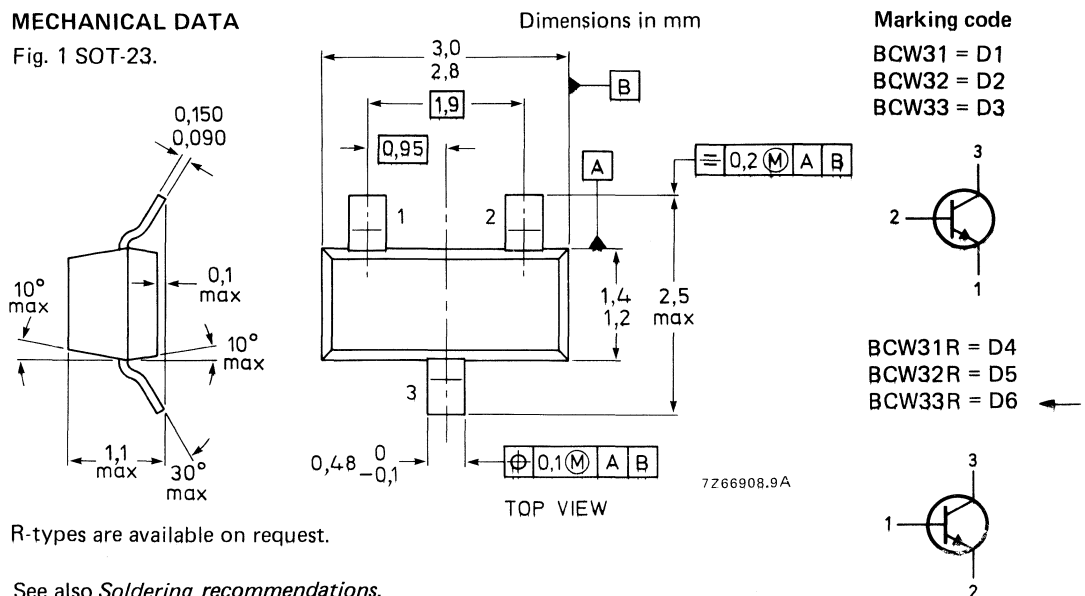

R-types are available on request.

See also *Soldering recommendations*.

RATINGS

Limiting values in accordance with the Absolute Maximum System (IEC134)

Collector-base voltage (open emitter)	V _{CBO}	max.	32 V
Collector-emitter voltage (open base) I _C = 2 mA	V _{CEO}	max.	32 V
Emitter-base voltage (open collector)	V _{EBO}	max.	5 V
Collector current (d.c.)	I _C	max.	100 mA
Collector current (peak value)	I _{CM}	max.	200 mA
Total power dissipation up to T _{amb} = 25 °C**	P _{tot}	max.	350 mW
Storage temperature	T _{stg}		-65 to +175 °C
Junction temperature	T _j	max.	175 °C

THERMAL CHARACTERISTICS*

$$T_j = P \times (R_{th\ j-t} + R_{th\ t-s} + R_{th\ s-a}) + T_{amb}$$

Thermal resistance

From junction to tab	R _{th j-t}	=	50 K/W
From tab to soldering points	R _{th t-s}	=	280 K/W
From soldering points to ambient**	R _{th s-a}	=	90 K/W

CHARACTERISTICS

T_j = 25 °C unless otherwise specified

Collector cut-off current

I _E = 0; V _{CB} = 32 V	I _{CBO}	<	100 nA
--	------------------	---	--------

I _E = 0; V _{CB} = 32 V; T _j = 100 °C	I _{CBO}	<	10 μA
---	------------------	---	-------

Base-emitter voltage

I _C = 2 mA; V _{CE} = 5 V	V _{BE}		550 to 700 mV
--	-----------------	--	---------------

Saturation voltages

	V _{CEsat}	typ.	120 mV
		<	250 mV

I _C 10 mA; I _B = 0,5 mA	V _{BEsat}	typ.	750 mV
---	--------------------	------	--------

I _C = 50 mA; I _B = 2,5 mA	V _{CEsat}	typ.	210 mV
	V _{BEsat}	typ.	850 mV

* See *Thermal characteristics*.

** Mounted on a ceramic substrate of 8 mm x 10 mm x 0,7 mm.

D.C. current gain

		BCW31	BCW32	BCW33
$I_C = 10 \mu A, V_{CE} = 5 V$	h_{FE} typ.	90	150	270
$I_C = 2 mA; V_{CE} = 5 V$	$h_{FE} >$	110	200	420
	$h_{FE} <$	220	450	800
Collector capacitance at $f = 1 MHz$ $I_E = I_e = 0; V_{CB} = 10 V$	C_c	typ.	2,5	pF ←
Transition frequency at $f = 35 MHz$ $I_C = 10 mA; V_{CE} = 5 V$	f_T	typ.	300	MHz
Noise figure at $R_S = 2 k\Omega$ $I_C = 200 \mu A; V_{CE} = 5 V$ $f = 1 kHz; B = 200 Hz$	F	<	10	dB

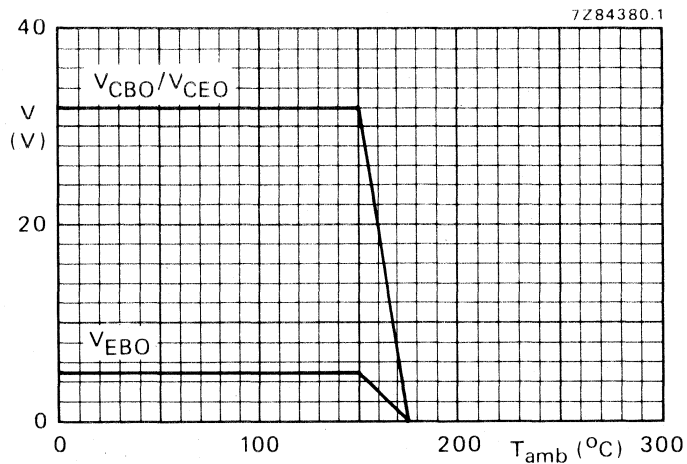

Fig. 2 Voltage derating curves.

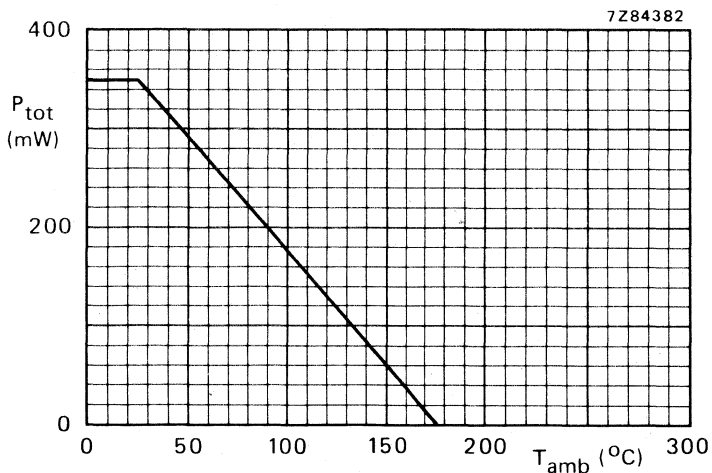

Fig. 3 Power derating curve.

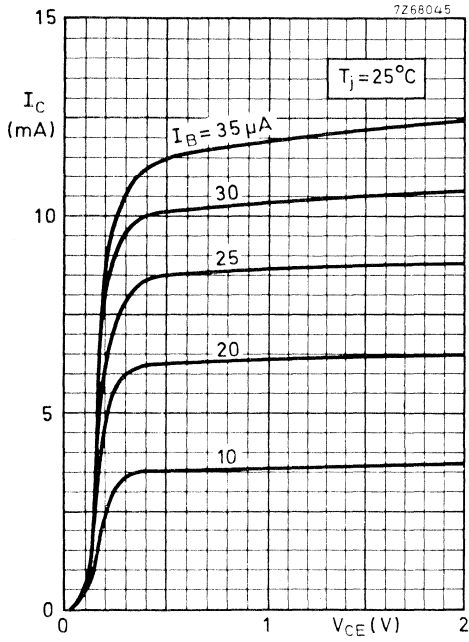

Fig. 4.

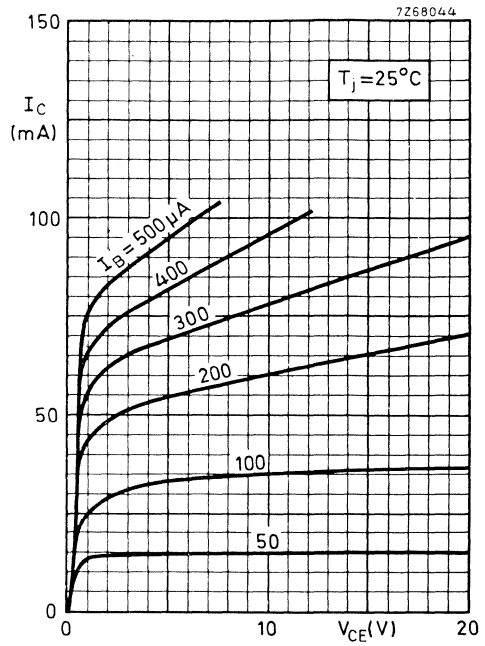

Fig. 5.

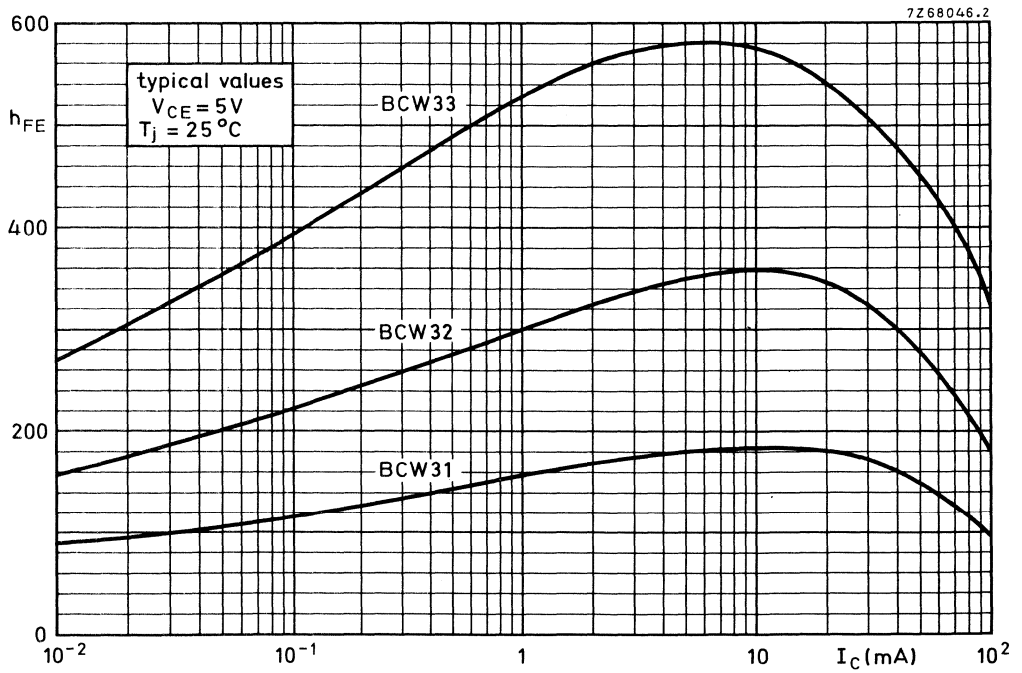

Fig. 6.

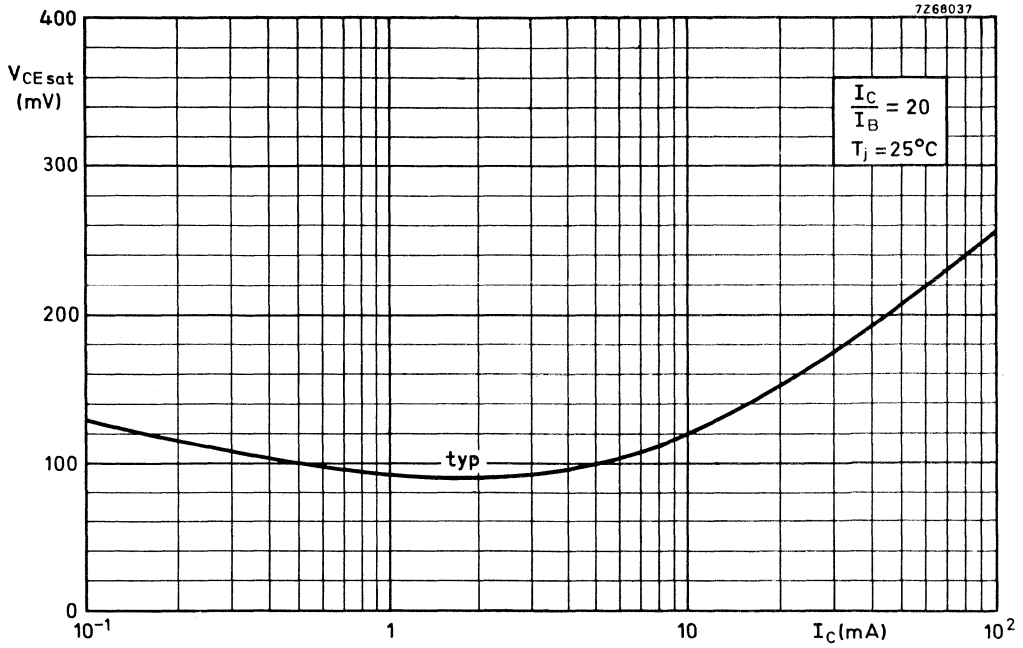

Fig. 7.

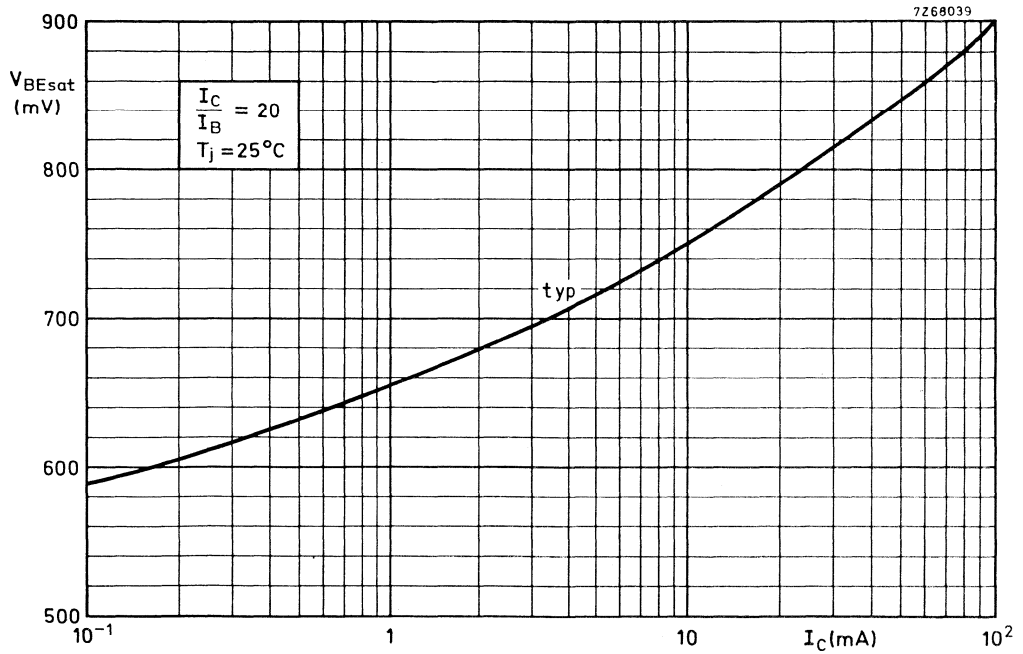

Fig. 8.

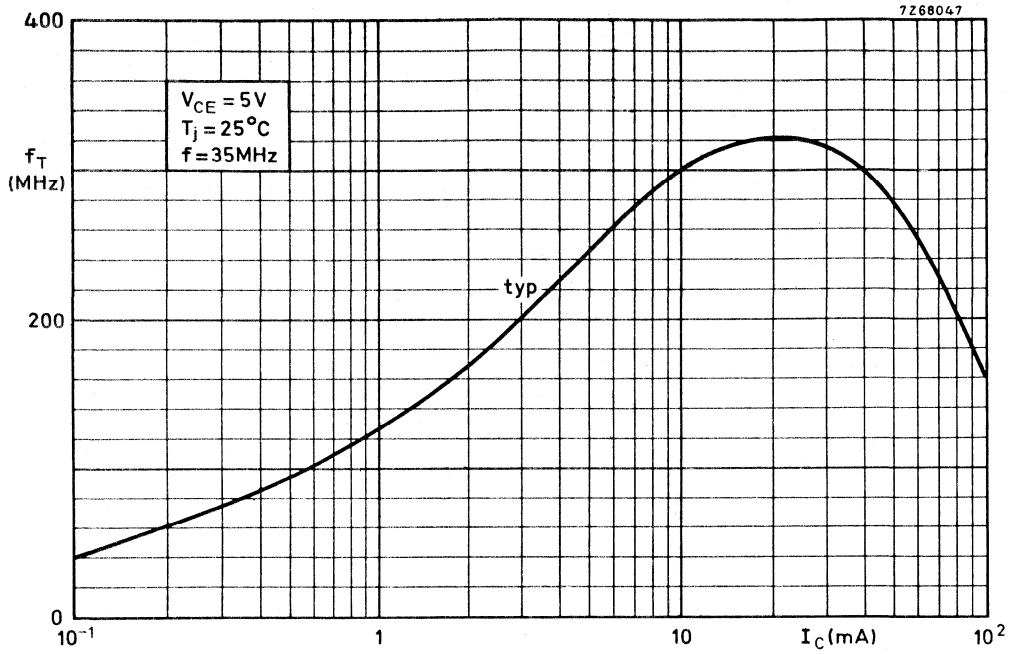

Fig. 9.

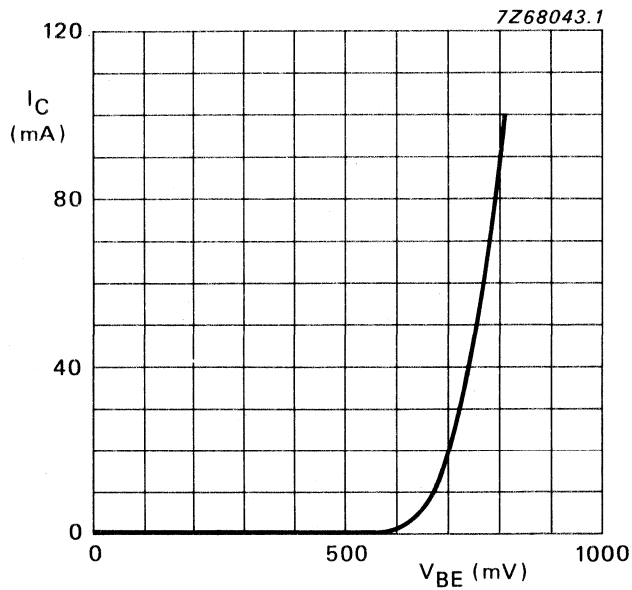

Fig. 10 $V_{CE} = 5V$; $T_j = 25^\circ C$; typical values.

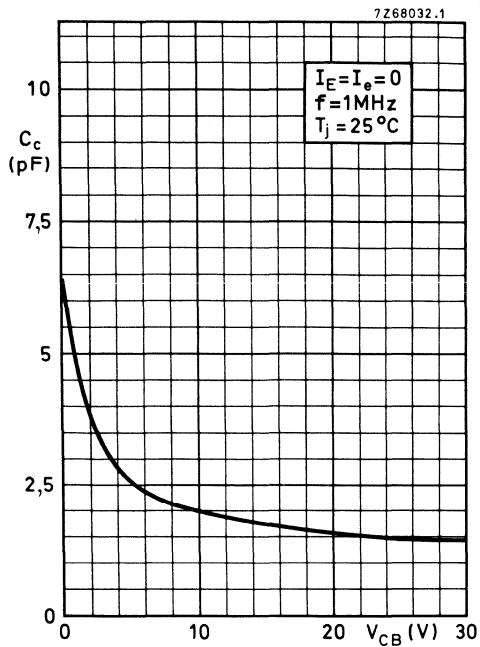

Fig. 11.

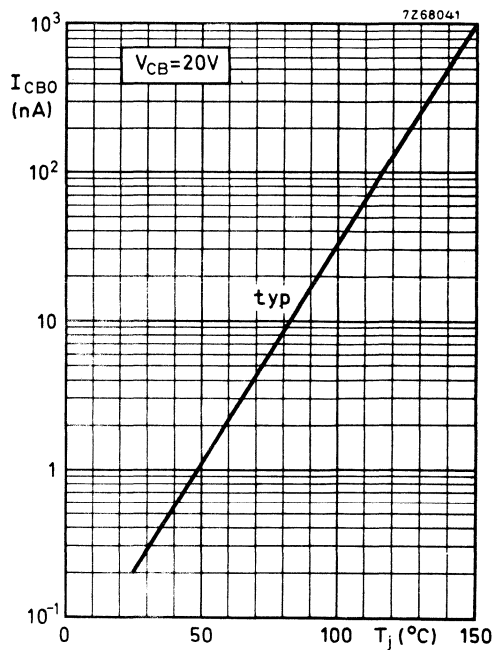

Fig. 12.

SILICON PLANAR EPITAXIAL TRANSISTORS

N-P-N silicon transistors, in a microminiature plastic envelope, intended for low level, low noise, low frequency purpose applications in hybrid circuits.

QUICK REFERENCE DATA

Collector-emitter voltage ($V_{BE} = 0$)	V_{CES}	max.	32 V
Collector-emitter voltage (open base)	V_{CEO}	max.	32 V
Collector current (d.c.)	I_C	max.	200 mA
Total power dissipation	P_{tot}	max.	150 mW
Junction temperature	T_j	max.	150 °C
Transition frequency at $f = 100$ MHz $V_{CE} = 5$ V; $I_C = 10$ mA	f_T	typ.	250 MHz
Noise figure at $f = 1$ kHz $V_{CE} = 5$ V; $I_C = 200$ μ A; $B = 200$ Hz	F	typ.	2 dB

MECHANICAL DATA

Fig. 1 SOT-23.

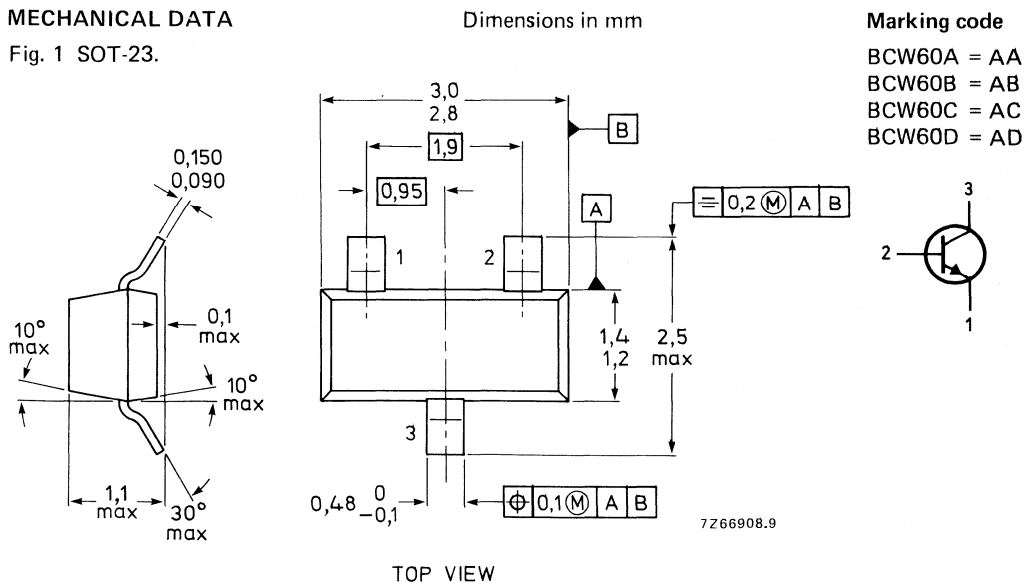

See also *Soldering recommendations*.

RATINGS

Limiting values in accordance with the Absolute Maximum System (IEC 134)

Collector-emitter voltage ($V_{BE} = 0$)	V_{CES}	max.	32 V
Collector-emitter voltage (open base)	V_{CEO}	max.	32 V
Emitter-base voltage (open collector)	V_{EBO}	max.	5 V
Collector current (d.c.)	I_C	max.	200 mA
Base current	I_B	max.	50 mA
Total power dissipation up to $T_{amb} = 100\text{ }^\circ\text{C}^{**}$	P_{tot}	max.	150 mW
Storage temperature	T_{stg}		-55 to + 125 $^\circ\text{C}$
Junction temperature	T_j	max.	150 $^\circ\text{C}$

THERMAL CHARACTERISTICS*

$$T_j = P_x (R_{th\ j-t} + R_{th\ t-s} + R_{th\ s-a}) + T_{amb}$$

Thermal resistance

From junction to tab	$R_{th\ j-t}$	=	50 K/W
From tab to soldering points	$R_{th\ t-s}$	=	280 K/W
From soldering points to ambient**	$R_{th\ s-a}$	=	90 K/W

CHARACTERISTICS

$T_{amb} = 25\text{ }^\circ\text{C}$ unless otherwise specified

Collector-emitter cut-off current

$$V_{BE} = 0; V_{CE} = 32\text{ V}$$

$$I_{CES} < 20\text{ nA}$$

$$V_{BE} = 0; V_{CE} = 32\text{ V}; T_{amb} = 150\text{ }^\circ\text{C}$$

$$I_{CES} < 20\text{ }\mu\text{A}$$

Emitter-base cut-off current

$$I_C = 0; V_{EB} = 4\text{ V}$$

$$I_{EBO} < 20\text{ nA}$$

Saturation voltages

$$\text{at } I_C = 10\text{ mA}; I_B = 0,25\text{ mA}$$

$$V_{CEsat} \quad 0,05\text{ to }0,35\text{ V}$$

$$V_{BEsat} \quad 0,6\text{ to }0,85\text{ V}$$

$$\text{at } I_C = 50\text{ mA}; I_B = 1,25\text{ mA}$$

$$V_{CEsat} \quad 0,1\text{ to }0,55\text{ V}$$

$$V_{BEsat} \quad 0,7\text{ to }1,05\text{ V}$$

Transition frequency at $f = 100\text{ MHz}$ ▲

$$I_C = 10\text{ mA}; V_{CE} = 5\text{ V}$$

$$f_T > 125\text{ MHz}$$

$$\text{typ. } 250\text{ MHz}$$

Collector capacitance at $f = 1\text{ MHz}$

$$I_E = I_e = 0; V_{CB} = 10\text{ V}$$

$$C_c \quad \text{typ. } 2,5\text{ pF}$$

Emitter capacitance at $f = 1\text{ MHz}$

$$I_C = I_c = 0; V_{EB} = 0,5\text{ V}$$

$$C_e \quad \text{typ. } 8\text{ pF}$$

Noise figure at $R_S = 2\text{ k}\Omega$

$$I_C = 200\text{ }\mu\text{A}; V_{CE} = 5\text{ V}; f = 1\text{ kHz}; B = 200\text{ Hz}$$

$$F \quad \text{typ. } 2\text{ dB}$$

$$< 6\text{ dB}$$

* See *Thermal characteristics*.

** Mounted on a ceramic substrate of 8 mm x 10 mm x 0,7 mm.

▲ Measured under pulse conditions.

		A	B	C	D	
D.C. current gain $V_{CE} = 5\text{ V}; I_C = 10\ \mu\text{A}$	h_{FE} typ.	78	145	220	300	
	$h_{FE} >$	—	20	40	100	
$V_{CE} = 5\text{ V}; I_C = 2\text{ mA}$	$h_{FE} >$	120	180	250	380	
	h_{FE} typ.	170	250	350	500	
	$h_{FE} <$	220	310	460	630	
$V_{CE} = 1\text{ V}; I_C = 50\text{ mA}$	$h_{FE} >$	50	70	90	100	
Input impedance $V_{CE} = 5\text{ V}; I_C = 2\text{ mA}; f = 1\text{ kHz}$	h_{ie} typ.	2,7	3,6	4,5	7,5 k Ω	←
Reverse voltage transfer ratio $V_{CE} = 5\text{ V}; I_C = 2\text{ mA}; f = 1\text{ kHz}$	h_{re} typ.	1,5	2	2	3 10^{-4}	
Small-signal current gain $V_{CE} = 5\text{ V}; I_C = 2\text{ mA}; f = 1\text{ kHz}$	h_{fe} typ.	200	260	330	520	←
Output admittance $V_{CE} = 5\text{ V}; I_C = 2\text{ mA}; f = 1\text{ kHz}$	h_{oe} typ.	18	24	30	50 μs	←
Base-emitter voltage $V_{CE} = 5\text{ V}; I_C = 2\text{ mA}$	V_{BE} typ.	0,55 to 0,75			V	
			0,65		V	
$V_{CE} = 5\text{ V}; I_C = 10\ \mu\text{A}$	V_{BE} typ.		0,52		V	
$V_{CE} = 1\text{ V}; I_C = 50\text{ mA}$	V_{BE} typ.		0,78		V	

Switching times

$I_{Con} = 10 \text{ mA}$; $I_{Bon} = -I_{Boff} = 1 \text{ mA}$
 $V_{CC} = 10 \text{ V}$; $R_L = 990 \Omega$

turn-on time ($t_d + t_r$)

t_{on} typ. 85 ns
 $< 150 \text{ ns}$

turn-off time ($t_s + t_f$)

t_{off} typ. 480 ns
 $< 800 \text{ ns}$

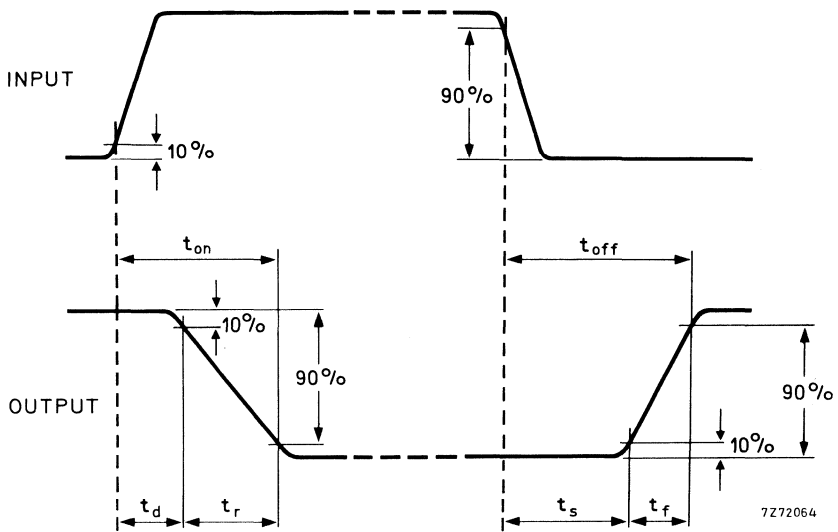

Fig. 2 Switching waveforms.

SILICON PLANAR EPITAXIAL TRANSISTORS

P-N-P silicon transistors, in a microminiature plastic envelope, intended for low level, low noise, low frequency purpose applications in hybrid circuits.

QUICK REFERENCE DATA

Collector-emitter voltage ($V_{BE} = 0$)	$-V_{CES}$	max.	32 V
Collector-emitter voltage (open base)	$-V_{CEO}$	max.	32 V
Collector current (d.c.)	$-I_C$	max.	200 mA
Total power dissipation	P_{tot}	max.	150 mW
Junction temperature	T_j	max.	150 °C
Transition frequency at $f = 100$ MHz $-V_{CE} = 5$ V; $-I_C = 10$ mA	f_T	typ.	180 MHz
Noise figure at $f = 1$ kHz $-V_{CE} = 5$ V; $-I_C = 200$ μ A	F	typ.	2 dB

MECHANICAL DATA

Fig. 1 SOT-23.

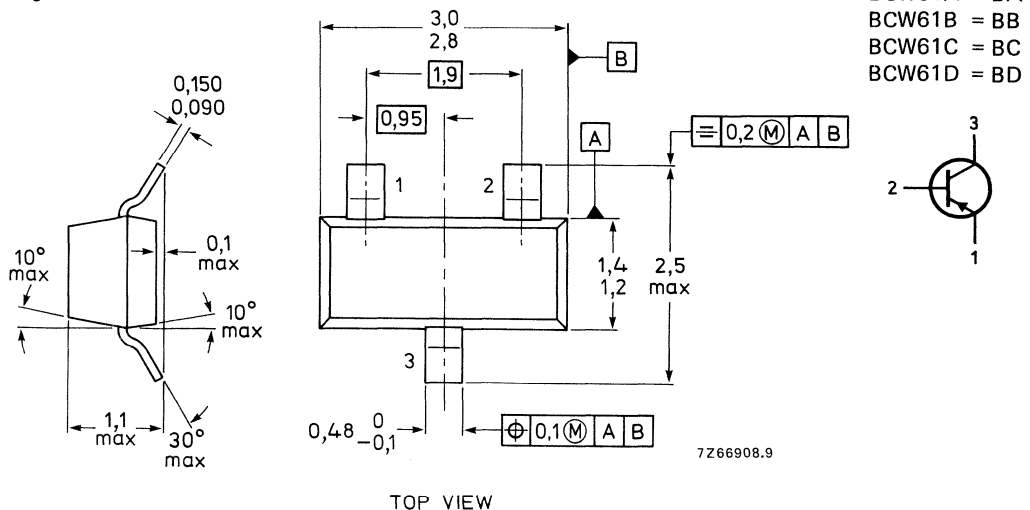

See also *Soldering recommendations*.

RATINGS

Limiting values in accordance with the Absolute Maximum System (IEC 134)

Collector-emitter voltage ($V_{BE} = 0$)	$-V_{CES}$	max.	32 V
Collector-emitter voltage (open base)	$-V_{CEO}$	max.	32 V
Emitter-base voltage (open collector)	$-V_{EBO}$	max.	5 V
Collector current (d.c.)	$-I_C$	max.	200 mA
Base current	$-I_B$	max.	50 mA
Total power dissipation up to $T_{amb} = 100\text{ }^\circ\text{C}^{**}$	P_{tot}	max.	150 mW
Storage temperature	T_{stg}		-55 to $+125\text{ }^\circ\text{C}$
Junction temperature	T_j	max.	150 $^\circ\text{C}$

THERMAL CHARACTERISTICS*

$$T_j = P_x (R_{th\ j-t} + R_{th\ t-s} + R_{th\ s-a}) + T_{amb}$$

Thermal resistance

From junction to tab	$R_{th\ j-t}$	=	50 K/W
From tab to soldering points	$R_{th\ t-s}$	=	280 K/W
From soldering points to ambient**	$R_{th\ s-a}$	=	90 K/W

CHARACTERISTICS

$T_{amb} = 25\text{ }^\circ\text{C}$ unless otherwise specified

Collector-emitter cut-off current

$$V_{EB} = 0; -V_{CE} = 32\text{ V} \quad -I_{CES} < 20\text{ nA}$$

$$V_{EB} = 0; -V_{CE} = 32\text{ V}; T_{amb} = 150\text{ }^\circ\text{C} \quad -I_{CES} < 20\text{ }\mu\text{A}$$

Emitter-base cut-off current

$$I_C = 0; -V_{EB} = 4\text{ V} \quad -I_{EBO} < 20\text{ nA}$$

Saturation voltages

$$-I_C = 10\text{ mA}; -I_B = 0,25\text{ mA} \quad -V_{CEsat} \quad 0,06\text{ to }0,25\text{ V}$$

$$-V_{BEsat} \quad 0,6\text{ to }0,85\text{ V}$$

$$-I_C = 50\text{ mA}; -I_B = 1,25\text{ mA} \quad -V_{CEsat} \quad 0,12\text{ to }0,55\text{ V}$$

$$-V_{BEsat} \quad 0,68\text{ to }1,05\text{ V}$$

Transition frequency at $f = 100\text{ MHz}$ ▲

$$-V_{CE} = 5\text{ V}; -I_C = 10\text{ mA} \quad f_T \quad \text{typ.} \quad 180\text{ MHz}$$

Collector capacitance at $f = 1\text{ MHz}$

$$-V_{CB} = 10\text{ V}; I_E = I_e = 0 \quad C_c \quad \text{typ.} \quad 4,5\text{ pF}$$

Emitter capacitance at $f = 1\text{ MHz}$

$$-V_{EB} = 0,5\text{ V}; I_C = I_c = 0 \quad C_e \quad \text{typ.} \quad 11\text{ pF}$$

Noise figure at $R_S = 2\text{ k}\Omega$

$$-V_{CE} = 5\text{ V}; -I_C = 200\text{ }\mu\text{A}; B = 200\text{ Hz} \quad F \quad \text{typ.} \quad 2\text{ dB}$$

$$< \quad 6\text{ dB}$$

* See *Thermal characteristics*.

** Mounted on a ceramic substrate of 8 mm x 10 mm x 0,7 mm.

▲ Measured under pulse conditions.

		A	B	C	D	
D.C. current gain $-V_{CE} = 5 \text{ V}; -I_C = 10 \mu\text{A}$	h_{FE} typ.	140	200	270	340	
	$h_{FE} >$	—	30	40	100	
	$h_{FE} >$	120	180	250	380	
$-V_{CE} = 5 \text{ V}; -I_C = 2 \text{ mA}$	h_{FE} typ.	170	250	350	500	
	$h_{FE} <$	220	310	460	630	
$-V_{CE} = 1 \text{ V}; -I_C = 50 \text{ mA}$	$h_{FE} >$	60	80	100	110	
Input impedance $-V_{CE} = 5 \text{ V}; -I_C = 2 \text{ mA}; f = 1 \text{ kHz}$	h_{ie} typ.	2,7	3,6	4,5	7,5 $k\Omega$	←
	Reverse voltage transfer ratio $-V_{CE} = 5 \text{ V}; -I_C = 2 \text{ mA}; f = 1 \text{ kHz}$	h_{re} typ.	1,5	2	2	$3 \cdot 10^{-4}$
Small-signal current gain $-V_{CE} = 5 \text{ V}; -I_C = 2 \text{ mA}; f = 1 \text{ kHz}$	h_{fe} typ.	200	260	330	520	←
	Output admittance $-V_{CE} = 5 \text{ V}; -I_C = 2 \text{ mA}; f = 1 \text{ kHz}$	h_{oe} typ.	18	24	30	50 μS
Base-emitter voltage $-V_{CE} = 5 \text{ V}; -I_C = 2 \text{ mA}$	V_{BE} typ.	0,6 to 0,75			V	
	V_{BE} typ.	0,65			V	
	V_{BE} typ.	0,55			V	
	V_{BE} typ.	0,72			V	

Switching times

$-I_{Con} = 10 \text{ mA}$; $-I_{Bon} = I_{Boff} = 1 \text{ mA}$
 $-V_{CC} = 10 \text{ V}$; $R_L = 990 \Omega$

turn-on time ($t_d + t_r$)	t_{on}	typ. 85 ns < 150 ns
turn-off time ($t_s + t_f$)	t_{off}	typ. 480 ns < 800 ns

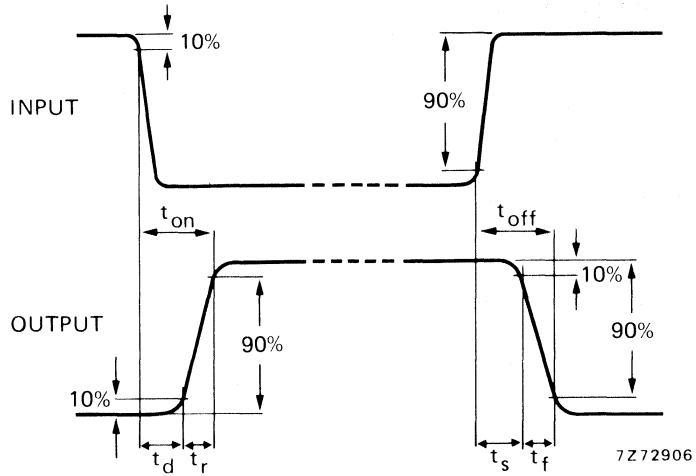

Fig. 2 Switching waveforms.

SILICON PLANAR EPITAXIAL TRANSISTORS

P-N-P transistors, in a microminiature plastic envelope, intended for low level general purpose applications in thick and thin-film circuits.

QUICK REFERENCE DATA

		BCW69	BCW70	
D.C. current gain at $T_j = 25\text{ }^\circ\text{C}$ $-I_C = 2\text{ mA}; -V_{CE} = 5\text{ V}$	$h_{FE} >$	120	215	
	$h_{FE} <$	260	500	
Collector-base voltage (open emitter)	$-V_{CBO}$ max.	50		V
Collector-emitter voltage (open base)	$-V_{CEO}$ max.	45		V
Collector current (peak value)	$-I_{CM}$ max.	200		mA
Total power dissipation up to $T_{amb} = 25\text{ }^\circ\text{C}$	P_{tot} max.	350		mW
Junction temperature	T_j max.	175		$^\circ\text{C}$
Transition frequency at $f = 35\text{ MHz}$ $-I_C = 10\text{ mA}; -V_{CE} = 5\text{ V}$	f_T typ.	150		MHz
Noise figure at $R_S = 2\text{ k}\Omega$ $-I_C = 200\text{ }\mu\text{A}; -V_{CE} = 5\text{ V};$ $f = 1\text{ kHz}; B = 200\text{ Hz}$	F	<	10	dB

MECHANICAL DATA

Fig. 1 SOT-23.

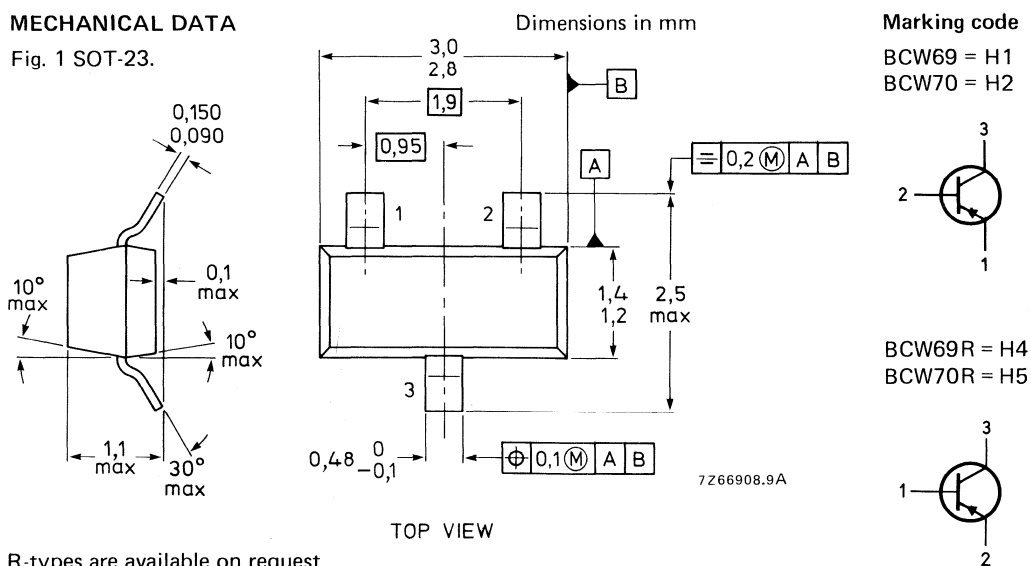

R-types are available on request.

See also *Soldering recommendations*.

RATINGS

Limiting values in accordance with the Absolute Maximum System (IEC134)

Collector-base voltage (open emitter) see Fig. 2	$-V_{CBO}$	max.	50 V
Collector-emitter voltage ($V_{BE} = 0$) see Fig. 2	$-V_{CES}$	max.	50 V
Collector-emitter voltage (open base) see Fig. 2 $-I_C = 2$ mA	$-V_{CEO}$	max.	45 V
Emitter-base voltage (open collector) see Fig. 2	$-V_{EBO}$	max.	5 V
Collector current (d.c.)	$-I_C$	max.	100 mA
Collector current (peak value)	$-I_{CM}$	max.	200 mA
Total power dissipation up to $T_{amb} = 25$ °C**	P_{tot}	max.	350 mW
Storage temperature	T_{stg}		-65 to + 175 °C
Junction temperature	T_j	max.	175 °C

THERMAL CHARACTERISTICS*

$$T_j = P \times (R_{th\ j-t} + R_{th\ t-s} + R_{th\ s-a}) + T_{amb}$$

Thermal resistance

From junction to tab	$R_{th\ j-t}$	=	50 K/W
From tab to soldering points	$R_{th\ t-s}$	=	280 K/W
From soldering points to ambient**	$R_{th\ s-a}$	=	90 K/W

CHARACTERISTICS

$T_j = 25$ °C unless otherwise specified

Collector cut-off current

$I_E = 0; -V_{CB} = 20$ V

$-I_{CBO} < 100$ nA

$I_E = 0; -V_{CB} = 20$ V; $T_j = 100$ °C

$-I_{CBO} < 10$ µA

Base-emitter voltage

$-I_C = 2$ mA; $-V_{CE} = 5$ V

$-V_{BE}$ 600 to 750 mV

Saturation voltages

$-V_{CEsat}$ typ. 80 mV

< 300 mV

$-I_C = 10$ mA; $-I_B = 0,5$ mA

$-V_{BEsat}$ typ. 720 mV

$-I_C = 50$ mA; $-I_B = 2,5$ mA

$-V_{CEsat}$ typ. 150 mV

$-V_{BEsat}$ typ. 810 mV

* See *Thermal characteristics*.

** Mounted on a ceramic substrate of 8 mm x 10 mm x 0,7 mm.

D.C. current gain

$-I_C = 10 \mu A; -V_{CE} = 5 V$

$-I_C = 2 mA; -V_{CE} = 5 V$

Collector capacitance at $f = 1 MHz$

$I_E = I_e = 0; -V_{CB} = 10 V$

Transition frequency at $f = 35 MHz$

$-I_C = 10 mA; -V_{CE} = 5 V$

Noise figure at $R_S = 2 k\Omega$

$-I_C = 200 \mu A; -V_{CE} = 5 V$

$f = 1 kHz; B = 200 Hz$

		BCW69	BCW70	
h_{FE}	typ.	90	150	
h_{FE}	>	120	215	
h_{FE}	<	260	500	
C_c	typ.	4,5	pF	←
f_T	typ.	150	MHz	
F	<	10	dB	

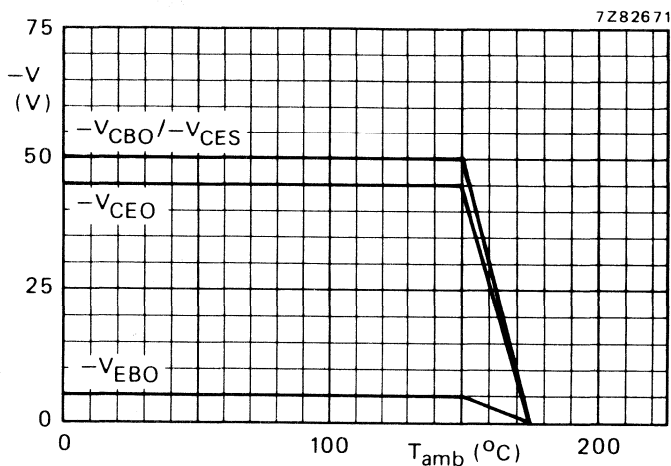

Fig. 2 Voltage derating curve.

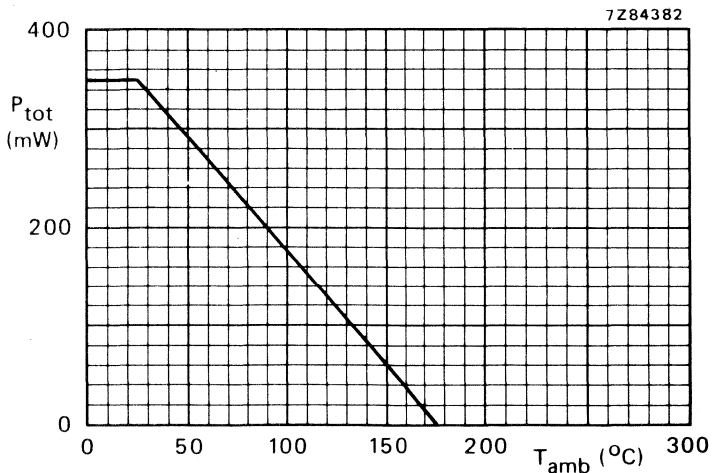

Fig. 3 Power derating curve.

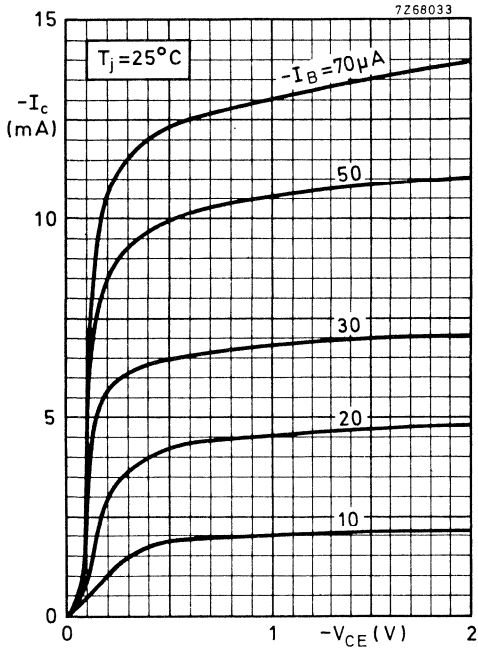

Fig. 4.

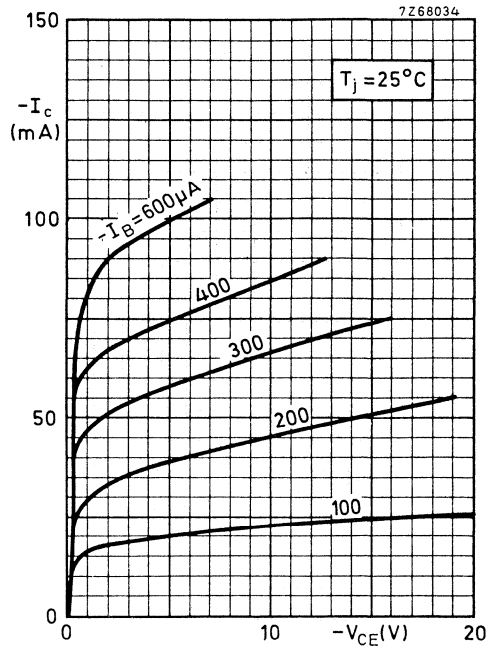

Fig. 5.

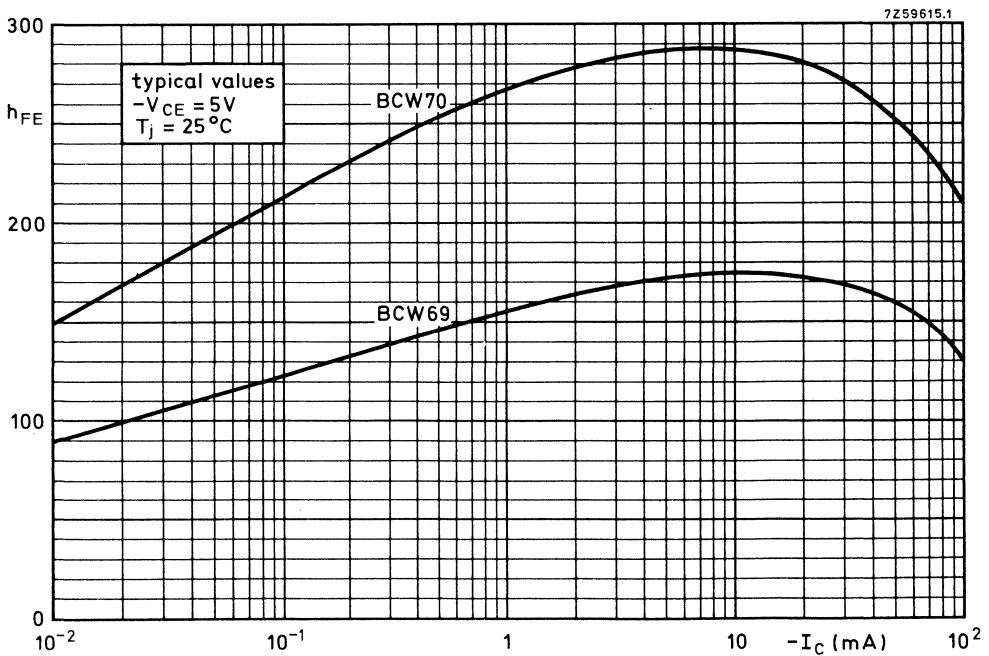

Fig. 6 D.C. current gain.

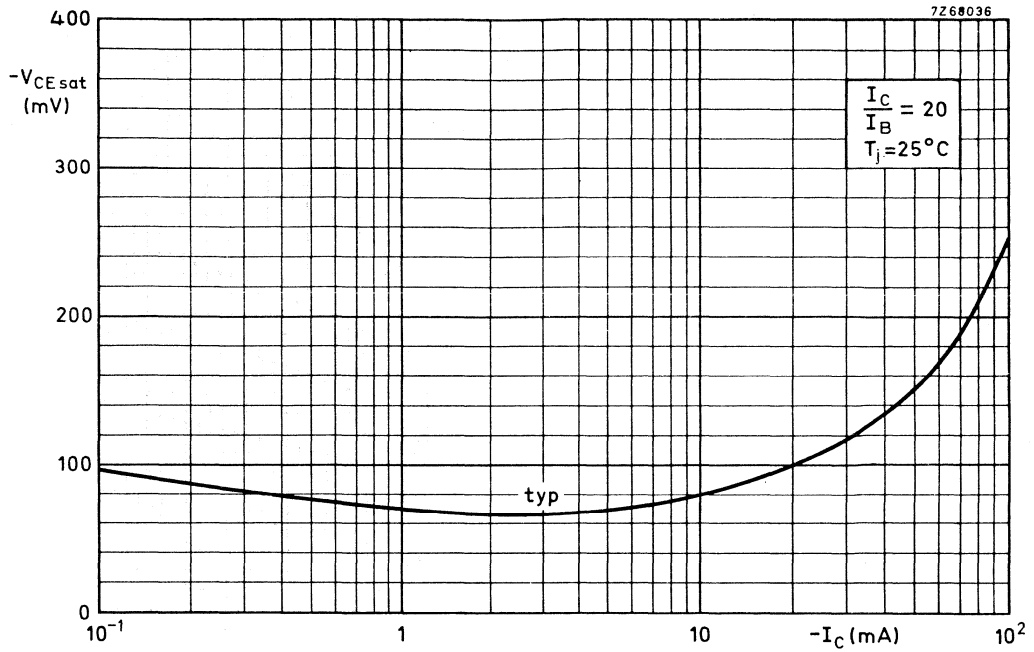

Fig. 7.

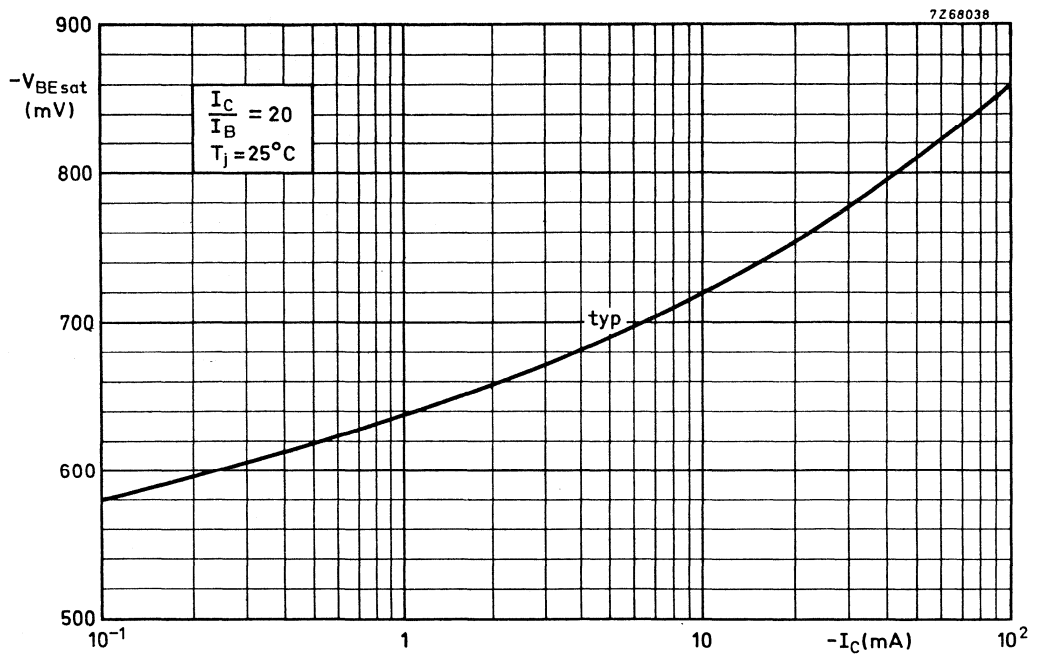

Fig. 8.

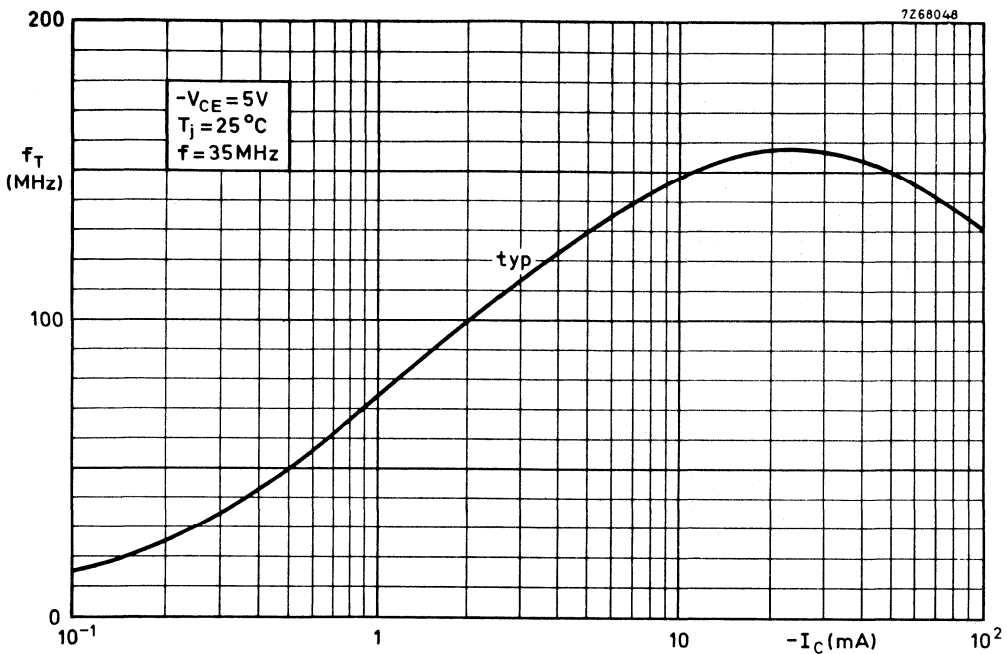

Fig. 9.

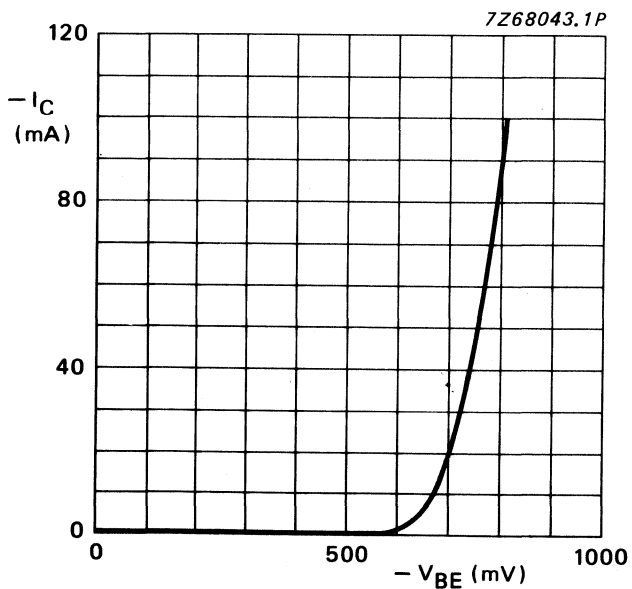

Fig. 10; $-V_{CE} = 5V$; $T_j = 25^\circ C$; typical values.

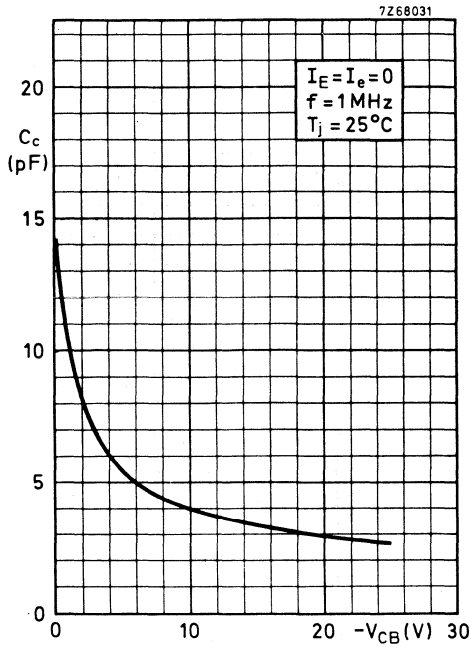

Fig. 11.

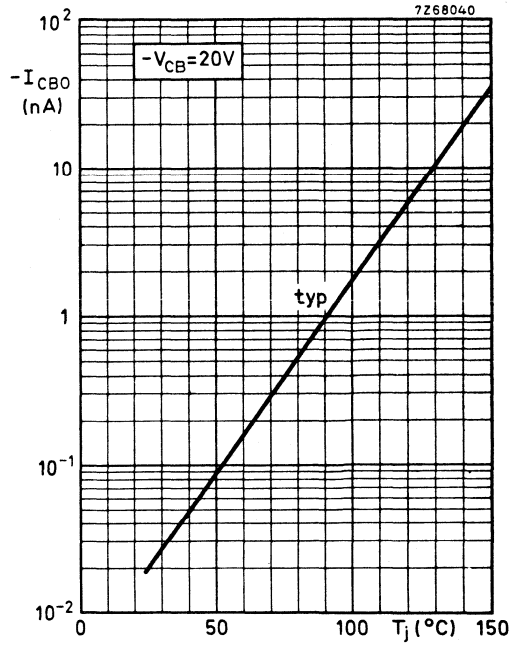

Fig. 12.

SILICON PLANAR EPITAXIAL TRANSISTORS

N-P-N transistors, in a microminiature plastic envelope, intended for low level general purpose applications in thick and thin-film circuits.

QUICK REFERENCE DATA

		BCW71	BCW72
D.C. current gain at $T_j = 25\text{ }^\circ\text{C}$ $I_C = 2\text{ mA}; V_{CE} = 5\text{ V}$	$h_{FE} >$	110	200
	$h_{FE} <$	220	450
Collector-base voltage (open emitter)	V_{CBO} max.	50	V
Collector-emitter voltage (open base)	V_{CEO} max.	45	V
Collector current (peak value)	I_{CM} max.	200	mA
Total power dissipation up to $T_{amb} = 25\text{ }^\circ\text{C}$	P_{tot} max.	350	mW
Junction temperature	T_j max.	175	$^\circ\text{C}$
Transition frequency at $f = 35\text{ MHz}$ $I_C = 10\text{ mA}; V_{CE} = 5\text{ V}$	f_T typ.	300	MHz
	Noise figure at $R_S = 2\text{ k}\Omega$ $I_C = 200\text{ }\mu\text{A}; V_{CE} = 5\text{ V};$ $f = 1\text{ kHz}; B = 200\text{ Hz}$	F <	10

MECHANICAL DATA

Fig. 1 SOT-23.

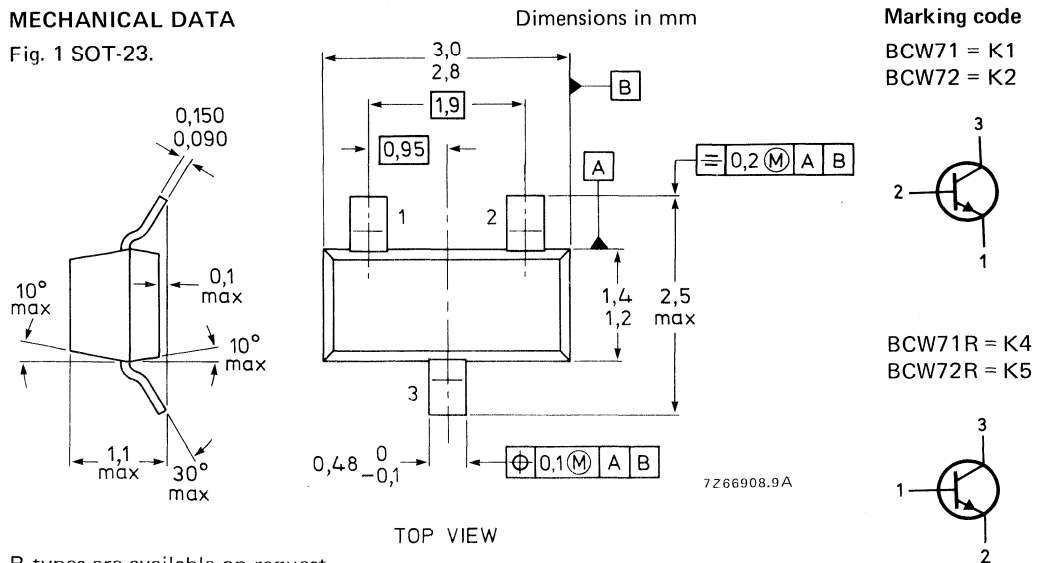

R-types are available on request.

See also *Soldering recommendations*.

RATINGS

Limiting values in accordance with the Absolute Maximum System (IEC 134)

Collector-base voltage (open emitter) see Fig. 2	V_{CBO}	max.	50 V
Collector-emitter voltage (open base) see Fig. 2 $I_C = 2 \text{ mA}$	V_{CEO}	max.	45 V
Emitter-base voltage (open collector) see Fig. 2	V_{EBO}	max.	5 V
Collector current (d.c.)	I_C	max.	100 mA
Collector current (peak value)	I_{CM}	max.	200 mA
Total power dissipation up to $T_{amb} = 25 \text{ }^\circ\text{C}^{**}$	P_{tot}	max.	350 mW
Storage temperature	T_{stg}		-65 to +175 $^\circ\text{C}$
Junction temperature	T_j	max.	175 $^\circ\text{C}$

THERMAL CHARACTERISTICS*

$$T_j = P \times (R_{th\ j-t} + R_{th\ t-s} + R_{th\ s-a}) + T_{amb}$$

Thermal resistance

From junction to tab	$R_{th\ j-t}$	=	50 K/W
From tab to soldering points	$R_{th\ t-s}$	=	280 K/W
From soldering points to ambient**	$R_{th\ s-a}$	=	90 K/W

CHARACTERISTICS

$T_j = 25 \text{ }^\circ\text{C}$ unless otherwise specified

Collector cut-off current

$$I_E = 0; V_{CB} = 20 \text{ V}$$

$$I_{CBO} < 100 \text{ nA}$$

$$I_E = 0; V_{CB} = 20 \text{ V}; T_j = 100 \text{ }^\circ\text{C}$$

$$I_{CBO} < 10 \text{ } \mu\text{A}$$

Base emitter voltage

$$I_C = 2 \text{ mA}; V_{CE} = 5 \text{ V}$$

$$V_{BE} \quad 550 \text{ to } 700 \text{ mV}$$

Saturation voltages

$$I_C = 10 \text{ mA}; I_B = 0,5 \text{ mA}$$

$$V_{CEsat} \quad \text{typ.} \quad 120 \text{ mV}$$

$$V_{CEsat} < 250 \text{ mV}$$

$$I_C = 50 \text{ mA}; I_B = 2,5 \text{ mA}$$

$$V_{BEsat} \quad \text{typ.} \quad 750 \text{ mV}$$

$$V_{CEsat} \quad \text{typ.} \quad 210 \text{ mV}$$

$$V_{BEsat} \quad \text{typ.} \quad 850 \text{ mV}$$

* See *Thermal characteristics*.

** Mounted on a ceramic substrate of 8 mm x 10 mm x 0,7 mm.

D.C. current gain

$I_C = 10 \mu A; V_{CE} = 5 V$

$I_C = 2 mA; V_{CE} = 5 V$

Collector capacitance at $f = 1 MHz$

$I_E = I_e = 0; V_{CB} = 10 V$

Transition frequency at $f = 35 MHz$

$I_C = 10 mA; V_{CE} = 5 V$

Noise figure at $R_S = 2 k\Omega$

$I_C = 200 \mu A; V_{CE} = 5 V$

$f = 1 kHz; B = 200 Hz$

		BCW71	BCW72	
h_{FE}	typ.	90	150	
h_{FE}	>	110	200	
h_{FE}	<	220	450	
C_c	typ.	2,5	pF	←
f_T	typ.	300	MHz	
F	<	10	dB	

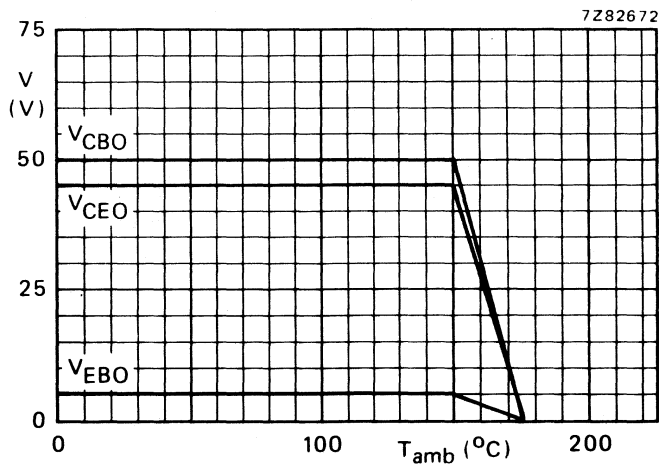

Fig. 2 Voltage derating curves.

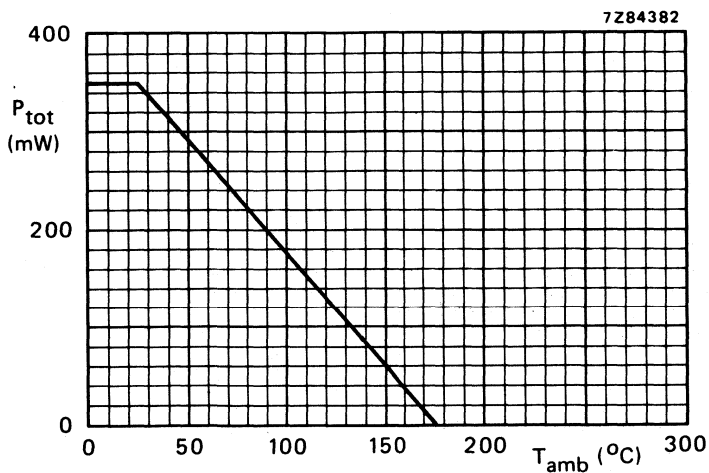

Fig. 3 Power derating curve.

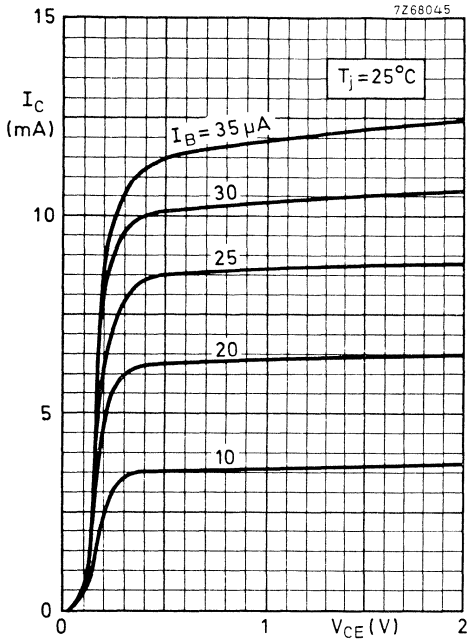

Fig. 4.

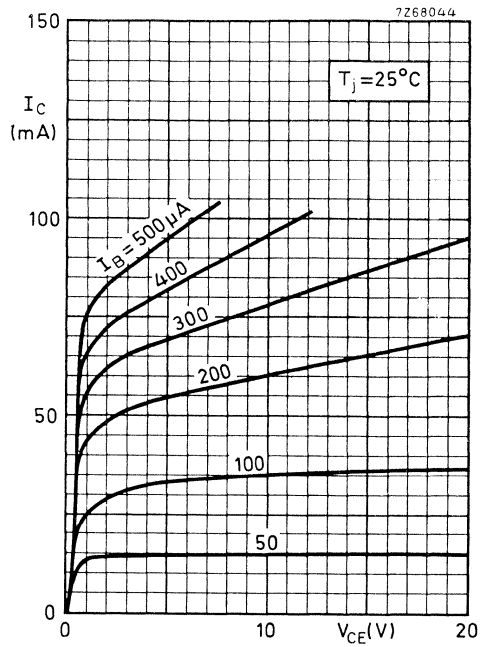

Fig. 5.

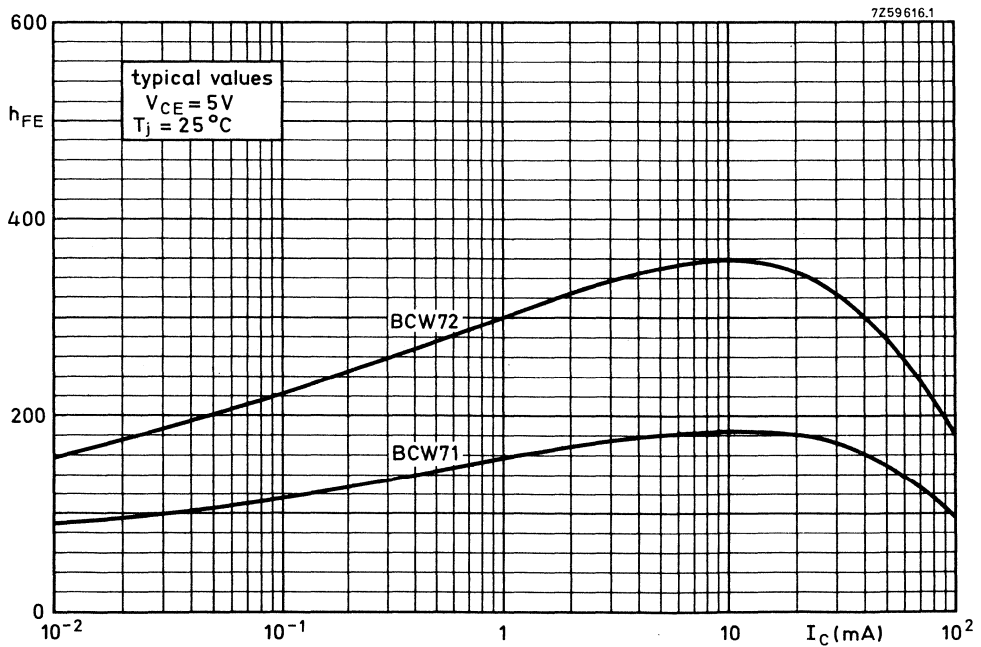

Fig. 6 D.C. current gain.

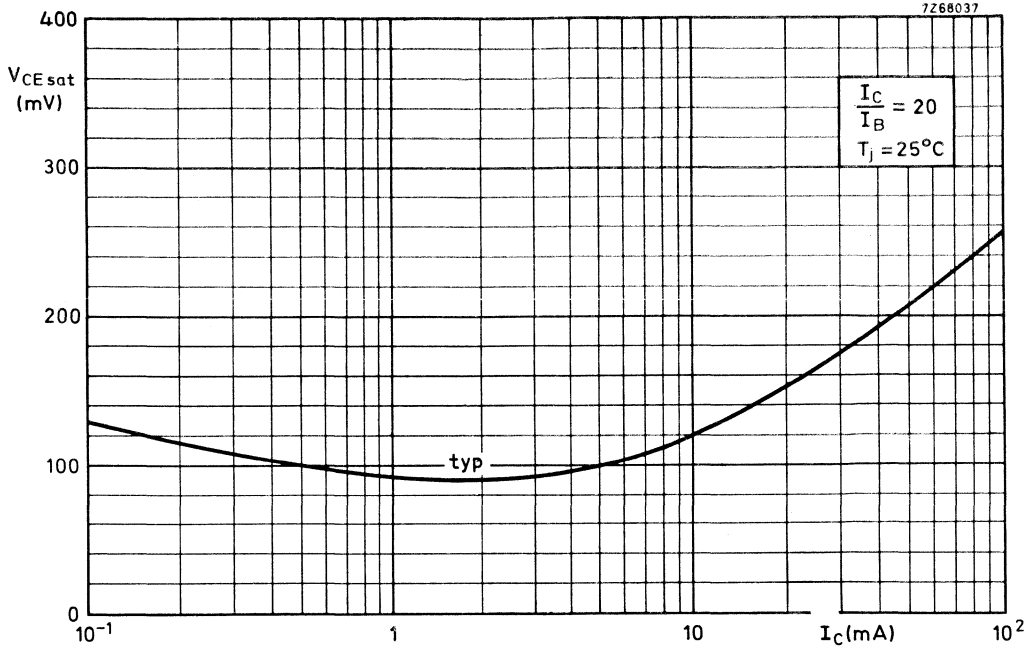

Fig. 7.

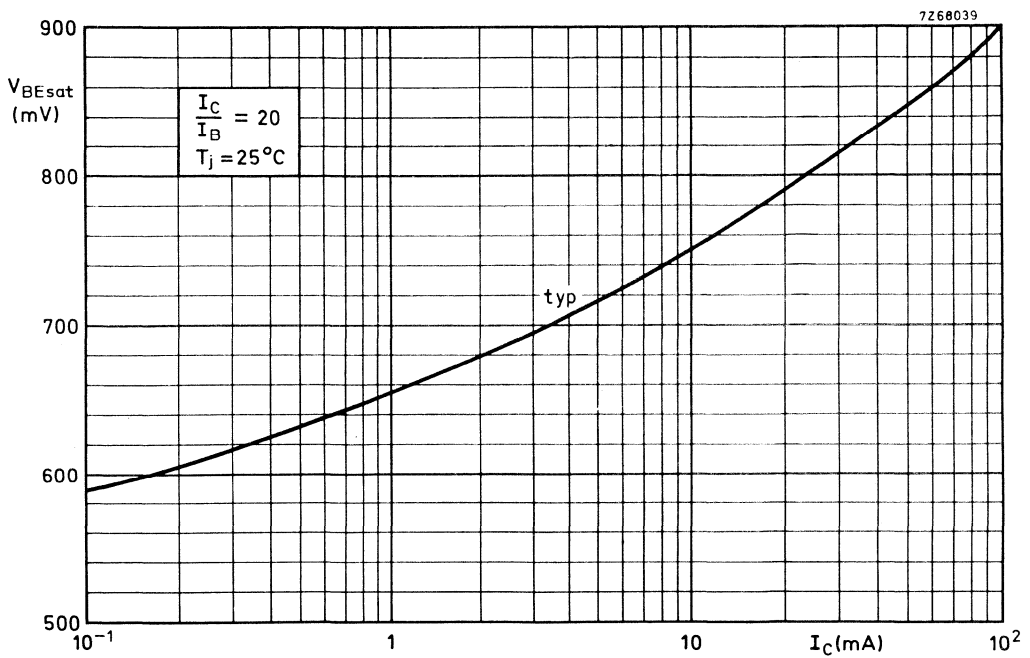

Fig. 8.

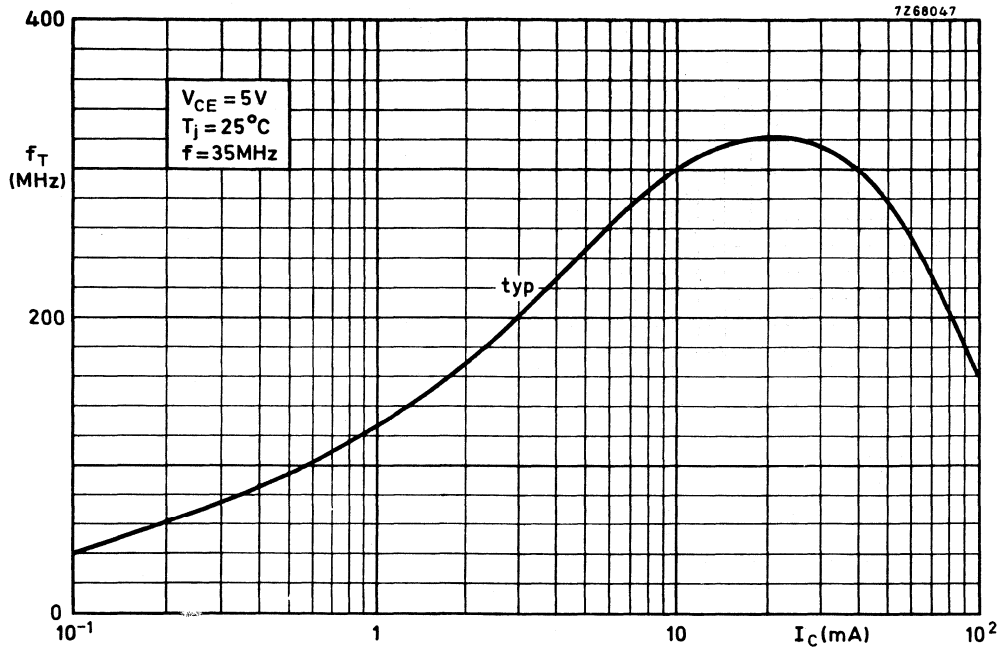

Fig. 9.

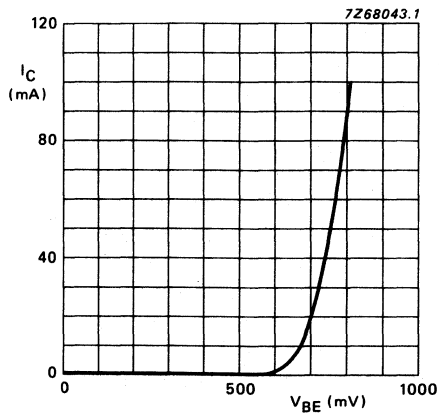

Fig. 10 $V_{CE} = 5V$; $T_j = 25^\circ C$; typical values.

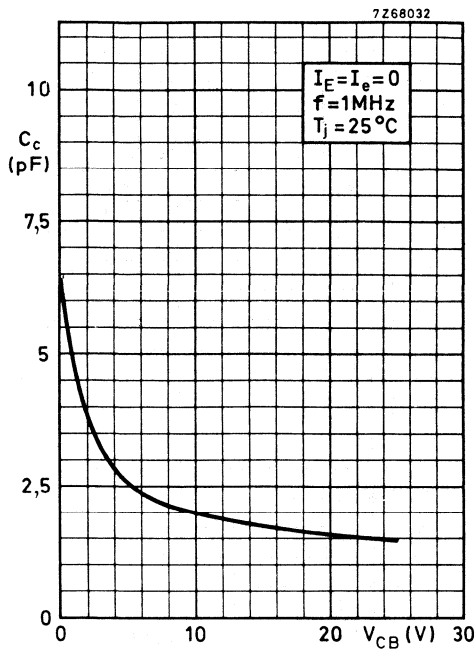

Fig. 11.

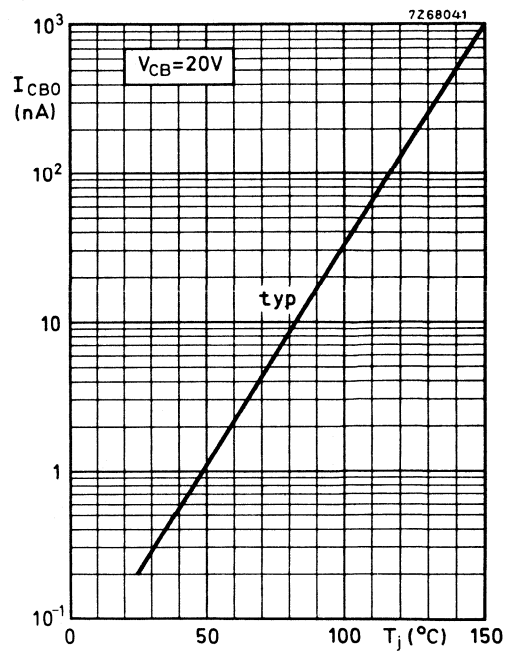

Fig. 12.

SILICON PLANAR EPITAXIAL TRANSISTORS

N-P-N transistors, in a microminiature plastic envelope, intended for low level general purpose applications in thick and thin-film circuits.

QUICK REFERENCE DATA

Collector-base voltage (open emitter)	V_{CBO}	max.	50 V
Collector-emitter voltage (open base)	V_{CE0}	max.	45 V
Collector current (peak value)	I_{CM}	max.	200 mA
Total power dissipation up to $T_{amb} = 25\text{ }^{\circ}\text{C}$	P_{tot}	max.	350 mW
Junction temperature	T_j	max.	175 $^{\circ}\text{C}$
D.C. current gain at $T_j = 25\text{ }^{\circ}\text{C}$ $I_C = 2\text{ mA}$; $V_{CE} = 5\text{ V}$	h_{FE}	>	420
		<	800
Transition frequency at $f = 35\text{ MHz}$ $I_C = 10\text{ mA}$; $V_{CE} = 5\text{ V}$	f_T	typ.	300 MHz
Noise figure at $R_S = 2\text{ k}\Omega$ $I_C = 200\text{ }\mu\text{A}$; $V_{CE} = 5\text{ V}$; $f = 1\text{ kHz}$; $B = 200\text{ Hz}$	F	<	10 dB

MECHANICAL DATA

Fig. 1 SOT-23.

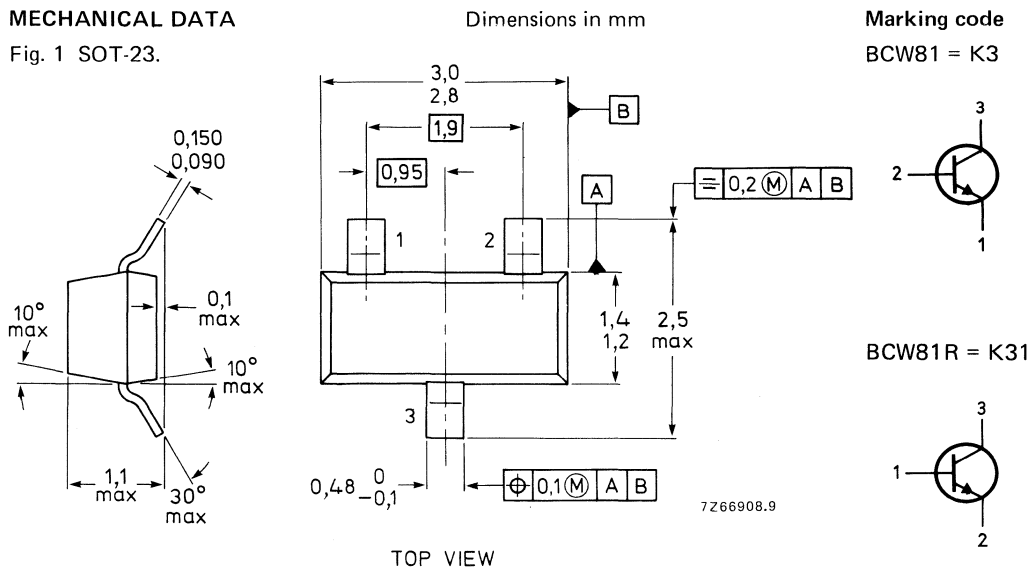

R-types are available on request

See also *Soldering recommendations*.

RATINGS

Limiting values in accordance with the Absolute Maximum System (IEC 134)

Collector-base voltage (open emitter) see Fig. 2	V_{CBO}	max.	50 V
Collector-emitter voltage (open base) see Fig. 2 $I_C = 2 \text{ mA}$	V_{CEO}	max.	45 V
Emitter-base voltage (open collector) see Fig. 2	V_{EBO}	max.	5 V
Collector current (d.c.)	I_C	max.	100 mA
Collector current (peak value)	I_{CM}	max.	200 mA
Total power dissipation up to $T_{amb} = 25 \text{ }^\circ\text{C}^{**}$	P_{tot}	max.	350 mW
Storage temperature	T_{stg}		-65 to + 175 $^\circ\text{C}$
Junction temperature	T_j	max.	175 $^\circ\text{C}$

THERMAL CHARACTERISTICS*

$$T_j = P \times (R_{th\ j-t} + R_{th\ t-s} + R_{th\ s-a}) + T_{amb}$$

Thermal resistance

From junction to tab	$R_{th\ j-t}$	=	50 K/W
From tab to soldering points	$R_{th\ t-s}$	=	280 K/W
From soldering points to ambient**	$R_{th\ s-a}$	=	90 K/W

CHARACTERISTICS $T_j = 25 \text{ }^\circ\text{C}$ unless otherwise specified

Collector cut-off current $I_E = 0; V_{CB} = 20 \text{ V}$	I_{CBO}	<	100 nA
$I_E = 0; V_{CB} = 20 \text{ V}; T_j = 100 \text{ }^\circ\text{C}$	I_{CBO}	<	10 μA
Base emitter voltage $I_C = 2 \text{ mA}; V_{CE} = 5 \text{ V}$	V_{BE}		550 to 700 mV
Saturation voltages $I_C = 10 \text{ mA}; I_B = 0,5 \text{ mA}$	V_{CEsat}	typ.	120 mV
		<	250 mV
	V_{BEsat}	typ.	750 mV
	V_{CEsat}	typ.	210 mV
$I_C = 50 \text{ mA}; I_B = 2,5 \text{ mA}$	V_{BEsat}	typ.	850 mV

* See *Thermal characteristics*.

** Mounted on a ceramic substrate of 8 mm x 10 mm x 0,7 mm

D.C. current gain

$I_C = 2 \text{ mA}; V_{CE} = 5 \text{ V}$

$h_{FE} > 420$
 $h_{FE} < 800$

Collector capacitance at $f = 1 \text{ MHz}$

$I_E = I_e = 0; V_{CB} = 10 \text{ V}$

$C_c \text{ typ. } 2.5 \text{ pF}$ ←

Transition frequency at $f = 35 \text{ MHz}$

$I_C = 10 \text{ mA}; V_{CE} = 5 \text{ V}$

$f_T \text{ typ. } 300 \text{ MHz}$

Noise figure at $R_S = 2 \text{ k}\Omega$

$I_C = 200 \text{ }\mu\text{A}; V_{CE} = 5 \text{ V}$

$f = 1 \text{ kHz}; B = 200 \text{ Hz}$

$F < 10 \text{ dB}$

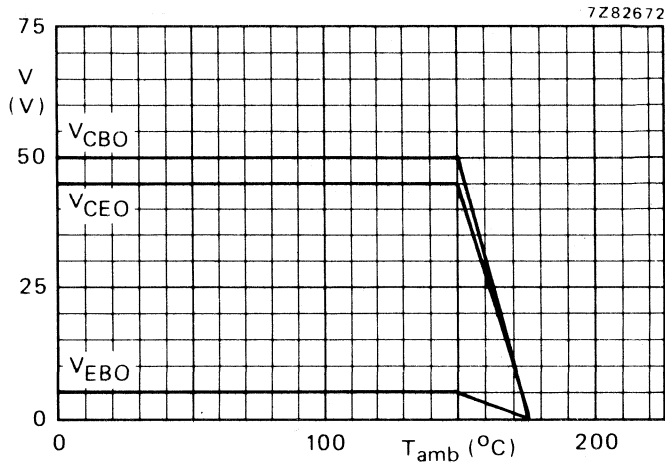

Fig. 2 Voltage derating curves.

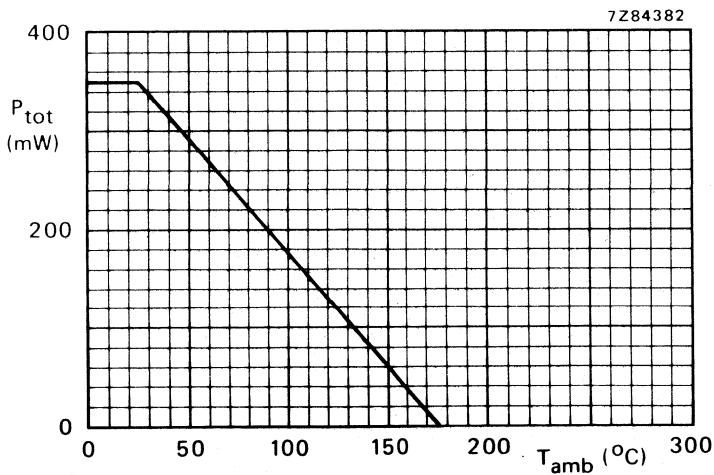

Fig. 3 Power derating curve.

SILICON PLANAR EPITAXIAL TRANSISTORS

P-N-P transistors, in a microminiature plastic envelope, intended for low level general purpose applications in thick and thin-film circuits.

QUICK REFERENCE DATA

Collector-base voltage (open emitter)	$-V_{CBO}$	max.	80 V
Collector-emitter voltage (open base)	$-V_{CE0}$	max.	60 V
Collector current (peak value)	$-I_{CM}$	max.	200 mA
Total power dissipation up to $T_{amb} = 25\text{ }^{\circ}\text{C}$	P_{tot}	max.	350 mW
Junction temperature	T_j	max.	175 $^{\circ}\text{C}$
D.C. current gain at $T_j = 25\text{ }^{\circ}\text{C}$ $-I_C = 2\text{ mA}; -V_{CE} = 5\text{ V}$	h_{FE}	$>$	120
		$<$	260
Transition frequency at $f = 35\text{ MHz}$ $-I_C = 10\text{ mA}; -V_{CE} = 5\text{ V}$	f_T	typ.	150 MHz
Noise figure at $R_S = 2\text{ k}\Omega$ $-I_C = 200\text{ }\mu\text{A}; -V_{CE} = 5\text{ V};$ $f = 1\text{ kHz}; B = 200\text{ Hz}$	F	$<$	10 dB

MECHANICAL DATA

Fig. 1 SOT-23.

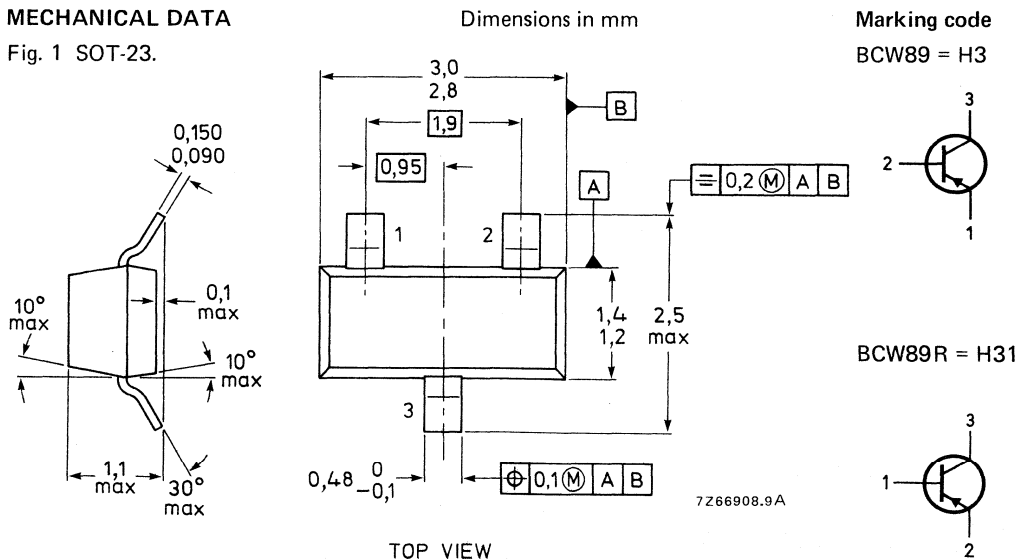

R-types are available on request.

See also *Soldering recommendations*.

RATINGS

Limiting values in accordance with the Absolute Maximum System (IEC 134)

Collector-base voltage (open emitter) see Fig. 2	$-V_{CBO}$	max.	80 V
Collector-emitter voltage ($V_{BE} = 0$) see Fig. 2	$-V_{CES}$	max.	60 V
Collector-emitter voltage (open base) see Fig. 2 $-I_C = 2$ mA	$-V_{CEO}$	max.	60 V
Emitter-base voltage (open collector) see Fig. 2	$-V_{EBO}$	max.	5 V
Collector current (d.c.)	$-I_C$	max.	100 mA
Collector current (peak value)	$-I_{CM}$	max.	200 mA
Total power dissipation up to $T_{amb} = 25$ °C**	P_{tot}	max.	350 mW
Storage temperature	T_{stg}		-65 to + 175 °C
Junction temperature	T_j	max.	175 °C

THERMAL CHARACTERISTICS*

$$T_j = P \times (R_{thj-t} + R_{tht-s} + R_{th s-a}) + T_{amb}$$

Thermal resistance

From junction to tab	R_{thj-t}	=	50 K/W
From tab to soldering points	R_{tht-s}	=	280 K/W
From soldering points to ambient**	$R_{th s-a}$	=	90 K/W

CHARACTERISTICS $T_j = 25$ °C unless otherwise specified

Collector cut-off current

$I_E = 0; -V_{CB} = 20$ V

$-I_{CBO} < 100$ nA

$I_E = 0; -V_{CB} = 20$ V; $T_j = 100$ °C

$-I_{CBO} < 10$ μ A

Base-emitter voltage

$-I_C = 2$ mA; $-V_{CE} = 5$ V; $T_j = 25$ °C

$-V_{BE}$ 600 to 750 mV

Saturation voltages

$-I_C = 10$ mA; $-I_B = 0,5$ mA

$-V_{CEsat}$ typ. 80 mV
< 300 mV

$-I_C = 50$ mA; $-I_B = 2,5$ mA

$-V_{BEsat}$ typ. 720 mV
 $-V_{CEsat}$ typ. 150 mV
 $-V_{BEsat}$ typ. 810 mV

* See *Thermal characteristics*.

** Mounted on a ceramic substrate of 8 mm x 10 mm x 0,7 mm.

D.C. current gain

$-I_C = 10 \mu A; -V_{CE} = 5 V$

h_{FE} typ. 90

$-I_C = 2 mA; -V_{CE} = 5 V$

h_{FE} $\begin{matrix} > & 120 \\ < & 260 \end{matrix}$

Collector capacitance at $f = 1 MHz$

$I_E = I_e = 0; -V_{CB} = 10 V$

C_c typ. 4,5 pF ←

Transition frequency at $f = 35 MHz$

$-I_C = 10 mA; -V_{CE} = 5 V$

f_T typ. 150 MHz

Noise figure at $R_S = 2 k\Omega$

$-I_C = 200 \mu A; -V_{CE} = 5 V$

$f = 1 kHz; B = 200 Hz$

F $<$ 10 dB

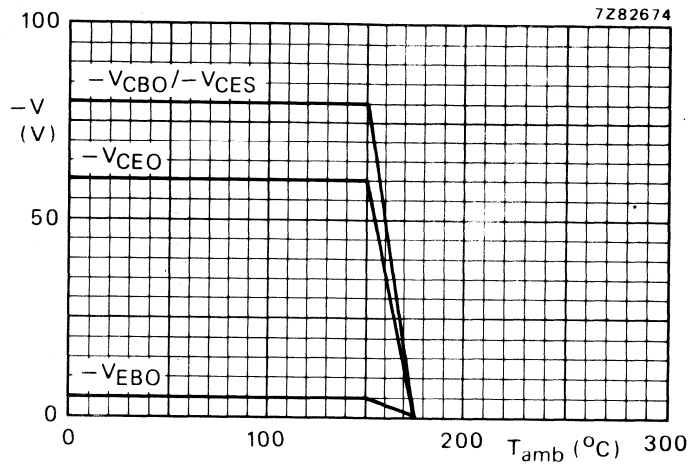

Fig. 2 Voltage derating curves.

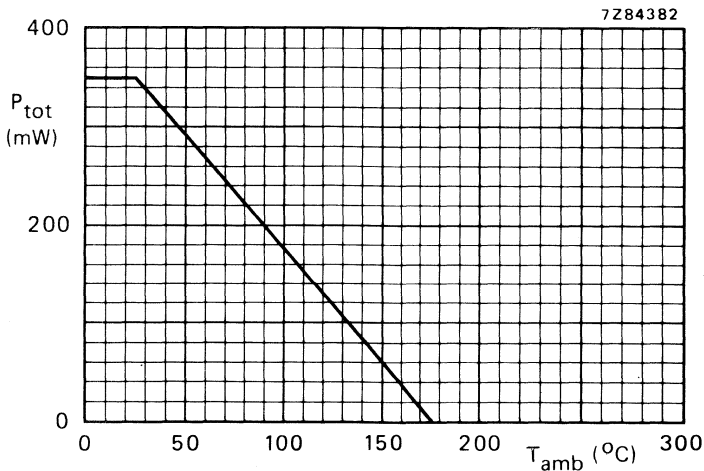

Fig. 3 Power derating curve.

SILICON PLANAR EPITAXIAL TRANSISTORS

P-N-P transistors, in a SOT-23 plastic envelope, intended for application in thick and thin-film circuits. These transistors are intended for general purposes as well as saturated switching and driver applications for industrial service.

N-P-N complements are BCX19 and BCX20 respectively.

QUICK REFERENCE DATA

		BCX17	BCX18	
Collector-emitter voltage ($V_{BE} = 0$)	$-V_{CES}$ max.	50	30	V
Collector-emitter voltage (open base)	$-V_{CEO}$ max.	45	25	V
Collector current (peak value)	$-I_{CM}$ max.	1000		mA
Total power dissipation up to $T_{amb} = 25\text{ }^{\circ}\text{C}$	P_{tot} max.	425		mW
Junction temperature	T_j max.	175		$^{\circ}\text{C}$
D.C. current gain				
$-I_C = 100\text{ mA}; -V_{CE} = 1\text{ V}$	h_{FE}	100 to 600		
Transition frequency				
$-I_C = 10\text{ mA}; -V_{CE} = 5\text{ V}; f = 35\text{ MHz}$	f_T typ.	100		MHz

MECHANICAL DATA

Fig. 1 SOT-23.

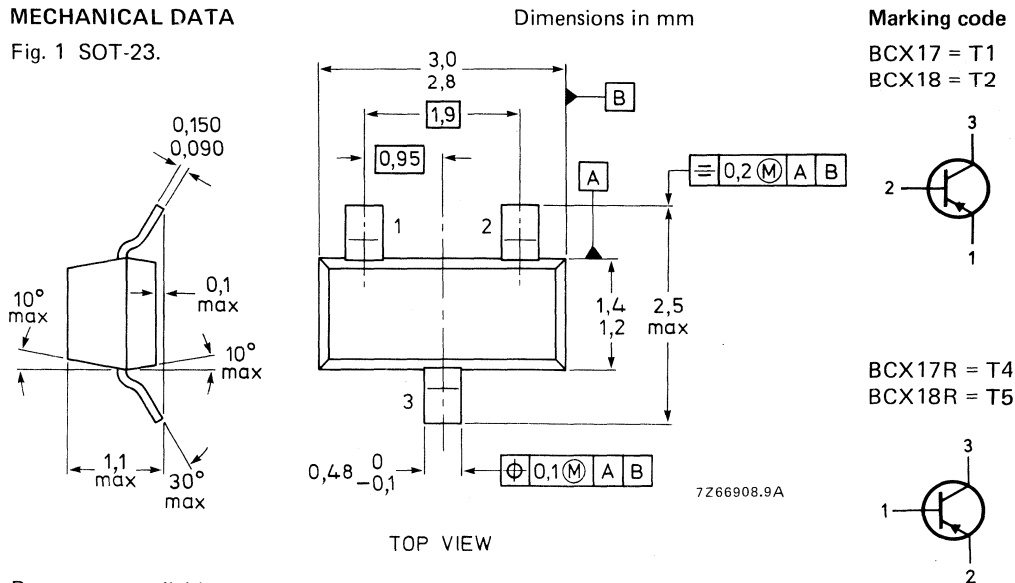

R-types are available on request

See also *Soldering recommendations*.

RATINGS

Limiting values in accordance with the Absolute Maximum System (IEC 134)

			BCX17	BCX18	
Collector-emitter voltage ($V_{BE} = 0$) (see Fig. 2)	$-V_{CES}$	max.	50	30	V
Collector-emitter voltage (open base) $-I_C = 10$ mA (see Fig. 2)	$-V_{CEO}$	max.	45	25	V
Emitter-base voltage (open collector) (see Fig. 2)	$-V_{EBO}$	max.	5	5	V
Collector current (d.c.)	$-I_C$	max.	500		mA
Collector current (peak value)	$-I_{CM}$	max.	1000		mA
Emitter current (peak value)	I_{EM}	max.	1000		mA
Base current (d.c.)	$-I_B$	max.	100		mA
Base current (peak value)	$-I_{BM}$	max.	200		mA
Total power dissipation up to $T_{amb} = 25$ °C*	P_{tot}	max.	425		mW
Storage temperature	T_{stg}		-65 to + 175		°C
Junction temperature	T_j	max.	175		°C

THERMAL CHARACTERISTICS**

$$T_j = P (R_{th j-t} + R_{th t-s} + R_{th s-a}) + T_{amb}$$

Thermal resistance

From junction to tab	$R_{th j-t}$	=	30	K/W
From tab to soldering points	$R_{th t-s}$	=	260	K/W
From soldering points to ambient*	$R_{th s-a}$	=	60	K/W

CHARACTERISTICS

$T_j = 25$ °C unless otherwise specified

Collector cut-off current $I_E = 0; -V_{CB} = 20$ V	$-I_{CBO}$	<	100	nA
$I_E = 0; -V_{CB} = 20$ V; $T_j = 150$ °C	$-I_{CBO}$	<	5	μA
Emitter cut-off current $I_C = 0; -V_{EB} = 5$ V	$-I_{EBO}$	<	10	μA
Base-emitter voltage ▲ $-I_C = 500$ mA; $-V_{CE} = 1$ V	$-V_{BE}$	<	1,2	V
Saturation voltage $-I_C = 500$ mA; $-I_B = 50$ mA	$-V_{CEsat}$	<	620	mV

* Mounted on a ceramic substrate of 15 mm x 15 mm x 0,7 mm.

** See *Thermal characteristics*.

▲ $-V_{BE}$ decreases by about 2 mV/°C with increasing temperature.

D.C. current gain

$-I_C = 100 \text{ mA}; -V_{CE} = 1 \text{ V}$

$-I_C = 300 \text{ mA}; -V_{CE} = 1 \text{ V}$

$-I_C = 500 \text{ mA}; -V_{CE} = 1 \text{ V}$

Transition frequency at $f = 35 \text{ MHz}$

$-I_C = 10 \text{ mA}; -V_{CE} = 5 \text{ V}$

Collector capacitance at $f = 1 \text{ MHz}$

$I_E = I_e = 0; -V_{CB} = 10 \text{ V}$

$h_{FE} \quad 100 \text{ to } 600$

$h_{FE} \quad > \quad 70$

$h_{FE} \quad > \quad 40$

$f_T \quad \text{typ.} \quad 100 \text{ MHz}$

$C_C \quad \text{typ.} \quad 8 \text{ pF}$

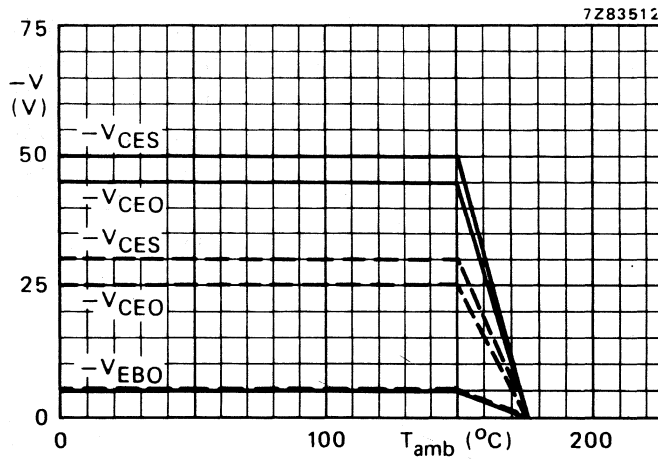

Fig. 2 Voltage derating curves. - - - BCX18 — BCX17.

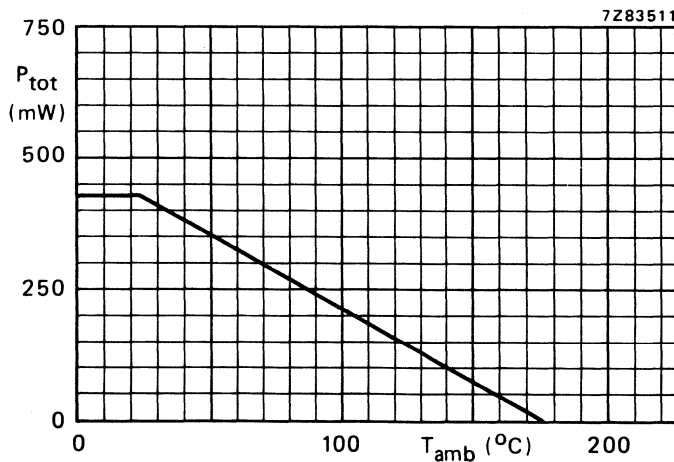

Fig. 3 Power derating curve.

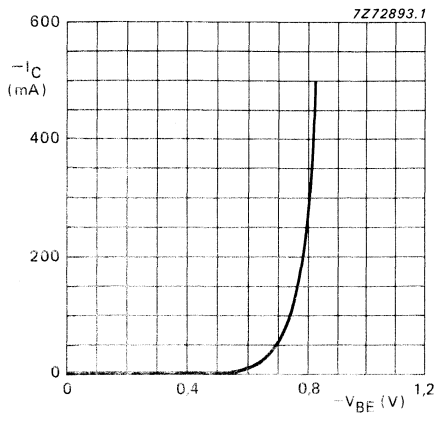

Fig. 4 $-V_{CE} = 1$ V; $T_j = 25$ °C; typical values.

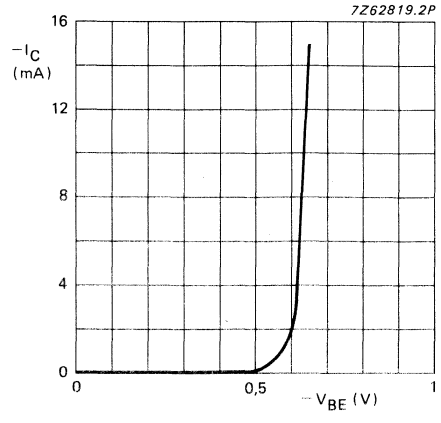

Fig. 5 $V_{CE} = 5$ V; $T_j = 25$ °C; typical values.

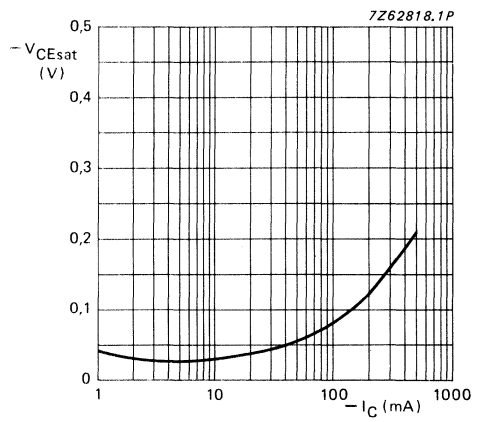

Fig. 6 $I_C/I_B = 10$; $T_j = 25$ °C; typical values.

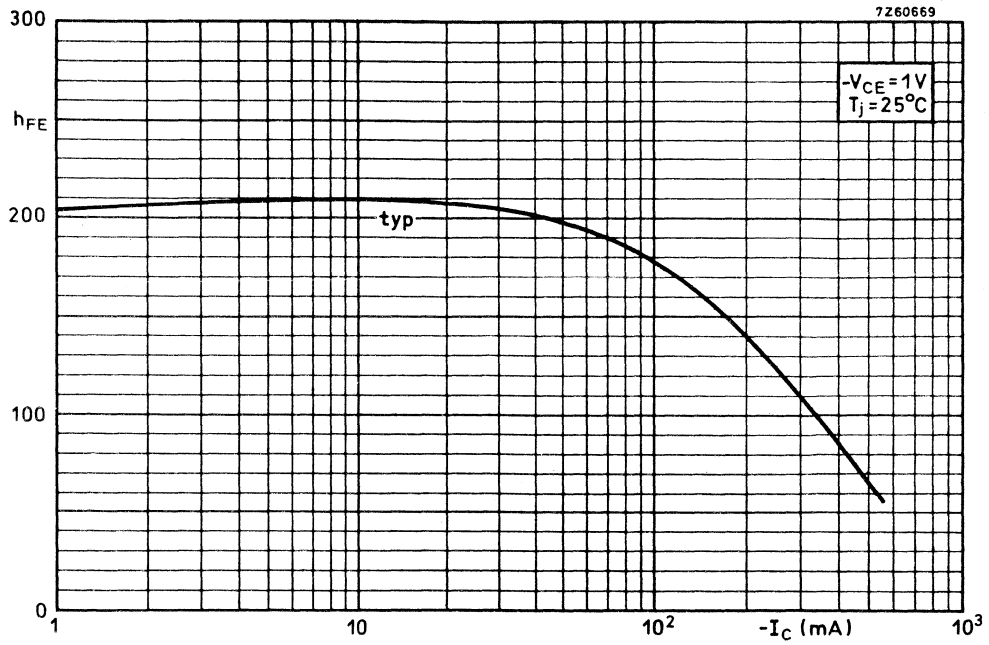

Fig. 7.

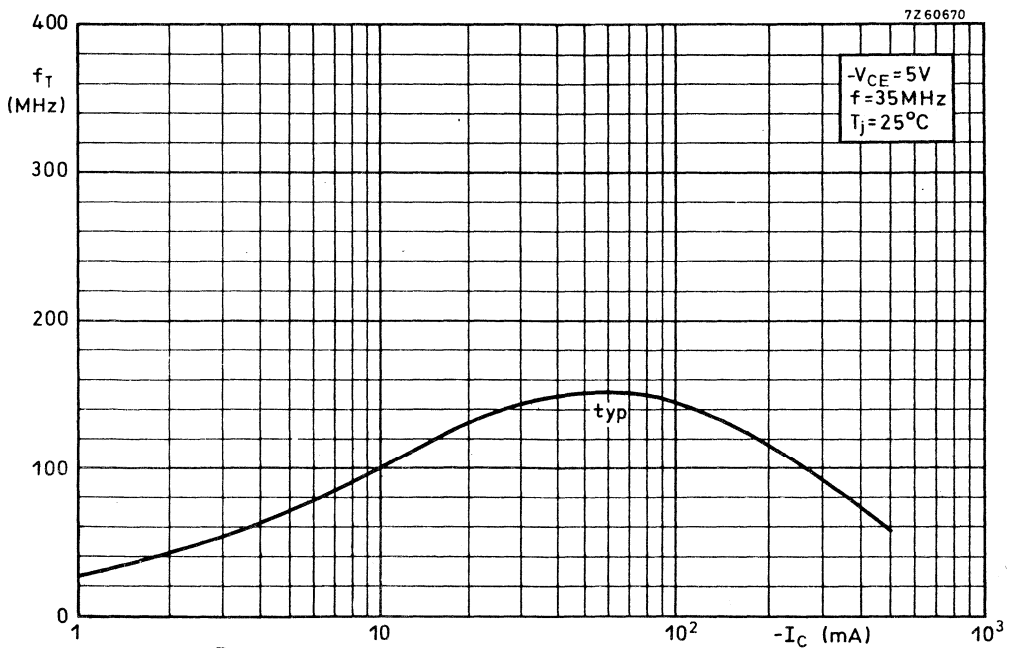

Fig. 8.

SILICON PLANAR EPITAXIAL TRANSISTORS

N-P-N transistors, in a SOT-23 plastic envelope, intended for application in thick and thin-film circuits. These transistors are intended for general purposes as well as saturated switching and driver applications for industrial service.

P-N-P complements are BCX17 and BCX18 respectively.

QUICK REFERENCE DATA

		BCX19	BCX20	
Collector-emitter voltage ($V_{BE} = 0$)	V_{CES} max.	50	30	V
Collector-emitter voltage (open base)	V_{CEO} max.	45	25	V
Collector current (peak value)	I_{CM} max.	1000		mA
Total power dissipation up to $T_{amb} = 25\text{ }^{\circ}\text{C}$	P_{tot} max.	425		mW
Junction temperature	T_j max.	175		$^{\circ}\text{C}$
D.C. current gain $I_C = 100\text{ mA}; V_{CE} = 1\text{ V}$	h_{FE}	100 to 600		
Transition frequency $I_C = 10\text{ mA}; V_{CE} = 5\text{ V}; f = 35\text{ MHz}$	f_T typ.	200		MHz

MECHANICAL DATA

Fig. 1 SOT-23.

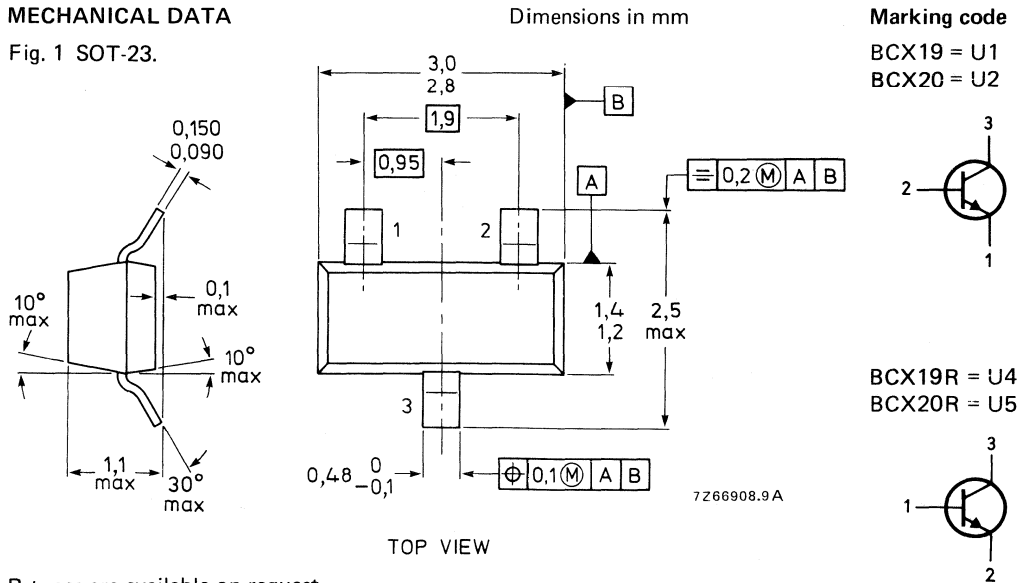

R-types are available on request.

See also *Soldering recommendations*.

RATINGS

Limiting values in accordance with the Absolute Maximum System (IEC 134)

			BCX19	BCX20	
Collector-emitter voltage ($V_{BE} = 0$) (see Fig. 2)	V_{CES}	max.	50	30	V
Collector-emitter voltage (open base) $I_C = 10$ mA (see Fig. 2)	V_{CEO}	max.	45	25	V
Emitter-base voltage (open collector) (see Fig. 2)	V_{EBO}	max.	5	5	V
Collector current (d.c.)	I_C	max.	500		mA
Collector current (peak value)	I_{CM}	max.	1000		mA
Emitter current (peak value)	$-I_{EM}$	max.	1000		mA
Base current (d.c.)	I_B	max.	100		mA
Base current (peak value)	I_{BM}	max.	200		mA
Total power dissipation up to $T_{amb} = 25$ °C*	P_{tot}	max.	425		mW
Storage temperature	T_{stg}		-65 to + 175		°C
Junction temperature	T_j	max.	175		°C

THERMAL CHARACTERISTICS**

$$T_j = P (R_{th\ j-t} + R_{th\ t-s} + R_{th\ s-a}) + T_{amb}$$

Thermal resistance

From junction to tab	$R_{th\ j-t}$	=	30	K/W
From tab to soldering points	$R_{th\ t-s}$	=	260	K/W
From soldering points to ambient*	$R_{th\ s-a}$	=	60	K/W

CHARACTERISTICS

$T_j = 25$ °C unless otherwise specified

Collector cut-off current

$$I_E = 0; V_{CB} = 20$$
 V

$$I_{CBO} < \begin{matrix} 100 \\ 5 \end{matrix} \quad \begin{matrix} \text{nA} \\ \mu\text{A} \end{matrix}$$

$$I_E = 0; V_{CB} = 20$$
 V; $T_j = 150$ °C

$$I_{CBO} < \begin{matrix} 100 \\ 5 \end{matrix} \quad \begin{matrix} \text{nA} \\ \mu\text{A} \end{matrix}$$

Emitter cut-off current

$$I_C = 0; V_{EB} = 5$$
 V

$$I_{EBO} < \begin{matrix} 10 \\ 10 \end{matrix} \quad \begin{matrix} \mu\text{A} \\ \mu\text{A} \end{matrix}$$

Base emitter voltage ▲

$$I_C = 500$$
 mA; $V_{CE} = 1$ V

$$V_{BE} < \begin{matrix} 1,2 \\ 1,2 \end{matrix} \quad \begin{matrix} \text{V} \\ \text{V} \end{matrix}$$

Saturation voltage

$$I_C = 500$$
 mA; $I_B = 50$ mA

$$V_{CEsat} < \begin{matrix} 620 \\ 620 \end{matrix} \quad \begin{matrix} \text{mV} \\ \text{mV} \end{matrix}$$

* Mounted on a ceramic substrate of 15 mm x 15 mm x 0,7 mm.

** See *Thermal characteristics*.

▲ V_{BE} decreases by about 2 mV/°C with increasing temperature.

D.C. current gain

$I_C = 100 \text{ mA}; V_{CE} = 1 \text{ V}$

$I_C = 300 \text{ mA}; V_{CE} = 1 \text{ V}$

$I_C = 500 \text{ mA}; V_{CE} = 1 \text{ V}$

Transition frequency at $f = 35 \text{ MHz}$

$I_C = 10 \text{ mA}; V_{CE} = 5 \text{ V}$

Collector capacitance at $f = 1 \text{ MHz}$

$I_E = I_e = 0; V_{CB} = 10 \text{ V}$

$h_{FE} \quad 100 \text{ to } 600$

$h_{FE} \quad > \quad 70$

$h_{FE} \quad > \quad 40$

$f_T \quad \text{typ.} \quad 200 \text{ MHz}$

$C_c \quad \text{typ.} \quad 5 \text{ pF}$

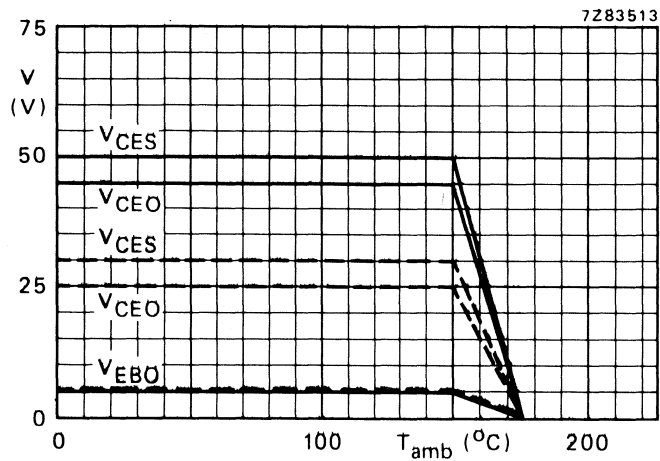

Fig. 2 Voltage derating curves. --- BCX19/BCX20 ———.

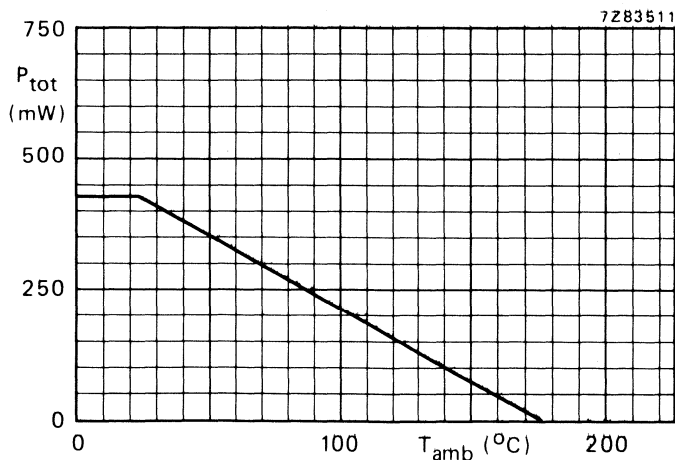

Fig. 3 Power derating curve.

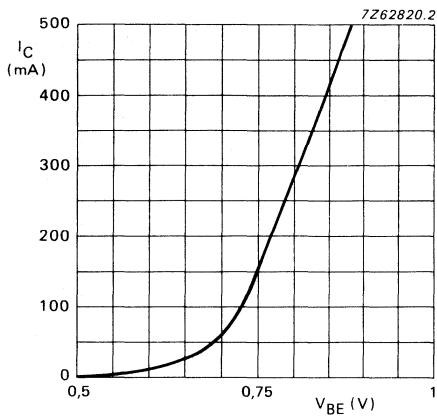

Fig. 4 $V_{CE} = 1 \text{ V}$; $T_j = 25 \text{ }^\circ\text{C}$; typical values.

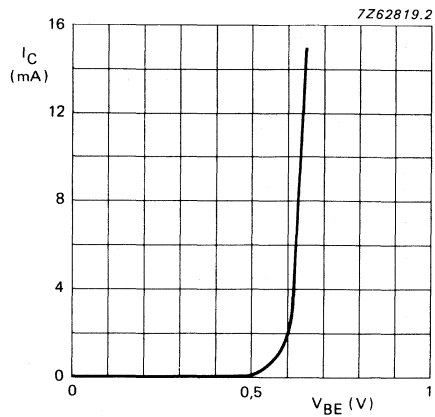

Fig. 5 $V_{CE} = 5 \text{ V}$; $T_j = 25 \text{ }^\circ\text{C}$; typical values.

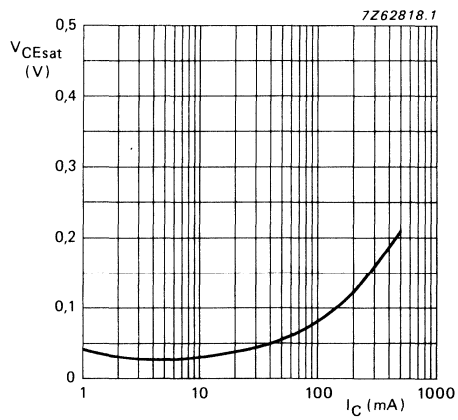

Fig. 6 $I_C/I_B = 10$; $T_j = 25 \text{ }^\circ\text{C}$; typical values.

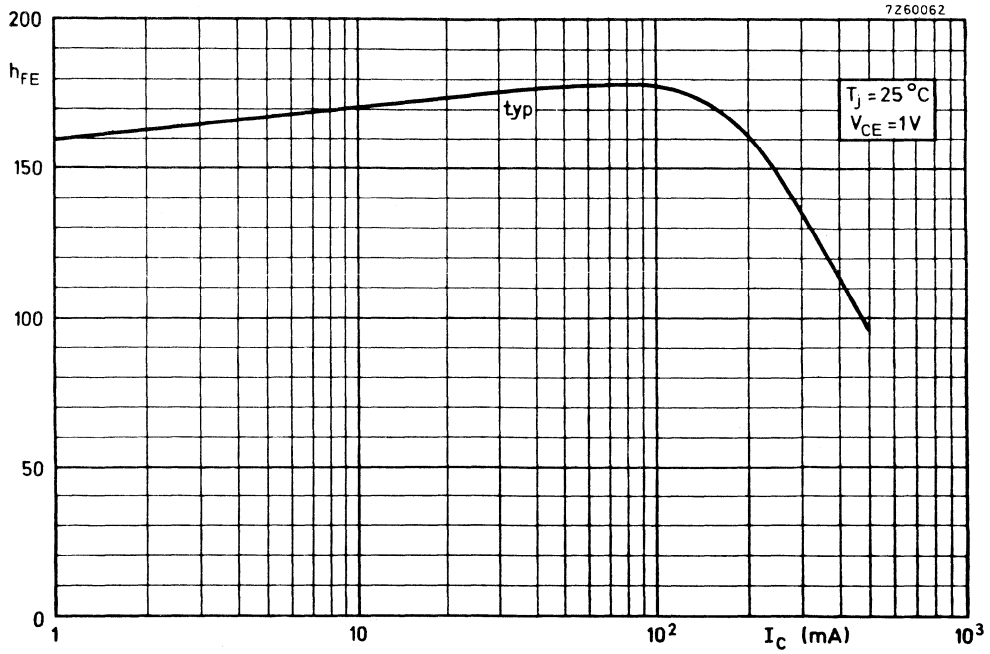

Fig. 7.

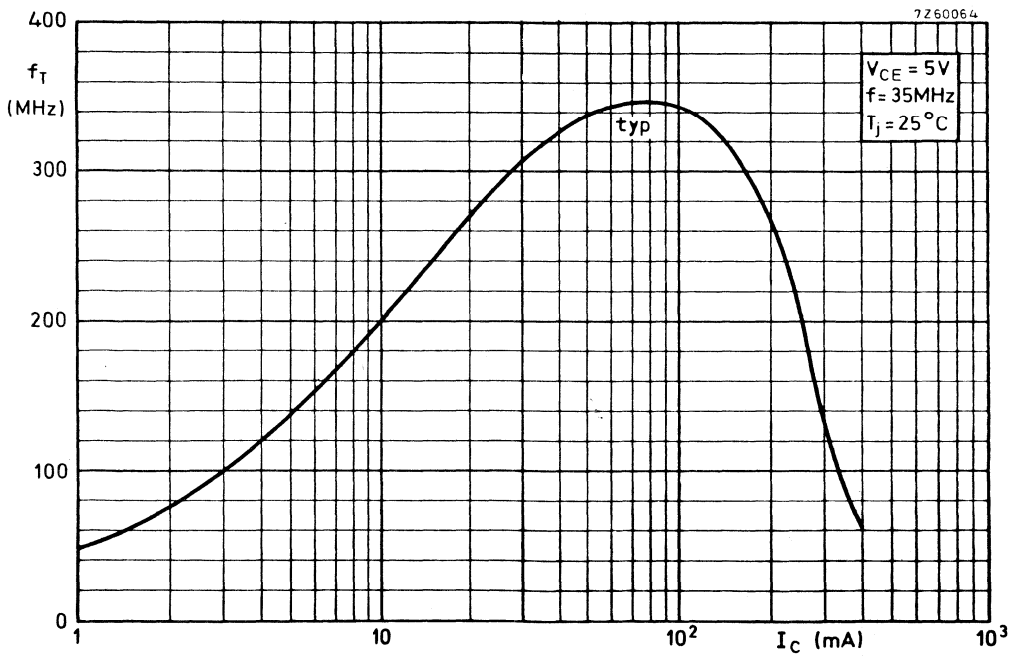

Fig. 8.

SILICON PLANAR EPITAXIAL TRANSISTORS

Medium power p-n-p transistors in a miniature plastic envelope intended for applications in thick and thin-film circuits. These transistors are intended for general purposes as well as for use in driver stages of audio amplifiers.

N-P-N complements are BCX54, BCX55 and BCX56 respectively.

QUICK REFERENCE DATA

		BCX51	BCX52	BCX53
Collector-base voltage (open emitter)	$-V_{CBO}$ max.	45	60	100 V
Collector-emitter voltage (open base)	$-V_{CEO}$ max.	45	60	80 V
Collector-emitter voltage ($R_{BE} = 1 \text{ k}\Omega$)	$-V_{CER}$ max.	45	60	100 V
Collector current (peak value)	$-I_{CM}$ max.		1,5	A
Total power dissipation up to $T_{amb} = 25 \text{ }^\circ\text{C}$	P_{tot} max.		1	W
Junction temperature	T_j max.		150	$^\circ\text{C}$
D.C. current gain	h_{FE}		40 to 250	
$-I_C = 150 \text{ mA}; -V_{CE} = 2 \text{ V}$				
Transition frequency at $f = 35 \text{ MHz}$	f_T typ.		50	MHz
$-I_C = 10 \text{ mA}; -V_{CE} = 5 \text{ V}$				

MECHANICAL DATA

Fig. 1 SOT-89.

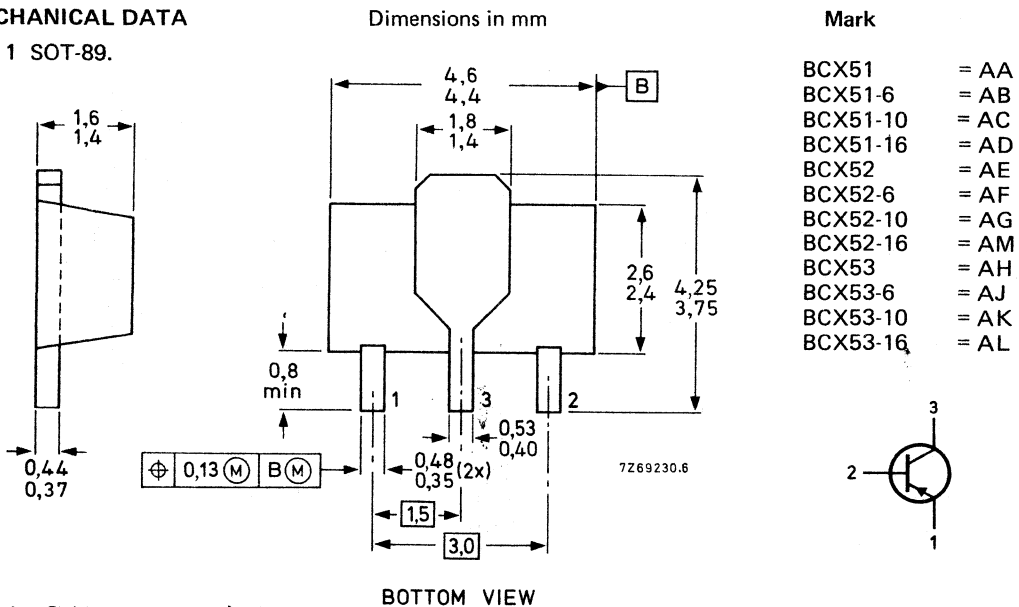

See also *Soldering recommendations*.

RATINGS

Limiting values in accordance with the Absolute Maximum System (IEC 134)

			BCX51	BCX52	BCX53
Collector-base voltage (open emitter)	$-V_{CBO}$	max.	45	60	100 V
Collector-emitter voltage (open base)	$-V_{CEO}$	max.	45	60	80 V
Collector-emitter voltage ($R_{BE} = 1 \text{ k}\Omega$)	$-V_{CER}$	max.	45	60	100 V
Emitter-base voltage (open collector)	$-V_{EBO}$	max.	5	5	5 V
Collector current (d.c.)	$-I_C$	max.		1,0	A
Collector current (peak value)	$-I_{CM}$	max.		1,5	A
Base current (d.c.)	$-I_B$	max.		0,1	A
Base current (peak value)	$-I_{BM}$	max.		0,2	A
Total power dissipation up to $T_{amb} = 25 \text{ }^\circ\text{C}$ mounted on a ceramic substrate area = $2,5 \text{ cm}^2$; thickness = $0,7 \text{ mm}$	P_{tot}	max.		1,0	W
Storage temperature	T_{stg}			-65 to +150	$^\circ\text{C}$
Junction temperature	T_j	max.		150	$^\circ\text{C}$

THERMAL RESISTANCE

From junction to collector tab	$R_{th \text{ j-tab}}$	=		10	K/W
From junction to ambient in free air mounted on a ceramic substrate area = $2,5 \text{ cm}^2$; thickness = $0,7 \text{ mm}$	$R_{th \text{ j-a}}$	=		125	K/W

CHARACTERISTICS

$T_{amb} = 25 \text{ }^\circ\text{C}$ unless otherwise specified

Collector cut-off current

$I_E = 0; -V_{CB} = 30 \text{ V}$

$-I_{CBO} < 100 \text{ nA}$

$I_E = 0; -V_{CB} = 30 \text{ V}; T_j = 125 \text{ }^\circ\text{C}$

$-I_{CBO} < 10 \text{ } \mu\text{A}$

Emitter cut-off current

$I_C = 0; -V_{EB} = 5 \text{ V}$

$-I_{EBO} < 10 \text{ } \mu\text{A}$

Base-emitter voltage

$-I_C = 500 \text{ mA}; -V_{CE} = 2 \text{ V}$

$-V_{BE} < 1 \text{ V}$

Saturation voltage

$-I_C = 500 \text{ mA}; -I_B = 50 \text{ mA}$

$-V_{CEsat} < 0,5 \text{ V}$

D.C. current gain

$-I_C = 5 \text{ mA}; -V_{CE} = 2 \text{ V}$

$h_{FE} > 25$

$-I_C = 150 \text{ mA}; -V_{CE} = 2 \text{ V}$

$h_{FE} > 40 \text{ to } 250$

$-I_C = 500 \text{ mA}; -V_{CE} = 2 \text{ V}$

$h_{FE} > 25$

Transition frequency at $f = 35 \text{ MHz}$

$-I_C = 10 \text{ mA}; -V_{CE} = 5 \text{ V}$

$f_T \text{ typ. } 50 \text{ MHz}$

CHARACTERISTICS (continued)

D.C. current gain

$-I_C = 150 \text{ mA}; -V_{CE} = 2 \text{ V}$

	BCX51-6	BCX51-10	BCX51-16
	52-6	52-10	52-16
	53-6	53-10	53-16
$h_{FE} >$	40	63	100
$h_{FE} <$	100	160	250

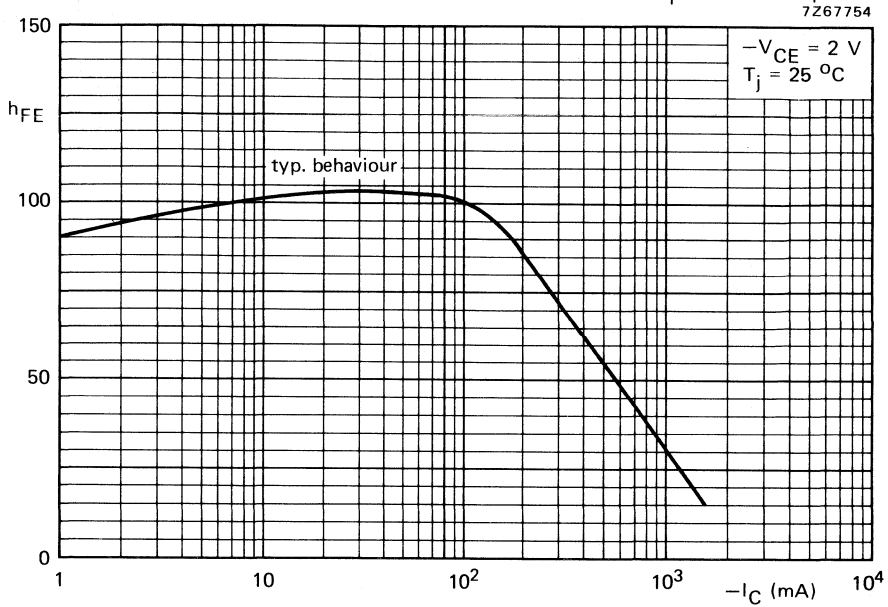

Fig. 2.

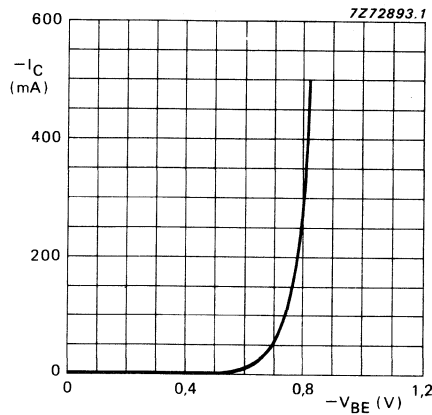

Fig. 3 $-V_{CE} = 2 \text{ V}; T_j = 25 \text{ }^\circ\text{C};$ typical values.

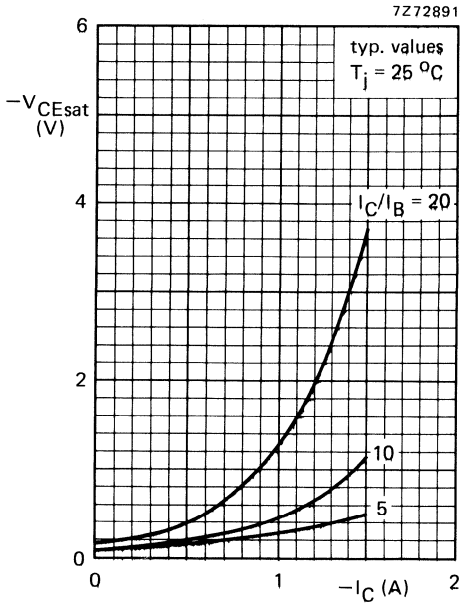

Fig. 4.

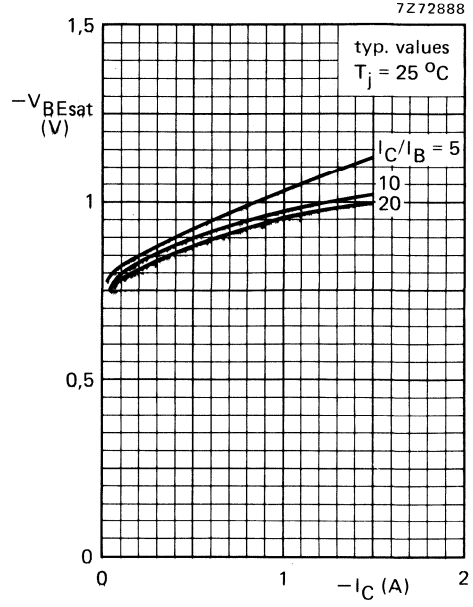

Fig. 5.

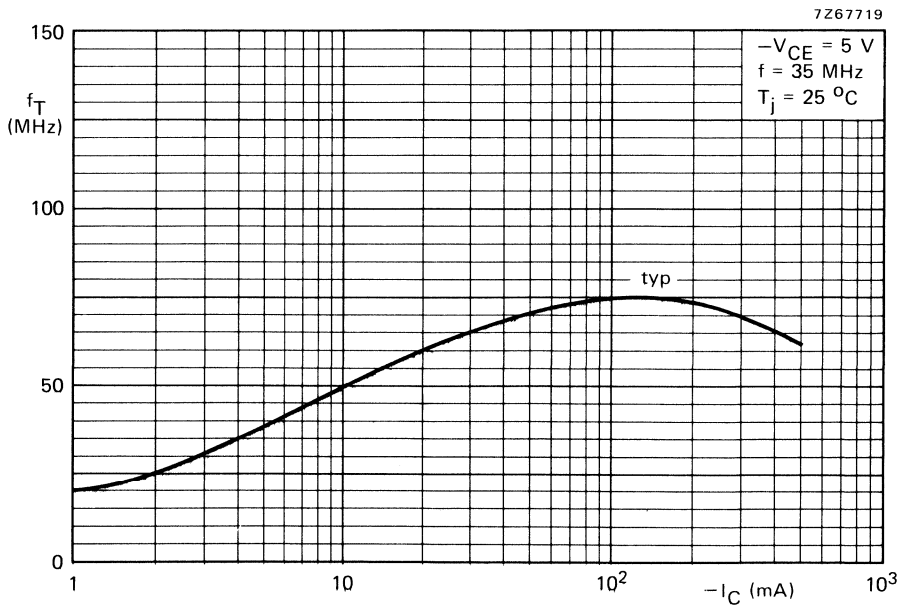

Fig. 6.

SILICON PLANAR EPITAXIAL TRANSISTORS

Medium power n-p-n transistors in a miniature plastic envelope intended for applications in thick and thin-film circuits. These transistors are intended for general purposes as well as for use in driver stages of audio amplifiers.

P-N-P complements are BCX51, BCX52 and BCX53 respectively.

QUICK REFERENCE DATA

		BCX54	BCX55	BCX56
Collector-base voltage (open emitter)	V_{CBO} max.	45	60	100 V
Collector-emitter voltage (open base)	V_{CEO} max.	45	60	80 V
Collector-emitter voltage ($R_{BE} = 1 \text{ k}\Omega$)	V_{CER} max.	45	60	100 V
Collector current (peak value)	I_{CM} max.		1,5	A
Total power dissipation up to $T_{amb} = 25 \text{ }^\circ\text{C}$	P_{tot} max.		1	W
Junction temperature	T_j max.		150	$^\circ\text{C}$
D.C. current gain $I_C = 150 \text{ mA}; V_{CE} = 2 \text{ V}$	h_{FE}		40 to 250	
Transition frequency at $f = 35 \text{ MHz}$ $I_C = 10 \text{ mA}; V_{CE} = 5 \text{ V}$	f_T typ.		130	MHz

MECHANICAL DATA

Fig. 1 SOT-89.

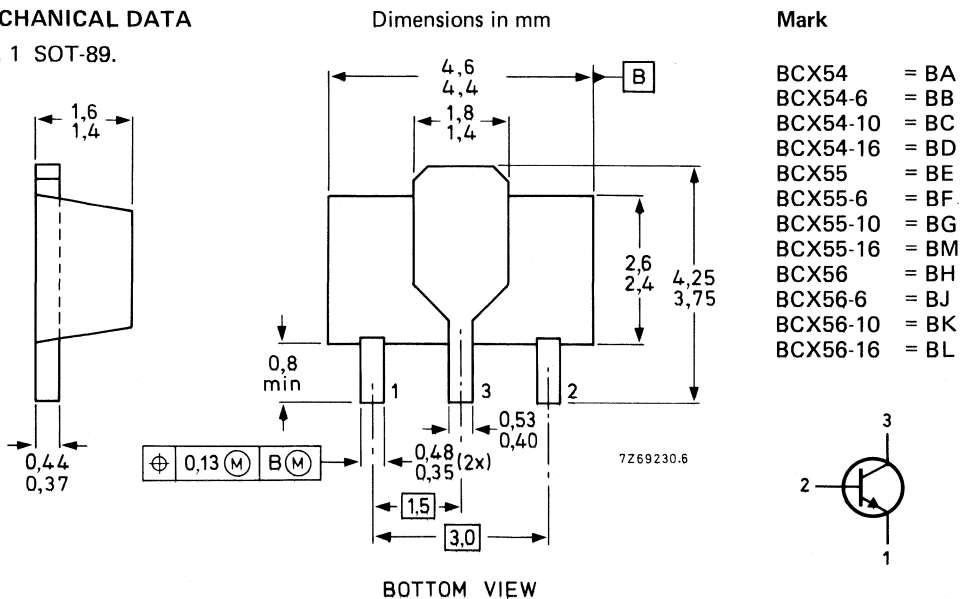

See also *Soldering recommendations*.

RATINGS

Limiting values in accordance with the Absolute Maximum System (IEC 134)

			BCX54	BCX55	BCX56
Collector-base voltage (open emitter)	V_{CBO}	max.	45	60	100 V
Collector-emitter voltage (open base)	V_{CEO}	max.	45	60	80 V
Collector-emitter voltage ($R_{BE} = 1 \text{ k}\Omega$)	V_{CER}	max.	45	60	100 V
Emitter-base voltage (open collector)	V_{EBO}	max.	5	5	5 V
Collector current (d.c.)	I_C	max.	1,0		A
Collector current (peak value)	I_{CM}	max.	1,5		A
Base current (d.c.)	I_B	max.	0,1		A
Base current (peak value)	I_{BM}	max.	0,2		A
Total power dissipation up to $T_{amb} = 25 \text{ }^\circ\text{C}$ mounted on a ceramic substrate area = 2,5 cm ² ; thickness = 0,7 mm	P_{tot}	max.	1,0		W
Storage temperature	T_{stg}		-65 to +150		$^\circ\text{C}$
Junction temperature	T_j	max.	150		$^\circ\text{C}$

THERMAL RESISTANCE

From junction to collector tab	$R_{th \text{ j-tab}}$	=	10		K/W
From junction to ambient in free air mounted on a ceramic substrate area = 2,5 cm ² ; thickness = 0,7 mm	$R_{th \text{ j-a}}$	=	125		K/W

CHARACTERISTICS

$T_{amb} = 25 \text{ }^\circ\text{C}$ unless otherwise specified

Collector cut-off current $I_E = 0; V_{CB} = 30 \text{ V}$	I_{CBO}	<	100		nA
$I_E = 0; V_{CB} = 30 \text{ V}; T_j = 125 \text{ }^\circ\text{C}$	I_{CBO}	<	10		μA
Emitter cut-off current $I_C = 0; V_{EB} = 5 \text{ V}$	I_{EBO}	<	10		μA
Base-emitter voltage $I_C = 500 \text{ mA}; V_{CE} = 2 \text{ V}$	V_{BE}	<	1		V
Saturation voltage $I_C = 500 \text{ mA}; I_B = 50 \text{ mA}$	V_{CEsat}	<	0,5		V
D.C. current gain $I_C = 5 \text{ mA}; V_{CE} = 2 \text{ V}$	h_{FE}	>	25		
$I_C = 150 \text{ mA}; V_{CE} = 2 \text{ V}$	h_{FE}		40 to 250		
$I_C = 500 \text{ mA}; V_{CE} = 2 \text{ V}$	h_{FE}	>	25		
Transition frequency at $f = 35 \text{ MHz}$ $I_C = 10 \text{ mA}; V_{CE} = 5 \text{ V}$	f_T	typ.	130		MHz

CHARACTERISTICS (continued)

D.C. current gain
 $I_C = 150 \text{ mA}; V_{CE} = 2 \text{ V}$

	BXC54-6 55-6 56-6	BCX54-10 55-10 56-10	BCX54-16 55-16 56-16
$h_{FE} >$	40	63	100
$h_{FE} <$	100	160	250

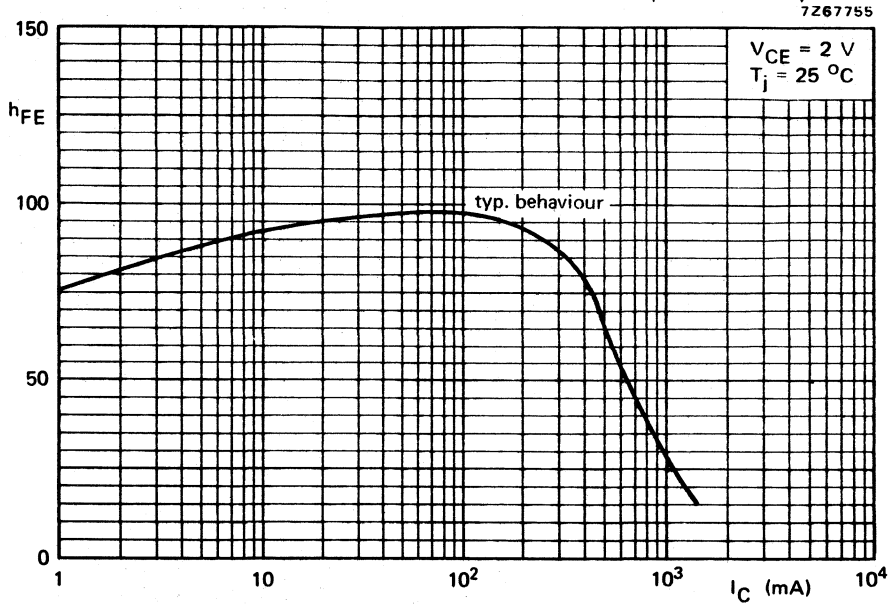

Fig. 2.

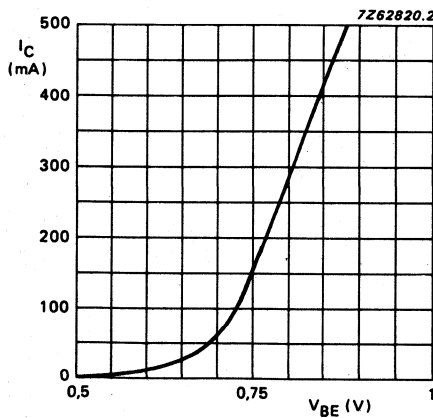

Fig. 3 $V_{CE} = 2 \text{ V}; T_j = 25 \text{ }^\circ\text{C};$ typical values.

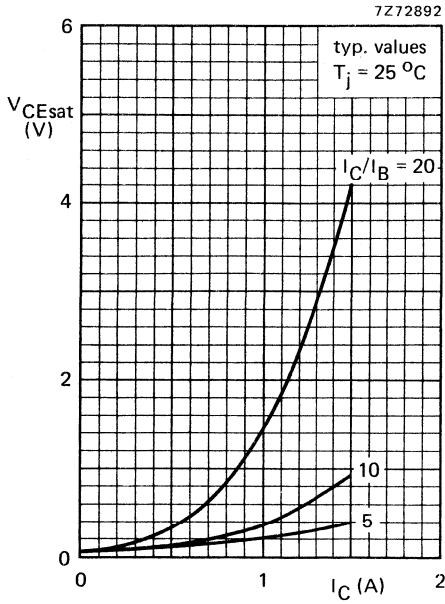

Fig. 4.

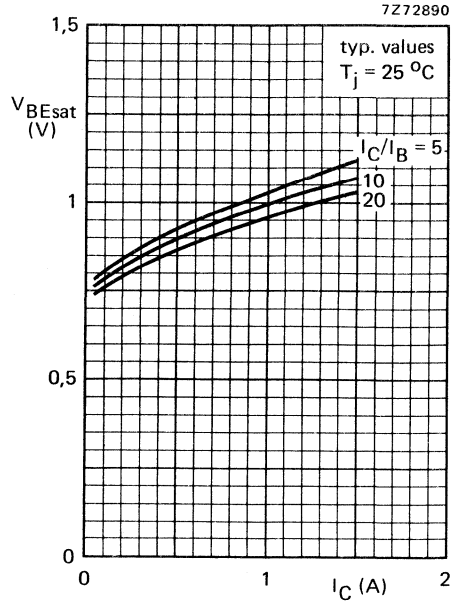

Fig. 5.

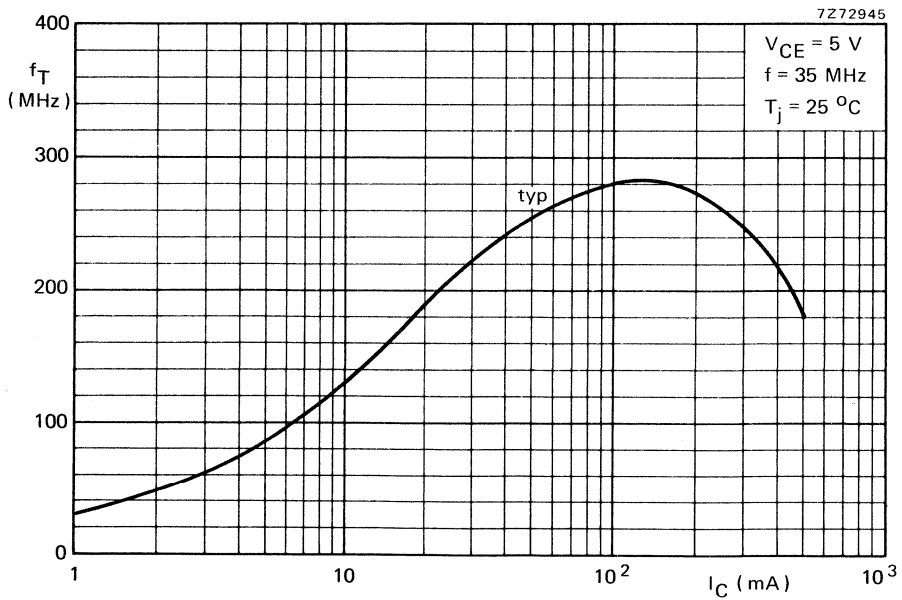

Fig. 6.

SILICON PLANAR EPITAXIAL TRANSISTORS

N-P-N silicon transistors, in a microminiature plastic envelope, intended for low level, low noise, low frequency purpose applications in hybrid circuits.

QUICK REFERENCE DATA

Collector-emitter voltage ($V_{BE} = 0$)	V_{CES}	max.	45 V
Collector-emitter voltage (open base)	V_{CEO}	max.	45 V
Collector current (d.c.)	I_C	max.	200 mA
Total power dissipation	P_{tot}	max.	150 mW
Junction temperature	T_j	max.	150 °C
Transition frequency at $f = 100$ MHz $V_{CE} = 5$ V; $I_C = 10$ mA	f_T	typ.	250 MHz
Noise figure at $f = 1$ kHz $V_{CE} = 5$ V; $I_C = 200 \mu\text{A}$; $B = 200$ Hz	F	typ.	2 dB

MECHANICAL DATA

Fig. 1 SOT-23.

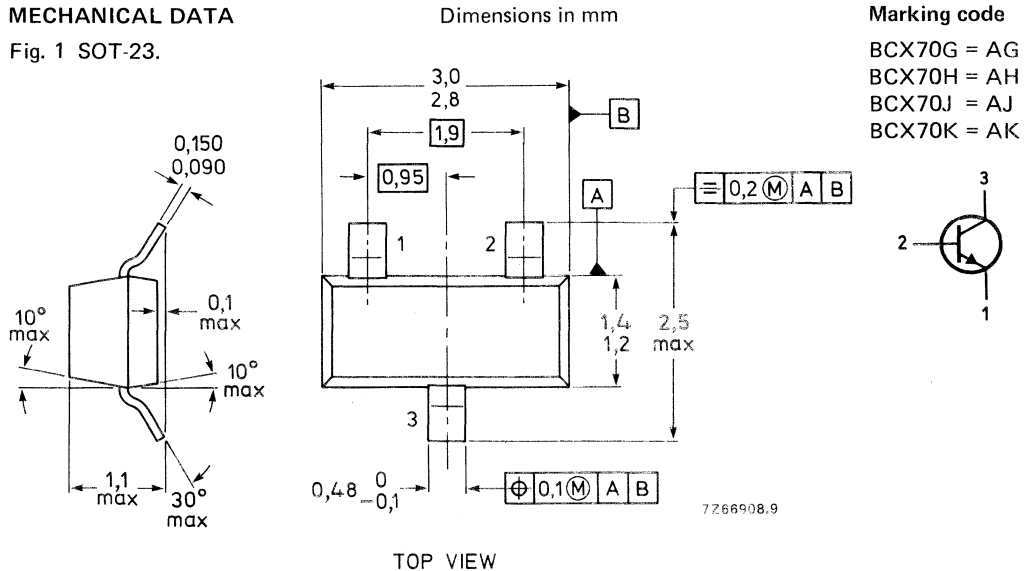

See also *Soldering recommendations*.

RATINGS

Limiting values in accordance with the Absolute Maximum System (IEC 134)

Collector-emitter voltage ($V_{BE} = 0$)	V_{CES}	max.	45 V
Collector-emitter voltage (open base)	V_{CEO}	max.	45 V
Emitter-base voltage (open collector)	V_{EBO}	max.	5 V
Collector current (d.c.)	I_C	max.	200 mA
Base current	I_B	max.	50 mA
Total power dissipation up to $T_{amb} = 100\text{ }^\circ\text{C}^{**}$	P_{tot}	max.	150 mW
Storage temperature	T_{stg}		-55 to + 125 $^\circ\text{C}$
Junction temperature	T_j	max.	150 $^\circ\text{C}$

THERMAL CHARACTERISTICS*

$$T_j = P_x (R_{th\ j-t} + R_{th\ t-s} + R_{th\ s-a}) + T_{amb}$$

Thermal resistance

From junction to tab	$R_{th\ j-t}$	=	50 K/W
From tab to soldering points	$R_{th\ t-s}$	=	280 K/W
From soldering points to ambient**	$R_{th\ s-a}$	=	90 K/W

CHARACTERISTICS

$T_{amb} = 25\text{ }^\circ\text{C}$ unless otherwise specified

Collector-emitter cut-off current

$$V_{BE} = 0; V_{CE} = 45\text{ V}$$

$$I_{CES} < 20\text{ nA}$$

$$V_{BE} = 0; V_{CE} = 45\text{ V}; T_{amb} = 150\text{ }^\circ\text{C}$$

$$I_{CES} < 20\text{ }\mu\text{A}$$

Emitter-base cut-off current

$$I_C = 0; V_{EB} = 4\text{ V}$$

$$I_{EBO} < 20\text{ nA}$$

Saturation voltages

$$\text{at } I_C = 10\text{ mA}; I_B = 0,25\text{ mA}$$

$$V_{CEsat} = 0,05\text{ to }0,35\text{ V}$$

$$V_{BEsat} = 0,6\text{ to }0,85\text{ V}$$

$$\text{at } I_C = 50\text{ mA}; I_B = 1,25\text{ mA}$$

$$V_{CEsat} = 0,1\text{ to }0,55\text{ V}$$

$$V_{BEsat} = 0,7\text{ to }1,05\text{ V}$$

Transition frequency at $f = 100\text{ MHz}$ ▲

$$I_C = 10\text{ mA}; V_{CE} = 5\text{ V}$$

$$f_T > 125\text{ MHz}$$

typ. 250 MHz

Collector capacitance at $f = 1\text{ MHz}$

$$I_E = I_e = 0; V_{CB} = 10\text{ V}$$

$$C_c \text{ typ. } 2,5\text{ pF}$$

Emitter capacitance at $f = 1\text{ MHz}$

$$I_C = I_c = 0; V_{EB} = 0,5\text{ V}$$

$$C_e \text{ typ. } 8\text{ pF}$$

Noise figure at $R_S = 2\text{ k}\Omega$

$$I_C = 200\text{ }\mu\text{A}; V_{CE} = 5\text{ V}; f = 1\text{ kHz}; B = 200\text{ Hz}$$

$$F \text{ typ. } 2\text{ dB}$$

< 6 dB

* See *Thermal characteristics*.

** Mounted on a ceramic substrate of 8 mm x 10 mm x 0,7 mm.

▲ Measured under pulse conditions.

		G	H	J	K	
D.C. current gain						
$V_{CE} = 5 \text{ V}; I_C = 10 \mu\text{A}$	h_{FE} typ.	78	145	220	300	
	>	—	20	40	100	
$V_{CE} = 5 \text{ V}; I_C = 2 \text{ mA}$	>	120	180	250	380	
	h_{FE} typ.	170	250	350	500	
$V_{CE} = 1 \text{ V}; I_C = 50 \text{ mA}$	<	220	310	460	630	
	h_{FE} >	50	70	90	100	
Input impedance						
$V_{CE} = 5 \text{ V}; I_C = 2 \text{ mA}; f = 1 \text{ kHz}$	h_{ie} typ.	2,7	3,6	4,5	7,5 k Ω	←
Reverse voltage transfer ratio						
$V_{CE} = 5 \text{ V}; I_C = 2 \text{ mA}; f = 1 \text{ kHz}$	h_{re} typ.	1,5	2	2	3 10^{-4}	
Small-signal current gain						
$V_{CE} = 5 \text{ V}; I_C = 2 \text{ mA}; f = 1 \text{ kHz}$	h_{fe} typ.	200	260	330	520	←
Output admittance						
$V_{CE} = 5 \text{ V}; I_C = 2 \text{ mA}; f = 1 \text{ kHz}$	h_{oe} typ.	18	24	30	50 μS	←
Base-emitter voltage						
$V_{CE} = 5 \text{ V}; I_C = 2 \text{ mA}$	V_{BE} typ.	0,55 to 0,75			V	
			0,65		V	
$V_{CE} = 5 \text{ V}; I_C = 10 \mu\text{A}$	V_{BE} typ.		0,52		V	
$V_{CE} = 1 \text{ V}; I_C = 50 \text{ mA}$	V_{BE} typ.		0,78		V	

Switching times

$I_{Con} = 10 \text{ mA}$; $I_{Bon} = -I_{Boff} = 1 \text{ mA}$
 $V_{CC} = 10 \text{ V}$; $R_L = 990 \Omega$

turn-on time ($t_d + t_r$)

t_{on} typ. 85 ns
 < 150 ns

turn-off time ($t_s + t_f$)

t_{off} typ. 480 ns
 < 800 ns

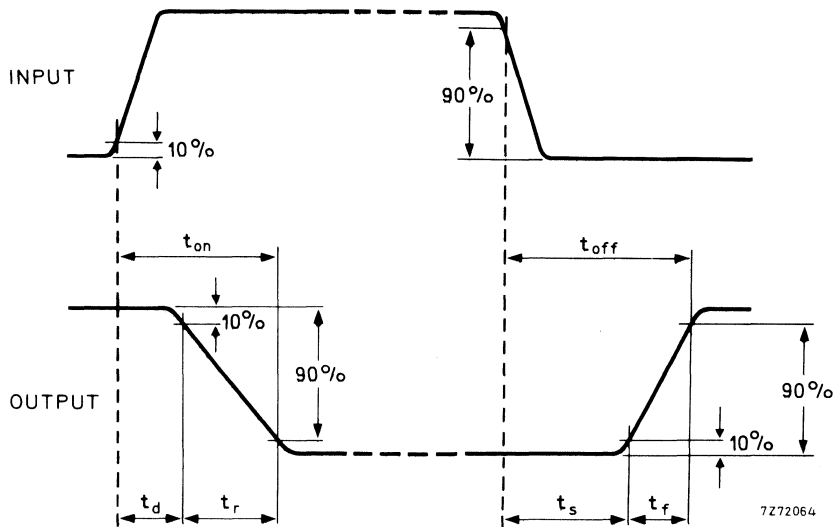

Fig. 2 Switching waveforms.

SILICON PLANAR EPITAXIAL TRANSISTORS

P-N-P silicon transistors, in a microminiature plastic envelope, intended for low level, low noise, low frequency purpose applications in hybrid circuits.

QUICK REFERENCE DATA

Collector-emitter voltage ($V_{BE} = 0$)	$-V_{CES}$	max.	45 V
Collector-emitter voltage (open base)	$-V_{CEO}$	max.	45 V
Collector current (d.c.)	$-I_C$	max.	200 mA
Total power dissipation	P_{tot}	max.	150 mW
Junction temperature	T_j	max.	150 °C
Transition frequency at $f = 100$ MHz $-V_{CE} = 5$ V; $-I_C = 10$ mA	f_T	typ.	180 MHz
Noise figure at $f = 1$ kHz $-V_{CE} = 5$ V; $-I_C = 200$ μ A	F	typ.	2 dB

MECHANICAL DATA

Fig. 1 SOT-23.

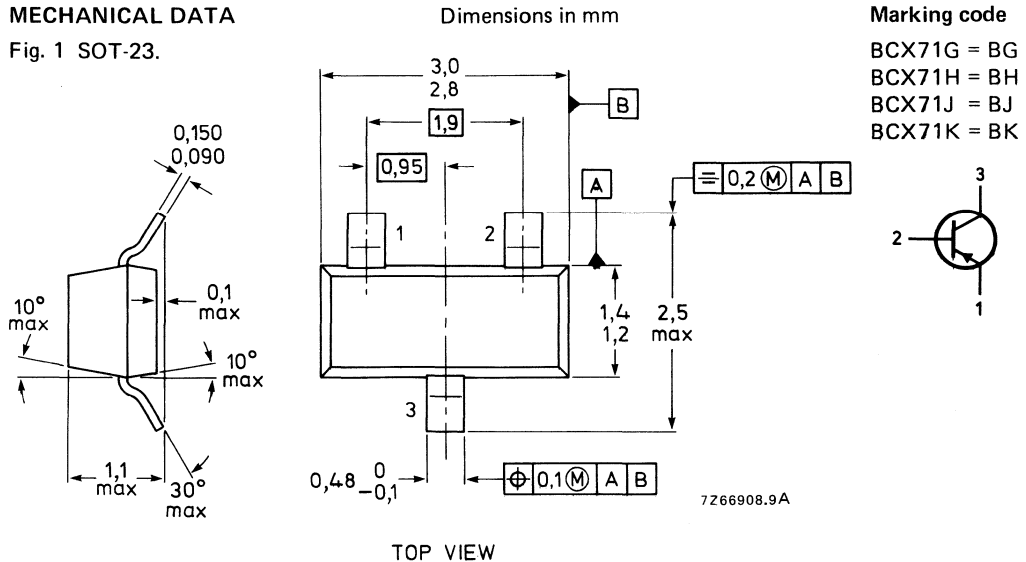

See also *Soldering recommendations.*

RATINGS

Limiting values in accordance with the Absolute Maximum System (IEC 134)

Collector-emitter voltage ($V_{BE} = 0$)	$-V_{CES}$	max.	45 V
Collector-emitter voltage (open base)	$-V_{CEO}$	max.	45 V
Emitter-base voltage (open collector)	$-V_{EBO}$	max.	5 V
Collector current (d.c.)	$-I_C$	max.	200 mA
Base current	$-I_B$	max.	50 mA
Total power dissipation up to $T_{amb} = 100\text{ }^\circ\text{C}^{**}$	P_{tot}	max.	150 mW
Storage temperature	T_{stg}		-55 to $+125\text{ }^\circ\text{C}$
Junction temperature	T_j	max.	$150\text{ }^\circ\text{C}$

THERMAL CHARACTERISTICS*

$$T_j = P_x (R_{th\ j-t} + R_{th\ t-s} + R_{th\ s-a}) + T_{amb}$$

Thermal resistance

From junction to tab	$R_{th\ j-t}$	=	50 K/W
From tab to soldering points	$R_{th\ t-s}$	=	280 K/W
From soldering points to ambient**	$R_{th\ s-a}$	=	90 K/W

CHARACTERISTICS

$T_{amb} = 25\text{ }^\circ\text{C}$ unless otherwise specified

Collector-emitter cut-off current

$$V_{EB} = 0; -V_{CE} = 45\text{ V}$$

$$-I_{CES} < 20\text{ nA}$$

$$V_{EB} = 0; -V_{CE} = 45\text{ V}; T_{amb} = 150\text{ }^\circ\text{C}$$

$$-I_{CES} < 20\text{ }\mu\text{A}$$

Emitter-base cut-off current

$$I_C = 0; -V_{EB} = 4\text{ V}$$

$$-I_{EBO} < 20\text{ nA}$$

Saturation voltages

$$-I_C = 10\text{ mA}; -I_B = 0,25\text{ mA}$$

$$-V_{CEsat} \quad 0,06\text{ to }0,25\text{ V}$$

$$-V_{BEsat} \quad 0,6\text{ to }0,85\text{ V}$$

$$-I_C = 50\text{ mA}; -I_B = 1,25\text{ mA}$$

$$-V_{CEsat} \quad 0,12\text{ to }0,55\text{ V}$$

$$-V_{BEsat} \quad 0,68\text{ to }1,05\text{ V}$$

Transition frequency at $f = 100\text{ MHz}$ ▲

$$-V_{CE} = 5\text{ V}; -I_C = 10\text{ mA}$$

$$f_T \quad \text{typ.} \quad 180\text{ MHz}$$

Collector capacitance at $f = 1\text{ MHz}$

$$-V_{CB} = 10\text{ V}; I_E = I_e = 0$$

$$C_C \quad \text{typ.} \quad 4,5\text{ pF}$$

Emitter capacitance at $f = 1\text{ MHz}$

$$-V_{EB} = 0,5\text{ V}; I_C = I_c = 0$$

$$C_e \quad \text{typ.} \quad 11\text{ pF}$$

Noise figure at $R_S = 2\text{ k}\Omega$

$$-V_{CE} = 5\text{ V}; -I_C = 200\text{ }\mu\text{A}; B = 200\text{ Hz}$$

$$F \quad \text{typ.} \quad 2\text{ dB}$$

$$< \quad 6\text{ dB}$$

* See *Thermal characteristics*.

** Mounted on a ceramic substrate of 8 mm x 10 mm x 0,7 mm.

▲ Measured under pulse conditions.

		G	H	J	K
D.C. current gain -V _{CE} = 5 V; -I _C = 10 μA	h _{FE} typ.	140	200	270	340
	>	-	30	40	100
	>	120	180	250	380
-V _{CE} = 5 V; -I _C = 2 mA	h _{FE} typ.	170	250	350	500
	<	220	310	460	630
-V _{CE} = 1 V; -I _C = 50 mA	h _{FE} >	60	80	100	110
Input impedance -V _{CE} = 5 V; -I _C = 2 mA; f = 1 kHz	h _{ie} typ.	2,7	3,6	4,5	7,5 kΩ
Reverse voltage transfer ratio -V _{CE} = 5 V; -I _C = 2 mA; f = 1 kHz	h _{re} typ.	1,5	2	2	3 · 10 ⁻⁴
Small-signal current gain -V _{CE} = 5 V; -I _C = 2 mA; f = 1 kHz	h _{fe} typ.	200	260	330	520
Output admittance -V _{CE} = 5 V; -I _C = 2 mA; f = 1 kHz	h _{oe} typ.	18	24	30	50 μS ←
Base-emitter voltage -V _{CE} = 5 V; -I _C = 2 mA	V _{BE} typ.	0,6 to 0,75			V
-V _{CE} = 5 V; -I _C = 10 μA	V _{BE} typ.	0,65			V
-V _{CE} = 5 V; -I _C = 10 μA	V _{BE} typ.	0,55			V
-V _{CE} = 1 V; -I _C = 50 mA	V _{BE} typ.	0,72			V

Switching times

$-I_{Con} = 10 \text{ mA}; -I_{Bon} = I_{Boff} = 1 \text{ mA}$
 $-V_{CC} = 10 \text{ V}; R_L = 990 \Omega$

turn-on time ($t_d + t_r$)

t_{on} typ. 85 ns
 < 150 ns

turn-off time ($t_s + t_f$)

t_{off} typ. 480 ns
 < 800 ns

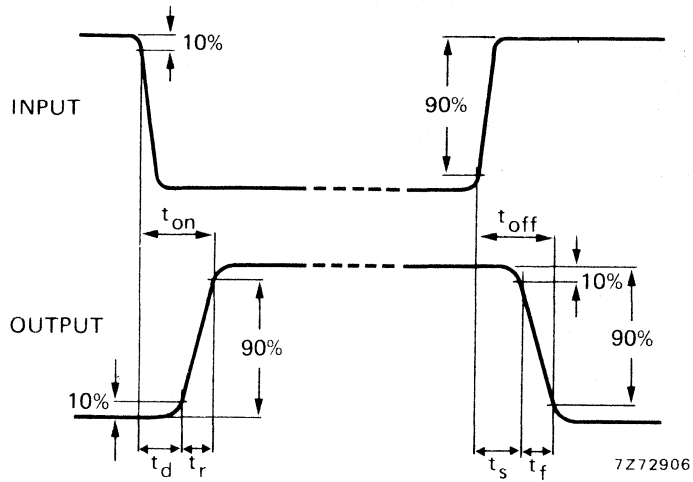

Fig. 2 Switching waveforms.

N-CHANNEL SILICON FIELD-EFFECT TRANSISTORS

Asymmetrical N-channel planar epitaxial junction field-effect transistors in the miniature plastic envelope intended for applications up to the v.h.f. range in hybrid thick and thin-film circuits. Special features are the low feedback capacitance and the low noise figure. These features make the product very suitable for applications such as the r.f. stages in f.m. portables (BF510), car radios (BF511) and mains radios (BF512) or the mixer stage (BF513).

QUICK REFERENCE DATA

Drain-source voltage	V_{DS}	max.	20	V		
Drain current (d.c. or average)	I_D	max.	30	mA		
Total power dissipation up to $T_{amb} = 65^\circ\text{C}$	P_{tot}	max.	250	mW		
			BF510	511	512	513
Drain current $V_{DS} = 10\text{ V}; V_{GS} = 0$	I_{DSS}	>	0,7	2,5	6	10 mA
		<	3,0	7,0	12	18 mA
Transfer admittance (common source) $V_{DS} = 10\text{ V}; V_{GS} = 0; f = 1\text{ kHz}$	$ y_{fs} $	>	2,5	4	6	7 mS
Feedback capacitance $V_{DS} = 10\text{ V}; V_{GS} = 0$ $V_{DS} = 10\text{ V}; I_D = 5\text{ mA}$	C_{rs}	typ.	0,3	0,3	—	— pF
		typ.	—	—	0,3	0,3 pF
Noise figure at optimum source admittance $G_S = 1\text{ mS}; -B_S = 3\text{ mS}; f = 100\text{ MHz}$	F	typ.	1,5	1,5	—	— dB
		typ.	—	—	1,5	1,5 dB

MECHANICAL DATA

SOT-23.

See also *Soldering recommendations*.

MECHANICAL DATA

Fig. 1 SOT-23

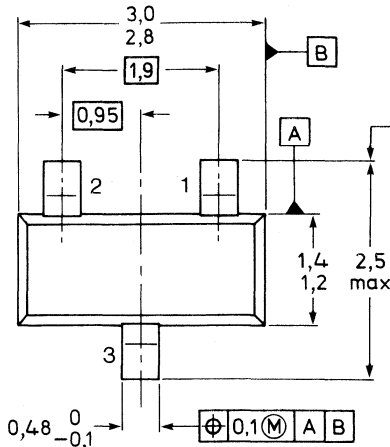
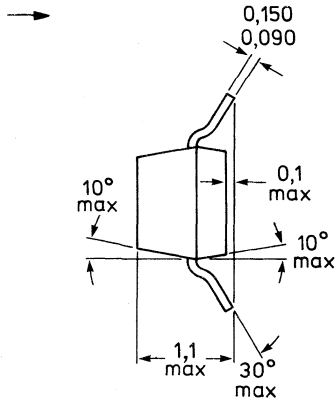

Dimensions in mm

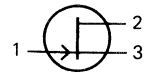

Marking code

- BF510 = S6
- BF511 = S7
- BF512 = S8
- BF513 = S9

7296885

TOP VIEW

RATINGS

Limiting values in accordance with the Absolute Maximum System (IEC 134)

Drain-source voltage see Fig. 4

V_{DS} max. 20 V

Drain-gate voltage (open source) see Fig. 4

V_{DGO} max. 20 V

Drain current (d.c. or average)

I_D max. 30 mA

Gate current

$\pm I_G$ max. 10 mA

Total power dissipation up to $T_{amb} = 60\text{ }^\circ\text{C}^{**}$

P_{tot} max. 250 mW

Storage temperature range

T_{stg} -65 to $+175\text{ }^\circ\text{C}$

Junction temperature

T_j max. $175\text{ }^\circ\text{C}$

THERMAL CHARACTERISTICS*

$$T_j = P \times (R_{th\ j-t} + R_{th\ t-s} + R_{th\ s-a}) + T_{amb}$$

Thermal resistance

From junction to tab

$R_{th\ j-t} = 60\text{ K/W}$

From tab to soldering points

$R_{th\ t-s} = 280\text{ K/W}$

From soldering points to ambient**

$R_{th\ s-a} = 90\text{ K/W}$

* See *Thermal characteristics*.

** Mounted on a ceramic substrate of 8 mm x 10 mm x 0,7 mm.

STATIC CHARACTERISTICS

 $T_{amb} = 25\text{ }^{\circ}\text{C}$

			BF510	511	512	513
Gate cut-off current $-V_{GS} = 0,2\text{ V}; V_{DS} = 0$	$-I_{GSS}$	<	10	10	10	10 nA
Gate-drain breakdown voltage $I_S = 0; -I_D = 10\text{ }\mu\text{A}$	$-V_{(BR)GDO}$	>	20	20	20	20 V
Drain current $V_{DS} = 10\text{ V}; V_{GS} = 0$	I_{DSS}	>	0,7	2,5	6	10 mA
		<	3,0	7,0	12	18 mA
Gate-source cut-off voltage $I_D = 10\text{ }\mu\text{A}; V_{DS} = 10\text{ V}$	$-V_{(P)GS}$	typ.	0,8	1,5	2,2	3 V

DYNAMIC CHARACTERISTICS

Measuring conditions (common source): $V_{DS} = 10\text{ V}; V_{GS} = 0; T_{amb} = 25\text{ }^{\circ}\text{C}$ for BF510 and BF511

$V_{DS} = 10\text{ V}; I_D = 5\text{ mA}; T_{amb} = 25\text{ }^{\circ}\text{C}$ for BF512 and BF513

y-parameters (common source)

			BF510	511	512	513
Input capacitance at $f = 1\text{ MHz}$	C_{is}	<	5	5	5	5 pF
Input conductance at $f = 100\text{ MHz}$	g_{is}	typ.	100	90	60	50 μS
Feedback capacitance at $f = 1\text{ MHz}$	C_{rs}	typ.	0,3	0,3	0,3	0,3 pF
		<	0,4	0,4	0,4	0,4 pF
Transfer admittance at $f = 1\text{ kHz}$ $V_{GS} = 0$ instead of $I_D = 5\text{ mA}$	$ y_{fs} $	>	2,5	4,0	4,0	3,5 mS
		>	—	—	6,0	7,0 mS
Transfer admittance at $f = 100\text{ MHz}$	$ y_{fs} $	typ.	3,5	5,5	5,0	5,0 mS
Output capacitance at $f = 1\text{ MHz}$	C_{os}	<	3	3	3	3 pF
Output conductance at $f = 1\text{ MHz}$	g_{os}	<	60	80	100	120 μS
Output conductance at $f = 100\text{ MHz}$	g_{os}	typ.	35	55	70	90 μS
Noise figure at optimum source admittance $G_S = 1\text{ mS}; -B_S = 3\text{ mS};$ $f = 100\text{ MHz}$	F	typ.	1,5	1,5	1,5	1,5 dB

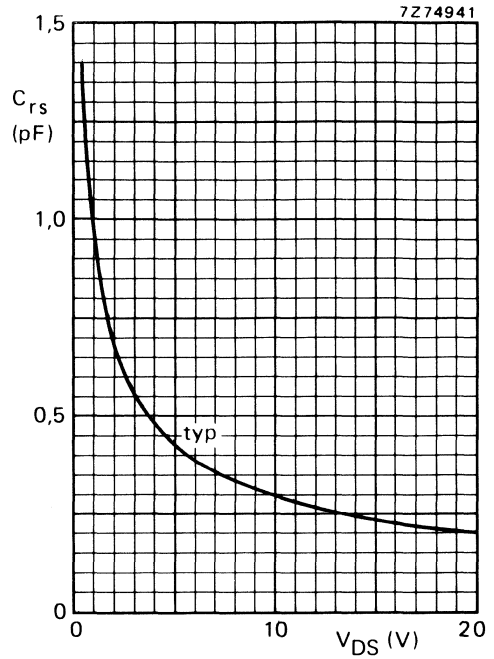

Fig. 2 $V_{GS} = 0$ for BF510 and BF511;
 $I_D = 5$ mA for BF512 and BF513;
 $f = 1$ MHz; $T_{amb} = 25$ °C.

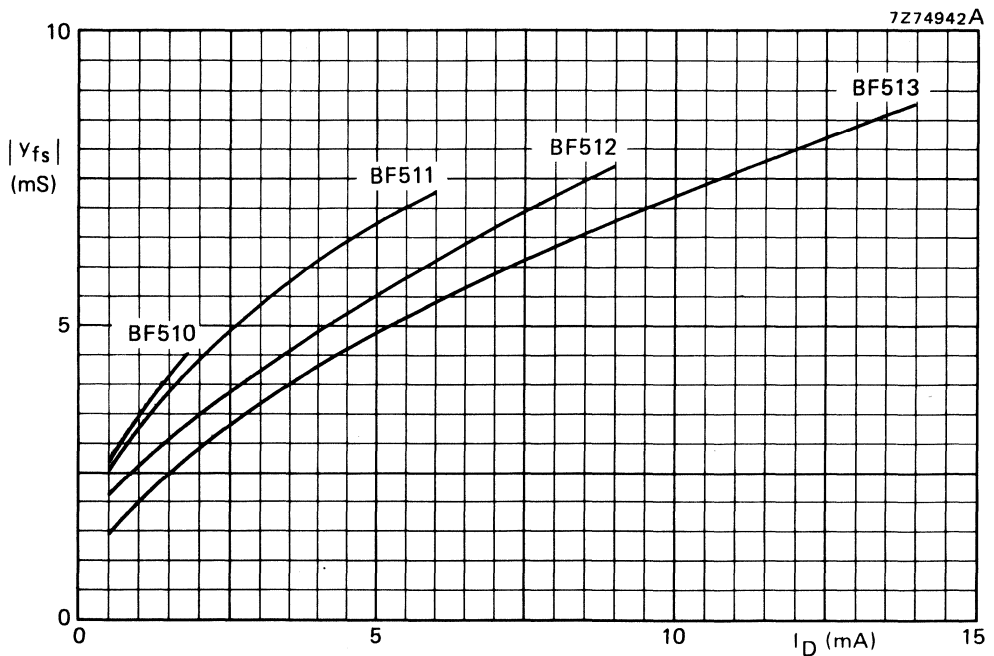

Fig. 3 $V_{DS} = 10$ V; $f = 1$ kHz; $T_{amb} = 25$ °C; typical values.

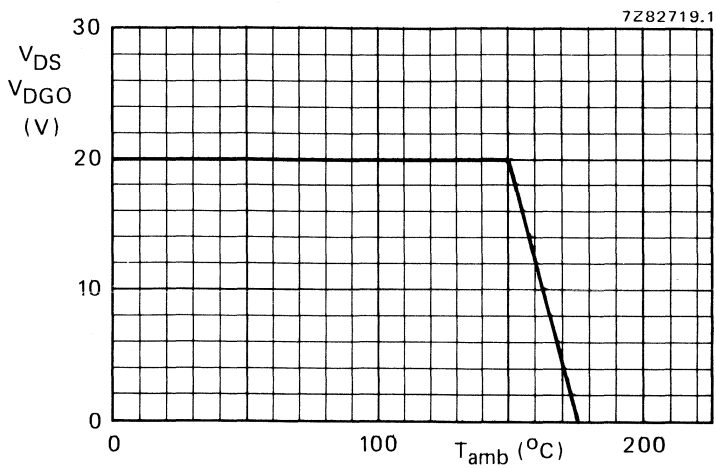

Fig. 4 Voltage derating curve.

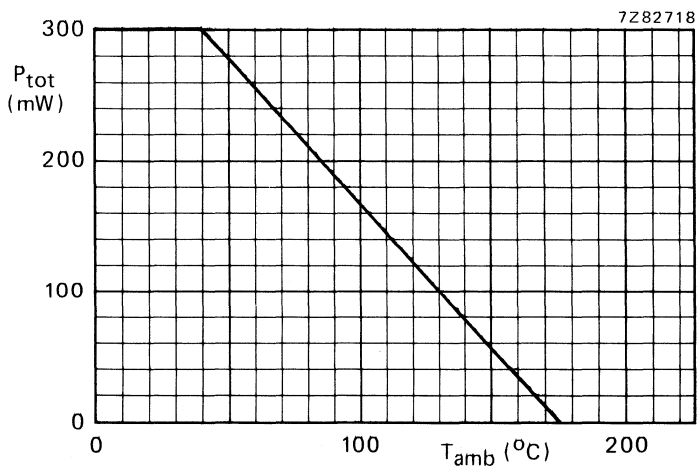

Fig. 5 Power derating curve.

SILICON PLANAR TRANSISTOR

P-N-P transistor in a microminiature plastic envelope. Primarily intended for use as mixer in v.h.f. tuners. Also suitable as r.f. amplifier and oscillator in f.m. tuners.

QUICK REFERENCE DATA

Collector-base voltage (open emitter)	$-V_{CBO}$	max.	30 V
Collector-emitter voltage (open base)	$-V_{CEO}$	max.	30 V
Collector current (d.c.)	$-I_C$	max.	25 mA
Total power dissipation up to $T_{amb} = 60\text{ }^\circ\text{C}$	P_{tot}	max.	200 mW
Junction temperature	T_j	max.	150 $^\circ\text{C}$
D.C. current gain	h_{FE}	>	25
$I_E = 1\text{ mA}; -V_{CB} = 10\text{ V}$			
Transition frequency at $f = 100\text{ MHz}$	f_T	typ.	350 MHz
$I_E = 1\text{ mA}; -V_{CB} = 10\text{ V}$			
Noise figure at $f = 200\text{ MHz}$	F	typ.	5 dB
$I_E = 1\text{ mA}; -V_{CB} = 10\text{ V}$			

MECHANICAL DATA

Fig. 1 SOT-23.

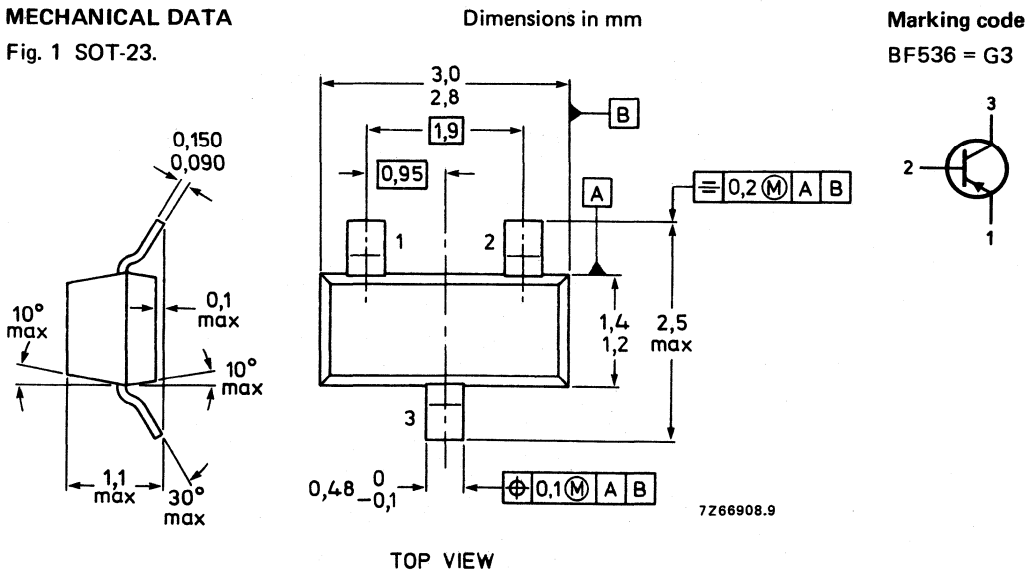

See also *Soldering recommendations*.

RATINGS

Limiting values in accordance with the Absolute Maximum System (IEC 134)

Collector-base voltage (open emitter)	$-V_{CB0}$	max.	30 V
Collector-emitter voltage (open base)	$-V_{CEO}$	max.	30 V
Emitter-base voltage (open collector)	$-V_{EBO}$	max.	4 V
Collector current (d.c.)	$-I_C$	max.	25 mA
Total power dissipation up to $T_{amb} = 60\text{ }^\circ\text{C}^{**}$	P_{tot}	max.	200 mW
Storage temperature	T_{stg}		-65 to $+150\text{ }^\circ\text{C}$
Junction temperature	T_j	max.	150 $^\circ\text{C}$

THERMAL CHARACTERISTICS*

$$T_j = P (R_{th\ j-t} + R_{th\ t-s} + R_{th\ s-a}) + T_{amb}$$

Thermal resistance

From junction to tab	$R_{th\ j-t}$	=	60 K/W
From tab to soldering points	$R_{th\ t-s}$	=	280 K/W
From soldering points to ambient**	$R_{th\ s-a}$	=	90 K/W

CHARACTERISTICS

$T_{amb} = 25\text{ }^\circ\text{C}$; unless otherwise specified

Collector cut-off current

$$I_E = 0; -V_{CB} = 20\text{ V} \quad -I_{CB0} < 50\text{ nA}$$

D.C. current gain

$$I_E = 1\text{ mA}; -V_{CB} = 10\text{ V} \quad h_{FE} > 25$$

Transition frequency at $f = 100\text{ MHz}$

$$I_E = 1\text{ mA}; -V_{CB} = 10\text{ V} \quad f_T \text{ typ. } 350\text{ MHz}$$

Noise figure at $f = 200\text{ MHz}$

$$I_E = 1\text{ mA}; -V_{CB} = 10\text{ V}; R_S = 50\ \Omega \quad F \text{ typ. } 5\text{ dB}$$

Transducer gain (common base) at $f = 200\text{ MHz}$

$$I_E = 3\text{ mA}; -V_{CB} = 10\text{ V}; R_S = 60\ \Omega; R_L = 920\ \Omega \quad G_{tr} \text{ typ. } 17,5\text{ dB}$$

* See *Thermal characteristics*.

** Mounted on a ceramic substrate of 8 mm x 10 mm x 0,7 mm.

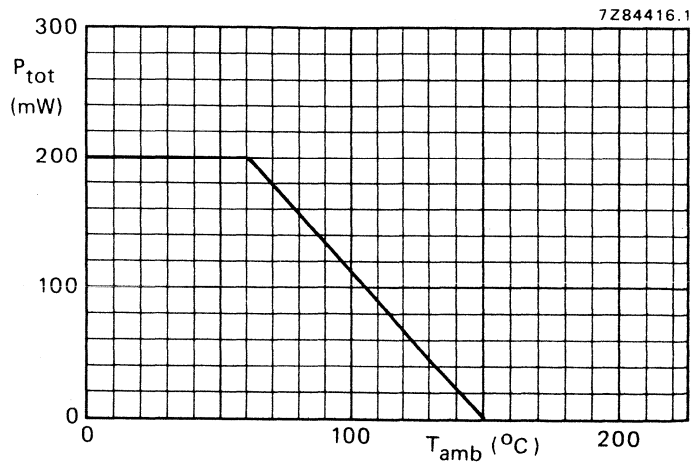

Fig. 2 Power derating curve.

SILICON PLANAR EPITAXIAL TRANSISTOR

P-N-P transistor, in a microminiature plastic envelope, intended for applications in thick and thin-film circuits. This transistor is primarily intended for use in i.f. detection applications.

QUICK REFERENCE DATA

Collector-base voltage (open emitter)	$-V_{CBO}$	max.	40 V
Collector-emitter voltage (open base)	$-V_{CEO}$	max.	40 V
Collector current (d.c.)	$-I_C$	max.	25 mA
Total power dissipation up to $T_{amb} = 60\text{ }^\circ\text{C}$	P_{tot}	max.	200 mW
Junction temperature	T_j	max.	150 $^\circ\text{C}$
D.C. current gain at $T_j = 25\text{ }^\circ\text{C}$ $-I_C = 1\text{ mA}; -V_{CE} = 10\text{ V}$	h_{FE}	>	50
Transition frequency at $f = 100\text{ MHz}$ $-I_C = 1\text{ mA}; -V_{CE} = 10\text{ V}$	f_T	typ.	325 MHz
Noise figure at $R_S = 300\text{ }\Omega$ $-I_C = 1\text{ mA}; -V_{CE} = 10\text{ V}; f = 100\text{ kHz}$	F	typ.	2 dB

MECHANICAL DATA

Fig. 1 SOT-23

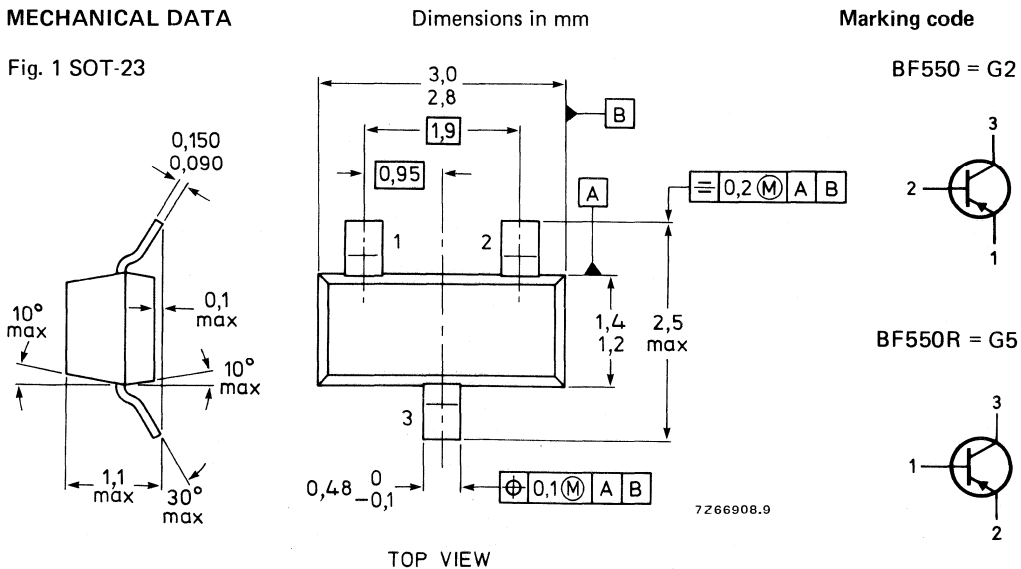

See also *Soldering Recommendations*.

RATINGS

Limiting values in accordance with the Absolute Maximum System (IEC 134)

Collector-base voltage (open emitter)	$-V_{CBO}$	max.	40 V
Collector-emitter voltage (open base)	$-V_{CEO}$	max.	40 V
Emitter-base voltage (open collector)	$-V_{EBO}$	max.	4 V
Collector current (d.c.)	$-I_C$	max.	25 mA
Total power dissipation up to $T_{amb} = 60\text{ }^\circ\text{C}$ **	P_{tot}	max.	200 mW
Storage temperature	T_{stg}		-55 to +150 $^\circ\text{C}$
Junction temperature	T_j	max.	150 $^\circ\text{C}$

THERMAL CHARACTERISTICS*

$$T_j = P_x (R_{th\ j-t} + R_{th\ t-s} + R_{th\ s-a}) + T_{amb}$$

Thermal resistance

From junction to tab	$R_{th\ j-t}$	=	60 K/W
From tab to soldering points	$R_{th\ t-s}$	=	280 K/W
From soldering points to ambient**	$R_{th\ s-a}$	=	90 K/W

CHARACTERISTICS $T_{amb} = 25\text{ }^\circ\text{C}$ unless otherwise specified

Collector cut-off current $I_E = 0; -V_{CB} = 30\text{ V}$	$-I_{CBO}$	<	50 nA
Emitter cut-off current $I_C = 0; -V_{EB} = 3\text{ V}$	$-I_{EBO}$	<	100 μA
Base-emitter voltage $-I_C = 1\text{ mA}; -V_{CE} = 10\text{ V}$	$-V_{BE}$	typ.	750 mV
D.C. current gain $-I_C = 1\text{ mA}; -V_{CE} = 10\text{ V}$	h_{FE}	>	50
Transition frequency at $f = 100\text{ MHz}$ $-I_C = 1\text{ mA}; -V_{CE} = 10\text{ V}$	f_T	typ.	325 MHz
Feedback capacitance at $f = 1\text{ MHz}$ $-I_C = 1\text{ mA}; -V_{CE} = 10\text{ V}$	C_{re}	typ.	0,5 pF
Noise figure at $R_S = 300\ \Omega$ $-I_C = 1\text{ mA}; -V_{CE} = 10\text{ V}; f = 100\text{ kHz}$	F	typ.	2 dB

* See *Thermal characteristics*.

** Mounted on a ceramic substrate of 8 mm x 10 mm x 0,7 mm.

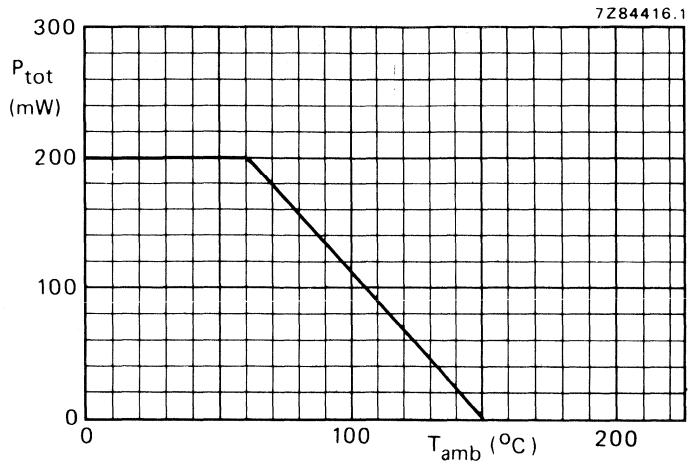

Fig. 2 Power derating curve.

SILICON PLANAR EPITAXIAL TRANSISTOR

P-N-P transistor in a microminiature plastic envelope, intended for applications in thick and thin-film circuits such as self-oscillating mixer in u.h.f. tuners in conjunction with bipolar transistors or with MOS fets.

QUICK REFERENCE DATA

Collector-base voltage (open emitter)	$-V_{CBO}$	max.	40 V
Collector-emitter voltage (open base)	$-V_{CEO}$	max.	35 V
Collector current (d.c.)	$-I_C$	max.	30 mA
Total power dissipation up to $T_{amb} = 60\text{ }^\circ\text{C}$	P_{tot}	max.	200 mW
Junction temperature	T_j	max.	150 $^\circ\text{C}$
Transition frequency at $f = 100\text{ MHz}$ $I_E = 3\text{ mA}; -V_{CB} = 10\text{ V}$	f_T	typ.	900 MHz

MECHANICAL DATA

Dimensions in mm

Fig. 1 SOT-23

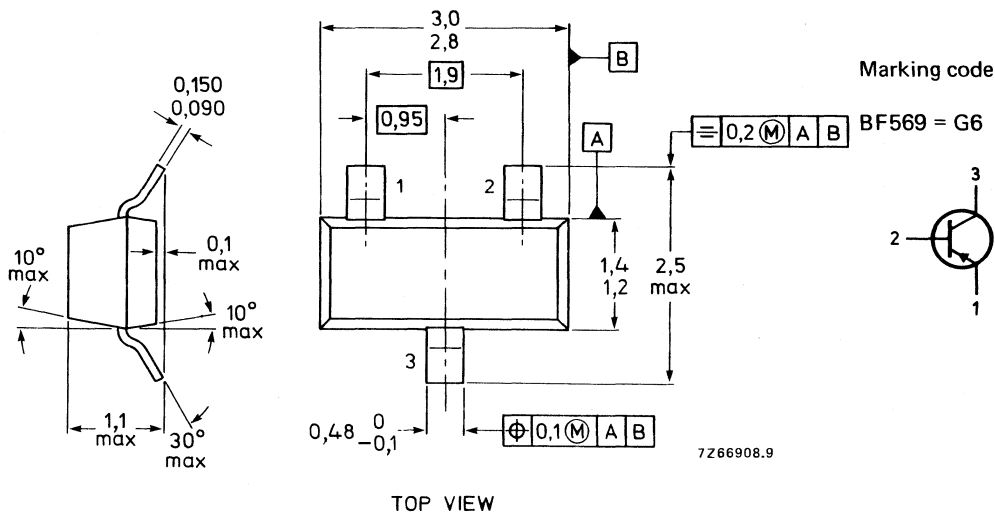

See also *Soldering recommendations.*

RATINGS

Limiting values in accordance with the Absolute Maximum System (IEC 134)

Collector-base voltage (open emitter)	$-V_{CBO}$	max.	40 V
Collector-emitter voltage (open base)	$-V_{CEO}$	max.	35 V
Emitter-base voltage (open collector)	$-V_{EBO}$	max.	3 V
Collector current (d.c.)	$-I_C$	max.	30 mA
Total power dissipation up to $T_{amb} = 60\text{ }^{\circ}\text{C}^{**}$	P_{tot}	max.	200 mW
Storage temperature	T_{stg}		-65 to $+150\text{ }^{\circ}\text{C}$
Junction temperature	T_j	max.	$150\text{ }^{\circ}\text{C}$

THERMAL CHARACTERISTICS*

$$T_j = P \times (R_{th\ j-t} + R_{th\ t-s} + R_{th\ s-a}) + T_{amb}$$

Thermal resistance

From junction to tab	$R_{th\ j-t}$	=	60 K/W
From tab to soldering points	$R_{th\ t-s}$	=	280 K/W
From soldering points to ambient**	$R_{th\ s-a}$	=	90 K/W

CHARACTERISTICS $T_j = 25\text{ }^{\circ}\text{C}$ unless otherwise specified.

Collector cut-off current

$I_E = 0; -V_{CB} = 20\text{ V}$

$-I_{CBO} < 100\text{ nA}$

D.C. current gain

$I_E = 3\text{ mA}; -V_{CB} = 10\text{ V}$

$h_{FE} > \begin{matrix} 25 \\ \text{typ. } 50 \end{matrix}$

Transition frequency at $f = 100\text{ MHz}$

$I_E = 3\text{ mA}; -V_{CB} = 10\text{ V}$

$f_T \text{ typ. } 900\text{ MHz}$

Feedback capacitance at $f = 1\text{ MHz}$

$I_E = 1\text{ mA}; -V_{CB} = 10\text{ V}$

$C_{re} \text{ typ. } 0,33\text{ pF}$

Noise figure at $f = 800\text{ MHz}$

$I_E = 3\text{ mA}; -V_{CB} = 10\text{ V}; R_S = 60\text{ }\Omega; R_L = 500\text{ }\Omega$

$F \text{ typ. } 4,5\text{ dB}$

Power gain at $f = 800\text{ MHz}$

$I_E = 3\text{ mA}; -V_{CB} = 10\text{ V}; R_S = 60\text{ }\Omega; R_L = 500\text{ }\Omega$

$G_{pb} \text{ typ. } 14,5\text{ dB}$

* See *Thermal characteristics*.

** Mounted on a ceramic substrate of 8 mm x 10 mm x 0,7 mm.

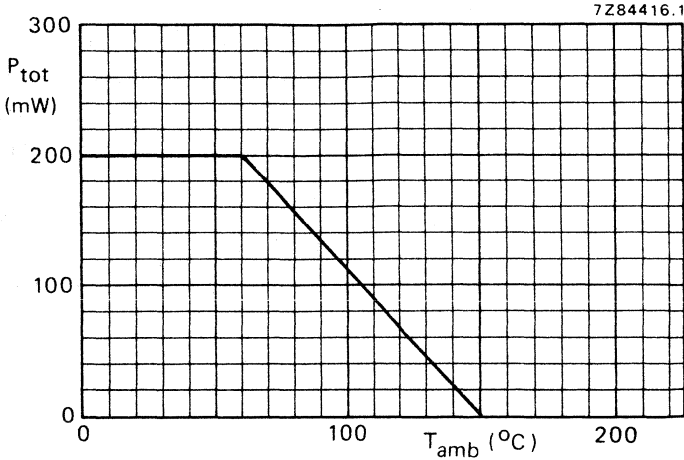

Fig. 2 Power derating curve.

SILICON PLANAR EPITAXIAL TRANSISTOR

N-P-N transistor in a plastic SOT-23 variant envelope, intended for use in large-signal handling i.f. pre-amplifiers of TV receivers in combination with surface acoustic wave filters.

QUICK REFERENCE DATA

Collector-base voltage (open emitter)	V_{CBO}	max.	40 V
Collector-emitter voltage (open base)	V_{CEO}	max.	15 V
Collector current (d.c.)	I_C	max.	100 mA
Total power dissipation up to $T_{amb} = 25\text{ }^\circ\text{C}$	P_{tot}	max.	300 mW
Junction temperature	T_j	max.	150 $^\circ\text{C}$
D.C. current gain $I_C = 10\text{ mA}; V_{CE} = 1\text{ V}$	h_{FE}	>	40
Transition frequency at $f = 100\text{ MHz}$ $I_C = 40\text{ mA}; V_{CE} = 10\text{ V}$	f_T	>	490 MHz
Voltage gain at $f = 36\text{ MHz}$ (see Fig. 4) $I_C = 20\text{ mA}; V_{CE} \approx 10,4\text{ V}$	G_v	typ.	24 dB
Interference voltage for $K = 1\%$ (see Fig. 3)	$V_{(int)rms}$	typ.	120 mV

MECHANICAL DATA

Dimensions in mm

Fig. 1 SOT-23.

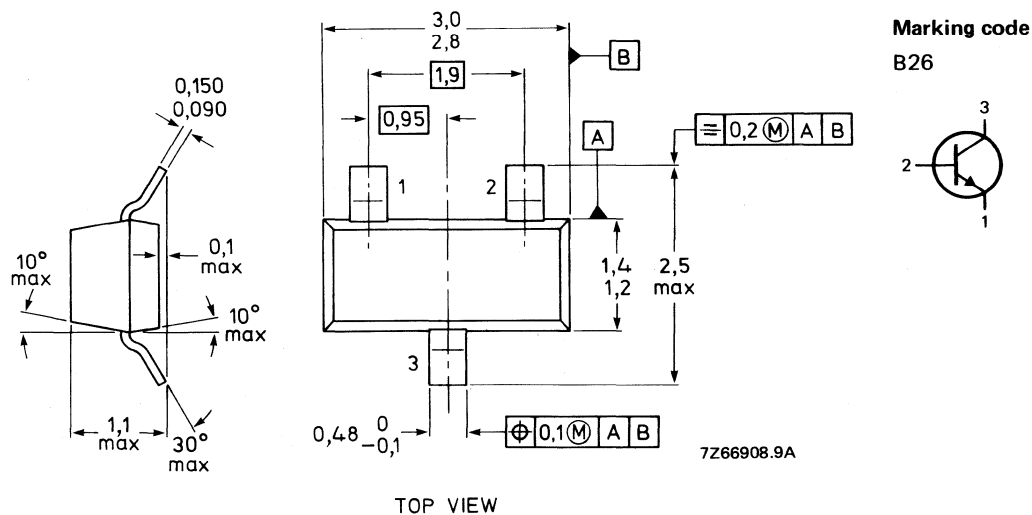

See also *Soldering recommendations.*

RATINGS

Limiting values in accordance with the Absolute Maximum System (IEC 134)

Collector-base voltage (open emitter)	V_{CBO}	max.	40 V
Collector-emitter voltage (open base)	V_{CEO}	max.	15 V
Emitter-base voltage (open collector)	V_{EBO}	max.	4,5 V
Collector current (d.c.)	I_C	max.	100 mA
Total power dissipation up to $T_{amb} = 25\text{ }^\circ\text{C}$	P_{tot}	max.	300 mW
Storage temperature	T_{stg}		-55 to +150 $^\circ\text{C}$
Junction temperature	T_j	max.	150 $^\circ\text{C}$

THERMAL RESISTANCE

From junction to tab	$R_{th\ j-t}$	=	430 K/W
----------------------	---------------	---	---------

CHARACTERISTICS $T_j = 25\text{ }^\circ\text{C}$ unless otherwise specified

Collector cut-off current

$I_E = 0; V_{CB} = 20\text{ V}$

$I_{CBO} < 400\text{ nA}$

$I_E = 0; V_{CB} = 20\text{ V}; T_j = 125\text{ }^\circ\text{C}$

$I_{CBO} < 30\text{ }\mu\text{A}$

Emitter cut-off current

$I_C = 0; V_{EB} = 2\text{ V}$

$I_{EBO} < 100\text{ nA}$

D.C. current gain

$I_C = 10\text{ mA}; V_{CE} = 1\text{ V}$

$h_{FE} > 40$

Transition frequency at $f = 100\text{ MHz}$

$I_C = 10\text{ mA}; V_{CE} = 10\text{ V}$

$f_T > 500\text{ MHz}$

$I_C = 40\text{ mA}; V_{CE} = 10\text{ V}$

$f_T > 490\text{ MHz}$

Collector capacitance at $f = 1\text{ MHz}$

$I_E = I_e = 0; V_{CB} = 10\text{ V}$

C_c typ. 2,2 pF
< 3,5 pF

Emitter capacitance at $f = 1\text{ MHz}$

$I_C = I_c = 0; V_{EB} = 1\text{ V}$

$C_e < 4,5\text{ pF}$

Feedback capacitance at $f = 1\text{ MHz}$

$I_C = 0; V_{CE} = 10\text{ V}$

C_{re} typ. 1,6 pF
< 2,2 pF

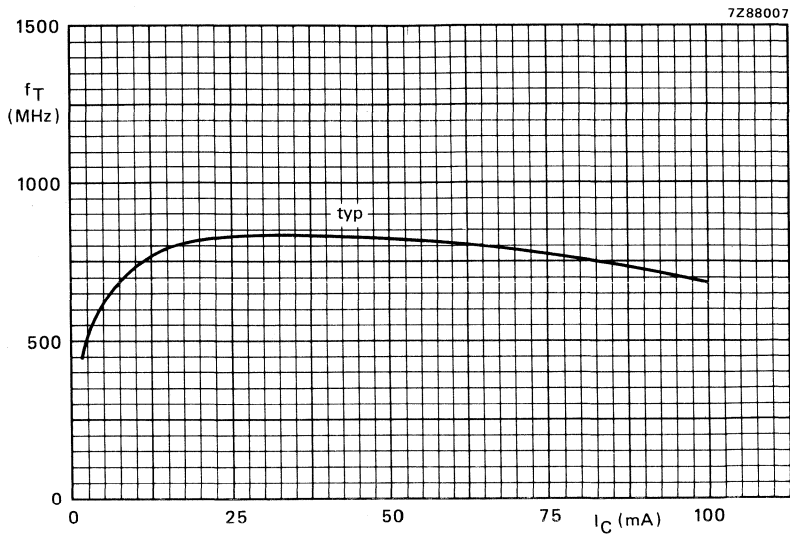
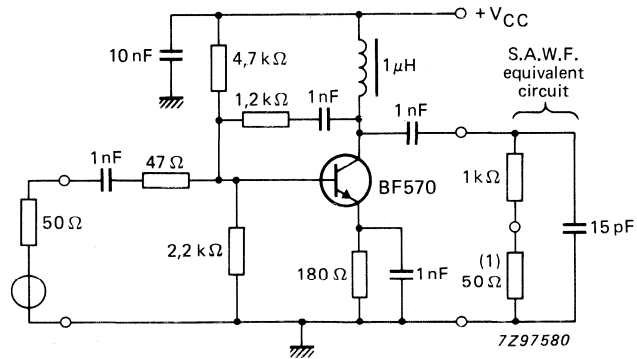

Fig. 2 $V_{CE} = 10 \text{ V}$; $T_j = 25 \text{ }^\circ\text{C}$.

APPLICATION INFORMATION



(1) Test instrument load.

Fig. 3 Large-signal handling i.f. preamplifier for surface acoustic wave filter.

Performance

Supply voltage

V_{CC} = 12 V

Collector current

I_C = 20 mA

Measuring frequency

f_i = 36 MHz

Input impedance

Z_i typ. 50 Ω //1 pF

Output impedance

Z_o < 100 Ω

Voltage gain

$$G_v \text{ (in dB)} = 20 \log \frac{V_o}{V_i}$$

G_v typ. 24 dB

Interference voltage for $K = 1\%*$

$V_{(int)rms}$ typ. 120 mV

* Input terminal voltage at 50 Ω internal resistance of signal generator, interference frequency 40 MHz, 80% modulated with 1 kHz.

SILICON PLANAR TRANSISTOR

P-N-P transistor in a microminiature envelope primarily intended for u.h.f. applications in thick and thin-film circuits.

QUICK REFERENCE DATA

Collector-base voltage (open emitter)	$-V_{CBO}$	max.	20 V
Collector-emitter voltage (open base)	$-V_{CEO}$	max.	20 V
Collector current	$-I_C$	max.	25 mA
Total power dissipation up to $T_{amb} = 85\text{ }^\circ\text{C}$	P_{tot}	max.	150 mW
Junction temperature	T_j	max.	150 $^\circ\text{C}$
Transition frequency at $f = 100\text{ MHz}$ $I_E = 10\text{ mA}; -V_{CB} = 10\text{ V}$	f_T	typ.	1350 MHz
Transducer gain (common base) $I_E = 10\text{ mA}; -V_{CB} = 10\text{ V}; f = 800\text{ MHz}$ $R_S = 60\ \Omega; R_L = 500\ \Omega; T_{amb} = 25\text{ }^\circ\text{C}$	G_{tr}	typ.	16 dB
Noise figure (common base) $I_E = 10\text{ mA}; -V_{CB} = 10\text{ V}; f = 800\text{ MHz}$ $R_S = 60\ \Omega; R_L = 500\ \Omega$	F	typ.	4,5 dB

MECHANICAL DATA

Fig. 1 SOT-23.

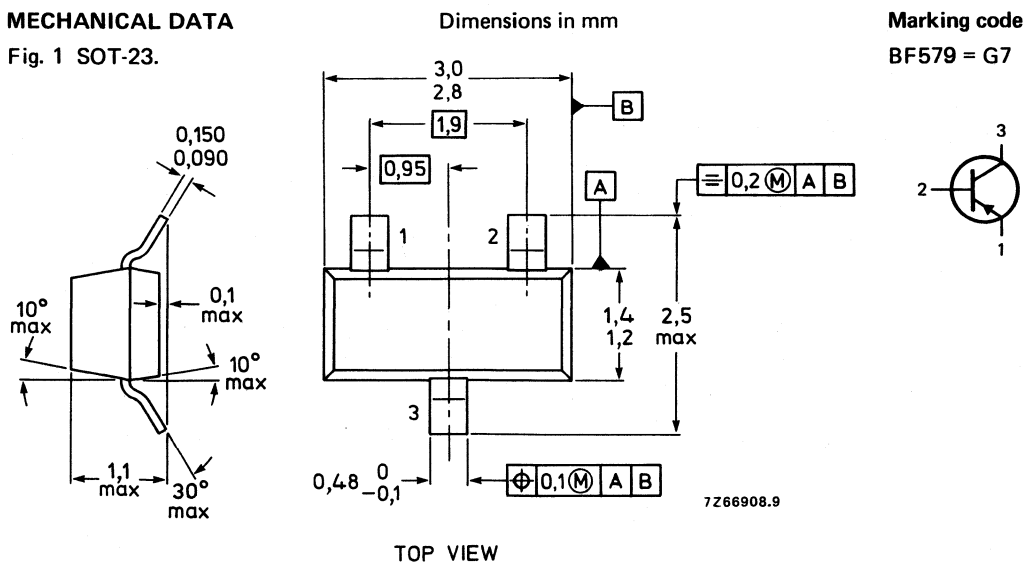

See also *Soldering recommendations*.

RATINGS

Limiting values in accordance with the Absolute Maximum System (IEC 134)

Collector-base voltage (open emitter) see Fig. 2	$-V_{CBO}$	max.	20 V
Collector-emitter voltage (open base) see Fig. 2	$-V_{CEO}$	max.	20 V
Emitter-base voltage (open collector) see Fig. 2	$-V_{EBO}$	max.	3 V
Collector current	$-I_C$	max.	25 mA
Base current (d.c.)	$-I_B$	max.	10 mA
Total power dissipation up to $T_{amb} = 85\text{ }^\circ\text{C}^{**}$	P_{tot}	max.	150 mW
Storage temperature	T_{stg}		-65 to + 150 $^\circ\text{C}$
Junction temperature	T_j	max.	150 $^\circ\text{C}$

THERMAL CHARACTERISTICS*

$$T_j = P \times (R_{th\ j-t} + R_{th\ t-s} + R_{th\ s-a}) + T_{amb}$$

Thermal resistance

From junction to tab	$R_{th\ j-t}$	=	60 K/W
From tab to soldering points	$R_{th\ t-s}$	=	280 K/W
From soldering points to ambient**	$R_{th\ s-a}$	=	90 K/W

CHARACTERISTICS

$T_{amb} = 25\text{ }^\circ\text{C}$

Collector cut-off current

$$I_E = 0; -V_{CB} = 15\text{ V} \quad -I_{CBO} < 100\text{ nA}$$

Emitter cut-off current

$$I_C = 0; -V_{EB} = 1\text{ V} \quad -I_{EBO} < 100\text{ nA}$$

D.C. current gain

$$I_C = 10\text{ mA}; -V_{CE} = 10\text{ V} \quad h_{FE} > 20$$

Transition frequency at $f = 100\text{ MHz}$

$$I_E = 10\text{ mA}; -V_{CB} = 10\text{ V} \quad f_T \text{ typ. } 1350\text{ MHz}$$

Feedback capacitance at $f = 500\text{ kHz}$

$$I_E = 7\text{ mA}; -V_{CB} = 10\text{ V} \quad C_{re} \text{ typ. } 0,46\text{ pF}$$

$$I_E = 0; -V_{CB} = 10\text{ V} \quad C_{rb} \text{ typ. } 160\text{ fF}$$

Transducer gain (common base)

$$I_E = 10\text{ mA}; -V_{CB} = 10\text{ V}; f = 800\text{ MHz} \\ R_S = 60\ \Omega; R_L = 500\ \Omega \quad G_{tr} \text{ typ. } 16\text{ dB}$$

Noise figure (common base)

$$I_E = 10\text{ mA}; -V_{CB} = 10\text{ V}; f = 800\text{ MHz} \\ R_S = 60\ \Omega; R_L = 500\ \Omega \quad F \text{ typ. } 4,5\text{ dB}$$

* See *Thermal characteristics*.

** Mounted on a ceramic substrate of 8 mm x 10 mm x 0,7 mm.

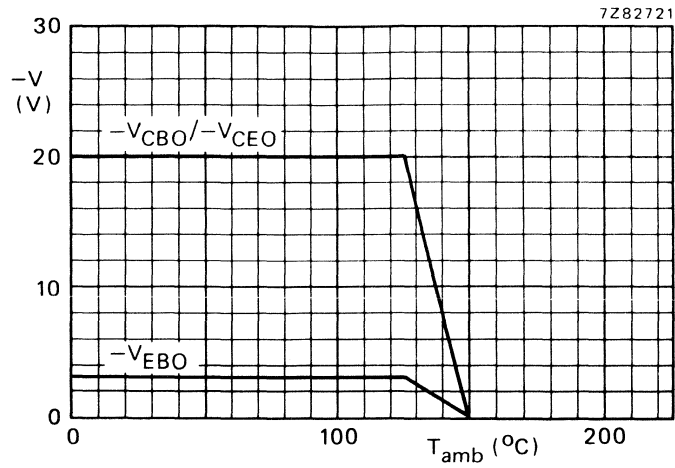

Fig. 2 Voltage derating curves.

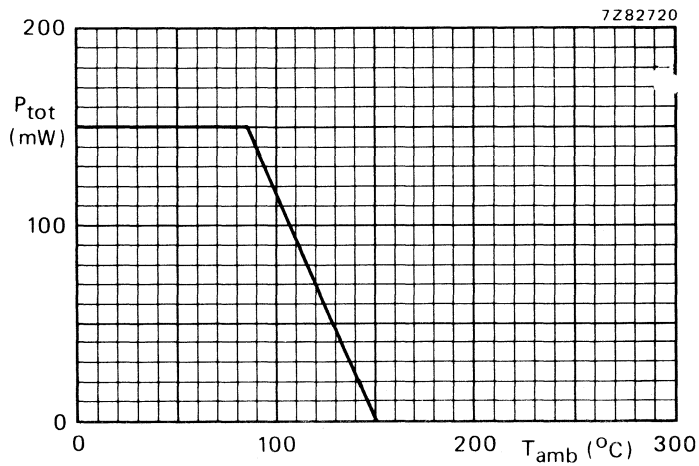

Fig. 3 Power derating curve.

SILICON EPITAXIAL TRANSISTORS

● **For video output stages**

N-P-N transistors in a microminiature plastic envelope intended for class-B video output stages in colour television receivers.

P-N-P complements are BF621 and BF623 respectively.

QUICK REFERENCE DATA

		BF620	BF622
Collector-base voltage (open emitter)	V_{CBO}	max. 300	250 V
Collector-emitter voltage (open base)	V_{CEO}	max. —	250 V
Collector-emitter voltage ($R_{BE} = 2,7 \text{ k}\Omega$)	V_{CER}	max. 300	— V
Collector current (peak value)	I_{CM}	max. 100	mA
Total power dissipation up to $T_{amb} = 25 \text{ }^\circ\text{C}$	P_{tot}	max. 1	W
Junction temperature	T_j	max. 150	$^\circ\text{C}$
D.C. current gain	h_{FE}	> 50	
$I_C = 25 \text{ mA}; V_{CE} = 20 \text{ V}$			
Transition frequency at $f = 35 \text{ MHz}$	f_T	> 60	MHz
$I_C = 10 \text{ mA}; V_{CE} = 10 \text{ V}$			
Feedback capacitance at $f = 1 \text{ MHz}$	C_{re}	< 1,6	pF
$I_C = 0; V_{CE} = 30 \text{ V}$			

MECHANICAL DATA

Fig. 1 SOT-89.

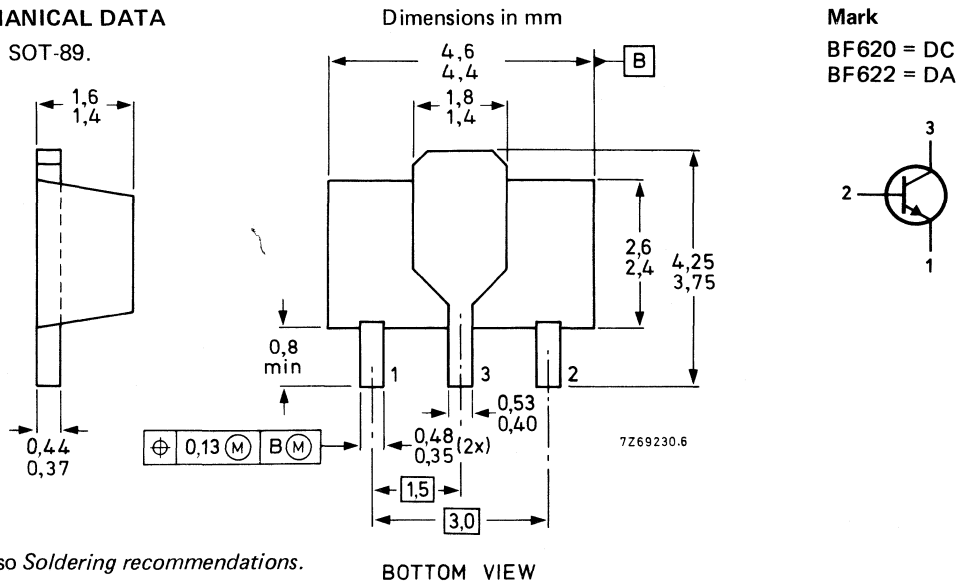

See also *Soldering recommendations.*

RATINGS

Limiting values in accordance with the Absolute Maximum System (IEC 134)

			BF620	BF622
Collector-base voltage (open emitter)	V_{CBO}	max.	300	250 V
Collector-emitter voltage (open base)	V_{CEO}	max.	—	250 V
Collector-emitter voltage ($R_{BE} = 2,7 \text{ k}\Omega$)	V_{CER}	max.	300	— V
Emitter-base voltage (open collector)	V_{EBO}	max.	5 V	
Collector current (d.c.)	I_C	max.	50	mA
Collector current (peak value)	I_{CM}	max.	100	mA
Total power dissipation up to $T_{amb} = 25 \text{ }^\circ\text{C}$ mounted on a ceramic substrate area = $2,5 \text{ cm}^2$; thickness = $0,7 \text{ mm}$	P_{tot}	max.	1	W
Storage temperature	T_{stg}		-65 to + 150 $^\circ\text{C}$	
Junction temperature	T_j	max.	150	$^\circ\text{C}$

THERMAL RESISTANCE*

From junction to collector tab	$R_{th \text{ j-tab}}$	=	25	K/W
From junction to ambient in free air mounted on a ceramic substrate area = $2,5 \text{ cm}^2$; thickness = $0,7 \text{ mm}$	$R_{th \text{ j-a}}$	=	125	K/W

CHARACTERISTICS

			BF620	BF622
$T_j = 25 \text{ }^\circ\text{C}$ unless otherwise specified				
Collector cut-off current $I_E = 0$; $V_{CB} = 200 \text{ V}$	I_{CBO}	<	10	10 nA
Collector-emitter voltage $R_{BE} = 2,7 \text{ k}\Omega$; $V_{CE} = 250 \text{ V}$	I_{CER}	<	50	— nA
$R_{BE} = 2,7 \text{ k}\Omega$; $V_{CE} = 200 \text{ V}$; $T_j = 150 \text{ }^\circ\text{C}$	I_{CER}	<	10	10 μA
Saturation voltage $I_C = 30 \text{ mA}$; $I_B = 5 \text{ mA}$	$V_{CE \text{ sat}}$	<	0,6 V	
D.C. current gain $I_C = 25 \text{ mA}$; $V_{CE} = 20 \text{ V}$	h_{FE}	>	50	
Transition frequency at $f = 35 \text{ MHz}$ $I_C = 10 \text{ mA}$; $V_{CE} = 10 \text{ V}$	f_T	>	60	MHz
Feedback capacitance at $f = 1 \text{ MHz}$ $I_C = 0$; $V_{CE} = 30 \text{ V}$	C_{re}	<	1,6	pF

* See *Thermal characteristics*.

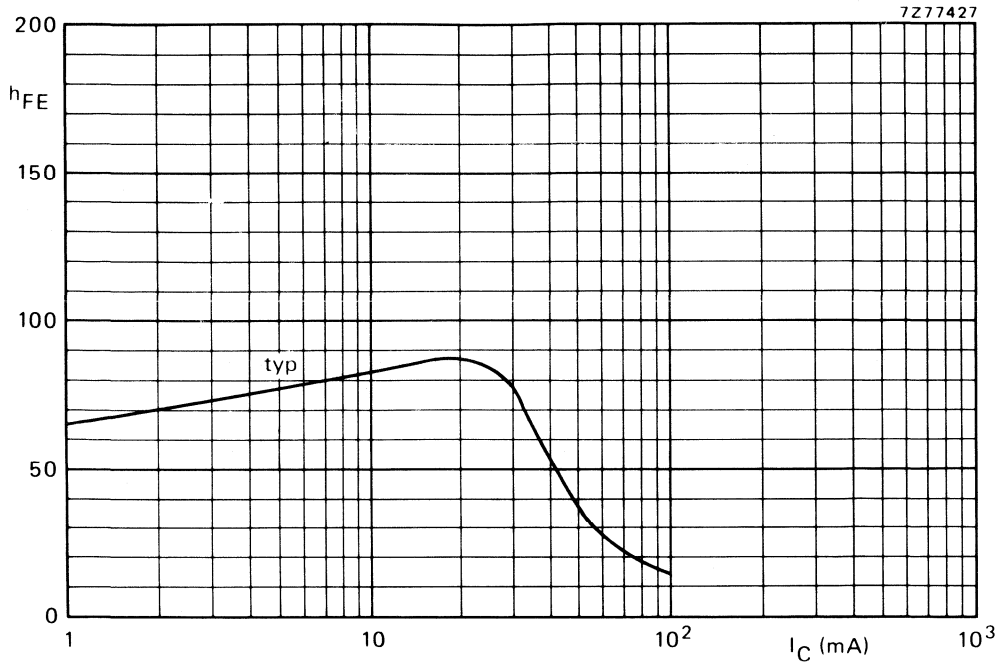

Fig. 2 Typical values at $V_{CE} = 20$ V; $T_j = 25$ °C.

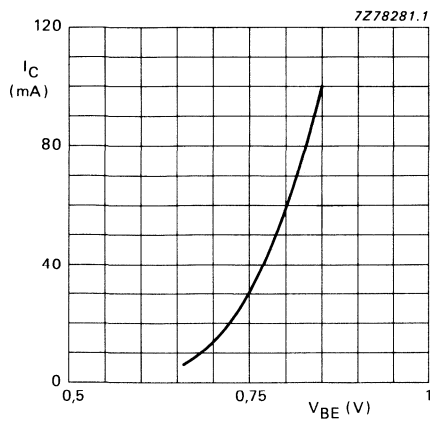

Fig. 3 $V_{CE} = 20$ V; $T_j = 25$ °C.

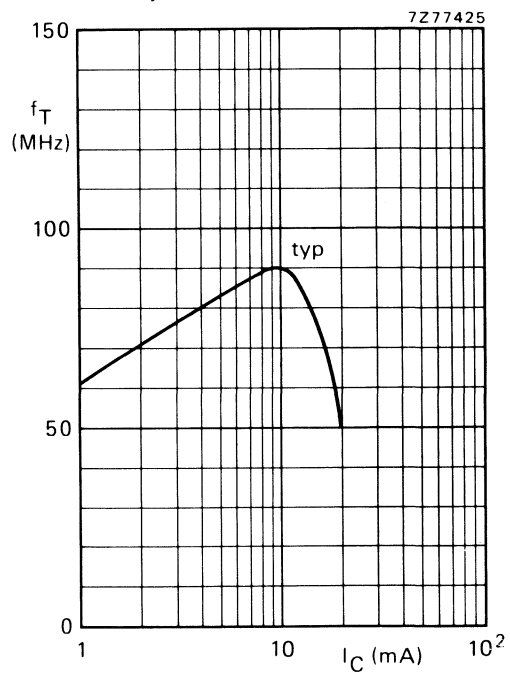

Fig. 4 $V_{CE} = 10$ V; $T_j = 25$ °C; $f = 35$ MHz.

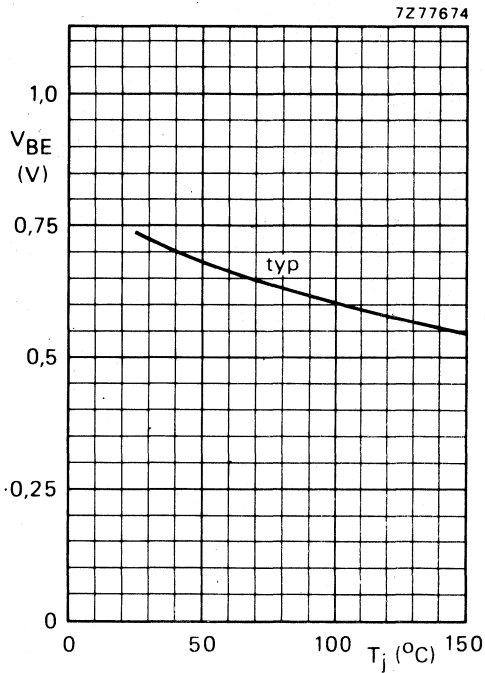

Fig. 5 $I_C = 25$ mA; $V_{CE} = 20$ V.

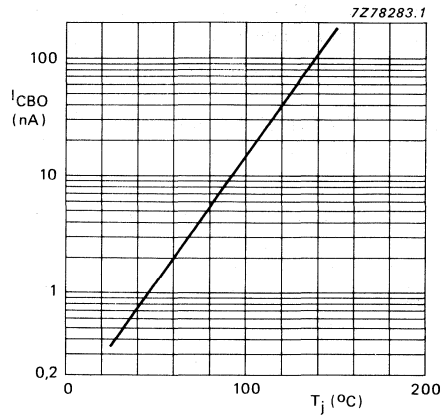

Fig. 6 $V_{CB} = 200$ V; typical values.

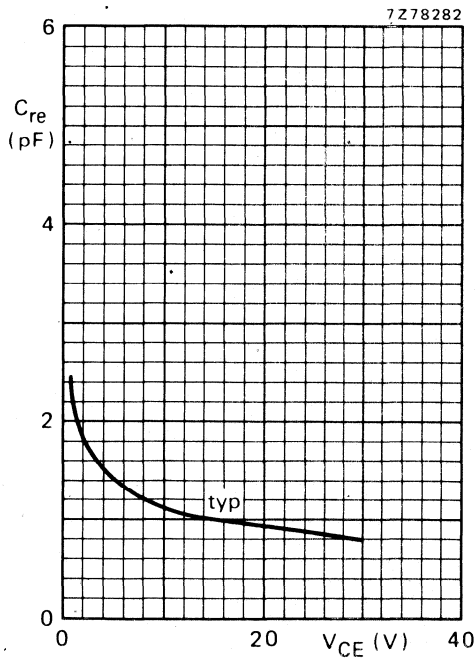

Fig. 7 $I_C = 0$; $f = 1$ MHz; $T_j = 25$ °C.

SILICON EPITAXIAL TRANSISTORS

● For video output stages

P-N-P transistors in a microminiature plastic envelope intended for application in class-B video output stages in colour television receivers.

N-P-N complements are BF620 and BF622 respectively.

QUICK REFERENCE DATA

			BF621	BF623
Collector-base voltage (open emitter)	$-V_{CBO}$	max.	300	250 V
Collector-emitter voltage (open base)	$-V_{CEO}$	max.	—	250 V
Collector-emitter voltage ($R_{BE} = 2,7 \text{ k}\Omega$)	$-V_{CER}$	max.	300	— V
Collector current (peak value)	$-I_{CM}$	max.	100	mA
Total power dissipation up to $T_{amb} = 25 \text{ }^\circ\text{C}$	P_{tot}	max.	1	W
Junction temperature	T_j	max.	150	$^\circ\text{C}$
D.C. current gain	h_{FE}	>	50	
Transition frequency at $f = 35 \text{ MHz}$	f_T	>	60	MHz
Feedback capacitance at $f = 1 \text{ MHz}$	C_{re}	<	1,6	pF

MECHANICAL DATA

Fig. 1 SOT-89.

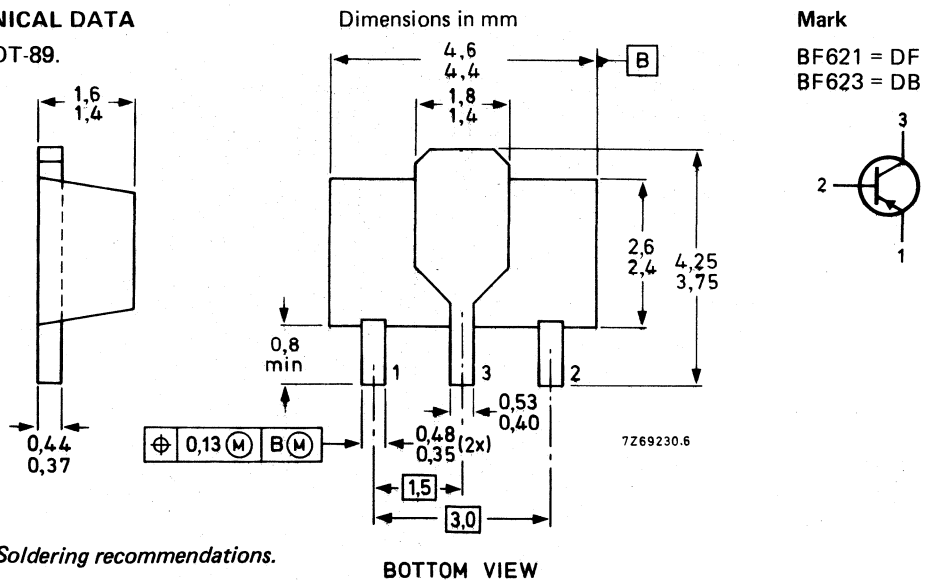

See also *Soldering recommendations*.

RATINGS

Limiting values in accordance with the Absolute Maximum System (IEC 134)

			BF621	BF623
Collector-base voltage (open emitter)	$-V_{CBO}$	max.	300	250 V
Collector-emitter voltage (open base)	$-V_{CEO}$	max.	--	250 V
Collector-emitter voltage ($R_{BE} = 2,7 \text{ k}\Omega$)	$-V_{CER}$	max.	300	-- V
Emitter-base voltage (open collector)	$-V_{EBO}$	max.		5 V
Collector current (d.c.)	$-I_C$	max.		50 mA
Collector current (peak value)	$-I_{CM}$	max.		100 mA
Total power dissipation up to $T_{amb} = 25 \text{ }^\circ\text{C}$ mounted on a ceramic substrate area = $2,5 \text{ cm}^2$; thickness = $0,7 \text{ mm}$	P_{tot}	max.		1 W
Storage temperature	T_{stg}		-65 to +150	$^\circ\text{C}$
Junction temperature	T_j	max.		150 $^\circ\text{C}$

THERMAL RESISTANCE *

From junction to collector tab	$R_{th \text{ j-tab}}$	=	25	K/W
From junction to ambient in free air mounted on a ceramic substrate area = $2,5 \text{ cm}^2$; thickness = $0,7 \text{ mm}$	$R_{th \text{ j-a}}$	=	125	K/W

CHARACTERISTICS

$T_j = 25 \text{ }^\circ\text{C}$ unless otherwise specified

			BF621	BF623
Collector cut-off current $I_E = 0$; $-V_{CB} = 200 \text{ V}$	$-I_{CBO}$	<	10	10 nA
Collector-emitter voltage $R_{BE} = 2,7 \text{ k}\Omega$; $-V_{CE} = 250 \text{ V}$	$-I_{CER}$	<	50	-- nA
$R_{BE} = 2,7 \text{ k}\Omega$; $-V_{CE} = 200 \text{ V}$; $T_j = 150 \text{ }^\circ\text{C}$	$-I_{CER}$	<	10	10 μA
Saturation voltage $-I_C = 30 \text{ mA}$; $-I_B = 5 \text{ mA}$	$-V_{CEsat}$	<		0,8 V
D.C. current gain $-I_C = 25 \text{ mA}$; $-V_{CE} = 20 \text{ V}$	h_{FE}	>		50
Transition frequency at $f = 35 \text{ MHz}$ $-I_C = 10 \text{ mA}$; $-V_{CE} = 10 \text{ V}$	f_T	>		60 MHz
Feedback capacitance at $f = 1 \text{ MHz}$ $I_C = 0$; $-V_{CE} = 30 \text{ V}$	C_{re}	<		1,6 pF

* See *Thermal characteristics*.

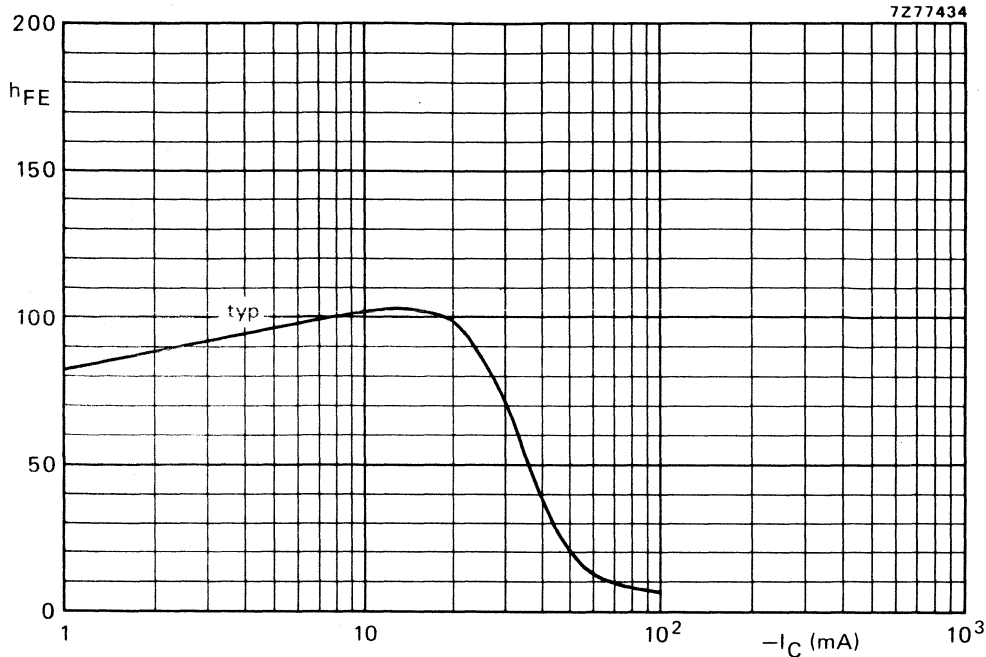

Fig. 2 Typical values at $-V_{CE} = 20$ V; $T_j = 25$ °C.

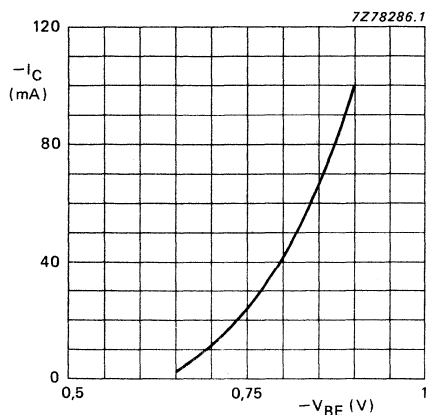

Fig. 3 $-V_{CE} = 20$ V; $T_j = 25$ °C; typical values.

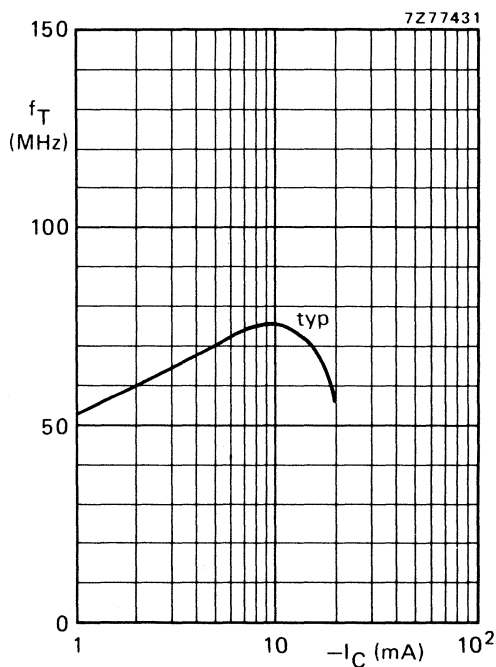

Fig. 4 $-V_{CE} = 10$ V; $T_j = 25$ °C; $f = 35$ MHz.

7Z77674.A

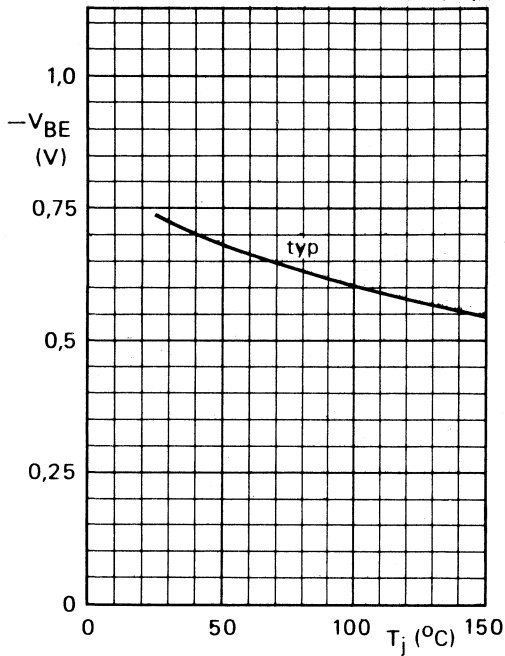

Fig. 5 $-I_C = 25$ mA; $-V_{CE} = 20$ V.

7Z78284.1

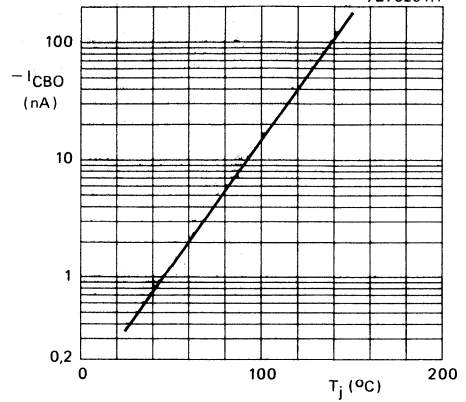

Fig. 6 $-V_{CB} = 200$ V; typical values.

7Z78285

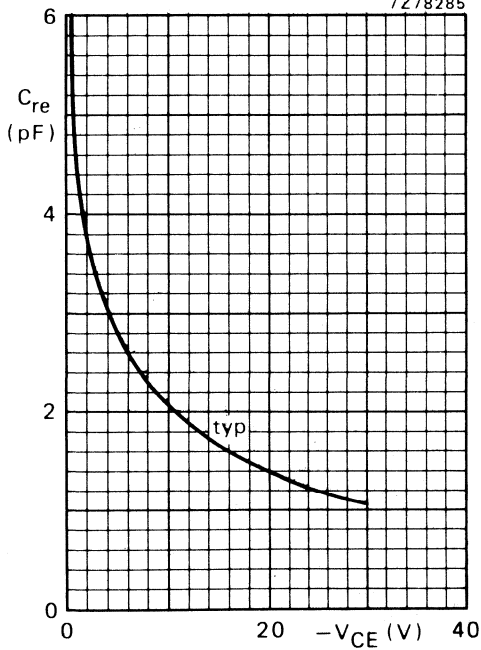

Fig. 7 $I_C = 0$; $f = 1$ MHz; $T_j = 25$ $^{\circ}C$.

SILICON PLANAR TRANSISTOR

P-N-P transistor, in a microminiature plastic envelope; intended for use as oscillator in v.h.f. tuners with extended frequency range and/or in conjunction with MOS-FETs in thick and thin-film circuits.

QUICK REFERENCE DATA

Collector-base voltage (open emitter)	$-V_{CBO}$	max.	40 V
Collector-emitter voltage (open base)	$-V_{CEO}$	max.	30 V
Collector current (peak value)	$-I_{CM}$	max.	25 mA
Total power dissipation up to $T_{amb} = 60\text{ }^{\circ}\text{C}$	P_{tot}	max.	200 mW
Junction temperature	T_j	max.	150 $^{\circ}\text{C}$
Transition frequency at $f = 100\text{ MHz}$ $I_E = 5\text{ mA}; -V_{CB} = 10\text{ V}$	f_T	typ.	650 MHz

MECHANICAL DATA

Fig. 1 SOT-23.

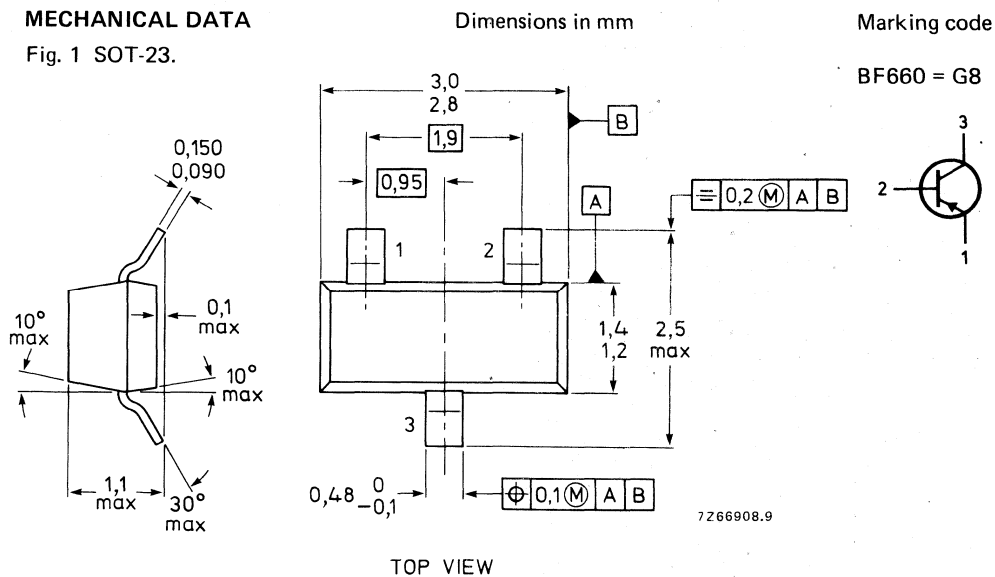

See also *Soldering recommendations*.

RATINGS

Limiting values in accordance with the Absolute Maximum System (IEC 134)

Collector-base voltage (open emitter)	$-V_{CB0}$	max.	40 V
Collector-emitter voltage (open base)	$-V_{CEO}$	max.	30 V
Emitter-base voltage (open collector)	$-V_{EBO}$	max.	4 V
Collector current (peak value)	$-I_{CM}$	max.	25 mA
Base current (d.c.)	$-I_B$	max.	10 mA
Total power dissipation up to $T_{amb} = 60\text{ }^{\circ}\text{C}^{**}$	P_{tot}	max.	200 mW
Storage temperature	T_{stg}		-65 to $+150\text{ }^{\circ}\text{C}$
Junction temperature	T_j	max.	150 $^{\circ}\text{C}$

THERMAL CHARACTERISTICS*

$$T_j = P \times (R_{th\ j-t} + R_{th\ t-s} + R_{th\ s-a}) + T_{amb}$$

Thermal resistance

From junction to tab	$R_{th\ j-t}$	=	60 K/W
From tab to soldering points	$R_{th\ t-s}$	=	280 K/W
From soldering points to ambient ^{***}	$R_{th\ s-a}$	=	90 K/W

CHARACTERISTICS

$$T_{amb} = 25\text{ }^{\circ}\text{C}$$

Collector cut-off current

$$I_E = 0; -V_{CB} = 20\text{ V}$$

$$-I_{CBO} < 50\text{ nA}$$

D.C. current gain

$$I_E = 3\text{ mA}; -V_{CE} = 10\text{ V}$$

$$h_{FE} > 30$$

Transition frequency at $f = 100\text{ MHz}$

$$I_E = 5\text{ mA}; -V_{CB} = 10\text{ V}$$

$$f_T \text{ typ. } 650\text{ MHz}$$

Feedback capacitance at $f = 1\text{ MHz}$

$$I_E = 1\text{ mA}; -V_{CB} = 10\text{ V}$$

$$C_{re} \text{ typ. } 0,65\text{ pF}$$

* See *Thermal characteristics*.

** Mounted on a ceramic substrate of 8 mm x 10 mm x 0,7 mm.

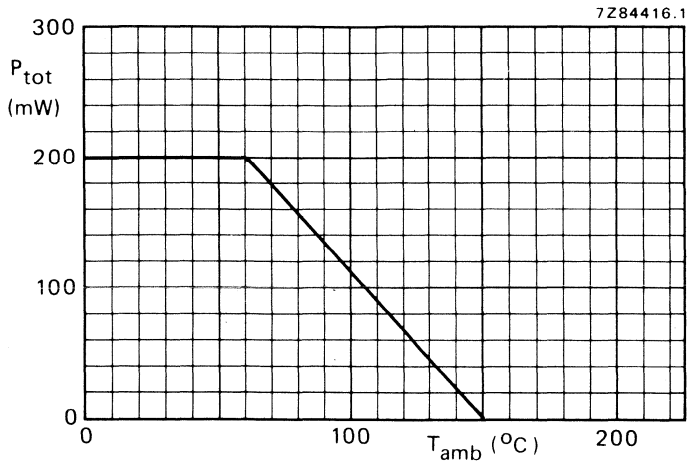

Fig. 2 Power derating curve.

SILICON PLANAR TRANSISTOR

P-N-P transistor in a microminiature plastic envelope, primarily intended for application as gain controlled amplifier e.g. in v.h.f. and u.h.f. television tuners in thick and thin-film circuits.

QUICK REFERENCE DATA

Collector-base voltage (open emitter)	$-V_{CBO}$	max.	30 V
Collector-emitter voltage (open base)	$-V_{CEO}$	max.	30 V
Collector current (d.c.)	$-I_C$	max.	20 mA
Total power dissipation up to $T_{amb} = 60\text{ }^\circ\text{C}$	P_{tot}	max.	200 mW
Junction temperature	T_j	max.	150 $^\circ\text{C}$
Transition frequency at $f = 100\text{ MHz}$ $I_E = 3\text{ mA}; -V_{CB} = 10\text{ V}$	f_T	typ.	900 MHz
Transducer gain (common base) $I_E = 3\text{ mA}; -V_{CB} = 10\text{ V}; f = 800\text{ MHz}$ $R_S = 60\ \Omega; R_L = 500\ \Omega$	G_{tr}	typ.	13 dB
Noise figure (common base) $I_E = 3\text{ mA}; -V_{CB} = 10\text{ V}; f = 800\text{ MHz}$ $R_S = 60\ \Omega; R_L = 500\ \Omega$	F	typ.	4 dB

MECHANICAL DATA

Fig. 1 SOT-23.

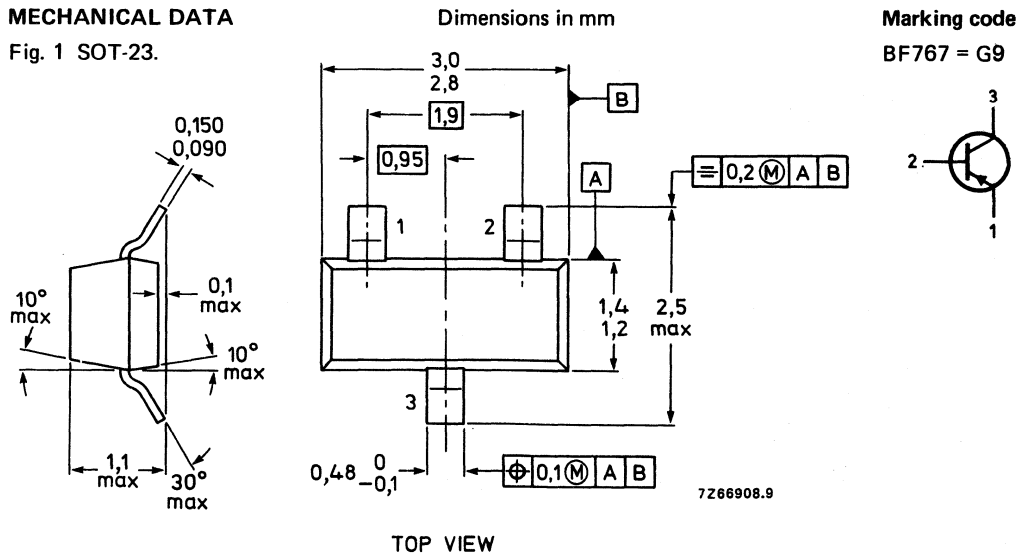

See also *Soldering recommendations*.

RATINGS

Limiting values in accordance with the Absolute Maximum System (IEC 134)

Collector-base voltage (open emitter)	$-V_{CB0}$	max.	30 V
Collector-emitter voltage (open base)	$-V_{CEO}$	max.	30 V
Emitter-base voltage (open collector)	$-V_{EBO}$	max.	3 V
Collector current (d.c.)	$-I_C$	max.	20 mA
Total power dissipation up to $T_{amb} = 60\text{ }^{\circ}\text{C}^{**}$	P_{tot}	max.	200 mW
Storage temperature	T_{stg}		-65 to $+150\text{ }^{\circ}\text{C}$
Junction temperature	T_j	max.	$150\text{ }^{\circ}\text{C}$

THERMAL CHARACTERISTICS*

$$T_j = P \times (R_{th\ j-t} + R_{th\ t-s} + R_{th\ s-a}) + T_{amb}$$

Thermal resistance

From junction to tab	$R_{th\ j-t}$	=	60 K/W
From tab to soldering points	$R_{th\ t-s}$	=	280 K/W
From soldering points to ambient**	$R_{th\ s-a}$	=	90 K/W

CHARACTERISTICS $T_{amb} = 25\text{ }^{\circ}\text{C}$; unless otherwise specified

Collector cut-off current

$$I_E = 0; -V_{CB} = 15\text{ V} \quad -I_{CBO} < 100\text{ nA}$$

D.C. current gain

$$-I_E = 3\text{ mA}; -V_{CB} = 10\text{ V} \quad h_{FE} > 15$$

$$-I_E = 7\text{ mA}; -V_{CB} = 4\text{ V} \quad h_{FE} > 10$$

Transition frequency at $f = 100\text{ MHz}$

$$I_E = 3\text{ mA}; -V_{CB} = 10\text{ V} \quad f_T \text{ typ. } 900\text{ MHz}$$

$$I_E = 7\text{ mA}; -V_{CB} = 5\text{ V} \quad f_T \text{ typ. } 90\text{ MHz}$$

Feedback capacitance at $f = 500\text{ kHz}$

$$I_E = 1\text{ mA}; -V_{CB} = 10\text{ V} \quad C_{re} \text{ typ. } 0,3\text{ pF}$$

$$I_E = 0; -V_{CB} = 10\text{ V} \quad C_{rb} \text{ typ. } 160\text{ fF}$$

Transducer gain (common base)

$$I_E = 3\text{ mA}; -V_{CB} = 10\text{ V}; f = 800\text{ MHz} \\ R_S = 60\text{ }\Omega; R_L = 500\text{ }\Omega \quad G_{tr} \text{ typ. } 13\text{ dB}$$

Noise figure (common base)

$$I_E = 3\text{ mA}; -V_{CB} = 10\text{ V}; f = 800\text{ MHz} \\ R_S = 60\text{ }\Omega; R_L = 500\text{ }\Omega \quad F \text{ typ. } 4\text{ dB}$$

* See *Thermal characteristics*.

** Mounted on a ceramic substrate of 8 mm x 10 mm x 0,7 mm.

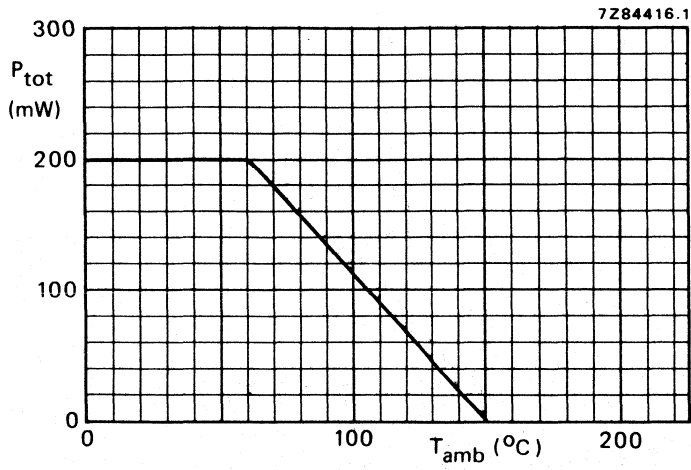

Fig. 2 Power derating curve.

SILICON EPITAXIAL TRANSISTORS

N-P-N transistors in a microminiature plastic envelope intended for application in thick and thin-film circuits. Primarily intended for use in telephony and professional communication equipment. P-N-P components are BF821, BF823 respectively.

QUICK REFERENCE DATA

		BF820	BF822
Collector-base voltage (open emitter)	V_{CBO} max.	300	250 V
Collector-emitter voltage (open base)	V_{CEO} max.	—	250 V
Collector-emitter voltage ($R_{BE} = 2,7 \text{ k}\Omega$)	V_{CER} max.	300	— V
Collector current (peak value)	I_{CM} max.	100	mA
Total power dissipation up to $T_{amb} = 35 \text{ }^\circ\text{C}$	P_{tot} max.	310	mW
Junction temperature	T_j max.	150	$^\circ\text{C}$
D.C. current gain	h_{FE}	>	50
$I_C = 25 \text{ mA}; V_{CE} = 20 \text{ V}$			
Feedback capacitance at $f = 1 \text{ MHz}$	C_{re}	<	1,6 pF
$I_C = 0; V_{CE} = 30 \text{ V}$			
Transition frequency at $f = 35 \text{ MHz}$	f_T	>	60 MHz
$I_C = 10 \text{ mA}; V_{CE} = 10 \text{ V}$			

MECHANICAL DATA

Fig. 1 SOT-23.

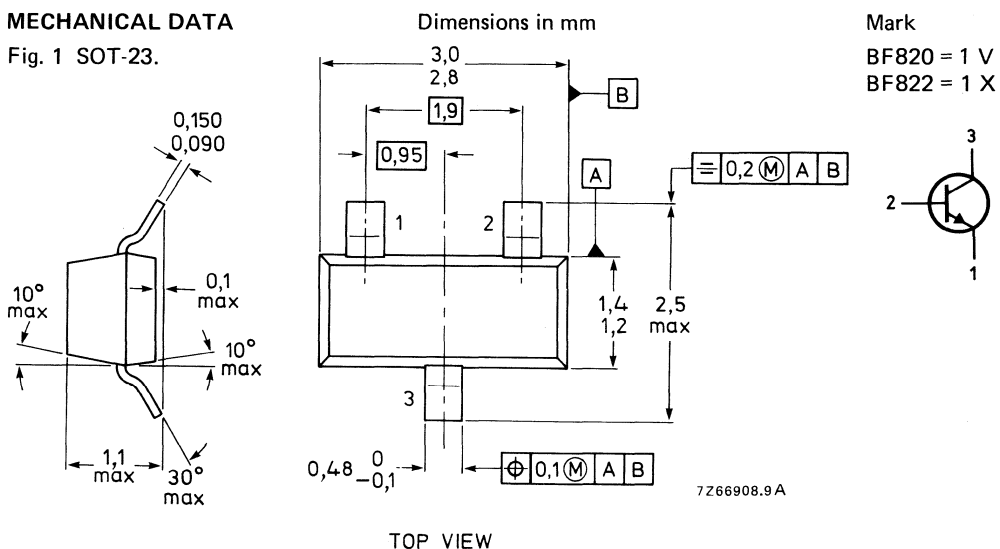

See also *Soldering recommendations*.

RATINGS

Limiting values in accordance with the Absolute Maximum System (IEC 134)

		BF820	BF822
Collector-base voltage (open emitter)	V _{CB0} max.	300	250 V
Collector-emitter voltage (open base)	V _{CEO} max.	—	250 V
Collector-emitter voltage (R _{BE} = 2,7 kΩ)	V _{CER} max.	300	— V
Emitter-base voltage (open collector)	V _{EBO} max.		5 V
Collector current (d.c.)	I _C max.		50 mA
Collector current (peak value)	I _{CM} max.		100 mA
Total power dissipation* up to T _{amb} = 35 °C	P _{tot} max.		310 mW
Storage temperature	T _{stg}		−65 to +150 °C
Junction temperature	T _j max.		150 °C

THERMAL CHARACTERISTICS**

$$T_j = P(R_{th\ j-t} + R_{th\ t-s} + R_{th\ s-a}) + T_{amb}$$

Thermal resistance

from junction to tab

$$R_{th\ j-t} = 50 \text{ K/W}$$

from tab to soldering points

$$R_{th\ t-s} = 260 \text{ K/W}$$

from soldering points to ambient*

$$R_{th\ s-a} = 60 \text{ K/W}$$

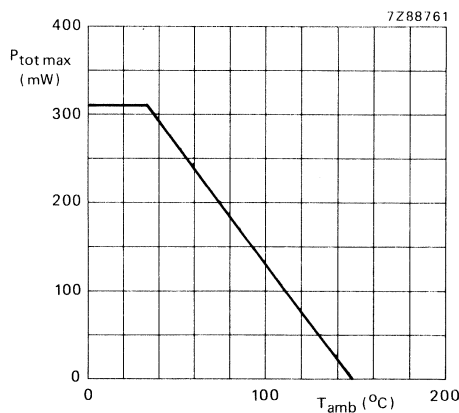

Fig. 2 Power derating curve.

* Mounted on a ceramic substrate: area = 2,5 cm²; thickness = 0,7 mm.

** See *Thermal characteristics*.

CHARACTERISTICS

 $T_j = 25\text{ }^\circ\text{C}$ unless otherwise specified

Collector cut-off current

$I_E = 0; V_{CB} = 200\text{ V}$

	BF820	BF822
I_{CBO}	< 10	10 nA
I_{CER}	< 50	50 nA
I_{CER}	< 10	10 μA
$V_{CE\text{ sat}}$	< 0,6	V
h_{FE}	> 50	
f_T	> 60	MHz
C_{re}	< 1,6	pF

Collector-emitter voltage

$R_{BE} = 2,7\text{ k}\Omega; V_{CE} = 250\text{ V}$

$R_{BE} = 2,7\text{ k}\Omega; V_{CE} = 200\text{ V}; T_j = 150\text{ }^\circ\text{C}$

Saturation voltage

$I_C = 30\text{ mA}; I_B = 5\text{ mA}$

D.C. current gain

$I_C = 25\text{ mA}; V_{CE} = 20\text{ V}$

Transition frequency at $f = 35\text{ MHz}$

$I_C = 10\text{ mA}; V_{CE} = 10\text{ V}$

Feedback capacitance at $f = 1\text{ MHz}$

$I_C = 0; V_{CE} = 30\text{ V}$

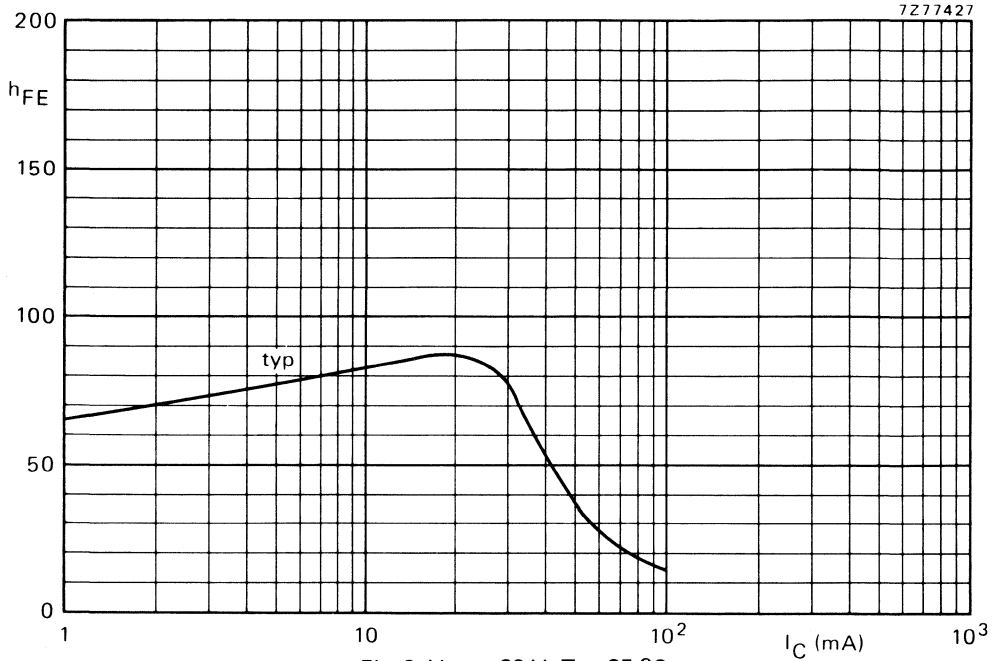

Fig. 3 $V_{CE} = 20\text{ V}$; $T_j = 25\text{ }^\circ\text{C}$.

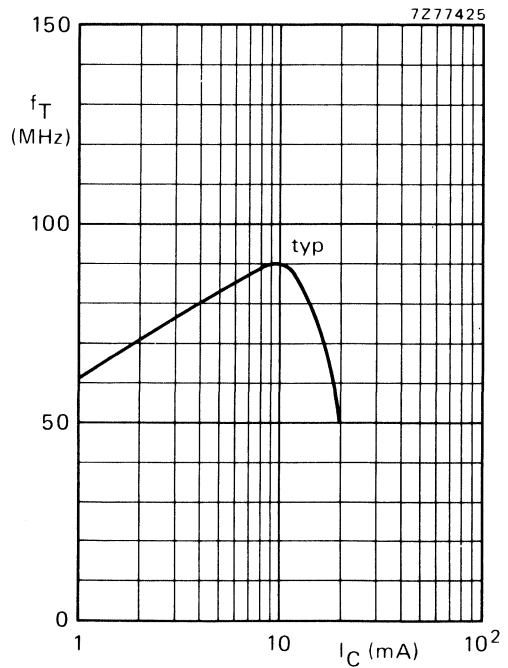

Fig. 5 $V_{CE} = 10\text{ V}$; $T_j = 25\text{ }^\circ\text{C}$, $f = 35\text{ MHz}$.

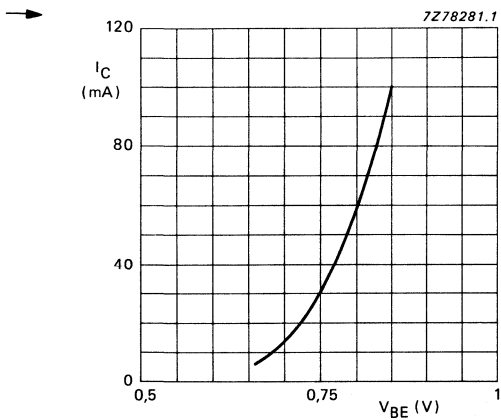

Fig. 4 $V_{CE} = 20\text{ V}$; $T_j = 25\text{ }^\circ\text{C}$; typical values.

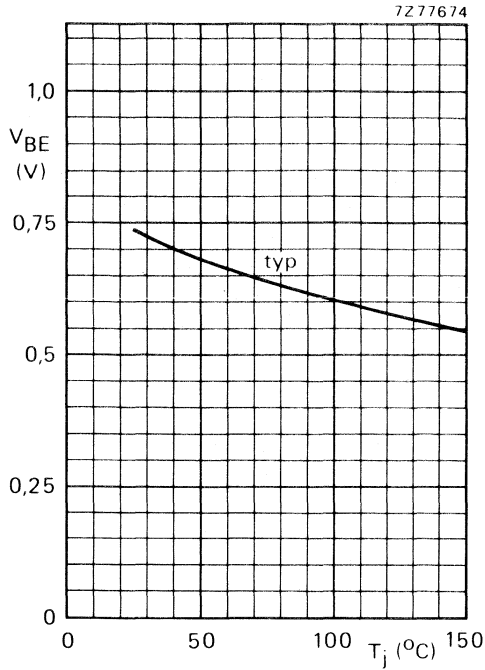

Fig. 6 $I_C = 25$ mA; $V_{CE} = 20$ V.

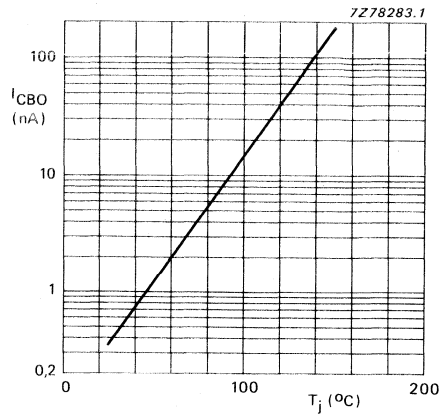

Fig. 7 $V_{CB} = 200$ V; typical values.

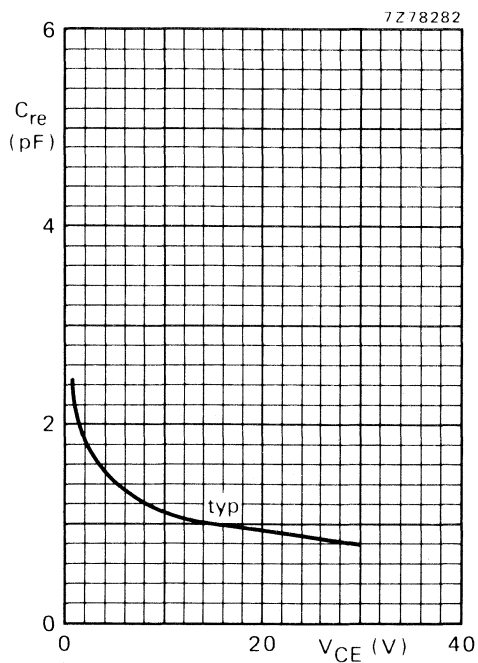

Fig. 8 $I_C = 0$; $f = 1$ MHz; $T_j = 25$ °C.

SILICON EPITAXIAL TRANSISTORS

P-N-P transistors in a microminiature plastic envelope intended for application in thick and thin-film circuits. Primarily intended for use in telephony and professional communication equipment. N-P-N complements are BF820, BF822 respectively.

QUICK REFERENCE DATA

		BF821	BF823
Collector-base voltage (open emitter)	$-V_{CB0}$ max.	300	250 V
Collector-emitter voltage (open base)	$-V_{CEO}$ max.	—	250 V
Collector-emitter voltage ($R_{BE} = 2,7 \text{ k}\Omega$)	$-V_{CER}$ max.	300	— V
Collector current (peak value)	$-I_{CM}$ max.	100	mA
Total power dissipation up to $T_{amb} = 35 \text{ }^\circ\text{C}$	P_{tot} max.	310	mW
Junction temperature	T_j max.	150	$^\circ\text{C}$
D.C. current gain	h_{FE}	>	50
$-I_C = 25 \text{ mA}; -V_{CE} = 20 \text{ V}$			
Feedback capacitance at $f = 1 \text{ MHz}$	C_{re}	<	1,6 pF
$-I_C = 0; -V_{CE} = 30 \text{ V}$			
Transition frequency at $f = 35 \text{ MHz}$	f_T	>	60 MHz
$-I_C = 10 \text{ mA}; -V_{CE} = 10 \text{ V}$			

MECHANICAL DATA

Fig. 1 SOT-23.

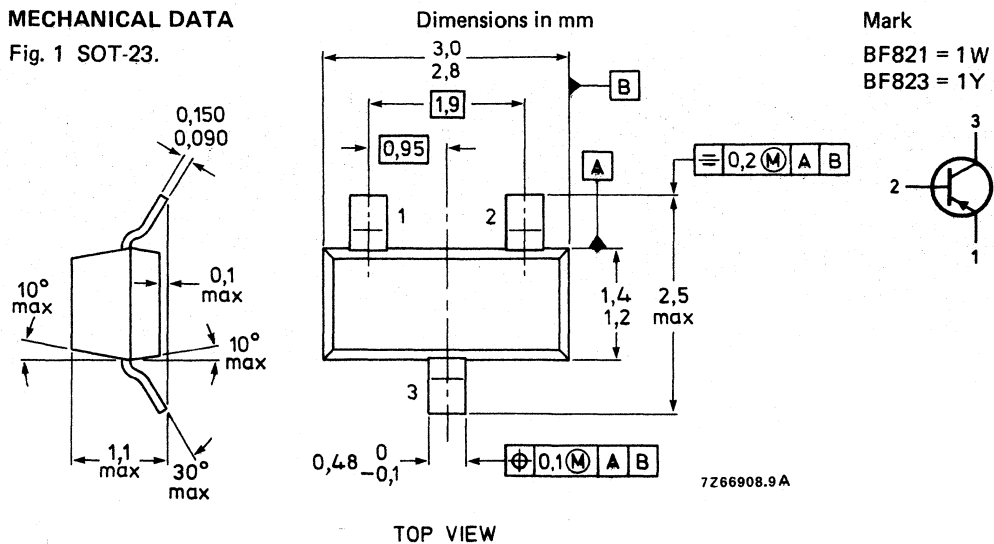

See also *Soldering recommendations*.

RATINGS

Limiting values in accordance with the Absolute Maximum System (IEC 134)

		BF821	BF823
Collector-base voltage (open emitter)	$-V_{CBO}$ max.	300	250 V
Collector-emitter voltage (open base)	$-V_{CEO}$ max.	—	250 V
Collector-emitter voltage ($R_{BE} = 2,7 \text{ k}\Omega$)	$-V_{CER}$ max.	300	— V
Emitter-base voltage (open collector)	$-V_{EBO}$ max.		5 V
Collector current (d.c.)	$-I_C$ max.		50 mA
Collector current (peak value)	$-I_{CM}$ max.		100 mA
Total power dissipation * up to $T_{amb} = 35 \text{ }^\circ\text{C}$	P_{tot} max.	310	mW
Storage temperature	T_{stg}		-65 to +150 $^\circ\text{C}$
Junction temperature	T_j max.		150 $^\circ\text{C}$

THERMAL CHARACTERISTICS**

$$T_j = P(R_{th \text{ j-t}} + R_{th \text{ t-s}} + R_{th \text{ s-a}}) + T_{amb}$$

Thermal resistance

from junction to tab

from tab to soldering points

from soldering points to ambient *

$R_{th \text{ j-t}}$	=	50	K/W
$R_{th \text{ t-s}}$	=	260	K/W
$R_{th \text{ s-a}}$	=	60	K/W

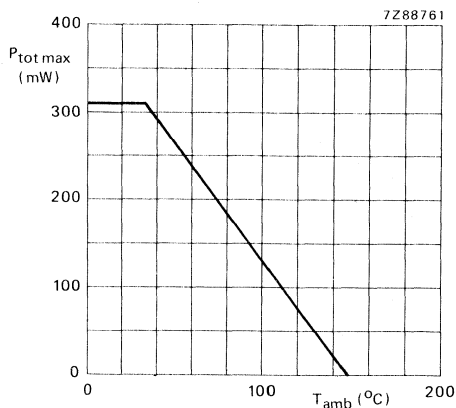

Fig. 2 Power derating curve.

* Mounted on a ceramic substrate: area = 2,5 cm²; thickness = 0,7 mm.

** See *Thermal characteristics*.

CHARACTERISTICS

 $T_j = 25\text{ }^\circ\text{C}$ unless otherwise specified

Collector cut-off current

$I_E = 0; -V_{CB} = 200\text{ V}$

	BF821	BF823
$-I_{CBO}$	< 10	10 nA
$-I_{CER}$	< 50	50 nA
$-I_{CER}$	< 10	10 μA
$-V_{CEsat}$	< 0,8	V
h_{FE}	> 50	
f_T	> 60	MHz
C_{re}	< 1,6	pF

Collector-emitter voltage

$R_{BE} = 2,7\text{ k}\Omega; -V_{CE} = 250\text{ V}$

$R_{BE} = 2,7\text{ k}\Omega; -V_{CE} = 200\text{ V}; T_j = 150\text{ }^\circ\text{C}$

Saturation voltage

$-I_C = 30\text{ mA}; -I_B = 5\text{ mA}$

D.C. current gain

$-I_C = 25\text{ mA}; -V_{CE} = 20\text{ V}$

Transition frequency at $f = 35\text{ MHz}$

$-I_C = 10\text{ mA}; -V_{CE} = 10\text{ V}$

Feedback capacitance at $f = 1\text{ MHz}$

$I_C = 0; -V_{CE} = 30\text{ V}$

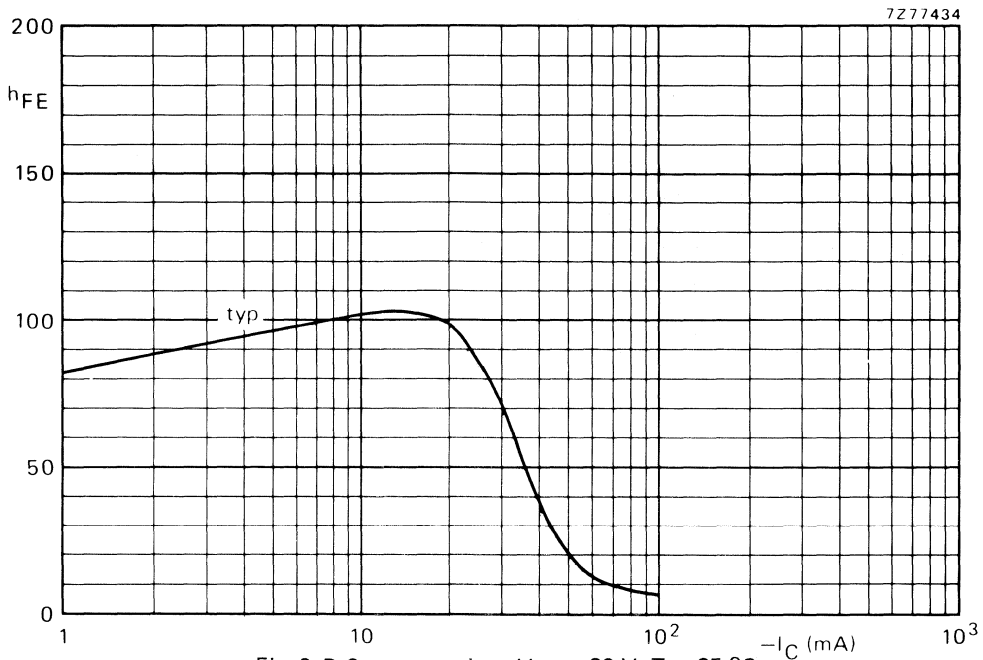

Fig. 3 D.C. current gain. $-V_{CE} = 20$ V; $T_j = 25$ °C.

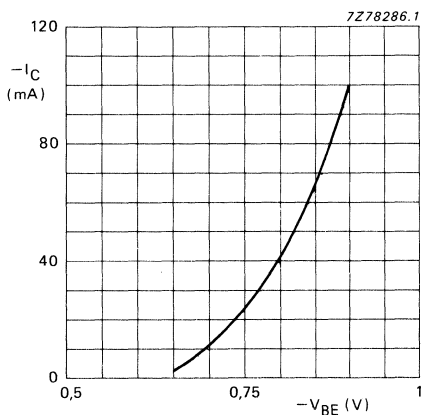

Fig. 4 $-V_{CE} = 20$ V; $T_j = 25$ °C; typical values.

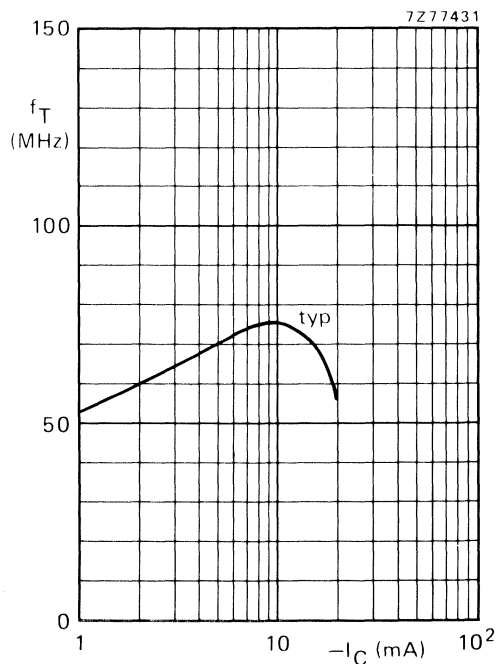

Fig. 5 $-V_{CE} = 10$ V; $T_j = 25$ °C; $f = 35$ MHz.

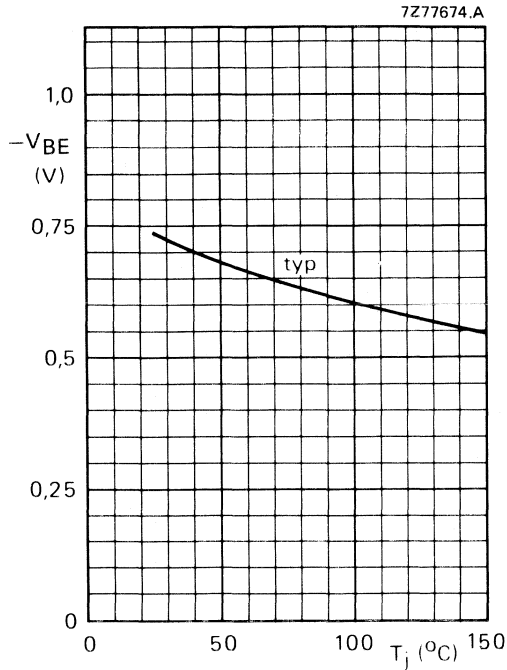

Fig. 6 $-I_C = 25$ mA; $-V_{CE} = 20$ V.

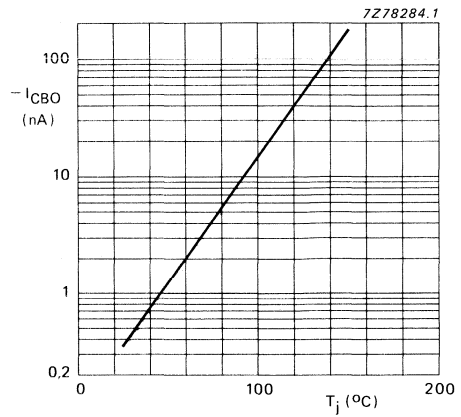

Fig. 7 $-V_{CB} = 200$ V; typical values.

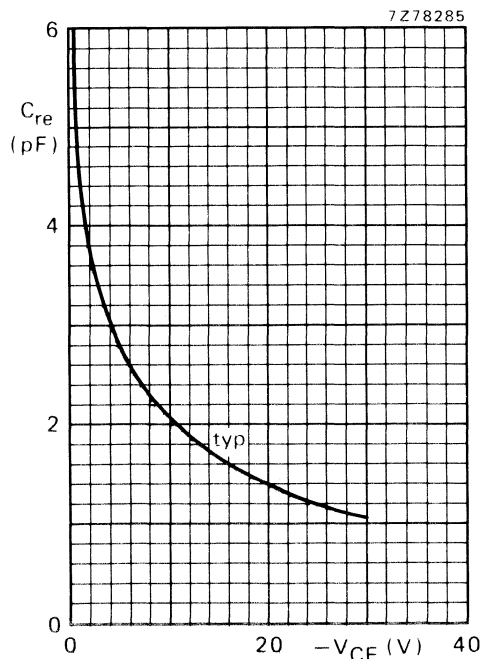

Fig. 8 $I_C = 0$; $f = 1$ MHz; $T_j = 25$ °C.

H.F. SILICON PLANAR EPITAXIAL TRANSISTOR

P-N-P transistor in a plastic SOT-23 envelope especially intended for r.f. stages in f.m. front-ends in common base configuration for SMD applications.

QUICK REFERENCE DATA

Collector-base voltage (open emitter)	$-V_{CB0}$	max.	30 V
Collector-emitter voltage (open base)	$-V_{CEO}$	max.	30 V
Collector current (d.c.)	$-I_C$	max.	25 mA
Total power dissipation up to $T_{amb} = 25\text{ }^\circ\text{C}$	P_{tot}	max.	300 mW
Junction temperature	T_j	max.	150 $^\circ\text{C}$
Base current		typ.	80 μA
$-I_C = 4\text{ mA}; -V_{CE} = 10\text{ V}$	$-I_B$	<	160 μA
Transition frequency		typ.	450 MHz
$-I_C = 4\text{ mA}; -V_{CE} = 10\text{ V}$	f_T		
Noise figure at $f = 100\text{ MHz}$		typ.	3 dB
$-I_C = 2\text{ mA}; -V_{CE} = 10\text{ V}; G_S = 16,7\text{ mS}$	F		
Feedback capacitance at $f = 1\text{ MHz}$		typ.	0,1 pF
$V_{EB} = 0; -V_{CB} = 10\text{ V}$	C_{rb}		

MECHANICAL DATA

Fig. 1 SOT-23.

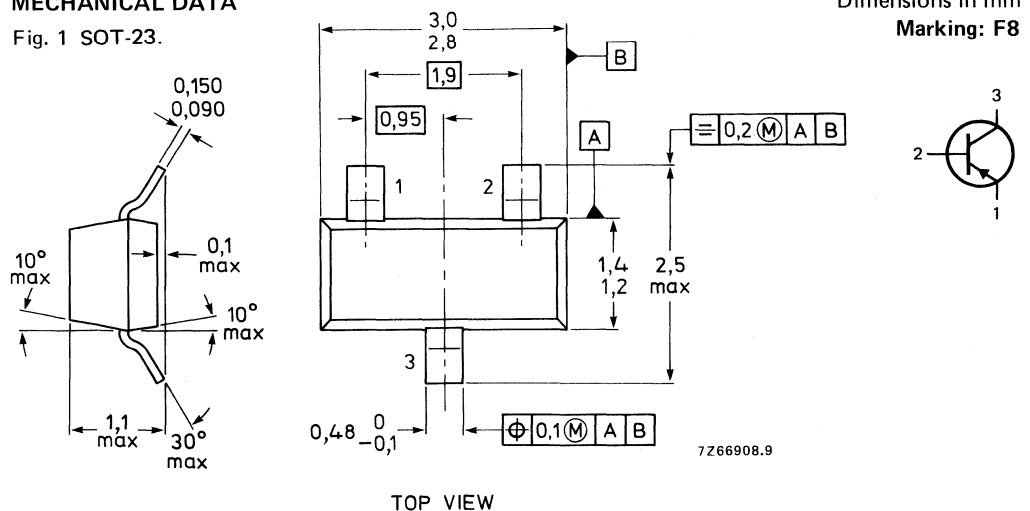

RATINGS

Limiting values in accordance with the Absolute Maximum System (IEC 134)

Collector-base voltage (open emitter)	$-V_{CB0}$	max.	30 V
Collector-emitter voltage (open base)	$-V_{CE0}$	max.	30 V
Emitter-base voltage (open collector)	$-V_{EB0}$	max.	4 V
Collector current (d.c.)	$-I_C$	max.	25 mA
Total power dissipation up to $T_{amb} = 25\text{ }^\circ\text{C}^*$	P_{tot}	max.	300 mW
Storage temperature	T_{stg}		-55 to $+150\text{ }^\circ\text{C}$
Junction temperature	T_j	max.	150 $^\circ\text{C}$

THERMAL RESISTANCE

From junction to ambient in free air*	$R_{th\ j-a}$	=	430 K/W
---------------------------------------	---------------	---	---------

CHARACTERISTICS

$T_j = 25\text{ }^\circ\text{C}$ unless otherwise specified

Collector cut-off current

$I_E = 0; -V_{CB} = 30\text{ V}$	$-I_{CBO}$	<	50 nA
----------------------------------	------------	---	-------

Emitter cut-off current

$I_C = 0; -V_{EB} = 4\text{ V}$	$-I_{EBO}$	<	10 μA
---------------------------------	------------	---	------------------

Base current

$-I_C = 4\text{ mA}; -V_{CE} = 10\text{ V}$	$-I_B$	typ.	80 μA
		<	160 μA

$-I_C = 1\text{ mA}; -V_{CE} = 10\text{ V}$	$-I_B$	typ.	22 μA
---	--------	------	------------------

Base-emitter voltage

$-I_C = 4\text{ mA}; -V_{CE} = 10\text{ V}$	$-V_{BE}$	typ.	0,76 V
---	-----------	------	--------

Transition frequency at $f = 100\text{ MHz}$

$-I_C = 1\text{ mA}; -V_{CE} = 10\text{ V}$	f_T	typ.	350 MHz
---	-------	------	---------

$-I_C = 4\text{ mA}; -V_{CE} = 10\text{ V}$	f_T	typ.	450 MHz
---	-------	------	---------

$-I_C = 8\text{ mA}; -V_{CE} = 10\text{ V}$	f_T	typ.	440 MHz
---	-------	------	---------

Feedback capacitance at $f = 1\text{ MHz}$

$V_{EB} = 0; -V_{CB} = 10\text{ V}$	C_{rb}	typ.	0,1 pF
-------------------------------------	----------	------	--------

Noise factor at $f = 100\text{ MHz}$

$-I_C = 2\text{ mA}; -V_{CE} = 10\text{ V};$ $G_s = 16,7\text{ mS}$	F	typ.	3 dB
--	---	------	------

$-I_C = 5\text{ mA}; -V_{CE} = 10\text{ V};$ $G_s = 6,7\text{ mS}; -jB_s = 5\text{ mS}$	F	typ.	3,5 dB
--	---	------	--------

* Mounted on ceramic substrate of 8 mm x 10 mm x 0,7 mm.

y-parameters (common base) at $f = 100 \text{ MHz}$

$-I_C = 4 \text{ mA}; -V_{CB} = 10 \text{ V}$

Input conductance

Input capacitance

Transfer admittance

Phase angle of transfer admittance

Output conductance

Output capacitance

Feedback admittance

Phase angle of feedback admittance

g_{ib}	typ.	125 mS
C_{ib}	typ.	64 pF
$ Y_{fb} $	typ.	100 mS
φ_{fb}	typ.	147°
g_{ob}	typ.	40 μS
C_{ob}	typ.	1,25 pF
$ Y_{rb} $	typ.	220 μS
φ_{rb}	typ.	85°

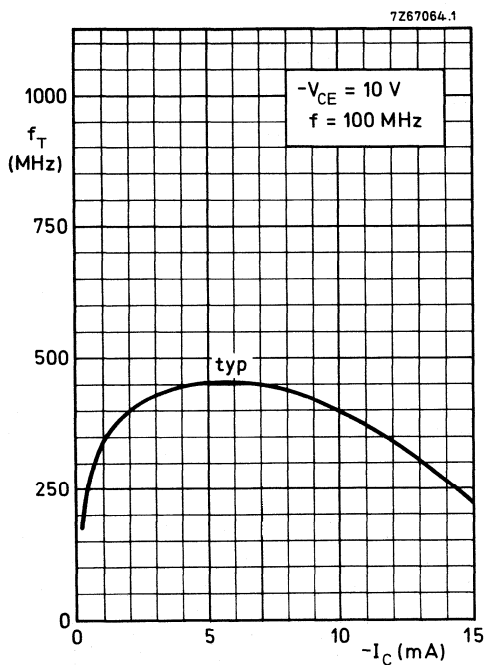

Fig. 2.

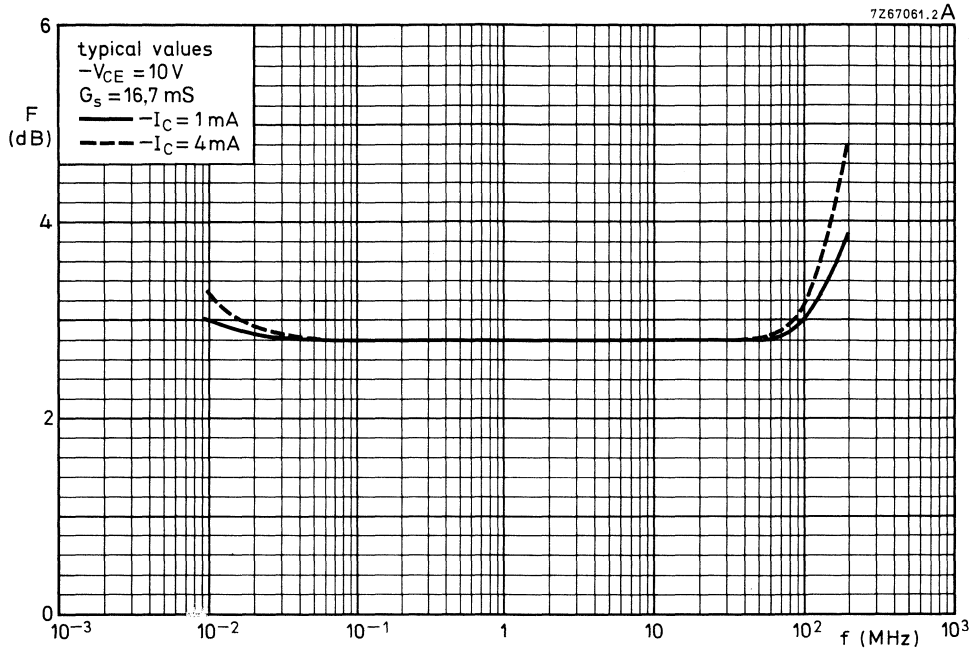

Fig. 3.

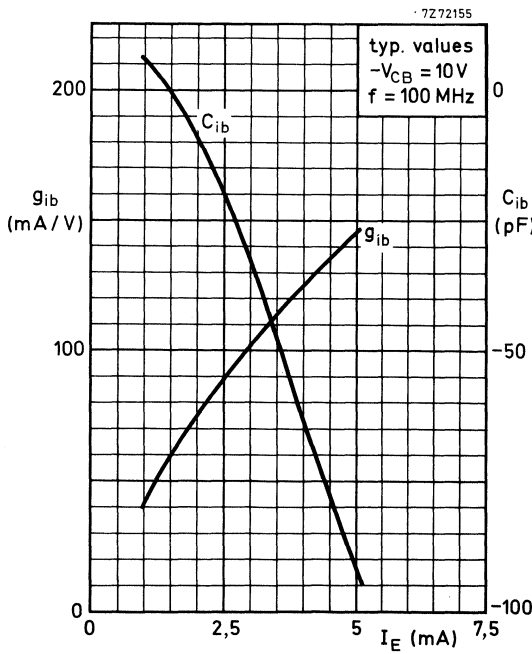

Fig. 4.

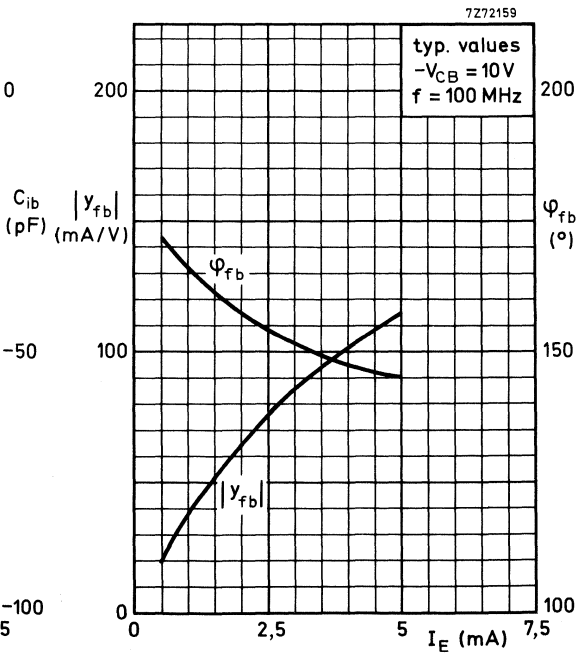

Fig. 5.

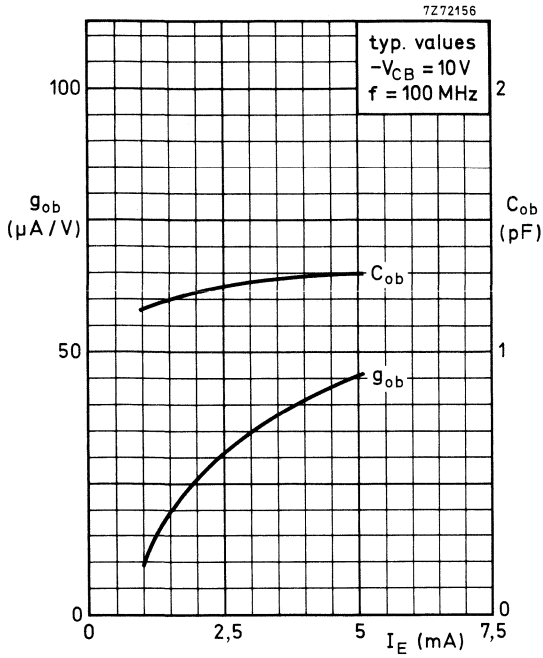

Fig. 6.

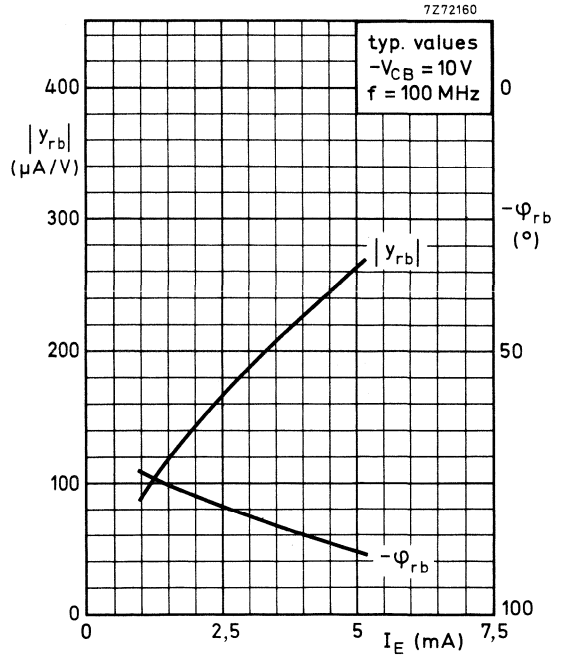

Fig. 7.

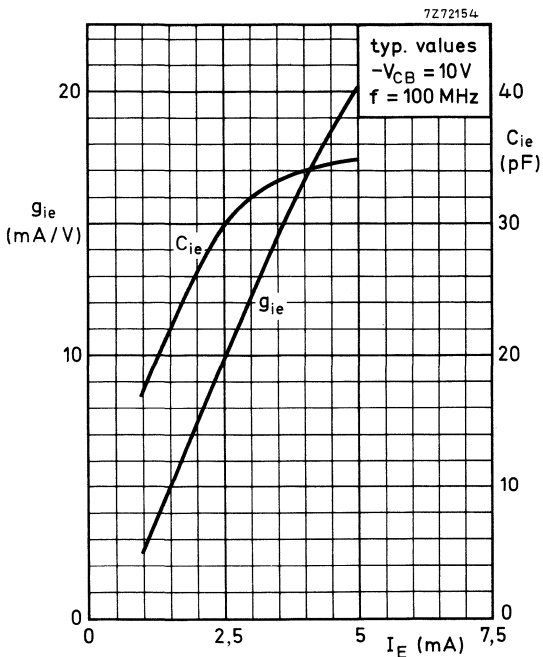

Fig. 8.

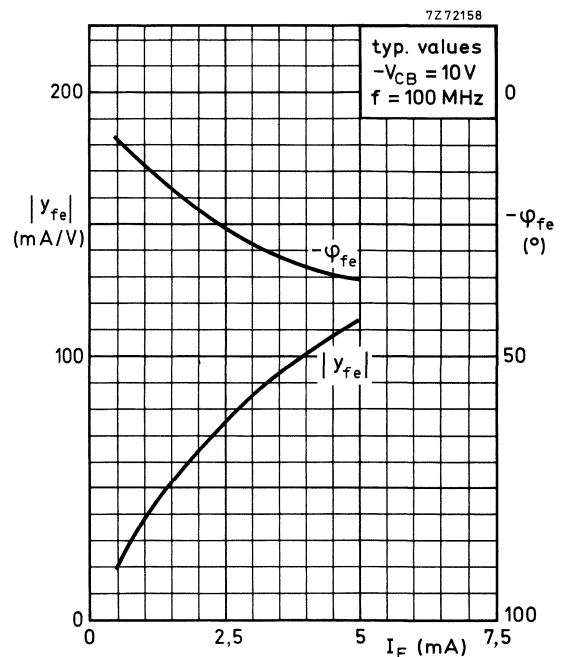

Fig. 9.

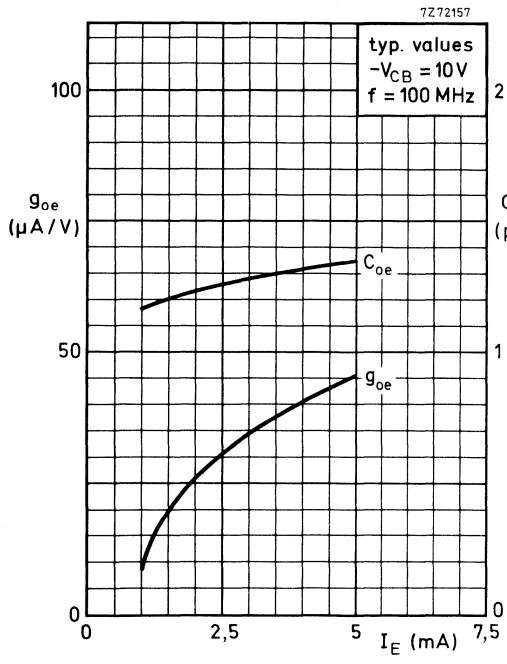

Fig. 10.

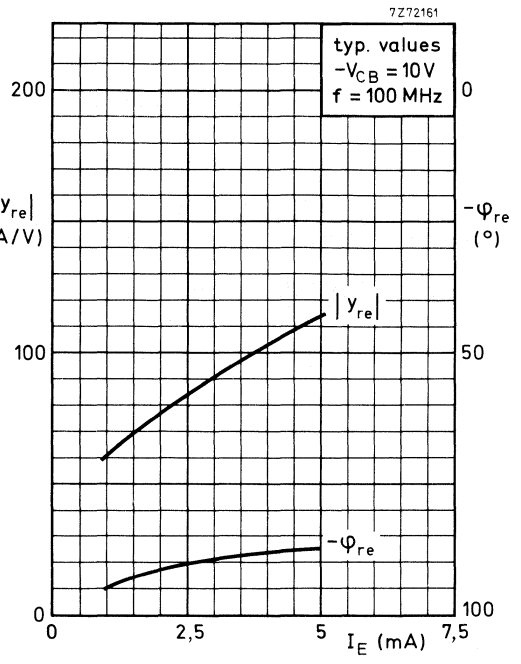

Fig. 11.

SILICON PLANAR TRANSISTORS

N-P-N transistors in a plastic SOT-23 envelope.

Primarily intended for a.m. mixers and i.f. amplifiers in a.m./f.m. receivers using SMD technology.

QUICK REFERENCE DATA

	BF840 BF841		
Collector-base voltage (open emitter)	V_{CBO}	max.	40 V
Collector-emitter voltage (open base)	V_{CE0}	max.	40 V
Collector current (d.c.)	I_C	max.	25 mA
Base current	I_B		4,5–15 8–28 μA
$I_C = 1 \text{ mA}; V_{CE} = 10 \text{ V}$			
Total power dissipation up to $T_{amb} = 25 \text{ }^\circ C$	P_{tot}	max.	300 mW
Junction temperature	T_j	max.	150 $^\circ C$
Feedback capacitance at $f = 1 \text{ MHz}$	C_{re}	typ.	0,3 pF
$I_C = 1 \text{ mA}; V_{CE} = 10 \text{ V}$			

MECHANICAL DATA

Fig. 1 SOT-23.

Dimensions in mm

Marking code:

BF840 : F3

BF841 : F31

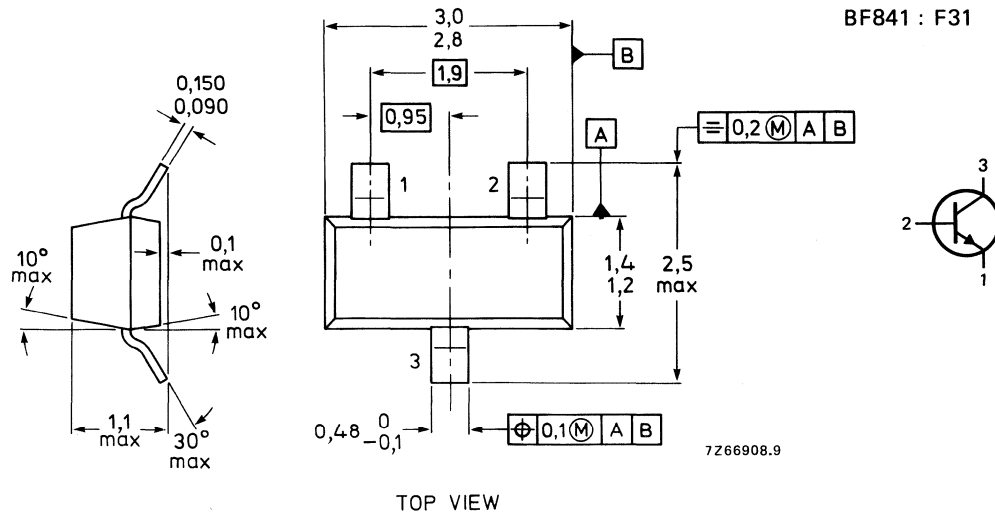

See also Soldering recommendations.

RATINGS

Limiting values in accordance with the Absolute Maximum System (IEC 134)

Collector-base voltage (open emitter)	V_{CBO}	max.	40 V
Collector-emitter voltage (open base)	V_{CEO}	max.	40 V
Emitter-base voltage (open collector)	V_{EBO}	max.	4 V
Collector current (d.c.)	I_C	max.	25 mA
Total power dissipation up to $T_{amb} = 25\text{ }^\circ\text{C}^*$	P_{tot}	max.	300 mW
Storage temperature	T_{stg}		-55 to +150 $^\circ\text{C}$
Junction temperature	T_j	max.	150 $^\circ\text{C}$

THERMAL RESISTANCE

From junction to ambient*	$R_{th\ j-a}$	=	430 K/W
---------------------------	---------------	---	---------

CHARACTERISTICS

$T_j = 25\text{ }^\circ\text{C}$ unless otherwise specified

Collector cut-off current

$I_E = 0; V_{CB} = 20\text{ V}$	I_{CBO}	max.	100 nA
---------------------------------	-----------	------	--------

Base-emitter voltage

$I_C = 1\text{ mA}; V_{CE} = 10\text{ V}$	V_{BE}	typ.	700 mV 650 to 740 mV
---	----------	------	-------------------------

Base current

$I_C = 1\text{ mA}; V_{CE} = 10\text{ V}$	I_B	4,5–15	8–28 μA
---	-------	--------	--------------------

Transition frequency at $f = 100\text{ MHz}$

$I_C = 1\text{ mA}; V_{CE} = 10\text{ V}$	f_T	typ.	380	380 MHz
---	-------	------	-----	---------

Feedback capacitance at $f = 1\text{ MHz}$

$I_C = 1\text{ mA}; V_{CE} = 10\text{ V}$	C_{re}	typ.	0,3	0,3 pF
---	----------	------	-----	--------

Noise figure

$I_C = 1\text{ mA}; V_{CE} = 10\text{ V};$ $f = 0,2\text{ MHz}; R_S = 200\ \Omega$	F	typ.	1,5	2,0 dB
---	-----	------	-----	--------

* Mounted on a ceramic substrate of 8 mm x 10 mm x 0,7 mm.

SILICON N-CHANNEL DUAL GATE MOS-FET

Depletion type field-effect transistor in a plastic SOT-143 microminiature envelope with source and substrate interconnected. This MOS-FET tetrode is intended for use in u.h.f. applications in television tuners. The device is also suitable for use in professional communication equipment.

The device is protected against excessive input voltage surges by integrated back-to-back diodes between gates and source.

QUICK REFERENCE DATA

Drain-source voltage	V_{DS}	max.	20 V
Drain current (peak value)	I_{DM}	max.	30 mA
Total power dissipation up to $T_{amb} = 60\text{ }^{\circ}\text{C}$	P_{tot}	max.	200 mW
Junction temperature	T_j	max.	150 $^{\circ}\text{C}$
Transfer admittance at $f = 1\text{ kHz}$ $I_D = 7\text{ mA}$; $V_{DS} = 10\text{ V}$; $+V_{G2-S} = 4\text{ V}$	$ Y_{fs} $	typ.	12 mS
Feedback capacitance at $f = 1\text{ MHz}$ $I_D = 7\text{ mA}$; $V_{DS} = 10\text{ V}$; $+V_{G2-S} = 4\text{ V}$	C_{rs}	typ.	25 fF
Noise figure at $G_S = 2\text{ mS}$ $I_D = 7\text{ mA}$; $V_{DS} = 10\text{ V}$; $+V_{G2-S} = 4\text{ V}$; $f = 800\text{ MHz}$	F	typ.	2,8 dB

MECHANICAL DATA

Fig. 1 SOT-143.

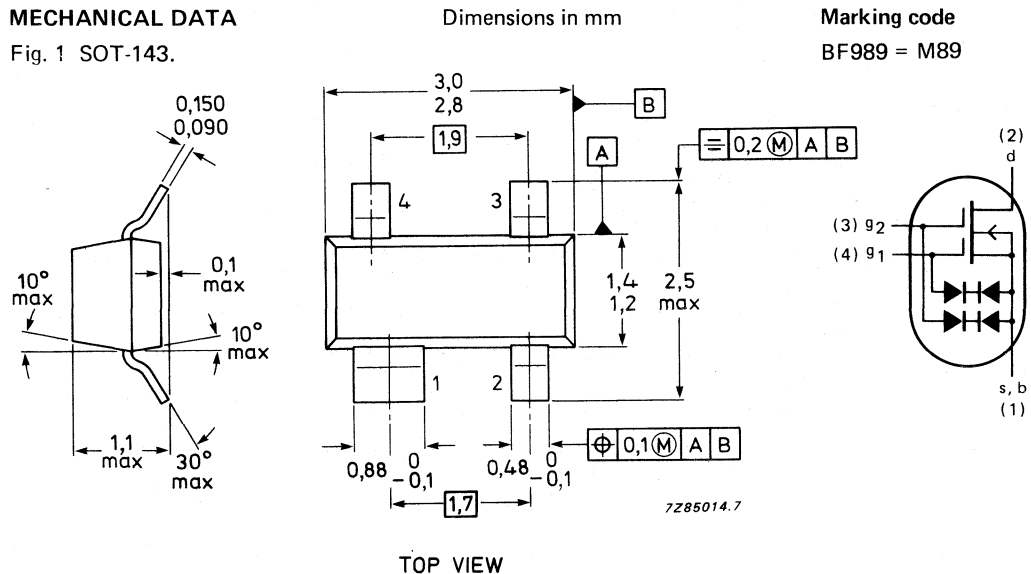

See also *Soldering recommendations*.

RATINGS

Limiting values in accordance with the Absolute Maximum System (IEC 134)

Drain-source voltage	V_{DS}	max.	20 V
Drain current (d.c. or average)	I_D	max.	20 mA
Drain current (peak value)	I_{DM}	max.	30 mA
Gate 1 - source current	$\pm I_{G1-S}$	max.	10 mA
Gate 2 - source current	$\pm I_{G2-S}$	max.	10 mA
Total power dissipation up to $T_{amb} = 60\text{ }^\circ\text{C}^*$	P_{tot}	max.	200 mW
Storage temperature	T_{stg}		-65 to + 150 $^\circ\text{C}$
Junction temperature	T_j	max.	150 $^\circ\text{C}$

THERMAL RESISTANCE

From junction to ambient in free air*	$R_{th\ j-a}$	=	460 K/W
---------------------------------------	---------------	---	---------

STATIC CHARACTERISTICS $T_{amb} = 25\text{ }^\circ\text{C}$ unless otherwise specified

Gate cut-off currents

$\pm V_{G1-S} = 5\text{ V}; V_{G2-S} = V_{DS} = 0$	$\pm I_{G1-SS}$	<	50 nA
$\pm V_{G2-S} = 5\text{ V}; V_{G1-S} = V_{DS} = 0$	$\pm I_{G2-SS}$	<	50 nA

Drain current

$V_{DS} = 10\text{ V}; V_{G1-S} = 0; + V_{G2-S} = 4\text{ V}; T_j = 25\text{ }^\circ\text{C}$	I_{DSS}		2 to 20 mA
---	-----------	--	------------

Gate-source breakdown voltages

$\pm I_{G1-SS} = 10\text{ mA}; V_{G2-S} = V_{DS} = 0$	$\pm V_{(BR)G1-SS}$		6 to 20 V
$\pm I_{G2-SS} = 10\text{ mA}; V_{G1-S} = V_{DS} = 0$	$\pm V_{(BR)G2-SS}$		6 to 20 V

Gate-source cut-off voltages

$I_D = 20\text{ }\mu\text{A}; V_{DS} = 10\text{ V}; + V_{G2-S} = 4\text{ V}$	$-V_{(P)G1-S}$	<	2,7 V
$I_D = 20\text{ }\mu\text{A}; V_{DS} = 10\text{ V}; V_{G1-S} = 0$	$-V_{(P)G2-S}$	<	2,7 V

DYNAMIC CHARACTERISTICSMeasuring conditions (common source): $I_D = 7\text{ mA}; V_{DS} = 10\text{ V}; + V_{G2-S} = 4\text{ V}; T_{amb} = 25\text{ }^\circ\text{C}$

Transfer admittance at $f = 1\text{ kHz}$	$ Y_{fs} $	>	9,5 mS
		typ.	12 mS
Input capacitance at gate 1; $f = 1\text{ MHz}$	C_{ig1-s}	typ.	1,8 pF
Input capacitance at gate 2; $f = 1\text{ MHz}$	C_{ig2-s}	typ.	1,0 pF
Feedback capacitance at $f = 1\text{ MHz}$	C_{rs}	typ.	25 fF
Output capacitance at $f = 1\text{ MHz}$	C_{os}	typ.	0,9 pF
Noise figure at $G_S = 2\text{ mS}$			
$f = 200\text{ MHz}$	F	typ.	1,6 dB
$f = 800\text{ MHz}$	F	typ.	2,8 dB

* Device mounted on a ceramic substrate of 8 mm x 10 mm x 0,7 mm.

SILICON N-CHANNEL DUAL GATE MOS-FET

Depletion type field-effect transistor in a plastic microminiature envelope with source and substrate interconnected, intended for u.h.f. applications, such as u.h.f. television tuners and professional communication equipment.

This MOS-FET tetrode is protected against excessive input voltage surges by integrated back-to-back diodes between gates and source.

QUICK REFERENCE DATA

Drain-source voltage	V_{DS}	max.	18 V
Drain current (average)	$I_{D(AV)}$	max.	30 mA
Total power dissipation up to $T_{amb} = 60\text{ }^{\circ}\text{C}$	P_{tot}	max.	200 mW
Junction temperature	T_j	max.	150 $^{\circ}\text{C}$
Transfer admittance at $f = 1\text{ kHz}$ $I_D = 10\text{ mA}; V_{DS} = 10\text{ V}; +V_{G2-S} = 4\text{ V}$	$ y_{fs} $	typ.	19 mS
Feedback capacitance at $f = 1\text{ MHz}$ $I_D = 10\text{ mA}; V_{DS} = 10\text{ V}; +V_{G2-S} = 4\text{ V}$	C_{rs}	typ.	25 fF
Noise figure at optimum source admittance $I_D = 10\text{ mA}; V_{DS} = 10\text{ V}; +V_{G2-S} = 4\text{ V}; f = 800\text{ MHz}$	F	typ.	2,8 dB

MECHANICAL DATA

Fig. 1 SOT-143.

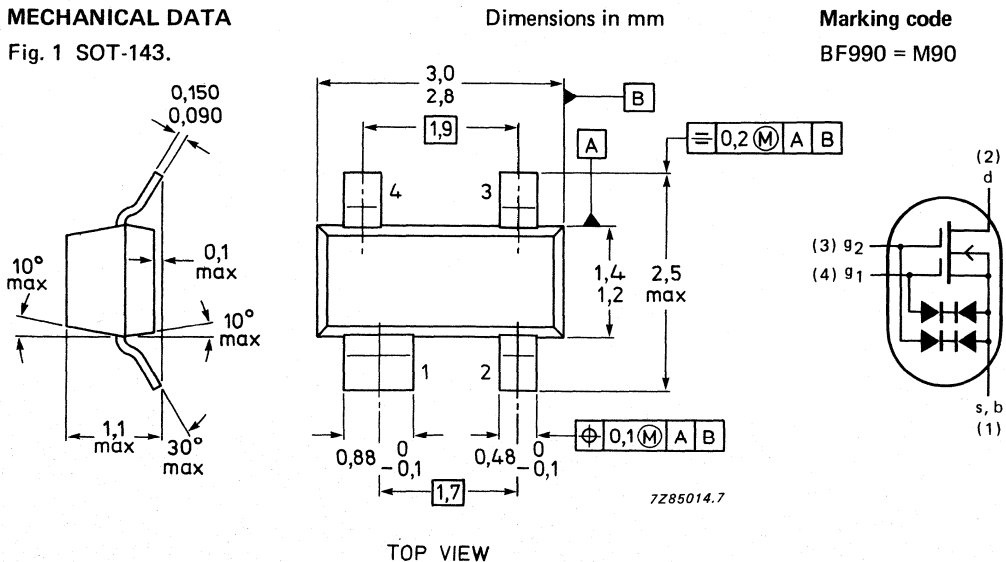

See also *Soldering recommendations*.

RATINGS

Limiting values in accordance with the Absolute Maximum System (IEC 134)

Drain-source voltage	V_{DS}	max.	18 V
Drain current (average)	$I_{D(AV)}$	max.	30 mA
Gate 1-source current	$\pm I_{G1-S}$	max.	10 mA
Gate 2-source current	$\pm I_{G2-S}$	max.	10 mA
Total power dissipation up to $T_{amb} = 60\text{ }^{\circ}\text{C}^*$	P_{tot}	max.	200 mW
Storage temperature	T_{stg}		-65 to + 150 $^{\circ}\text{C}$
Junction temperature	T_j	max.	150 $^{\circ}\text{C}$

THERMAL RESISTANCE

From junction to ambient in free air* $R_{thj-a} = 460\text{ K/W}$

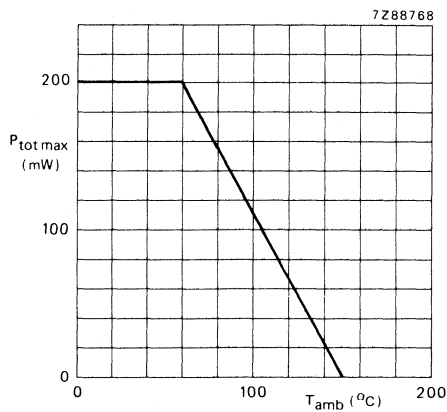

Fig. 2 Power derating curve.

* Device mounted on a ceramic substrate of 8 mm x 10 mm x 0,7 mm.

STATIC CHARACTERISTICS $T_{amb} = 25\text{ }^{\circ}\text{C}$ unless otherwise specified

Gate cut-off currents

gate 1; $\pm V_{G1-S} = 7\text{ V}; V_{G2-S} = V_{DS} = 0$	$\pm I_{G1-SS}$	<	25 nA
---	-----------------	---	-------

gate 2; $\pm V_{G2-S} = 7\text{ V}; V_{G1-S} = V_{DS} = 0$	$\pm I_{G2-SS}$	<	25 nA
---	-----------------	---	-------

Gate-source breakdown voltages

gate 1; $\pm I_{G1-SS} = 10\text{ mA}; V_{G2-S} = V_{DS} = 0$	$\pm V_{(BR)G1-SS}$	>	8 V
--	---------------------	---	-----

gate 2; $\pm I_{G2-SS} = 10\text{ mA}; V_{G1-S} = V_{DS} = 0$	$\pm V_{(BR)G2-SS}$	>	8 V
--	---------------------	---	-----

Gate-source cut-off voltages

gate 1; $I_D = 20\text{ }\mu\text{A}; V_{DS} = 10\text{ V}; +V_{G2-S} = 4\text{ V}$	$-V_{(P)G1-S}$	<	1,3 V
--	----------------	---	-------

gate 2; $I_D = 20\text{ }\mu\text{A}; V_{DS} = 10\text{ V}; V_{G1-S} = 0$	$-V_{(P)G2-S}$	<	1,1 V
--	----------------	---	-------

DYNAMIC CHARACTERISTICSMeasuring conditions (common source): $I_D = 10\text{ mA}; V_{DS} = 10\text{ V}; +V_{G2-S} = 4\text{ V}; T_{amb} = 25\text{ }^{\circ}\text{C}$

Transfer admittance at $f = 1\text{ kHz}$	$ y_{fs} $	>	17 mS
		typ.	19 mS
		typ.	2,6 pF

Input capacitance at gate 1; $f = 1\text{ MHz}$	C_{ig1-s}	<	3,0 pF
---	-------------	---	--------

Input capacitance at gate 2; $f = 1\text{ MHz}$	C_{ig2-s}	typ.	1,4 pF
---	-------------	------	--------

Feedback capacitance at $f = 1\text{ MHz}$	C_{rs}	typ.	25 fF
--	----------	------	-------

Output capacitance at $f = 1\text{ MHz}$	C_{os}	typ.	1,2 pF
--	----------	------	--------

Noise figure at $f = 800\text{ MHz}; G_S = 5\text{ mS}$	F	typ.	2,8 dB
---	---	------	--------

SILICON N-CHANNEL DUAL GATE MOS-FET

Depletion type field-effect transistor in a plastic SOT-143 microminiature envelope with source and substrate interconnected. This MOS-FET tetrode is intended for use in v.h.f. applications, such as v.h.f. television tuners and f.m. tuners. The device is also suitable for use in professional communication equipment.

The device is protected against excessive input voltage surges by integrated back-to-back diodes between gates and source.

QUICK REFERENCE DATA

Drain-source voltage	V_{DS}	max.	20 V
Drain current	I_D	max.	20 mA
Total power dissipation up to $T_{amb} = 60\text{ }^\circ\text{C}$	P_{tot}	max.	200 mW
Junction temperature	T_j	max.	150 $^\circ\text{C}$
Transfer admittance at $f = 1\text{ kHz}$ $I_D = 10\text{ mA}; V_{DS} = 10\text{ V}; +V_{G2-S} = 4\text{ V}$	$ Y_{fs} $	typ.	14 mS
Feedback capacitance at $f = 1\text{ MHz}$ $I_D = 10\text{ mA}; V_{DS} = 10\text{ V}; +V_{G2-S} = 4\text{ V}$	C_{rs}	typ.	20 fF
Noise figure at optimum source admittance $I_D = 10\text{ mA}; V_{DS} = 10\text{ V}; +V_{G2-S} = 4\text{ V}; f = 200\text{ MHz}$	F	typ.	0,7 dB

MECHANICAL DATA

Fig. 1 SOT-143.

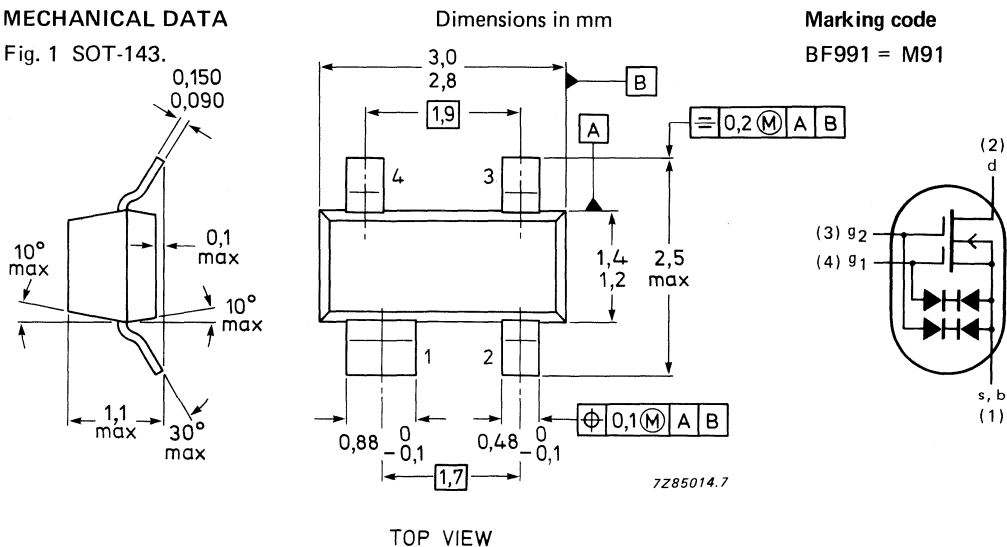

See also *Soldering recommendations*.

RATINGS

Limiting values in accordance with the Absolute Maximum System (IEC 134)

Drain-source voltage	V_{DS}	max.	20 V
Drain current (d.c. or average)	I_D	max.	20 mA
Drain current (peak value)	I_{DM}	max.	30 mA
Gate 1 - source current	$\pm I_{G1-S}$	max.	10 mA
Gate 2 - source current	$\pm I_{G2-S}$	max.	10 mA
Total power dissipation up to $T_{amb} = 60\text{ }^\circ\text{C}^*$	P_{tot}	max.	200 mW
Storage temperature	T_{stg}		-65 to + 150 $^\circ\text{C}$
Junction temperature	T_j	max.	150 $^\circ\text{C}$

THERMAL RESISTANCE

From junction to ambient in free air*	$R_{th\ j-a}$	=	460 K/W
---------------------------------------	---------------	---	---------

STATIC CHARACTERISTICS

$T_{amb} = 25\text{ }^\circ\text{C}$ unless otherwise specified

Gate cut-off currents

$\pm V_{G1-S} = 5\text{ V}; V_{G2-S} = V_{DS} = 0$	$\pm I_{G1-SS}$	<	50 nA
$\pm V_{G2-S} = 5\text{ V}; V_{G1-S} = V_{DS} = 0$	$\pm I_{G2-SS}$	<	50 nA

Drain current

$V_{DS} = 10\text{ V}; V_{G1-S} = 0; +V_{G2-S} = 4\text{ V}; T_j = 25\text{ }^\circ\text{C}$	I_{DSS}		4 to 25 mA
--	-----------	--	------------

Gate-source breakdown voltages

$\pm I_{G1-SS} = 10\text{ mA}; V_{G2-S} = V_{DS} = 0$	$\pm V_{(BR)G1-SS}$	>	6 V
$\pm I_{G2-SS} = 10\text{ mA}; V_{G1-S} = V_{DS} = 0$	$\pm V_{(BR)G2-SS}$	>	6 V

Gate-source cut-off voltages

$I_D = 20\text{ }\mu\text{A}; V_{DS} = 10\text{ V}; +V_{G2-S} = 4\text{ V}$	$-V_{(P)G1-S}$	<	2,5 V
$I_D = 20\text{ }\mu\text{A}; V_{DS} = 10\text{ V}; V_{G1-S} = 0$	$-V_{(P)G2-S}$	<	2,5 V

DYNAMIC CHARACTERISTICS

Measuring conditions (common source): $I_D = 10\text{ mA}; V_{DS} = 10\text{ V}; +V_{G2-S} = 4\text{ V}; T_{amb} = 25\text{ }^\circ\text{C}$

Transfer admittance at $f = 1\text{ kHz}$	$ Y_{fs} $	>	10 mS
		typ.	14 mS
Input capacitance at gate 1; $f = 1\text{ MHz}$	C_{ig1-s}	typ.	2,1 pF
Input capacitance at gate 2; $f = 1\text{ MHz}$	C_{ig2-s}	typ.	1,0 pF
Feedback capacitance at $f = 1\text{ MHz}$	C_{rs}	typ.	20 fF
Output capacitance at $f = 1\text{ MHz}$	C_{os}	typ.	1,1 pF
Noise figure			
$f = 100\text{ MHz}; G_S = 1\text{ mS}$	F	typ.	0,7 dB
		<	1,7 dB
$f = 200\text{ MHz}; G_S = 2\text{ mS}$	F	typ.	1,0 dB
		<	2,0 dB
Transducer gain **			
$f = 100\text{ MHz}; G_S = 1\text{ mS}; G_L = 0,5\text{ mS}$	G_{tr}	typ.	29 dB
$f = 200\text{ MHz}; G_S = 2\text{ mS}; G_L = 0,5\text{ mS}$	G_{tr}	typ.	26 dB

* Device mounted on a ceramic substrate of 8 mm x 10 mm x 0,7 mm.

** Crystal mounted in a SOT-103 envelope.

SILICON N-CHANNEL DUAL GATE MOS-FET

Depletion type field-effect transistor in a plastic SOT-143 microminiature envelope with source and substrate interconnected. This MOS-FET tetrode is intended for use in v.h.f. applications, such as v.h.f. television tuners, FM tuners with a 12 volt supply voltage. The device is also suitable for use in professional communication equipment.

The device is protected against excessive input voltage surges by integrated back-to-back diodes between gates and source.

QUICK REFERENCE DATA

Drain-source voltage	V_{DS}	max.	20 V
Drain current	I_D	max.	40 mA
Total power dissipation up to $T_{amb} = 60\text{ }^\circ\text{C}$	P_{tot}	max.	200 mW
Junction temperature	T_j	max.	150 $^\circ\text{C}$
Transfer admittance at $f = 1\text{ kHz}$ $I_D = 15\text{ mA}; V_{DS} = 10\text{ V}; +V_{G2-S} = 4\text{ V}$	$ Y_{fs} $	typ.	25 mS
Feedback capacitance at $f = 1\text{ MHz}$ $I_D = 15\text{ mA}; V_{DS} = 10\text{ V}; +V_{G2-S} = 4\text{ V}$	C_{rs}	typ.	30 fF
Noise figure at $G_S = 2\text{ mS}$ $I_D = 15\text{ mA}; V_{DS} = 10\text{ V}; +V_{G2-S} = 4\text{ V}; f = 200\text{ MHz}$	F	typ.	1,2 dB

MECHANICAL DATA

Fig. 1 SOT-143.

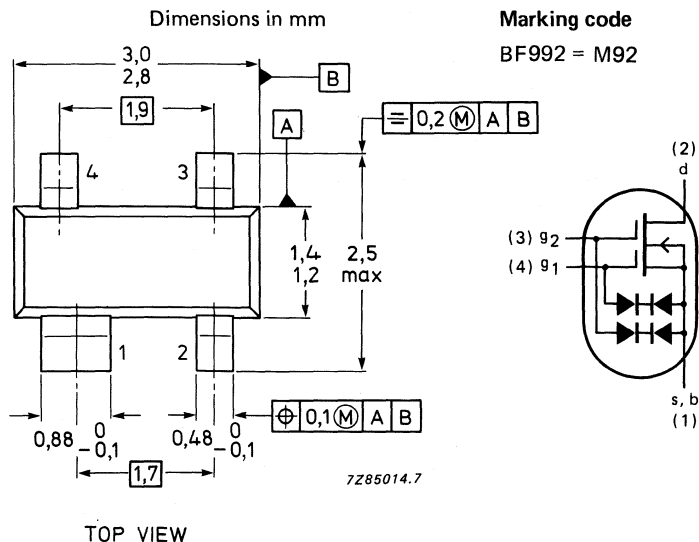
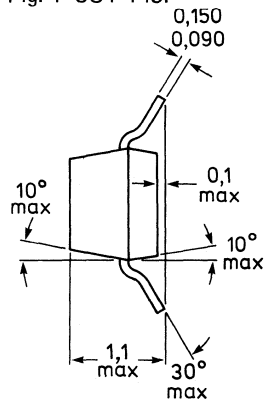

See also *Soldering recommendations.*

RATINGS

Limiting values in accordance with the Absolute Maximum System (IEC 134)

Drain-source voltage	V_{DS}	max.	20 V
Drain current (d.c. or average)	I_D	max.	40 mA
Gate 1 - source current	$\pm I_{G1-S}$	max.	10 mA
Gate 2 - source current	$\pm I_{G2-S}$	max.	10 mA
Total power dissipation up to $T_{amb} = 60\text{ }^\circ\text{C}^*$	P_{tot}	max.	200 mW
Storage temperature	T_{stg}		-65 to $+150\text{ }^\circ\text{C}$
Junction temperature	T_j	max.	150 $^\circ\text{C}$

THERMAL RESISTANCE

From junction to ambient in free air*	R_{thj-a}	=	460 K/W
---------------------------------------	-------------	---	---------

STATIC CHARACTERISTICS $T_{amb} = 25\text{ }^\circ\text{C}$ unless otherwise specified

Gate cut-off currents

$\pm V_{G1-S} = 7\text{ V}; V_{G2-S} = V_{DS} = 0$	$\pm I_{G1-SS}$	<	25 nA
$\pm V_{G2-S} = 7\text{ V}; V_{G1-S} = V_{DS} = 0$	$\pm I_{G2-SS}$	<	25 nA

Gate-source breakdown voltages

$\pm I_{G1-SS} = 10\text{ mA}; V_{G2-S} = V_{DS} = 0$	$\pm V_{(BR)G1-SS}$	>	8 V
$\pm I_{G2-SS} = 10\text{ mA}; V_{G1-S} = V_{DS} = 0$	$\pm V_{(BR)G2-SS}$	>	8 V

Gate-source cut-off voltages

$I_D = 20\text{ }\mu\text{A}; V_{DS} = 10\text{ V}; +V_{G2-S} = 4\text{ V}$	$-V_{(P)G1-S}$		0,2 to 1,3 V
$I_D = 20\text{ }\mu\text{A}; V_{DS} = 10\text{ V}; V_{G1-S} = 0$	$-V_{(P)G2-S}$		0,2 to 1,1 V

DYNAMIC CHARACTERISTICSMeasuring conditions (common source): $I_D = 15\text{ mA}; V_{DS} = 10\text{ V}; +V_{G2-S} = 4\text{ V}; T_{amb} = 25\text{ }^\circ\text{C}$

Transfer admittance at $f = 1\text{ kHz}$	$ Y_{fs} $	>	20 mS
		typ.	25 mS
Input capacitance at gate 1; $f = 1\text{ MHz}$	C_{ig1-s}	typ.	4 pF
Input capacitance at gate 2; $f = 1\text{ MHz}$	C_{ig2-s}	typ.	1,7 pF
Feedback capacitance at $f = 1\text{ MHz}$	C_{rs}	typ.	30 fF
		<	40 fF
Output capacitance at $f = 1\text{ MHz}$	C_{os}	typ.	2 pF
Noise figure at $f = 200\text{ MHz}; G_S = 2\text{ mS}$	F	typ.	1,2 dB

→ * Device mounted on a ceramic substrate of 8 mm x 10 mm x 0,7 mm.

SILICON N-CHANNEL DUAL GATE MOS-FET

Depletion type field-effect transistor in a plastic microminiature envelope with source and substrate interconnected, intended for u.h.f. and v.h.f. applications, such as u.h.f./v.h.f. television tuners and professional communication equipment.

This MOS-FET tetrode is protected against excessive input voltage surges by integrated back-to-back diodes between gates and source.

QUICK REFERENCE DATA

Drain-source voltage	V_{DS}	max.	20 V
Drain current (average)	$I_{D(AV)}$	max.	30 mA
Total power dissipation up to $T_{amb} = 60\text{ }^{\circ}\text{C}$	P_{tot}	max.	200 mW
Junction temperature	T_j	max.	150 $^{\circ}\text{C}$
Transfer admittance at $f = 1\text{ kHz}$ $I_D = 10\text{ mA}; V_{DS} = 15\text{ V}; +V_{G2-S} = 4\text{ V}$	$ y_{fs} $	typ.	17 mS
Feedback capacitance at $f = 1\text{ MHz}$ $I_D = 10\text{ mA}; V_{DS} = 15\text{ V}; +V_{G2-S} = 4\text{ V}$	C_{rs}	typ.	25 fF
Noise figure at optimum source admittance $I_D = 10\text{ mA}; V_{DS} = 15\text{ V}; +V_{G2-S} = 4\text{ V}; f = 200\text{ MHz}$	F	typ.	1,5 dB

MECHANICAL DATA

Fig. 1 SOT-143.

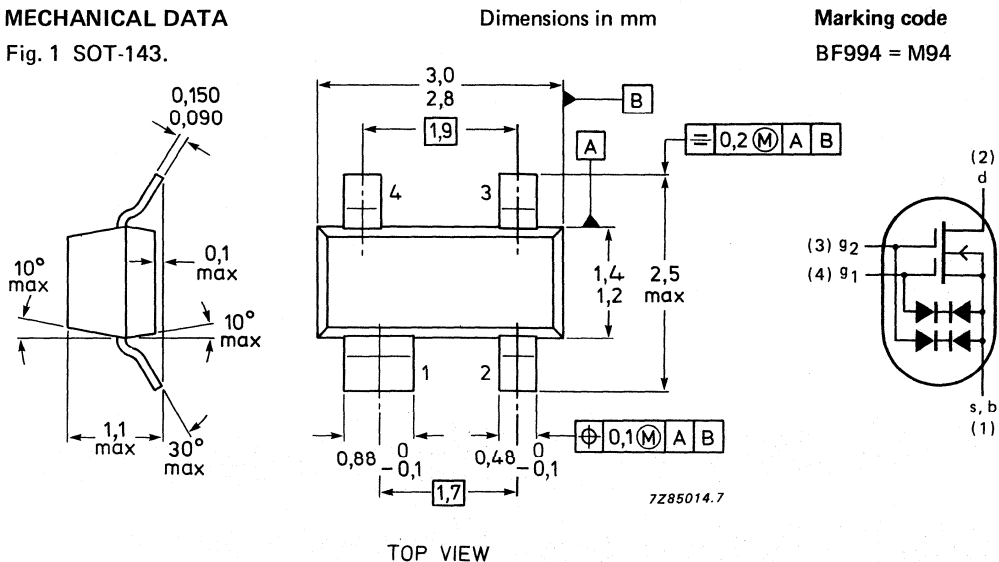

See also *Soldering recommendations*.

RATINGS

Limiting values in accordance with the Absolute Maximum System (IEC 134)

Drain-source voltage	V_{DS}	max.	20 V
Drain current (average)	$I_{D(AV)}$	max.	30 mA
Gate 1-source current	$\pm I_{G1-S}$	max.	10 mA
Gate 2-source current	$\pm I_{G2-S}$	max.	10 mA
Total power dissipation up to $T_{amb} = 60\text{ }^{\circ}\text{C}^*$	P_{tot}	max.	200 mW
Storage temperature	T_{stg}		-65 to + 150 $^{\circ}\text{C}$
Junction temperature	T_j	max.	150 $^{\circ}\text{C}$

THERMAL RESISTANCE

From junction to ambient in free air* $R_{thj-a} = 460\text{ K/W}$

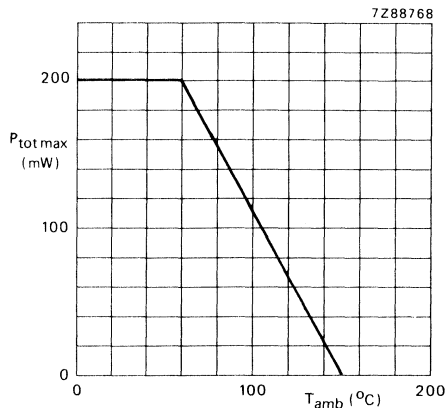

Fig. 2 Power derating curve.

* Device mounted on a ceramic substrate of 8 mm x 10 mm x 0,6 mm.

STATIC CHARACTERISTICS $T_{amb} = 25\text{ }^{\circ}\text{C}$ unless otherwise specified

Gate cut-off currents

gate 1;

 $\pm V_{G1-S} = 5\text{ V}; V_{G2-S} = V_{DS} = 0$ $\pm I_{G1-SS} < 50\text{ nA}$

gate 2;

 $\pm V_{G2-S} = 5\text{ V}; V_{G1-S} = V_{DS} = 0$ $\pm I_{G2-SS} < 50\text{ nA}$

Gate-source breakdown voltages

gate 1;

 $\pm I_{G1-SS} = 10\text{ mA}; V_{G2-S} = V_{DS} = 0$ $\pm V_{(BR)G1-SS} 6\text{ to }20\text{ V}$

gate 2;

 $\pm I_{G2-SS} = 10\text{ mA}; V_{G1-S} = V_{DS} = 0$ $\pm V_{(BR)G2-SS} 6\text{ to }20\text{ V}$

Gate-source cut-off voltages

gate 1;

 $I_D = 20\text{ }\mu\text{A}; V_{DS} = 15\text{ V}; +V_{G2-S} = 4\text{ V}$ $-V_{(P)G1-S} < 2,5\text{ V}$

gate 2;

 $I_D = 20\text{ }\mu\text{A}; V_{DS} = 15\text{ V}; V_{G1-S} = 0$ $-V_{(P)G2-S} < 2,0\text{ V}$

Drain-source cut-off voltage

 $V_{DS} = 15\text{ V}; V_{G2-S} = 4\text{ V}$ $I_{DSS} 2\text{ to }20\text{ mA}$ **DYNAMIC CHARACTERISTICS**Measuring conditions (common source): $I_D = 10\text{ mA}; V_{DS} = 15\text{ V}; +V_{G2-S} = 4\text{ V}; T_{amb} = 25\text{ }^{\circ}\text{C}$ Transfer admittance at $f = 1\text{ kHz}$ $|Y_{fs}| > 15\text{ mS}$
typ. 17 mSInput capacitance at gate 1; $f = 1\text{ MHz}$ C_{ig1-s} typ. 2,5 pFInput capacitance at gate 2; $f = 1\text{ MHz}$ C_{ig2-s} typ. 1,2 pFFeedback capacitance at $f = 1\text{ MHz}$ C_{rs} typ. 25 fFOutput capacitance at $f = 1\text{ MHz}$ C_{os} typ. 1,0 pFNoise figure at $f = 200\text{ MHz}; G_S = 2\text{ mS}$ F typ. 1,5 dB
< 2,8 dBPower gain at $G_S = 2\text{ mS}$ G_p typ. 25 dB
 $G_L = 0,5\text{ mS}, f = 200\text{ MHz}$

SILICON N-CHANNEL DUAL GATE MOS-FET

Depletion type field-effect transistor in a plastic microminiature envelope (SOT-143) with source and substrate interconnected and intended for v.h.f. applications in television tuners, using SMD* technology. The device is also suitable for use in professional communication equipment.

This MOS FET tetrode is protected against excessive input voltage surges by integrated back-to-back diodes between gates and source.

* Surface Mounted Devices.

QUICK REFERENCE DATA

Drain-source voltage	V_{DS}	max.	20 V
Drain current	I_D	max.	50 mA
Total power dissipation up to $T_{amb} = 25\text{ }^\circ\text{C}$	P_{tot}	max.	300 mW
Junction temperature	T_j	max.	150 $^\circ\text{C}$
Transfer admittance at $f = 1\text{ kHz}$ $I_D = 10\text{ mA}$; $V_{DS} = 15\text{ V}$; $+V_{G2-S} = 4\text{ V}$	$ y_{fs} $	typ.	18 mS
Feedback capacitance at $f = 1\text{ MHz}$ $I_D = 10\text{ mA}$; $V_{DS} = 15\text{ V}$; $+V_{G2-S} = 4\text{ V}$	C_{rs}	typ.	25 fF
Noise figure at $G_S = 2\text{ mS}$ $I_D = 10\text{ mA}$; $V_{DS} = 15\text{ V}$; $+V_{G2-S} = 4\text{ V}$; $f = 200\text{ MHz}$	F	typ.	1,0 dB

MECHANICAL DATA

Fig. 1 SOT-143.

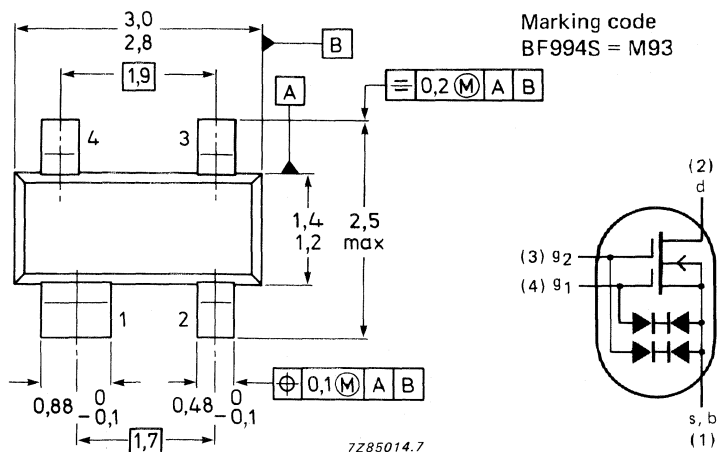
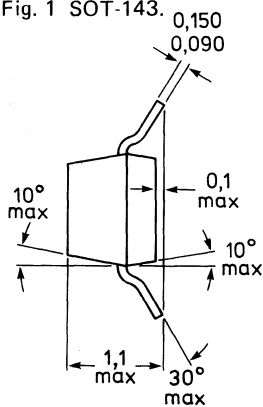

TOP VIEW

RATINGS

Limiting values in accordance with the Absolute Maximum System (IEC 134)

Drain-source voltage	V_{DS}	max.	20 V
Drain current (d.c. or average)	I_D	max.	50 mA
Gate 1 - source current	$\pm I_{G1-S}$	max.	10 mA
Gate 2 - source current	$\pm I_{G2-S}$	max.	10 mA
Total power dissipation up to $T_{amb} = 25\text{ }^\circ\text{C}$	P_{tot}	max.	300 mW
Storage temperature	T_{stg}		-65 to 150 $^\circ\text{C}$
Junction temperature	T_j	max.	150 $^\circ\text{C}$

THERMAL RESISTANCE

From junction to ambient in free air mounted on a ceramic substrate of 8 mm x 10 mm x 0,7 mm

$R_{th\ j-a}$	=	430 K/W
---------------	---	---------

STATIC CHARACTERISTICS

$T_j = 25\text{ }^\circ\text{C}$ unless otherwise specified

Gate cut-off currents

$\pm V_{G1-S} = 5\text{ V}; V_{G2-S} = V_{DS} = 0$
 $\pm V_{G2-S} = 5\text{ V}; V_{G1-S} = V_{DS} = 0$

$\pm I_{G1-S}$	<	50 nA
$\pm I_{G2-S}$	<	50 nA

Gate-source breakdown voltages

$\pm I_{G1-S} = 10\text{ mA}; V_{G2-S} = V_{DS} = 0$
 $\pm I_{G2-S} = 10\text{ mA}; V_{G1-S} = V_{DS} = 0$

$\pm V_{(BR)G1-SS}$	6,0 to 20 V
$\pm V_{(BR)G2-SS}$	6,0 to 20 V

Drain current

$V_{DS} = 15\text{ V}; V_{G1-S} = 0; V_{G2-S} = 4\text{ V}$

I_{DSS}	4 to 20 mA
-----------	------------

Gate-source cut-off voltages

$I_D = 20\text{ }\mu\text{A}; V_{DS} = 15\text{ V}; +V_{G2-S} = 4\text{ V}$
 $I_D = 20\text{ }\mu\text{A}; V_{DS} = 15\text{ V}; V_{G1-S} = 0$

$-V_{(P)G1-S}$	<	2,5 V
$-V_{(P)G2-S}$	<	2,0 V

DYNAMIC CHARACTERISTICS

Measuring conditions (common source): $I_D = 10\text{ mA}; V_{DS} = 15\text{ V}; +V_{G2-S} = 4\text{ V}; T_{amb} = 25\text{ }^\circ\text{C}$.

Transfer admittance at $f = 1\text{ kHz}$	$ y_{fs} $	>	15 mS
		typ.	18 mS
Input capacitance at gate 1: $f = 1\text{ MHz}$	C_{ig1-s}	typ.	2,5 pF
		<	3,0 pF
Input capacitance at gate 2: $f = 1\text{ MHz}$	C_{ig2-s}	typ.	1,2 pF
Feedback capacitance at $f = 1\text{ MHz}$	C_{rs}	typ.	25 fF
Output capacitance at $f = 1\text{ MHz}$	C_{os}	typ.	1,0 pF
Noise figure at $G_S = 2\text{ mS}$ and $f = 200\text{ MHz}$	F	typ.	1,0 dB
Power gain at $G_S = 2\text{ mS}$ $G_L = 0,5\text{ mS}; f = 200\text{ MHz}$	G_p	typ.	25 dB

SILICON N-CHANNEL DUAL GATE MOS-FET

Depletion type field-effect transistor in a plastic microminiature envelope, with source and substrate interconnected, intended for u.h.f. applications, such as television tuners and professional communication equipment.

This MOS-FET tetrode is protected against excessive input voltage surges by integrated back-to-back diodes between gates and source.

QUICK REFERENCE DATA

Drain-source voltage	V_{DS}	max.	20 V
Drain current (average)	$I_{D(AV)}$	max.	30 mA
Total power dissipation up to $T_{amb} = 60\text{ }^{\circ}\text{C}$	P_{tot}	max.	200 mW
Junction temperature	T_j	max.	150 $^{\circ}\text{C}$
Transfer admittance at $f = 1\text{ kHz}$ $I_D = 10\text{ mA}; V_{DS} = 15\text{ V}; +V_{G2-S} = 4\text{ V}$	$ y_{fs} $	typ.	17 mS
Feedback capacitance at $f = 1\text{ MHz}$ $I_D = 10\text{ mA}; V_{DS} = 15\text{ V}; +V_{G2-S} = 4\text{ V}$	C_{rs}	typ.	25 fF
Noise figure at optimum source admittance $I_D = 10\text{ mA}; V_{DS} = 10\text{ V}; +V_{G2-S} = 4\text{ V}; f = 800\text{ MHz}$	F	typ.	2,8 dB
$I_D = 10\text{ mA}; V_{DS} = 15\text{ V}; +V_{G2-S} = 4\text{ V}; f = 200\text{ MHz}$	F	typ.	1,5 dB

MECHANICAL DATA

Fig. 1 SOT-143.

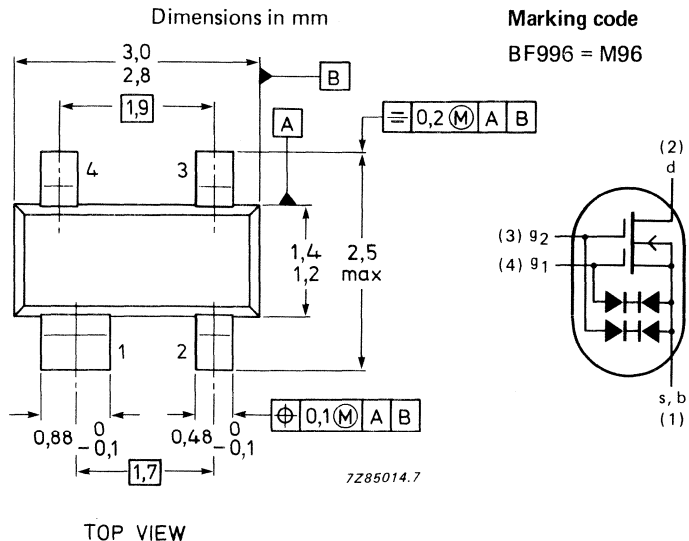
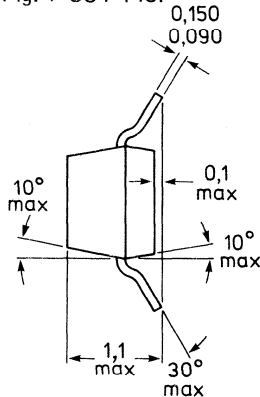

See also *Soldering recommendations*.

RATINGS

Limiting values in accordance with the Absolute Maximum System (IEC 134)

Drain-source voltage	V_{DS}	max.	20 V
Drain current (average)	$I_{D(AV)}$	max.	30 mA
Gate 1-source current	$\pm I_{G1-S}$	max.	10 mA
Gate 2-source current	$\pm I_{G2-S}$	max.	10 mA
Total power dissipation up to $T_{amb} = 60\text{ }^{\circ}\text{C}^*$	P_{tot}	max.	200 mW
Storage temperature	T_{stg}		-65 to + 150 $^{\circ}\text{C}$
Junction temperature	T_j	max.	150 $^{\circ}\text{C}$

THERMAL RESISTANCE

From junction to ambient in free air* $R_{th\ j-a} = 460\text{ K/W}$

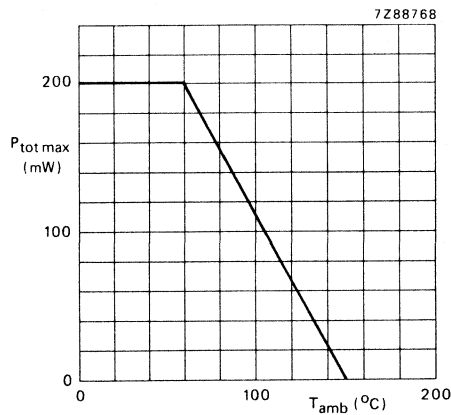

Fig. 2 Power derating curve.

* Device mounted on a ceramic substrate of 8 mm x 10 mm x 0,7 mm.

STATIC CHARACTERISTICS $T_{amb} = 25\text{ }^{\circ}\text{C}$ unless otherwise specified

Gate cut-off currents

gate 1; $\pm V_{G1-S} = 5\text{ V}; V_{G2-S} = V_{DS} = 0$	$\pm I_{G1-SS}$	<	50 nA
gate 2; $\pm V_{G2-S} = 5\text{ V}; V_{G1-S} = V_{DS} = 0$	$\pm I_{G2-SS}$	<	50 nA

Gate-source breakdown voltages

gate 1; $\pm I_{G1-SS} = 10\text{ mA}; V_{G2-S} = V_{DS} = 0$	$\pm V_{(BR)G1-SS}$		6 to 20 V
gate 2; $\pm I_{G2-SS} = 10\text{ mA}; V_{G1-S} = V_{DS} = 0$	$\pm V_{(BR)G2-SS}$		6 to 20 V

Gate-source cut-off voltages

gate 1; $I_D = 20\text{ }\mu\text{A}; V_{DS} = 15\text{ V}; +V_{G2-S} = 4\text{ V}$	$-V_{(P)G1-S}$	<	2,5 V
gate 2; $I_D = 20\text{ }\mu\text{A}; V_{DS} = 15\text{ V}; V_{G1-S} = 0$	$-V_{(P)G2-S}$	<	2,0 V

Drain-source cut-off voltage

$V_{DS} = 15\text{ V}; V_{G2-S} = 4\text{ V}$	I_{DSS}		2 to 20 mA
---	-----------	--	------------

DYNAMIC CHARACTERISTICSMeasuring conditions (common source): $I_D = 10\text{ mA}; V_{DS} = 15\text{ V}; +V_{G2-S} = 4\text{ V}; T_{amb} = 25\text{ }^{\circ}\text{C}$

Transfer admittance at $f = 1\text{ kHz}$	$ y_{fs} $	>	15 mS
		typ.	17 mS
Input capacitance at gate 1; $f = 1\text{ MHz}$	C_{ig1-s}	typ.	2,2 pF
Input capacitance at gate 2; $f = 1\text{ MHz}$	C_{ig2-s}	typ.	1,1 pF
Feedback capacitance at $f = 1\text{ MHz}$	C_{rs}	typ.	25 fF
Output capacitance at $f = 1\text{ MHz}$	C_{os}	typ.	0,8 pF
Noise figure			
at $G_S = 2\text{ mS}, f = 200\text{ MHz}$	F	typ.	1,5 dB
at $G_S = 2\text{ mS}, f = 800\text{ MHz}$	F	typ.	2,8 dB
		<	3,9 dB
Power gain			
$G_S = 2\text{ mS}, G_L = 0,5\text{ mS}, f = 200\text{ MHz}$	G_p	typ.	25 dB
$G_S = 2\text{ mS}, G_L = 1,0\text{ mS}, f = 800\text{ MHz}$	G_p	typ.	18 dB

SILICON N-CHANNEL DUAL GATE MOS-FET

Depletion type field-effect transistor in a plastic microminiature envelope (SOT-143) with source and substrate interconnected and intended for u.h.f. applications in television tuners, using SMD* technology. The device is also suitable for use in professional communication equipment.

This MOS-FET tetrode is protected against excessive input voltage surges by integrated back-to-back diodes between gates and source.

* Surface Mounted Devices

QUICK REFERENCE DATA

Drain-source voltage	V_{DS}	max.	20 V
Drain current	I_D	max.	30 mA
Total power dissipation up to $T_{amb} = 25\text{ }^\circ\text{C}$	P_{tot}	max.	300 mW
Junction temperature	T_j	max.	150 $^\circ\text{C}$
Transfer admittance at $f = 1\text{ kHz}$ $I_D = 10\text{ mA}; V_{DS} = 15\text{ V}; +V_{G2-S} = 4\text{ V}$	$ y_{fs} $	typ.	18 mS
Feedback capacitance at $f = 1\text{ MHz}$ $I_D = 10\text{ mA}; V_{DS} = 15\text{ V}; +V_{G2-S} = 4\text{ V}$	C_{rs}	typ.	25 fF
Noise figure at $G_S = 3,3\text{ mS}$ $I_D = 10\text{ mA}; V_{DS} = 15\text{ V}; +V_{G2-S} = 4\text{ V};$ $f = 800\text{ MHz}$	F	typ.	1,8 dB

MECHANICAL DATA

Fig. 1 SOT-143.

Dimensions in mm

Marking code

BF996S = M95

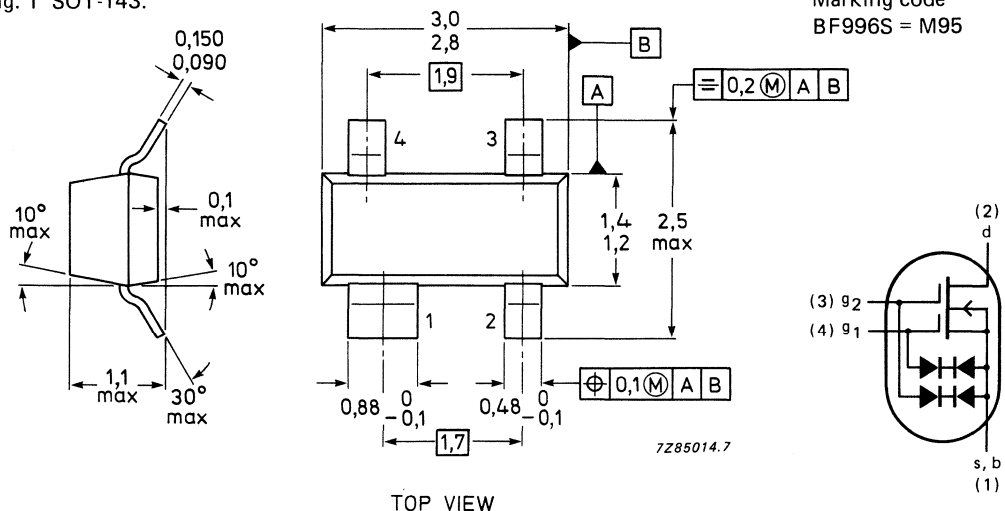

RATINGS

Limiting values in accordance with the Absolute Maximum System (IEC 134)

Drain-source voltage	V_{DS}	max.	20 V
Drain current (d.c. or average)	I_D	max.	30 mA
Gate 1 - source current	$\pm I_{G1-S}$	max.	10 mA
Gate 2 - source current	$\pm I_{G2-S}$	max.	10 mA
Total power dissipation up to $T_{amb} = 25\text{ }^\circ\text{C}$	P_{tot}	max.	300 mW
Storage temperature	T_{stg}		-65 to 150 $^\circ\text{C}$
Junction temperature	T_j	max.	150 $^\circ\text{C}$

THERMAL RESISTANCE

From junction to ambient in free air mounted on a ceramic substrate of 8 mm x 10 mm x 0,7 mm

$R_{th\ j-a}$	=	430 K/W
---------------	---	---------

STATIC CHARACTERISTICS

$T_j = 25\text{ }^\circ\text{C}$ unless otherwise specified

Gate cut-off currents

$\pm V_{G1-S} = 5\text{ V}, V_{G2-S} = V_{DS} = 0$	$\pm I_{G1-S}$	<	50 nA
$\pm V_{G2-S} = 5\text{ V}; V_{G1-S} = V_{DS} = 0$	$\pm I_{G2-S}$	<	50 nA

Gate-source breakdown voltages

$\pm I_{G1-S} = 10\text{ mA}; V_{G2-S} = V_{DS} = 0$	$\pm V_{(BR)G1-SS}$	6,0 to 20 V
$\pm I_{G2-S} = 10\text{ mA}; V_{G1-S} = V_{DS} = 0$	$\pm V_{(BR)G2-SS}$	6,0 to 20 V

Drain current

$V_{DS} = 15\text{ V}; V_{G1-S} = 0; V_{G2-S} = 4\text{ V}$	I_{DSS}	4 to 20 mA
---	-----------	------------

Gate-source cut-off voltages

$I_D = 20\text{ }\mu\text{A}; V_{DS} = 15\text{ V}; +V_{G2-S} = 4\text{ V}$	$-V_{(P)G1-S}$	<	2,5 V
$I_D = 20\text{ }\mu\text{A}; V_{DS} = 15\text{ V}; V_{G1-S} = 0$	$-V_{(P)G2-S}$	<	2,0 V

DYNAMIC CHARACTERISTICS

Measuring conditions (common source): $I_D = 10\text{ mA}; V_{DS} = 15\text{ V}; +V_{G2-S} = 4\text{ V}; T_{amb} = 25\text{ }^\circ\text{C}$.

Transfer admittance at $f = 1\text{ kHz}$	$ Y_{fs} $	>	15 mS
		typ.	18 mS
Input capacitance at gate 1: $f = 1\text{ MHz}$	C_{ig1-s}	typ.	2,3 pF
		<	2,6 pF
Input capacitance at gate 2: $f = 1\text{ MHz}$	C_{ig2-s}	typ.	1,2 pF
Feedback capacitance at $f = 1\text{ MHz}$	C_{rs}	typ.	25 fF
Output capacitance at $f = 1\text{ MHz}$	C_{os}	typ.	0,8 pF
Noise figure			
$f = 200\text{ MHz}; G_S = 2\text{ mS}$	F	typ.	1,0 dB
$f = 800\text{ MHz}; G_S = 3,3\text{ mS}$		typ.	1,8 dB
Power gain			
$f = 200\text{ MHz}; G_S = 2\text{ mS}; G_L = 0,5\text{ mS}$	G_p	typ.	25 dB
$f = 800\text{ MHz}; G_S = 3,3\text{ mS}; G_L = 1,0\text{ mS}$		typ.	18 dB

DEVELOPMENT DATA

This data sheet contains advance information and specifications are subject to change without notice.

BF997

SILICON N-CHANNEL DUAL GATE MOS-FET

Depletion type field-effect transistor in a plastic microminiature envelope with source and substrate interconnected, intended for u.h.f. and v.h.f. applications, such as u.h.f./v.h.f. television tuners and professional communication equipment.

This MOS-FET tetrode is protected against excessive input voltage surges by integrated back-to-back diodes between gates and source and has an integrated drain resistance to suppress oscillation in the frequency range higher than 1 GHz.

This device is especially intended for use in pre-amplifiers in CATV tuners with a great tuning range up to 500 MHz.

QUICK REFERENCE DATA

Drain-source voltage	V_{DS}	max.	20 V
Drain current (average)	$I_{D(AV)}$	max.	30 mA
Total power dissipation up to $T_{amb} = 25\text{ }^{\circ}\text{C}$	P_{tot}	max.	300 mW
Junction temperature	T_j	max.	150 $^{\circ}\text{C}$
Transfer admittance at $f = 1\text{ kHz}$ $I_D = 10\text{ mA}; V_{DS} = 15\text{ V}; +V_{G2-S} = 4\text{ V}$	$ Y_{fs} $	typ.	18 mS
Feedback capacitance at $f = 1\text{ MHz}$ $I_D = 10\text{ mA}; V_{DS} = 15\text{ V}; +V_{G2-S} = 4\text{ V}$	C_{rs}	typ.	25 fF
Noise figure at $G_S = 2\text{ mS}$ $I_D = 10\text{ mA}; V_{DS} = 15\text{ V}; +V_{G2-S} = 4\text{ V}; f = 200\text{ MHz}$	F	typ.	1,0 dB

MECHANICAL DATA

Dimensions in mm

Marking code:
M83

Fig. 1 SOT-143.

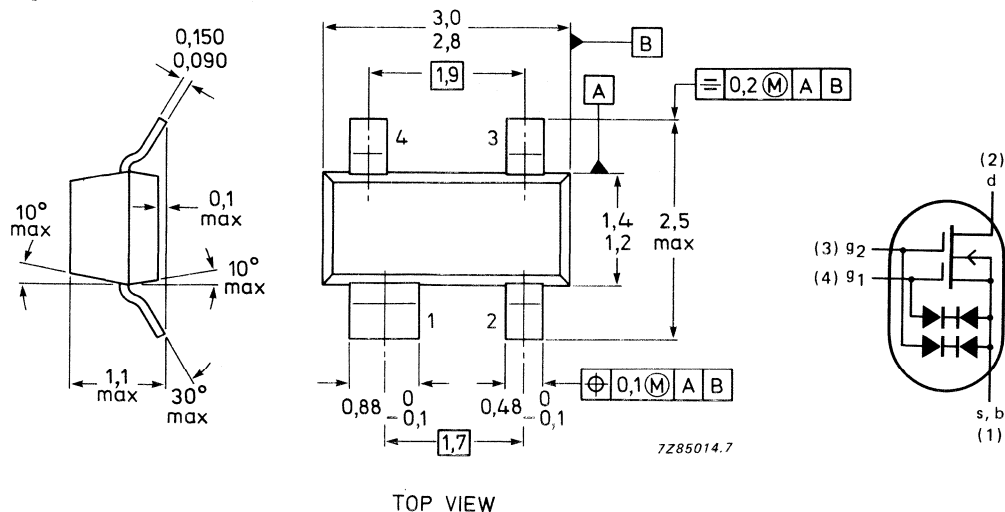

RATINGS

Limiting values in accordance with the Absolute Maximum System (IEC 134)

Drain-source voltage	V_{DS}	max.	20 V
Drain current (average)	$I_{D(AV)}$	max.	30 mA
Gate 1 source current	$\pm I_{G1-S}$	max.	10 mA
Gate 2 source current	$\pm I_{G2-S}$	max.	10 mA
Total power dissipation up to $T_{amb} = 25\text{ }^{\circ}\text{C}^*$	P_{tot}	max.	300 mW
Storage temperature	T_{stg}		-65 to + 150 $^{\circ}\text{C}$
Junction temperature	T_j	max.	150 $^{\circ}\text{C}$

THERMAL RESISTANCE

From junction to ambient in free air* $R_{th\ j-a} = 430\text{ K/W}$

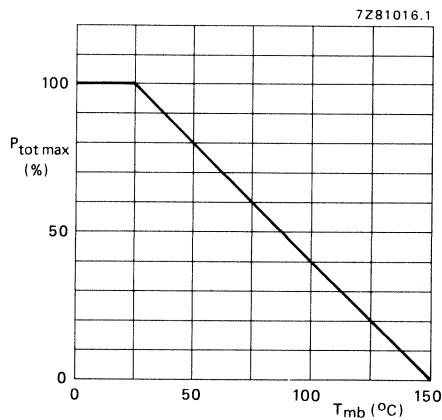

Fig. 2 Power derating curve.

* Device mounted on a ceramic substrate of 8 mm x 10 mm x 0,7 mm.

STATIC CHARACTERISTICS $T_{amb} = 25\text{ }^{\circ}\text{C}$ unless otherwise specified

Gate cut-off currents

gate 1; $\pm V_{G1-S} = 5\text{ V}; V_{G2-S} = V_{DS} = 0$	$\pm I_{G1-SS}$	<	50 nA
---	-----------------	---	-------

gate 2; $\pm V_{G2-S} = 5\text{ V}; V_{G1-S} = V_{DS} = 0$	$\pm I_{G2-SS}$	<	50 nA
---	-----------------	---	-------

Gate-source breakdown voltages

gate 1; $\pm I_{G1-SS} = 10\text{ mA}; V_{G2-S} = V_{DS} = 0$	$\pm V_{(BR)G1-SS}$		6 to 20 V
--	---------------------	--	-----------

gate 2; $\pm I_{G2-SS} = 10\text{ mA}; V_{G1-S} = V_{DS} = 0$	$\pm V_{(BR)G2-SS}$		6 to 20 V
--	---------------------	--	-----------

Gate-source cut-off voltages

gate 1; $I_D = 20\text{ }\mu\text{A}; V_{DS} = 15\text{ V}; +V_{G2-S} = 4\text{ V}$	$-V_{(P)G1-S}$	<	2,5 V
--	----------------	---	-------

gate 2; $I_D = 20\text{ }\mu\text{A}; V_{DS} = 15\text{ V}; V_{G1-S} = 0$	$-V_{(P)G2-S}$	<	2,0 V
--	----------------	---	-------

Drain-source cut-off voltage

$V_{DS} = 15\text{ V}; V_{G2-S} = 4\text{ V}; V_{G1-S} = 0$	I_{DSS}		2 to 20 mA
---	-----------	--	------------

DYNAMIC CHARACTERISTICSMeasuring conditions (common source): $I_D = 10\text{ mA}; V_{DS} = 15\text{ V}; +V_{G2-S} = 4\text{ V}; T_{amb} = 25\text{ }^{\circ}\text{C}$

Transfer admittance at $f = 1\text{ kHz}$	$ y_{fs} $	>	15 mS
		typ.	18 mS

Input capacitance at gate 1; $f = 1\text{ MHz}$	C_{ig1-s}	typ.	2,5 pF
---	-------------	------	--------

Input capacitance at gate 2; $f = 1\text{ MHz}$	C_{ig2-s}	typ.	1,2 pF
---	-------------	------	--------

Feedback capacitance at $f = 1\text{ MHz}$	C_{rs}	typ.	25 fF
--	----------	------	-------

Output capacitance at $f = 1\text{ MHz}$	C_{os}	typ.	1,0 pF
--	----------	------	--------

Noise figure at $f = 200\text{ MHz}; G_S = 2\text{ mS}$	F	typ.	1,0 dB
---	---	------	--------

Power gain at $G_S = 2\text{ mS}$ $G_L = 0,5\text{ mS}, f = 200\text{ MHz}$	G_p	typ.	25 dB
--	-------	------	-------

DEVELOPMENT DATA

N-P-N 2 GHz WIDEBAND TRANSISTOR

N-P-N transistor in a four lead dual-emitter plastic envelope (SOT-143). It is designed for wideband application in the GHz range, such as satellite TV systems (SATV) and repeater amplifiers in fibre-optical systems. The device features a very high transition frequency, high gain and a very low noise figure up to high frequencies.

QUICK REFERENCE DATA

Collector-base voltage	V_{CBO}	max.	20 V
Collector-emitter voltage	V_{CEO}	max.	10 V
Collector current (d.c.)	I_C	max.	50 mA
Total power dissipation up to $T_{amb} = 25\text{ °C}$	P_{tot}	max.	300 mW
Junction temperature	T_j	max.	150 °C
D.C. current gain $I_C = 15\text{ mA}; V_{CE} = 5\text{ V}$	h_{FE}	min. typ.	60 100
Transition frequency at $f = 500\text{ MHz}$ $I_C = 15\text{ mA}; V_{CE} = 8\text{ V}$	f_T	typ.	7,5 GHz
Maximum unilateral power gain at $f = 2\text{ GHz}$ $I_C = 15\text{ mA}; V_{CE} = 8\text{ V}; T_{amb} = 25\text{ °C}$	G_{UM}	typ.	10,0 dB
Noise figure at $f = 2\text{ GHz}$ $Z_S = 60\text{ }\Omega; T_{amb} = 25\text{ °C}$ $I_C = 5\text{ mA}; V_{CE} = 8\text{ V}$ $I_C = 15\text{ mA}; V_{CE} = 8\text{ V}$	F F	typ.	2,5 dB 3,0 dB

MECHANICAL DATA

Dimensions in mm

Fig. 1 SOT-143.

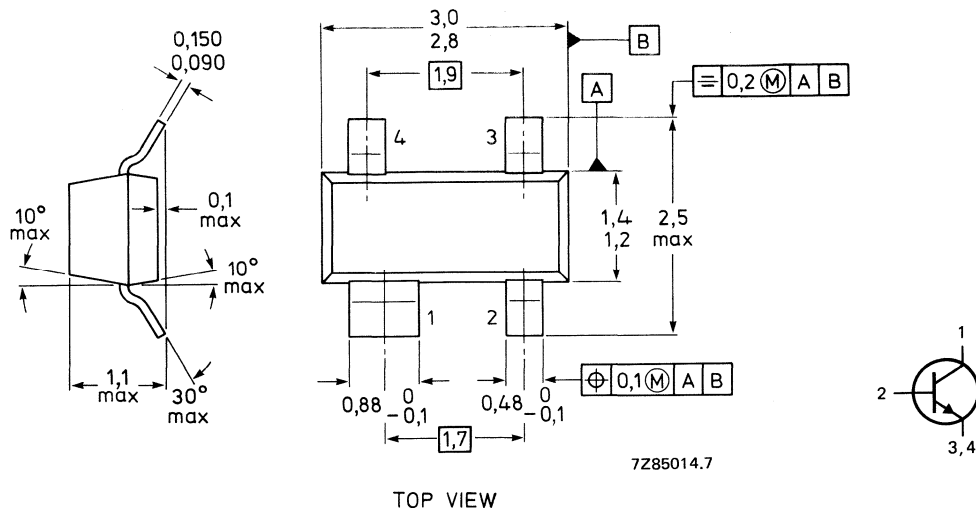

RATINGS

Limiting values in accordance with the Absolute Maximum System (IEC 134)

Collector-base voltage (open emitter)	V _{CB0}	max.	20 V
Collector-emitter voltage (open base)	V _{CE0}	max.	10 V
Emitter-base voltage (open collector)	V _{EBO}	max.	2,5 V
Collector current (d.c.)	I _C	max.	50 mA
Total power dissipation up to T _{amb} = 25 °C mounted on a ceramic substrate of 8 mm x 10 mm x 0,7 mm	P _{tot}	max.	300 mW
Storage temperature	T _{stg}		-65 to + 150 °C
Junction temperature	T _j	max.	150 °C

THERMAL RESISTANCE

From junction to ambient
mounted on a ceramic substrate of
8 mm x 10 mm x 0,7 mm

R _{th j-a}	=	430 K/W
---------------------	---	---------

CHARACTERISTICS

T_j = 25 °C unless otherwise specified

Collector cut-off current

I_E = 0; V_{CB} = 10 V

I _{CB0}	max.	50 nA
------------------	------	-------

D.C. current gain

I_C = 15 mA; V_{CE} = 5 V

h _{FE}	min.	60
	typ.	100

Transition frequency at f = 500 MHz

I_C = 15 mA; V_{CE} = 8 V

f _T	typ.	7,5 GHz
----------------	------	---------

Collector capacitance at f = 1 MHz

I_E = I_e = 0; V_{CB} = 8 V

C _c	typ.	0,7 pF
----------------	------	--------

Emitter capacitance at f = 1 MHz

I_C = I_c = 0; V_{EB} = 0,5 V

C _e	typ.	1,3 pF
----------------	------	--------

Feedback capacitance at f = 1 MHz

I_C = 0; V_{CE} = 8 V

C _{re}	typ.	0,5 pF
-----------------	------	--------

Maximum unilateral power gain (s_{re} assumed to be zero)

$$GUM = 10 \log \frac{|s_{fe}|^2}{[1 - |s_{ie}|^2][1 - |s_{oe}|^2]}$$

at I_C = 15 mA; V_{CE} = 8 V;
f = 2 GHz; T_{amb} = 25 °C

GUM	typ.	10,0 dB
-----	------	---------

Noise figures at f = 800 MHz; Z_S = opt.;

T_{amb} = 25 °C; V_{CE} = 8 V

I_C = 5 mA

I_C = 15 mA

F	typ.	0,8 dB
F	typ.	1,5 dB

Noise figures at f = 2 GHz; Z_S = 60 Ω

T_{amb} = 25 °C; V_{CE} = 8 V

I_C = 5 mA

I_C = 15 mA

F	typ.	2,5 dB
F	typ.	3,0 dB

s-parameters (common emitter) at $V_{CE} = 8\text{ V}$; $T_{amb} = 25\text{ }^{\circ}\text{C}$; typical values.

I_C mA	f MHz	S_{ie}	S_{fe}	S_{re}	S_{oe}	GUM dB
2	40	0,96/ -6,8°	5,8/177,8°	0,01/ 84,5°	0,99/ -3,2°	44,1
	100	0,98/ -20,8°	5,6/165,8°	0,03/ 77,5°	1,01/ -10,0°	46,5
	200	0,89/ -40,1°	5,1/153,2°	0,05/ 66,8°	0,91/ -19,0°	28,7
	500	0,81/ -89,3°	4,3/121,5°	0,09/ 43,4°	0,79/ -38,5°	21,5
	800	0,68/ -123,0°	3,3/102,0°	0,11/ 33,8°	0,67/ -50,0°	15,7
	1000	0,64/ -139,9°	2,8/ 89,8°	0,11/ 28,0°	0,65/ -54,5°	13,7
	1200	0,60/ -157,3°	2,3/ 81,1°	0,11/ 25,8°	0,62/ -61,7°	11,5
	1500	0,59/ -173,3°	2,0/ 71,8°	0,11/ 27,4°	0,55/ -69,3°	9,5
2000	0,57/ +161,7°	1,5/ 56,3°	0,10/ 32,2°	0,54/ -85,8°	6,7	
5	40	0,91/ -10,9°	13,5/174,8°	0,01/ 83,3°	0,98/ -5,9°	44,2
	100	0,91/ -30,3°	12,6/159,5°	0,03/ 72,2°	0,96/ -17,0°	40,9
	200	0,79/ -56,3°	10,6/143,5°	0,04/ 60,3°	0,81/ -29,5°	29,3
	500	0,64/ -115,9°	7,4/109,8°	0,07/ 41,4°	0,58/ -50,8°	21,5
	800	0,55/ -145,5°	5,2/ 93,5°	0,08/ 39,9°	0,48/ -59,5°	17,1
	1000	0,53/ -161,4°	4,2/ 84,0°	0,08/ 39,1°	0,44/ -62,2°	15,0
	1200	0,52/ -176,5°	3,5/ 77,8°	0,08/ 41,2°	0,42/ -67,1°	13,1
	1500	0,51/ +172,2°	2,9/ 69,1°	0,09/ 44,6°	0,38/ -75,7°	11,3
2000	0,50/ +149,8°	2,2/ 56,7°	0,11/ 49,8°	0,38/ -89,5°	8,7	
10	40	0,85/ -16,1°	23,5/170,6°	0,01/ 80,1°	0,96/ -9,7°	43,8
	100	0,81/ -42,6°	21,3/151,8°	0,02/ 67,2°	0,89/ -25,2°	38,0
	200	0,67/ -76,3°	16,6/133,0°	0,04/ 55,5°	0,68/ -40,0°	29,6
	500	0,54/ -137,5°	9,5/101,5°	0,05/ 45,7°	0,42/ -60,2°	21,9
	800	0,49/ -161,8°	6,3/ 88,5°	0,07/ 49,2°	0,35/ -67,0°	17,7
	1000	0,49/ -175,2°	5,1/ 80,5°	0,07/ 50,6°	0,32/ -68,9°	15,8
	1200	0,49/ +171,5°	4,2/ 75,8°	0,08/ 53,4°	0,29/ -72,5°	13,9
	1500	0,47/ +163,5°	3,5/ 67,5°	0,09/ 55,3°	0,28/ -82,1°	12,3
2000	0,47/ +142,5°	2,6/ 56,8°	0,12/ 57,7°	0,29/ -94,5°	9,6	
15	40	0,80/ -20,1°	31,0/167,8°	0,01/ 76,4°	0,94/ -12,2°	43,5
	100	0,74/ -51,8°	26,9/146,8°	0,02/ 64,1°	0,83/ -30,3°	37,2
	200	0,60/ -89,4°	19,9/126,7°	0,03/ 54,0°	0,60/ -45,5°	29,8
	500	0,51/ -147,5°	10,3/ 98,0°	0,05/ 49,7°	0,35/ -64,9°	22,1
	800	0,47/ -168,5°	6,7/ 86,5°	0,06/ 54,6°	0,29/ -70,8°	18,1
	1000	0,47/ +179,2°	5,4/ 79,3°	0,07/ 55,9°	0,27/ -72,8°	16,1
	1200	0,48/ +166,5°	4,4/ 75,0°	0,08/ 58,4°	0,24/ -75,8°	14,3
	1500	0,46/ +160,0°	3,7/ 67,0°	0,10/ 59,2°	0,24/ -86,0°	12,5
2000	0,45/ +139,5°	2,7/ 56,8°	0,12/ 60,2°	0,25/ -97,8°	10,0	
20	40	0,76/ -23,8°	37,2/165,4°	0,01/ 75,6°	0,92/ -14,3°	43,3
	100	0,69/ -60,0°	31,2/142,6°	0,02/ 61,7°	0,78/ -34,3°	36,8
	200	0,55/ -99,6°	21,8/122,5°	0,03/ 53,6°	0,54/ -49,5°	29,8
	500	0,49/ -152,5°	10,6/ 96,0°	0,04/ 53,0°	0,31/ -68,0°	22,2
	800	0,46/ -172,9°	7,0/ 85,0°	0,06/ 58,1°	0,26/ -73,3°	18,2
	1000	0,46/ +175,9°	5,5/ 78,3°	0,07/ 59,3°	0,24/ -75,3°	16,1
	1200	0,47/ +163,5°	4,6/ 74,3°	0,08/ 61,5°	0,21/ -78,3°	14,5
	1500	0,45/ +157,9°	3,8/ 66,4°	0,10/ 61,4°	0,22/ -88,9°	12,8
2000	0,45/ +137,8°	2,8/ 56,7°	0,12/ 61,7°	0,22/ -100,2°	10,2	

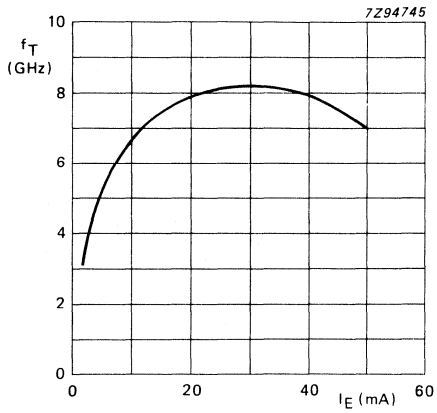

Fig. 2 $V_{CE} = 8$ V; $f = 500$ MHz;
 $T_{amb} = 25$ °C; typical values.

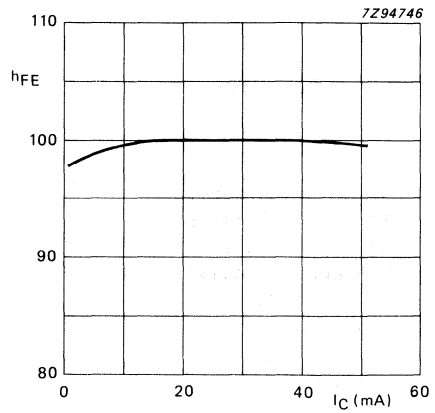

Fig. 3 $V_{CE} = 5$ V; $T_{amb} = 25$ °C;
 typical values.

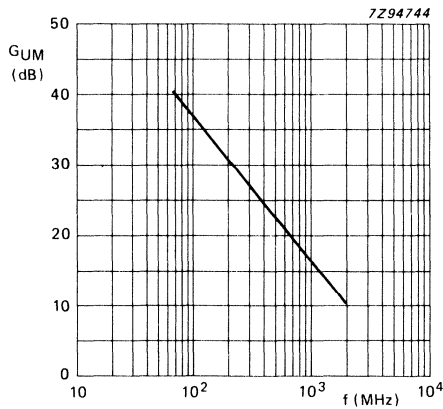

Fig. 4 $V_{CE} = 8$ V; $I_C = 15$ mA;
 $T_{amb} = 25$ °C; typical values.

N-P-N H.F. WIDEBAND TRANSISTOR

N-P-N multi-emitter transistor in a SOT-89 plastic envelope intended for application in thick and thin-film circuits. The transistor has extremely good intermodulation properties and a high power gain. It is primarily intended for:

- Output and driver stages of channel and band serial amplifiers with high output power for bands I, II, III and IV/V (40–860 MHz).
- Output and driver stages of wideband amplifiers.

QUICK REFERENCE DATA

Collector-base voltage (open emitter; peak value)	V_{CBOM}	max.	40 V
Collector-emitter voltage (open base)	V_{CEO}	max.	25 V
Collector current (peak value; $f > 1$ MHz)	I_{CM}	max.	300 mA
Total power dissipation up to $T_{amb} = 25$ °C	P_{tot}	max.	1 W
Junction temperature	T_j	max.	150 °C
Transition frequency at $f = 500$ MHz $I_C = 150$ mA; $V_{CE} = 15$ V	f_T	typ.	1,2 GHz
Feedback capacitance at $f = 1$ MHz $I_C = 10$ mA; $V_{CE} = 15$ V;	C_{re}	typ.	1,9 pF

MECHANICAL DATA

Fig. 1 SOT-89.

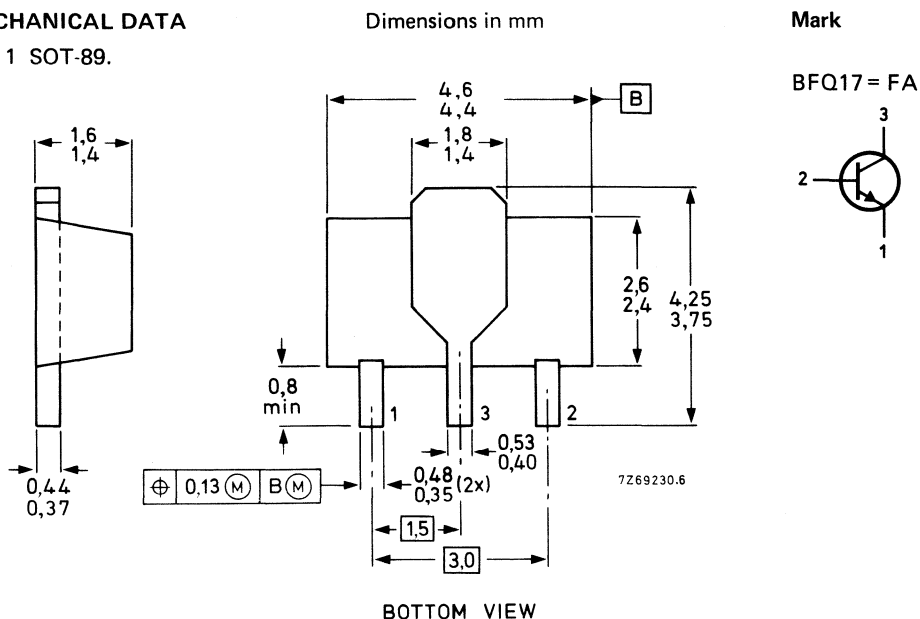

See also *Soldering recommendations*.

RATINGS Limiting values in accordance with the Absolute Maximum System (IEC 134)

Collector-base voltage (open emitter; peak value)	V_{CBOM}	max.	40	V
Collector-emitter voltage ($R_{BE} \leq 50 \Omega$; peak value)	V_{CERM}	max.	40	V 1)
Collector-emitter voltage (open base)	V_{CEO}	max.	25	V 1)
Emitter-base voltage (open collector)	V_{EB0}	max.	2	V
Collector current (d. c.)	I_C	max.	150	mA
Collector current (peak value; $f > 1$ MHz)	I_{CM}	max.	300	mA
Total power dissipation up to $T_{amb} = 25 \text{ }^\circ\text{C}$ mounted on a ceramic substrate area = 2,5 cm ² ; thickness = 0,7 mm				
	P_{tot}	max.	1	W
Storage temperature	T_{stg}		-65 to +150	$^\circ\text{C}$
Junction temperature	T_j	max.	150	$^\circ\text{C}$

THERMAL RESISTANCE

From junction to collector tab	$R_{thj-tab}$	=	30	K/W
From junction to ambient in free air mounted on a ceramic substrate area = 2,5 cm ² ; thickness = 0,7 mm	R_{thj-a}	=	125	K/W

1) $I_C = 10$ mA.

CHARACTERISTICS

$T_j = 25\text{ }^\circ\text{C}$ unless otherwise specified

Collector cut-off current

$I_E = 0; V_{CB} = 20\text{ V}; T_j = 150\text{ }^\circ\text{C}$ I_{CBO} max. 20 μA

Saturation voltage

$I_C = 100\text{ mA}; I_B = 10\text{ mA}$ V_{CEsat} max. 0,5 V

D.C. current gain

$I_C = 50\text{ mA}; V_{CE} = 5\text{ V}$ h_{FE} min. 25

$I_C = 150\text{ mA}; V_{CE} = 5\text{ V}$ h_{FE} min. 25

Transition frequency at $f = 500\text{ MHz}$ ¹⁾

$I_C = 150\text{ mA}; V_{CE} = 15\text{ V}$ f_T typ. 1,2 GHz

Collector capacitance at $f = 1\text{ MHz}$

$I_E = I_e = 0; V_{CB} = 15\text{ V}$ C_c max. 4 pF

Feedback capacitance at $f = 1\text{ MHz}$

$I_C = 10\text{ mA}; V_{CE} = 15\text{ V}; T_{amb} = 25\text{ }^\circ\text{C}$ C_{re} typ. 1,9 pF

Max. unilateral power gain (s_{re} assumed to be zero)

$$GUM = 10 \log \frac{|s_{fe}|^2}{(1 - |s_{ie}|^2)(1 - |s_{oe}|^2)}$$

$I_C = 60\text{ mA}; V_{CE} = 15\text{ V}; T_{amb} = 25\text{ }^\circ\text{C};$

$f = 200\text{ MHz}$

$f = 800\text{ MHz}$

GUM typ. 16 dB

GUM typ. 6,5 dB

¹⁾ Measured under pulse conditions.

7Z72947

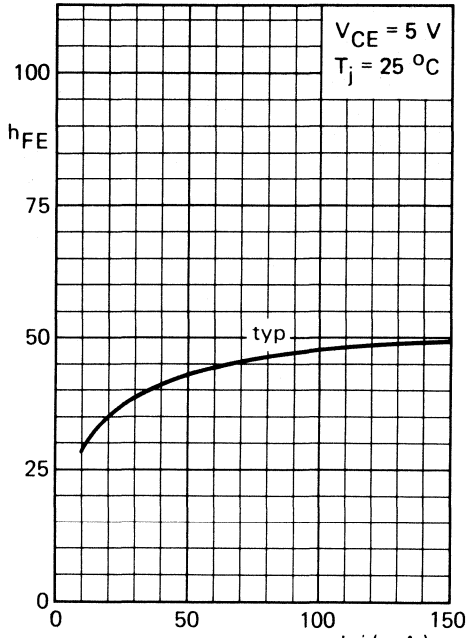

Fig. 2. $V_{CE} = 5\text{ V}$; $T_j = 25\text{ }^\circ\text{C}$; I_C (mA) typical values

7Z72950

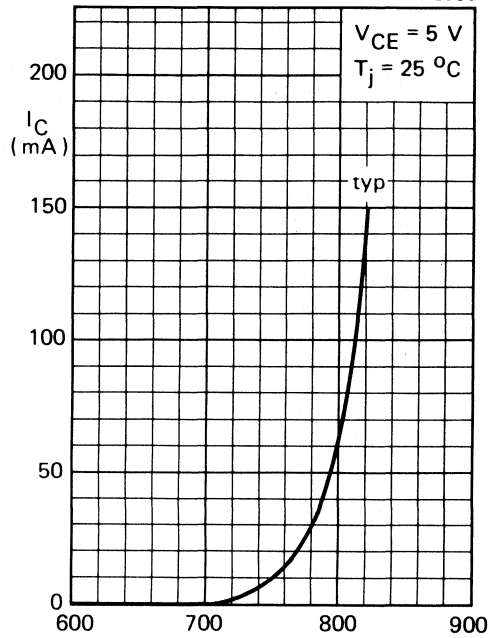

Fig. 3. $V_{CE} = 5\text{ V}$; $T_j = 25\text{ }^\circ\text{C}$; V_{BE} (mV) typical values

7Z72948

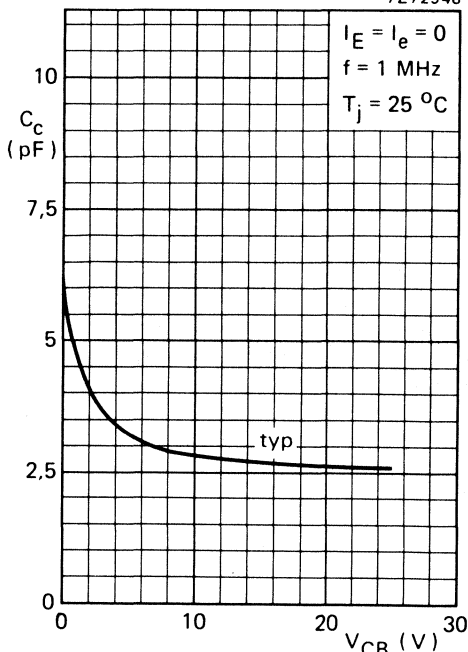

Fig. 4. $I_E = I_e = 0$; $f = 1\text{ MHz}$; $T_j = 25\text{ }^\circ\text{C}$; typical values

7Z73167

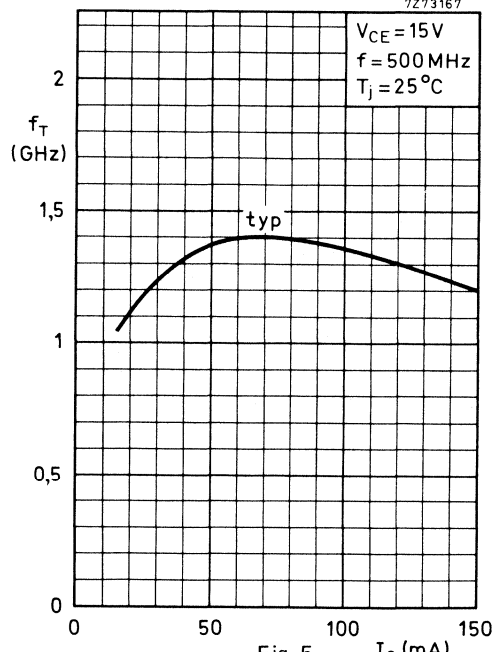

Fig. 5. $V_{CE} = 15\text{ V}$; $f = 500\text{ MHz}$; $T_j = 25\text{ }^\circ\text{C}$; typical values

N-P-N H.F. WIDEBAND TRANSISTOR

N-P-N transistor in a plastic SOT-89 envelope intended for application in thick and thin-film circuits. It is primarily intended for MATV purposes.

QUICK REFERENCE DATA

Collector-base voltage (open emitter)	V_{CBO}	max.	25 V
Collector-emitter voltage (open base)	V_{CEO}	max.	15 V
Collector current (d.c.)	I_C	max.	150 mA
Total power dissipation up to $T_{amb} = 25\text{ }^\circ\text{C}$	P_{tot}	max.	1 W
Junction temperature	T_j	max.	150 $^\circ\text{C}$
Transition frequency at $f = 500\text{ MHz}$ $I_C = 100\text{ mA}; V_{CE} = 10\text{ V}$	f_T	typ.	3,6 GHz
Feedback capacitance at $f = 10,7\text{ MHz}$ $I_C = 0; V_{CE} = 10\text{ V}$	C_{re}	typ.	1,2 pF
Intermodulation distortion $I_C = 80\text{ mA}; V_{CE} = 10\text{ V}; R_L = 75\text{ }\Omega$ measured at $f(p + q - r) = 793,25\text{ MHz}$	d_{im}	max.	-60 dB

MECHANICAL DATA

Fig. 1 SOT-89.

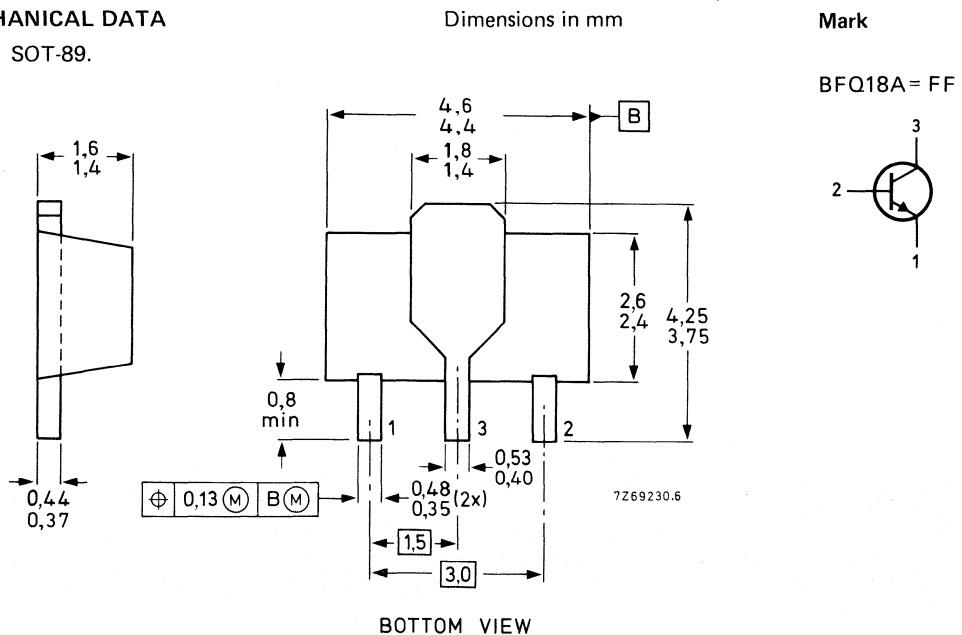

See also soldering recommendations

RATINGS

Limiting values in accordance with the Absolute Maximum System (IEC 134)

Collector-base voltage (open emitter)	V_{CBO}	max.	25 V
Collector-emitter voltage (open base)	V_{CEO}	max.	15 V
Emitter-base voltage (open collector)	V_{EBO}	max.	2 V
Collector current (d.c.)	I_C	max.	150 mA
Total power dissipation up to $T_{amb} = 25\text{ }^\circ\text{C}$ *	P_{tot}	max.	1 W
Storage temperature	T_{stg}		-65 to + 150 $^\circ\text{C}$
Junction temperature	T_j	max.	150 $^\circ\text{C}$

THERMAL RESISTANCE

From junction to collector tab	$R_{th\ j-tab}$	=	25 K/W
From junction to ambient in free air *	$R_{th\ j-a}$	=	125 K/W

CHARACTERISTICS

 $T_{amb} = 25\text{ }^\circ\text{C}$ unless otherwise specified

D.C. current gain **

$I_C = 50\text{ mA}; V_{CE} = 10\text{ V}$	h_{FE}	min.	25
$I_C = 100\text{ mA}; V_{CE} = 10\text{ V}$	h_{FE}	min.	25

Transition frequency at $f = 500\text{ MHz}$ **

$I_C = 50\text{ mA}; V_{CE} = 10\text{ V}$	f_T	typ.	3,2 GHz
$I_C = 100\text{ mA}; V_{CE} = 10\text{ V}$	f_T	typ.	3,6 GHz

Collector capacitance at $f = 1\text{ MHz}$

$I_E = I_e = 0; V_{CB} = 10\text{ V}$	C_c	typ.	2,0 pF
---------------------------------------	-------	------	--------

Emitter capacitance at $f = 1\text{ MHz}$

$I_C = I_c = 0; V_{EB} = 0,5\text{ V}$	C_e	typ.	11 pF
--	-------	------	-------

Feedback capacitance at $f = 10,7\text{ MHz}$

$I_C = 0; V_{CE} = 10\text{ V}$	C_{re}	typ.	1,2 pF
---------------------------------	----------	------	--------

* The device mounted on a ceramic substrate area = 2,5 cm²; thickness = 0,7 mm.

** Measured under pulse conditions.

Intermodulation distortion (see Fig. 2)

$I_C = 80 \text{ mA}$; $V_{CE} = 10 \text{ V}$; $R_L = 75 \Omega$
 $V_p = V_o = 700 \text{ mV}$ at $f_p = 795,25 \text{ MHz}$
 $V_q = V_o - 6 \text{ dB}$ at $f_q = 803,25 \text{ MHz}$
 $V_r = V_o - 6 \text{ dB}$ at $f_r = 805,25 \text{ MHz}$

Measured at $f_{(p+q-r)} = 793,25 \text{ MHz}$

d_{im} max. -60 dB

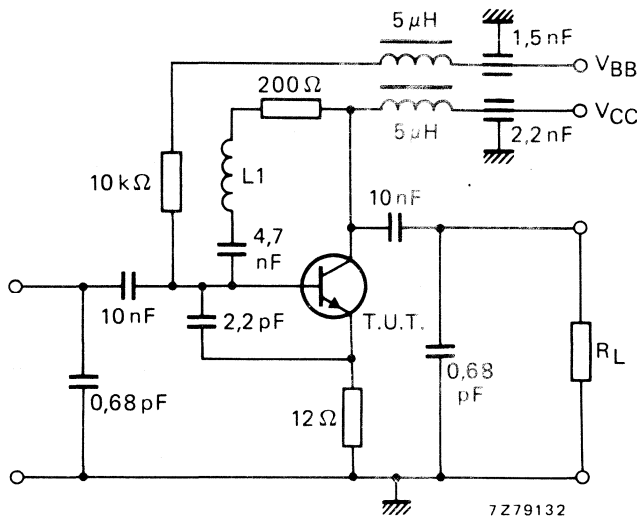

Fig. 2 MATV-test circuit (40--860 MHz).

N-P-N 1 GHz WIDEBAND TRANSISTOR

N-P-N transistor in a SOT-89 plastic envelope intended for application in thick- and thin-film circuits.

It is primarily intended for use in u.h.f. and microwave amplifiers such as in aerial amplifiers, radar systems, oscilloscopes, spectrum analysers etc.

The transistor features very low intermodulation distortion and high power gain. Thanks to its very high transition frequency, it also has excellent wideband properties and low noise up to high frequencies.

QUICK REFERENCE DATA

Collector-base voltage (open emitter)	V_{CBO}	max.	20	V
Collector-emitter voltage (open base)	V_{CEO}	max.	15	V
Collector current (d.c.)	I_C	max.	75	mA
Total power dissipation up to $T_{amb} = 87,5\text{ }^\circ\text{C}$	P_{tot}	max.	500	mW
Junction temperature	T_j	max.	150	$^\circ\text{C}$
Transition frequency at $f = 500\text{ MHz}$ $I_C = 50\text{ mA}; V_{CE} = 10\text{ V}$	f_T	typ.	5	GHz
Feedback capacitance at $f = 1\text{ MHz}$ $I_C = 10\text{ mA}; V_{CE} = 10\text{ V};$	C_{re}	typ.	1,3	pF
Noise figure at optimum source impedance $I_C = 50\text{ mA}; V_{CE} = 10\text{ V}; f = 500\text{ MHz};$	F	typ.	3,3	dB

MECHANICAL DATA

Fig. 1 SOT-89.

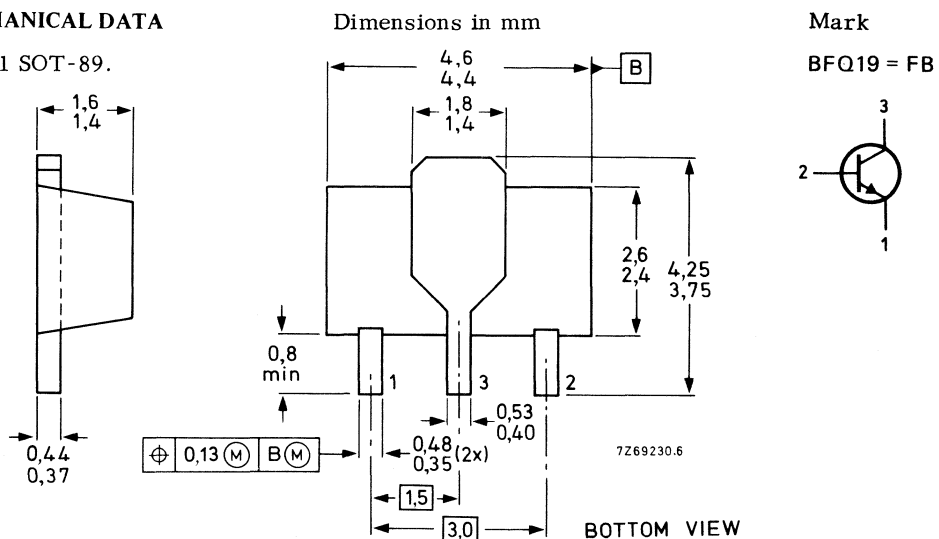

See also soldering recommendations

RATINGS Limiting values in accordance with the Absolute Maximum System (IEC134)

Collector-base voltage (open emitter)	V_{CBO}	max.	20	V
Collector-emitter voltage (open base)	V_{CEO}	max.	15	V
Emitter-base voltage (open collector)	V_{EBO}	max.	3,3	V
Collector current (d. c.)	I_C	max.	75	mA
Collector current (peak value); $f > 1$ MHz	I_{CM}	max.	150	mA
Total power dissipation up to $T_{amb} = 87,5$ °C mounted on a ceramic substrate area = $2,5$ cm ² ; thickness = $0,7$ mm	P_{tot}	max.	500	mW
Storage temperature	T_{stg}	-65 to +150		°C
Junction temperature	T_j	max.	150	°C
THERMAL RESISTANCE				
From junction to collector tab	$R_{thj-tab}$	=	40	K/W
From junction to ambient in free air mounted on a ceramic substrate area = $2,5$ cm ² ; thickness = $0,7$ mm	R_{thj-a}	=	125	K/W

CHARACTERISTICS

$T_j = 25\text{ }^\circ\text{C}$ unless otherwise specified

Collector cut-off current

$I_E = 0; V_{CB} = 10\text{ V}$ I_{CBO} max. 100 nA

D.C. current gain 1)

$I_C = 50\text{ mA}; V_{CE} = 10\text{ V}$ h_{FE} min. 25
typ. 50

$I_C = 75\text{ mA}; V_{CE} = 10\text{ V}$ h_{FE} min. 25
typ. 52

Transition frequency at $f = 500\text{ MHz}$ 1)

$I_C = 50\text{ mA}; V_{CE} = 10\text{ V}$ f_T min. 4,0 GHz
typ. 5,0 GHz

$I_C = 75\text{ mA}; V_{CE} = 10\text{ V}$ f_T min. 4,4 GHz
typ. 5,5 GHz

Collector capacitance at $f = 1\text{ MHz}$

$I_E = I_e = 0; V_{CB} = 10\text{ V}$ C_c typ. 1,6 pF

Emitter capacitance at $f = 1\text{ MHz}$

$I_C = I_c = 0; V_{EB} = 0,5\text{ V}$ C_e typ. 5,0 pF

Feedback capacitance at $f = 1\text{ MHz}$

$I_C = 10\text{ mA}; V_{CE} = 10\text{ V}; T_{amb} = 25\text{ }^\circ\text{C}$ C_{re} typ. 1,3 pF

Noise figure at optimum source impedance

$I_C = 50\text{ mA}; V_{CE} = 10\text{ V}; f = 500\text{ MHz}; T_{amb} = 25\text{ }^\circ\text{C}$ F typ. 3,3 dB

Max. unilateral power gain (s_{re} assumed to be zero)

$$G_{UM} = 10 \log \frac{|s_{fe}|^2}{(1 - |s_{ie}|^2)(1 - |s_{oe}|^2)}$$

$I_C = 50\text{ mA}; V_{CE} = 10\text{ V}; T_{amb} = 25\text{ }^\circ\text{C};$

$f = 200\text{ MHz}$ G_{UM} typ. 18,5 dB

$f = 500\text{ MHz}$ G_{UM} typ. 11,5 dB

$f = 800\text{ MHz}$ G_{UM} typ. 7,5 dB

1) Measured under pulse conditions.

7Z72659

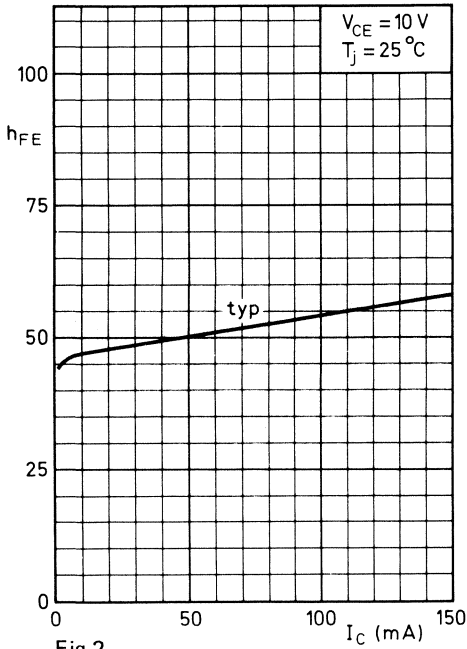

Fig.2.

7Z72950

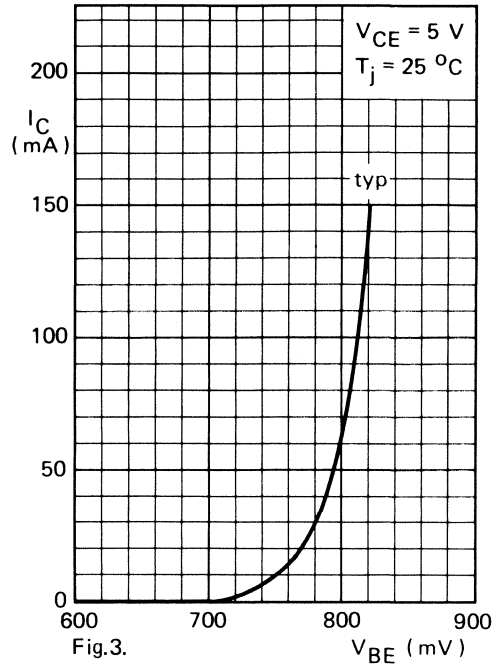

Fig.3.

7Z72949

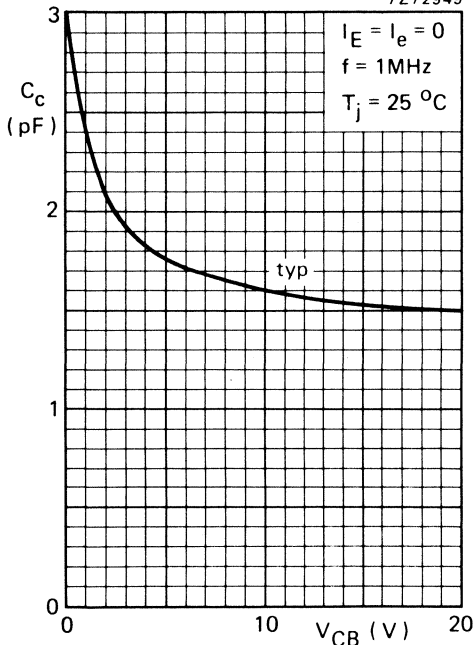

Fig.4.

7Z72655

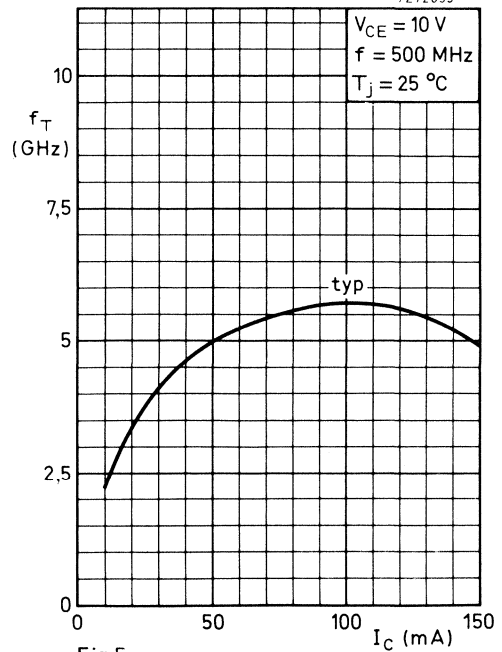

Fig.5.

N-P-N 2 GHz WIDEBAND TRANSISTOR

N-P-N transistor in a plastic SOT-23 envelope. It is designed for wideband application in the GHz range, such as satellite TV systems (SATV) and repeater amplifiers in fibre-optical systems. The device features a very high transition frequency and a very low noise figure up to high frequencies.

QUICK REFERENCE DATA

Collector-base voltage, open emitter	V_{CBO}	max.	20 V
Collector-emitter voltage, open base	V_{CEO}	max.	10 V
Collector current (d.c.)	I_C	max.	50 mA
Total power dissipation up to $T_{amb} = 70\text{ }^\circ\text{C}$	P_{tot}	max.	180 mW
Junction temperature	T_j	max.	150 $^\circ\text{C}$
D.C. current gain			
$I_C = 15\text{ mA}; V_{CB} = 5\text{ V}$	h_{FE}	typ.	100
Transition frequency at $f = 500\text{ MHz}$			
$I_C = 15\text{ mA}; V_{CE} = 8\text{ V}$	f_T	typ.	7,5 GHz
Maximum unilateral power gain at $f = 2\text{ GHz}$			
$I_C = 15\text{ mA}; V_{CE} = 8\text{ V}$	G_{UM}	typ.	8,0 dB

MECHANICAL DATA

Dimensions in mm

Fig. 1 SOT-23.

Mark : V2

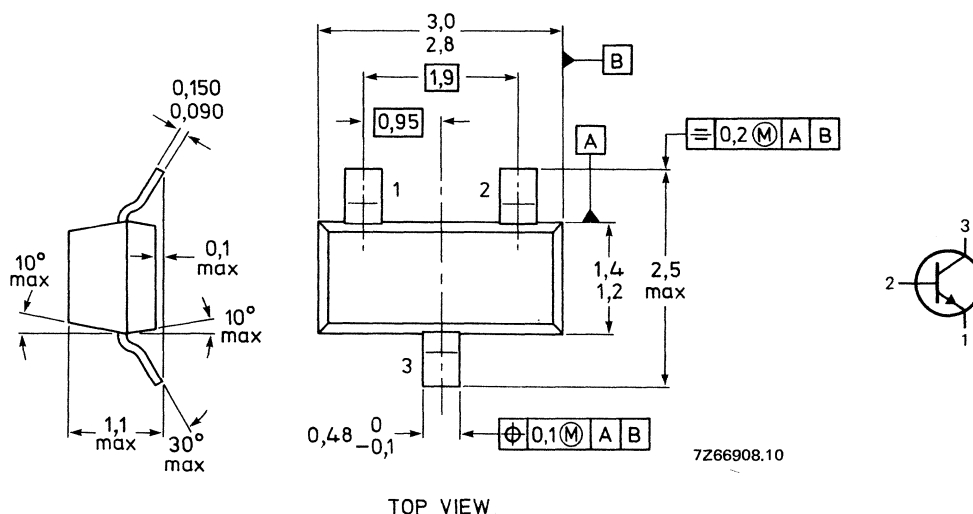

If required, the R-version (reverse pinning) is available on request.

RATINGS

Limiting values in accordance with the Absolute Maximum System (IEC 134)

Collector-base voltage (open emitter)	V_{CBO}	max.	20 V
Collector-emitter voltage (open base)	V_{CEO}	max.	10 V
Emitter-base voltage (open collector)	V_{EBO}	max.	2,5 V
Collector current (d.c.)	I_C	max.	50 mA
Total power dissipation up to $T_{amb} = 70\text{ }^\circ\text{C}^*$	P_{tot}	max.	180 mW
Storage temperature	T_{stg}		-65 to + 150 $^\circ\text{C}$
Junction temperature	T_j	max.	150 $^\circ\text{C}$

THERMAL RESISTANCE

From junction to ambient in free air*	R_{thj-a}	=	430 K/W
---------------------------------------	-------------	---	---------

CHARACTERISTICS $T_j = 25\text{ }^\circ\text{C}$ unless otherwise specified

Collector cut-off current

$I_E = 0; V_{CB} = 5\text{ V}$	I_{CBO}	max.	50 nA
--------------------------------	-----------	------	-------

D.C. current gain

$I_C = 15\text{ mA}; V_{CB} = 5\text{ V}$	h_{FE}	typ.	100
---	----------	------	-----

Transition frequency at $f = 500\text{ MHz}$

$I_C = 15\text{ mA}; V_{CE} = 8\text{ V}$	f_T	typ.	7,5 GHz
---	-------	------	---------

Collector capacitance at $f = 1\text{ MHz}$

$I_E = i_e = 0; V_{CB} = 8\text{ V}$	C_c	typ.	0,7 pF
--------------------------------------	-------	------	--------

Emitter capacitance at $f = 1\text{ MHz}$

$I_C = i_c = 0; V_{EB} = 0,5\text{ V}$	C_e	typ.	1,3 pF
--	-------	------	--------

Feedback capacitance at $f = 1\text{ MHz}$

$I_C = 0; V_{CE} = 8\text{ V}$	C_{re}	typ.	0,5 pF
--------------------------------	----------	------	--------

Maximum unilateral power gain (s_{re} assumed to be zero)

$G_{UM} = 10 \log \frac{ s_{fe} ^2}{[1 - s_{ie} ^2][1 - s_{oe} ^2]}$	G_{UM}	typ.	8,0 dB
$I_C = 15\text{ mA}; V_{CE} = 8\text{ V}; f = 2\text{ GHz}; T_{amb} = 25\text{ }^\circ\text{C}$			

Noise figure at $f = 2\text{ GHz}; R_S = 60\text{ } \Omega; T_{amb} = 25\text{ }^\circ\text{C}$

$I_C = 5\text{ mA}; V_{CE} = 8\text{ V}$	F	typ.	2,5 dB
$I_C = 15\text{ mA}; V_{CE} = 8\text{ V}$	F	typ.	3,0 dB

* Mounted on a ceramic substrate of 8 mm x 10 mm x 0,7 mm.

s-parameters (common emitter) at $V_{CE} = 8$ V; typical values.

I_C mA	f MHz	s_{ie}	s_{fe}	s_{re}	s_{oe}	G_{UM} dB
2	40	0,93/ -9,5°	7,07/174,6°	0,01/83,2°	1,00/ -4,5°	46,7
	100	0,90/ -22,8°	6,96/163,5°	0,03/76,3°	0,97/ -10,4°	36,4
	200	0,84/ -42,1°	6,35/150,4°	0,06/66,4°	0,91/ -17,9°	29,2
	500	0,61/ -90,7°	4,40/117,2°	0,10/45,7°	0,67/ -32,6°	17,5
	800	0,55/ -118,0°	3,24/102,6°	0,12/42,2°	0,60/ -38,2°	13,7
	1000	0,54/ -135,5°	2,76/ 93,5°	0,12/41,2°	0,55/ -43,6°	11,9
	2000	0,47/ 177,3°	1,57/ 64,5°	0,15/60,0°	0,47/ -65,3°	6,1
5	40	0,84/ -14,9°	15,47/170,5°	0,01/80,7°	0,99/ -7,9°	44,5
	100	0,78/ -36,1°	14,35/154,8°	0,03/71,1°	0,92/ -18,0°	35,4
	200	0,68/ -63,3°	11,97/137,7°	0,05/60,6°	0,79/ -29,0°	28,5
	500	0,45/ -119,8°	6,74/106,1°	0,08/49,7°	0,47/ -40,1°	18,6
	800	0,42/ -143,5°	4,55/ 94,7°	0,09/53,8°	0,41/ -41,5°	14,8
	1000	0,43/ -155,4°	3,80/ 87,4°	0,10/56,1°	0,37/ -46,7°	13,1
	2000	0,35/ 169,2°	2,04/ 63,5°	0,18/69,4°	0,34/ -63,3°	7,3
10	40	0,74/ -22,8°	25,66/165,6°	0,01/77,5°	0,96/ -12,1°	43,0
	100	0,65/ -51,2°	22,19/145,5°	0,03/66,8°	0,84/ -26,3°	34,6
	200	0,53/ -85,2°	16,35/126,4°	0,04/58,1°	0,64/ -38,4°	28,0
	500	0,38/ -144,4°	8,01/ 99,5°	0,06/58,0°	0,33/ -42,8°	19,2
	800	0,36/ -161,9°	5,29/ 90,0°	0,09/64,0°	0,30/ -41,2°	15,5
	1000	0,38/ 169,9°	4,27/ 84,0°	0,10/66,0°	0,27/ -47,0°	13,6
	2000	0,30/ 160,0°	2,29/ 62,8°	0,20/72,6°	0,27/ -61,2°	7,9
15	40	0,67/ -28,3°	32,67/162,1°	0,01/75,8°	0,94/ -14,9°	42,5
	100	0,57/ -62,8°	26,66/139,6°	0,02/64,6°	0,78/ -31,4°	34,2
	200	0,46/ -99,5°	18,35/120,6°	0,04/58,7°	0,56/ -42,8°	27,9
	500	0,36/ -154,8°	8,49/ 96,8°	0,06/62,9°	0,27/ -42,8°	19,5
	800	0,34/ 169,3°	5,55/ 88,4°	0,09/68,4°	0,26/ -39,7°	15,7
	1000	0,36/ 176,8°	4,47/ 82,5°	0,10/69,7°	0,23/ -46,3°	13,9
	2000	0,29/ 155,7°	2,37/ 62,3°	0,21/73,4°	0,25/ -59,8°	8,2
20	40	0,63/ -32,5°	37,50/159,4°	0,01/74,2°	0,93/ -17,2°	42,0
	100	0,52/ -70,8°	29,23/135,5°	0,02/63,4°	0,73/ -34,7°	34,0
	200	0,42/ -108,8°	19,22/117,4°	0,03/59,7°	0,50/ -45,0°	27,8
	500	0,35/ -162,0°	8,69/ 95,0°	0,06/64,9°	0,23/ -41,6°	19,6
	800	0,33/ -175,1°	5,62/ 86,9°	0,09/70,7°	0,24/ -38,1°	15,7
	1000	0,36/ -178,7°	4,57/ 81,7°	0,10/71,6°	0,21/ -45,0°	14,0
	2000	0,28/ -153,5°	2,40/ 62,0°	0,21/73,8°	0,24/ -58,9°	8,2

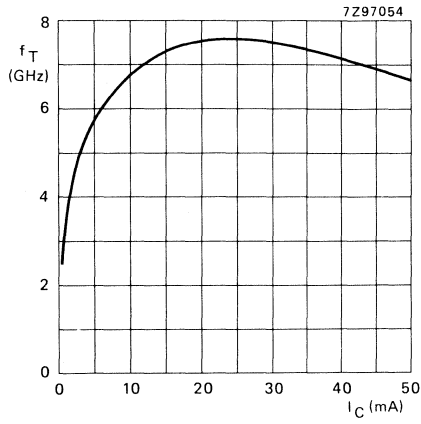

Fig. 2 $V_{CE} = 8 \text{ V}$; $f = 500 \text{ MHz}$; typical values.

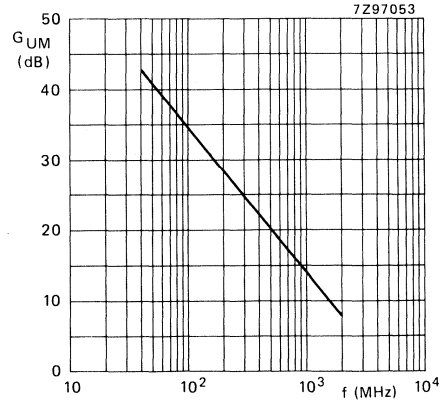

Fig. 3 $V_{CE} = 8 \text{ V}$; $I_C = 15 \text{ mA}$;
 $T_{amb} = 25 \text{ }^\circ\text{C}$; typical values.

N-CHANNEL SILICON FIELD-EFFECT TRANSISTORS

Planar epitaxial junction field effect transistor in a microminiature plastic envelope. It is intended for low level general purpose amplifiers in thick and thin-film circuits.

QUICK REFERENCE DATA

Drain-source voltage	$\pm V_{DS}$	max.	25	V
Gate-source voltage (open drain)	$-V_{GSO}$	max.	25	V
Total power dissipation up to $T_{amb} = 65\text{ }^{\circ}\text{C}$	P_{tot}	max.	250	mW
Drain current $V_{DS} = 10\text{ V}; V_{GS} = 0$	I_{DSS}	$>$	BFR30: 4	BFR31: 1 mA
		$<$	10	5 mA
Transfer admittance (common source) $I_D = 1\text{ mA}; V_{DS} = 10\text{ V}; f = 1\text{ kHz}$	$ y_{fs} $	$>$	1,0	1,5 mS
		$<$	4,0	4,5 mS

MECHANICAL DATA

Fig. 1 SOT-23.

Dimensions in mm

Marking code

BFR30 = M1
BFR31 = M2

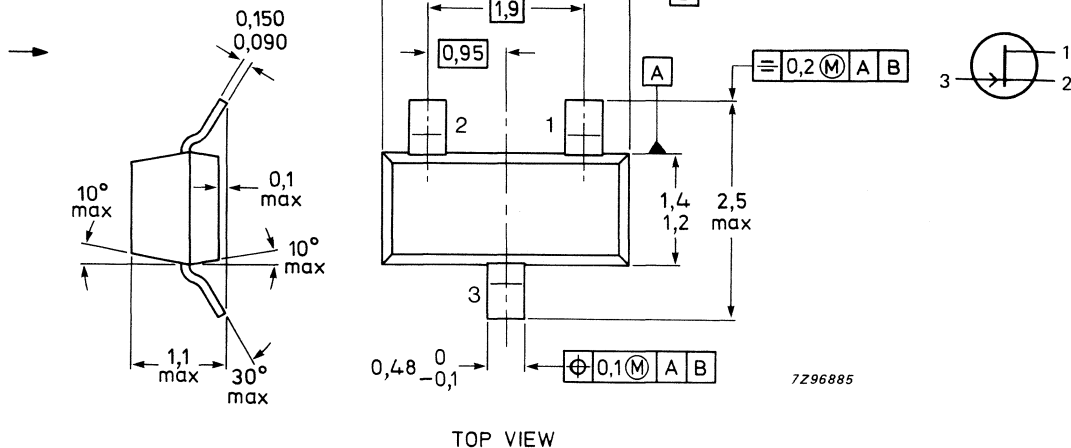

See also *Soldering recommendations*.

RATINGS

Limiting values in accordance with the Absolute Maximum System (IEC 134)

Drain-source voltage see Fig. 2	$\pm V_{DS}$	max.	25	V
Drain-gate voltage (open source) see Fig. 2	V_{DGO}	max.	25	V
Gate-source voltage (open drain) see Fig. 2	$-V_{GSO}$	max.	25	V
Drain current	I_D	max.	10	mA
Gate current	I_G	max.	5	mA
Total power dissipation up to $T_{amb} = 65\text{ }^\circ\text{C}^{**}$	P_{tot}	max.	250	mW
Storage temperature range	T_{stg}		-65 to + 175	$^\circ\text{C}$
Junction temperature	T_j	max.	175	$^\circ\text{C}$

THERMAL CHARACTERISTICS*

$$T_j = P \times (R_{th\ j-t} + R_{th\ t-s} + R_{th\ s-a}) + T_{amb}$$

Thermal resistance

From junction to tab	$R_{th\ j-t}$	=	60	K/W
From tab to soldering points	$R_{th\ t-s}$	=	280	K/W
From soldering points to ambient**	$R_{th\ s-a}$	=	90	K/W

CHARACTERISTICS

$T_j = 25\text{ }^\circ\text{C}$ unless otherwise specified

			BFR30	BFR31	
Gate cut-off current					
$-V_{GS} = 10\text{ V}; V_{DS} = 0$	$-I_{GSS}$	<	0,2	0,2	nA
Drain current					
$V_{DS} = 10\text{ V}; V_{GS} = 0$	I_{DSS}	>	4	1	mA
		<	10	5	mA
Gate-source voltage					
$I_D = 1\text{ mA}; V_{DS} = 10\text{ V}$	$-V_{GS}$	>	0,7	0	V
		<	3,0	1,3	V
$I_D = 50\text{ }\mu\text{A}; V_{DS} = 10\text{ V}$	$-V_{GS}$	<	4,0	2,0	V
Gate-source cut-off voltage					
$I_D = 0,5\text{ nA}; V_{DS} = 10\text{ V}$	$-V_{(P)GS}$	<	5	2,5	V
y parameters					
Transfer admittance at $f = 1\text{ kHz}; T_{amb} = 25\text{ }^\circ\text{C}$					
$I_D = 1\text{ mA}; V_{DS} = 10\text{ V}$	$ Y_{fs} $	>	1,0	1,5	mS
		<	4,0	4,5	mS
$I_D = 200\text{ }\mu\text{A}; V_{DS} = 10\text{ V}$	$ Y_{fs} $	>	0,5	0,75	mS
Output admittance at $f = 1\text{ kHz}$					
$I_D = 1\text{ mA}; V_{DS} = 10\text{ V}$	$ Y_{os} $	<	40	25	μS
$I_D = 200\text{ }\mu\text{A}; V_{DS} = 10\text{ V}$	$ Y_{os} $	<	20	15	μS

* See *Thermal characteristics*.

** Mounted on a ceramic substrate of 8 mm x 10 mm x 0,7 mm.

y parameters (continued)

		BFR30	BFR31	
Input capacitance at $f = 1 \text{ MHz}$				
$I_D = 1 \text{ mA}; V_{DS} = 10 \text{ V}$	C_{is}	< 4	4	pF
$I_D = 200 \mu\text{A}; V_{DS} = 10 \text{ V}$	C_{is}	< 4	4	pF
Feedback capacitance at $f = 1 \text{ MHz}; T_{amb} = 25 \text{ }^\circ\text{C}$				
$I_D = 1 \text{ mA}; V_{DS} = 10 \text{ V}$	C_{rs}	< 1,5	1,5	pF
$I_D = 200 \mu\text{A}; V_{DS} = 10 \text{ V}$	C_{rs}	< 1,5	1,5	pF
Equivalent noise voltage				
$I_D = 200 \mu\text{A}; V_{DS} = 10 \text{ V}$				
$B = 0,6 \text{ to } 100 \text{ Hz}$	V_n	< 0,5	0,5	μV

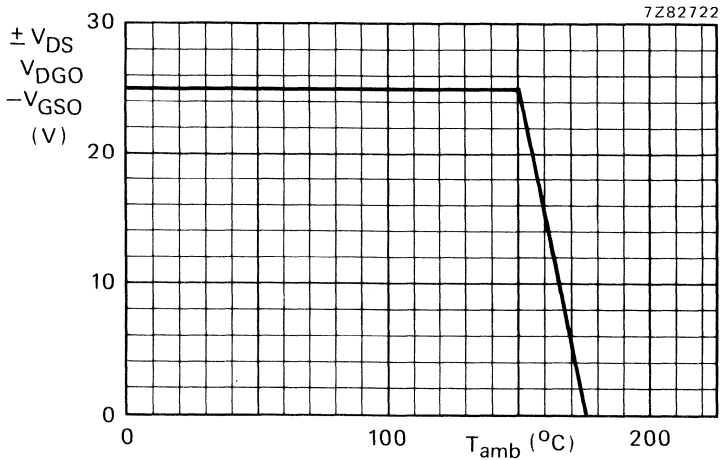

Fig. 2 Voltage derating curve.

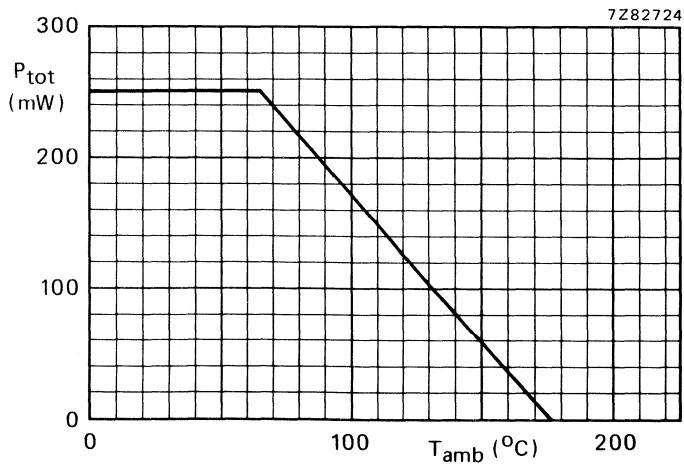

Fig. 3 Power derating curve.

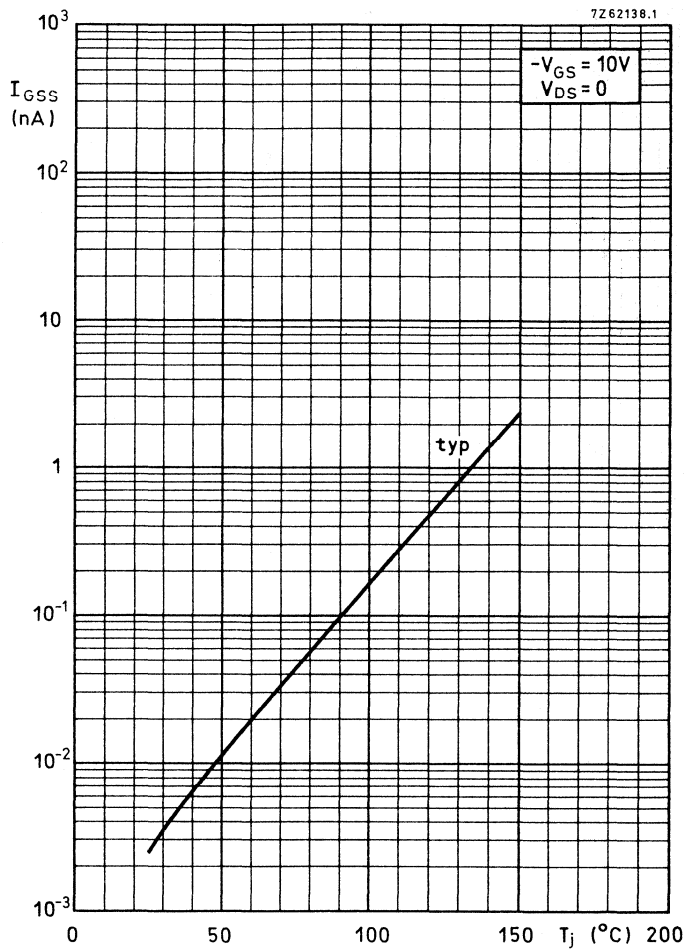

Fig. 4.

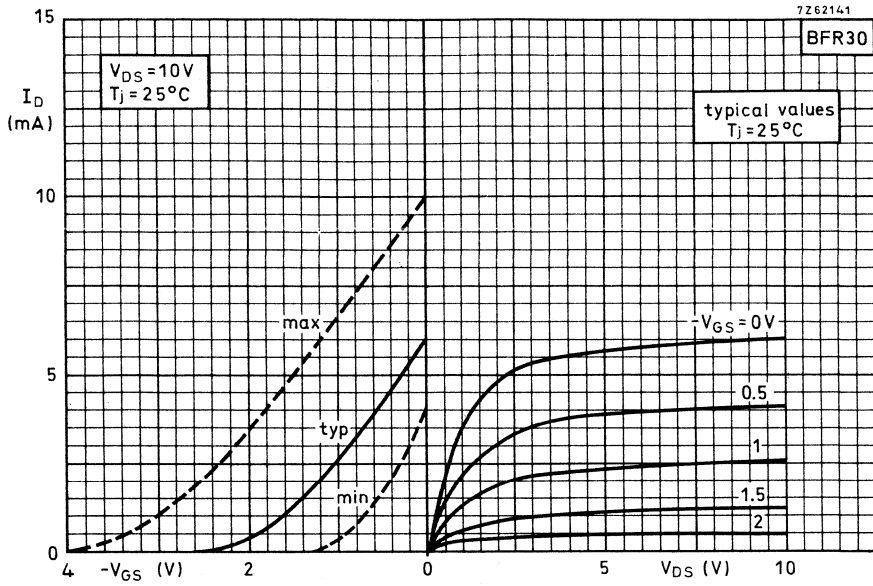

Fig. 5.

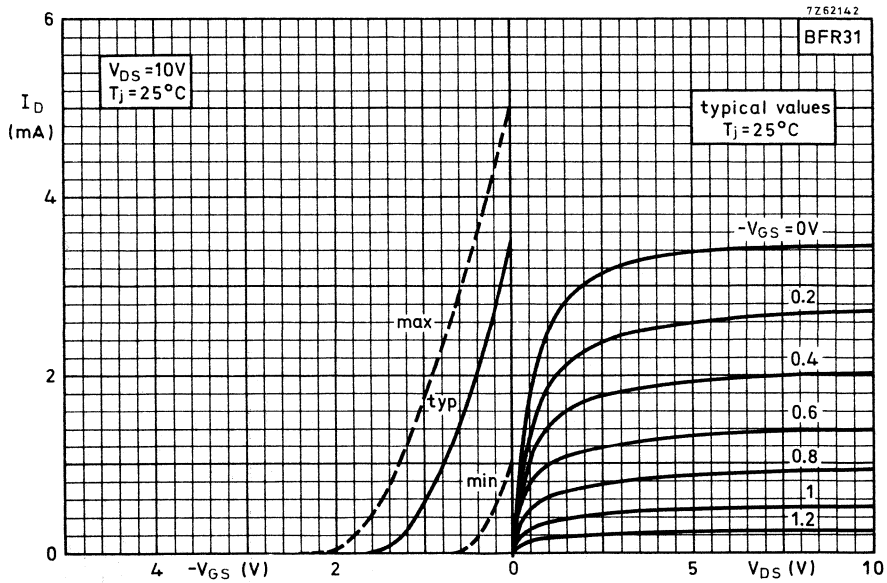

Fig. 6.

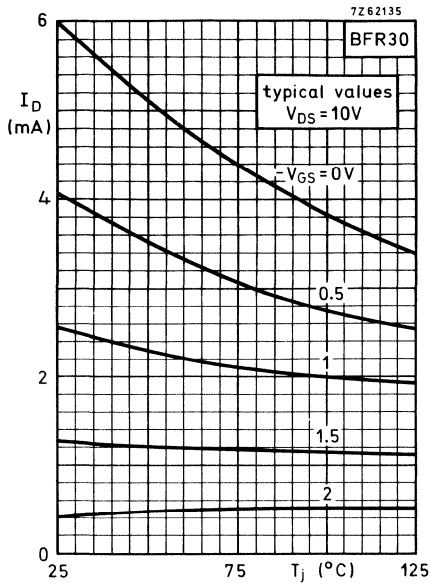

Fig. 7.

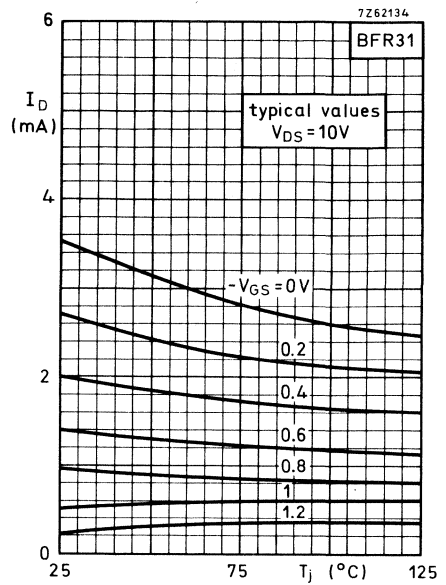

Fig. 8.

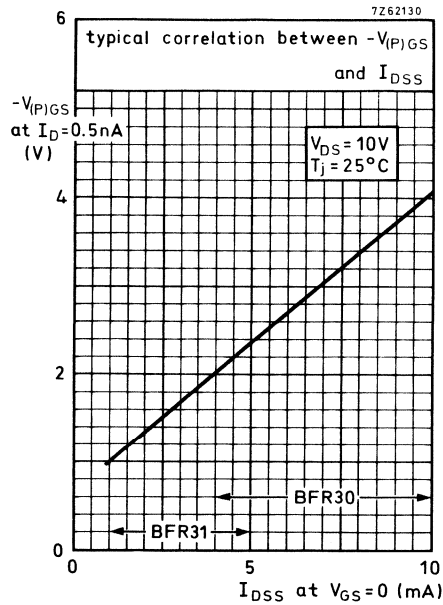

Fig. 9.

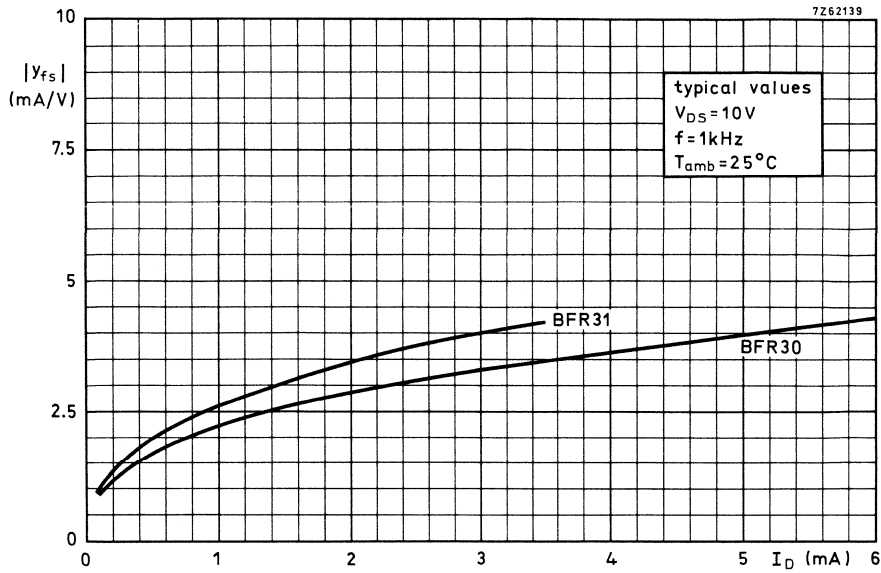

Fig. 10.

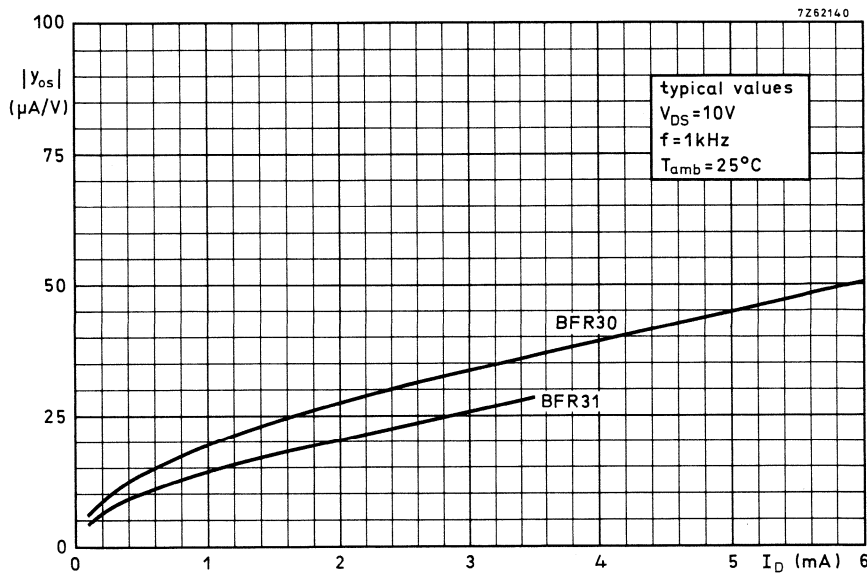

Fig. 11.

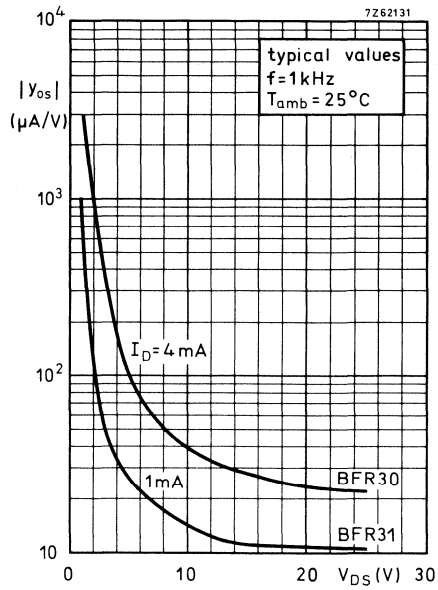

Fig. 12.

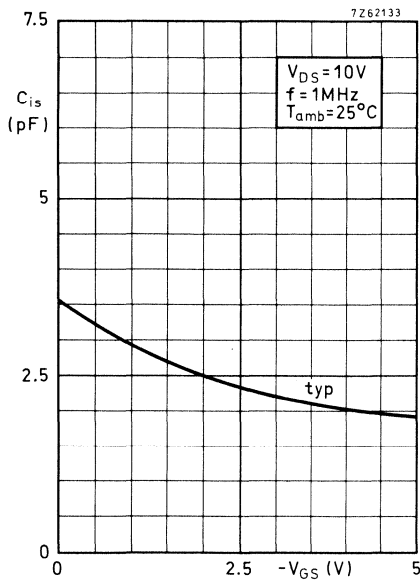

Fig. 13.

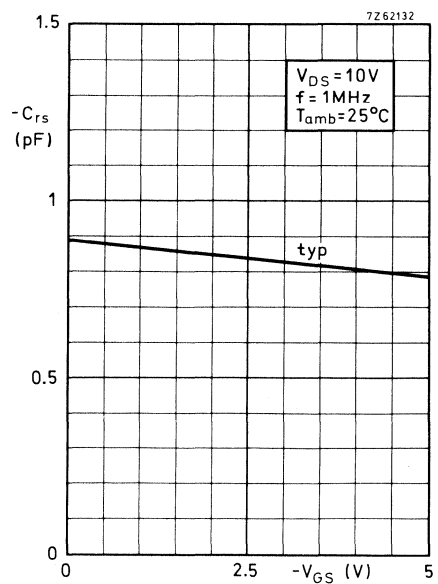

Fig. 14.

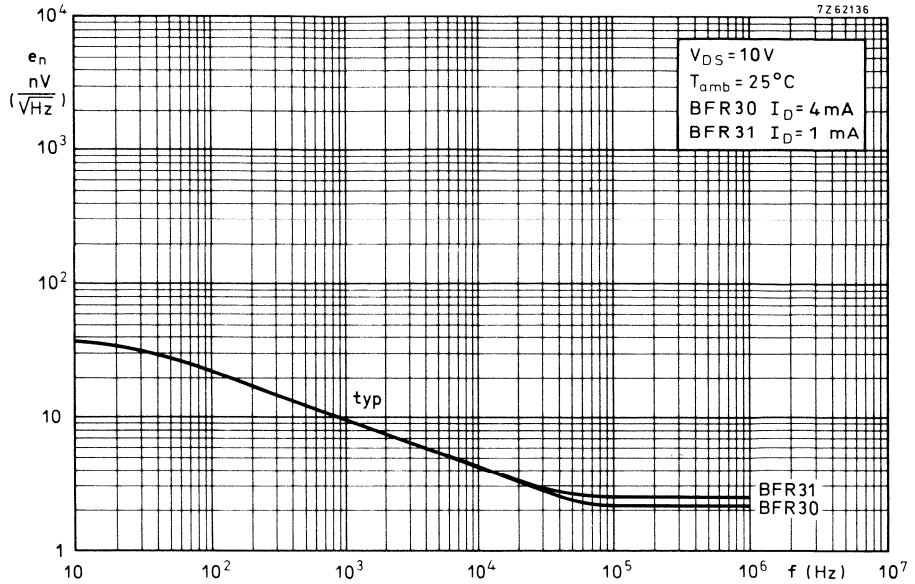

Fig. 15.

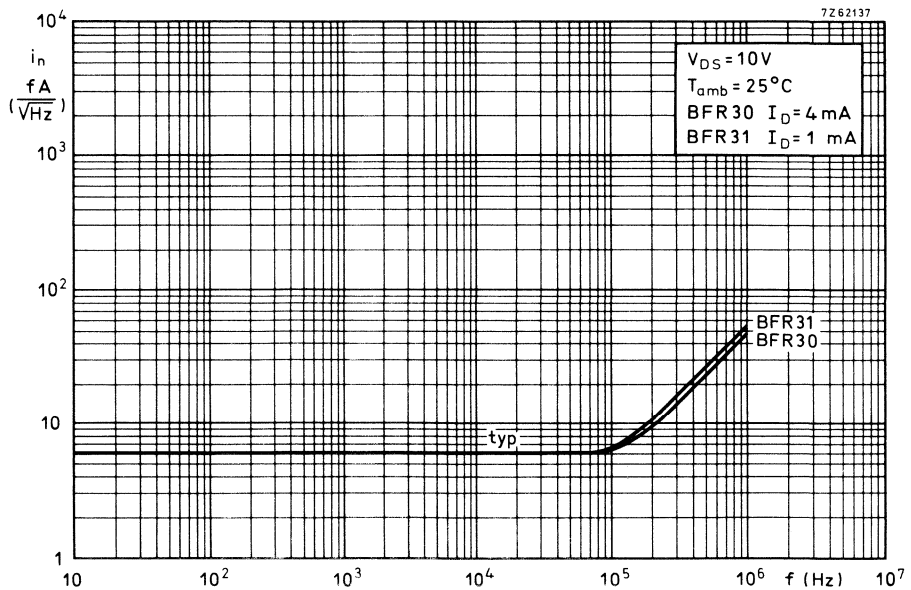

Fig. 16.

N-P-N H.F. WIDEBAND TRANSISTOR

N-P-N multi-emitter transistor in a plastic SOT-23 envelope intended for application in thick and thin-film circuits. The transistor has very low intermodulation distortion and very high power gain. It is primarily intended for:

- Wideband vertical amplifiers in high speed oscilloscopes.
- Television distribution amplifiers.

QUICK REFERENCE DATA

Collector-base voltage (open emitter)	V_{CBO}	max.	18 V
Collector-emitter voltage (open base)	V_{CEO}	max.	10 V
Collector current (peak value; $f > 1$ MHz)	I_{CM}	max.	100 mA
Total power dissipation up to $T_{amb} = 65$ °C	P_{tot}	max.	250 mW
Junction temperature	T_j	max.	175 °C
Feedback capacitance at $f = 1$ MHz $I_C = 2$ mA; $V_{CE} = 5$ V	C_{re}	typ.	0,9 pF
Transition frequency at $f = 500$ MHz $I_C = 25$ mA; $V_{CE} = 5$ V	f_T	typ.	2,0 GHz
Max. unilateral power gain $I_C = 30$ mA; $V_{CE} = 5$ V; $f = 200$ MHz	GUM	typ.	22 dB
$I_C = 30$ mA; $V_{CE} = 5$ V; $f = 800$ MHz	GUM	typ.	10,5 dB
Intermodulation distortion at $T_{amb} = 25$ °C $I_C = 30$ mA; $V_{CE} = 5$ V; $R_L = 37,5$ Ω $V_O = 100$ mV at $f_p = 183$ MHz $V_O = 100$ mV at $f_q = 200$ MHz measured at $f_{(2q-p)} = 217$ MHz	dim	typ.	-60 dB

MECHANICAL DATA

Dimensions in mm

Fig. 1 SOT-23.

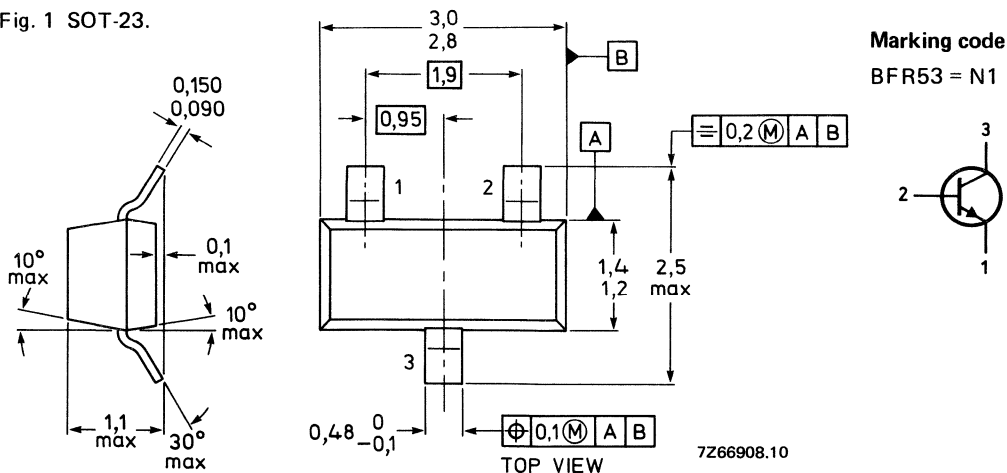

If required, the R-version (reverse pinning) is available on request.

RATINGS

Limiting values in accordance with the Absolute Maximum System (IEC 134)

Collector-base voltage (open emitter) see Fig. 3	V_{CBO}	max.	18 V
Collector-emitter voltage (open base) see Fig. 3	V_{CEO}	max.	10 V
Emitter-base voltage (open collector) see Fig. 3	V_{EBO}	max.	2,5 V
Collector current (d.c.)	I_C	max.	50 mA
Collector current (peak value: $f > 1$ MHz)	I_{CM}	max.	100 mA
Total power dissipation up to $T_{amb} = 65$ °C**	P_{tot}	max.	250 mW
Storage temperature	T_{stg}		-65 to +175 °C
Junction temperature	T_j	max.	175 °C

THERMAL RESISTANCE *

From junction to ambient**

$$R_{th\ j-a} = 430\ K/W$$

CHARACTERISTICS $T_j = 25$ °C unless otherwise specified

Collector cut-off current

$$I_E = 0; V_{CB} = 10\ V$$

$$I_{CBO} \text{ max. } 50\ nA$$

D.C. current gain

$$I_C = 25\ mA; V_{CE} = 5\ V$$

$$h_{FE} \text{ min. } 25$$

$$I_C = 50\ mA; V_{CE} = 5\ V$$

$$h_{FE} \text{ min. } 25$$

Transition frequency at $f = 500$ MHz

$$I_C = 25\ mA; V_{CE} = 5\ V$$

$$f_T \text{ typ. } 2,0\ GHz$$

Collector capacitance at $f = 1$ MHz

$$I_E = I_e = 0; V_{CB} = 5\ V$$

$$C_c \text{ typ. } 0,9\ pF$$

Emitter capacitance at $f = 1$ MHz

$$I_C = I_c = 0; V_{EB} = 0,5\ V$$

$$C_e \text{ typ. } 1,5\ pF$$

Feedback capacitance at $f = 1$ MHz

$$I_C = 2\ mA; V_{CE} = 5\ V; T_{amb} = 25\ ^\circ C$$

$$C_{re} \text{ typ. } 0,9\ pF$$

* See *Thermal characteristics*.

** Mounted on a ceramic substrate of 8 mm x 10 mm x 0,7 mm.

Noise figure at f = 500 MHz ▲

$I_C = 2 \text{ mA}; V_{CE} = 5 \text{ V}; T_{amb} = 25 \text{ }^\circ\text{C}$
 $G_S = 20 \text{ mS}; B_S \text{ is tuned}$

F max. 5,0 dB

Max. unilateral power gain (s_{re} assumed to be zero)

$$G_{UM} = 10 \log \frac{|s_{fe}|^2}{[1 - |s_{ie}|^2][1 - |s_{oe}|^2]}$$

$I_C = 30 \text{ mA}; V_{CE} = 5 \text{ V}; f = 200 \text{ MHz}; T_{amb} = 25 \text{ }^\circ\text{C}$
 $I_C = 30 \text{ mA}; V_{CE} = 5 \text{ V}; f = 800 \text{ MHz}; T_{amb} = 25 \text{ }^\circ\text{C}$

G_{UM} typ. 22 dB
 G_{UM} typ. 10,5 dB

Intermodulation distortion ▲

$I_C = 30 \text{ mA}; V_{CE} = 5 \text{ V}; R_L = 37,5 \text{ } \Omega$

$V_o = 100 \text{ mV}$ at $f_p = 183 \text{ MHz}$

$V_o = 100 \text{ mV}$ at $f_q = 200 \text{ MHz}$

measured at $f(2q-p) = 217 \text{ MHz}$

d_{im} typ. -60 dB

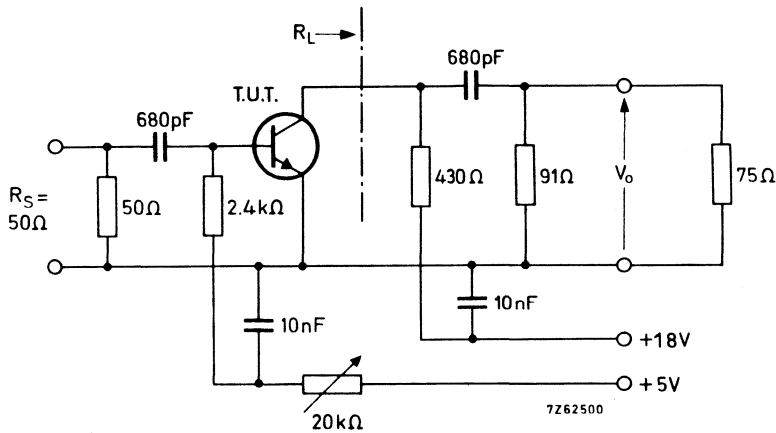

Fig. 2 Test circuit.

▲ Crystal mounted in a BFW30 envelope.

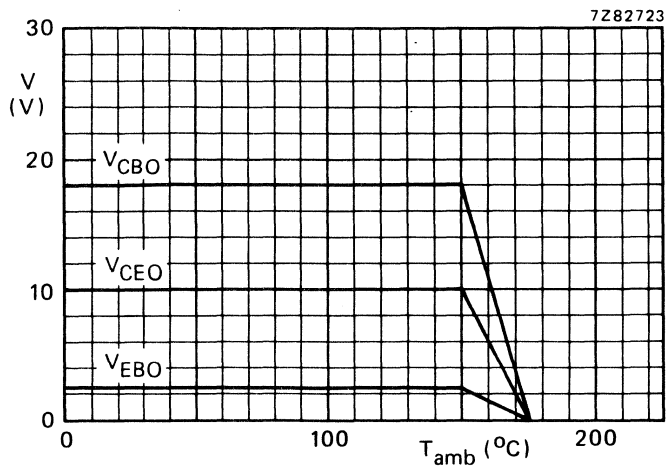

Fig. 3 Voltage derating curves.

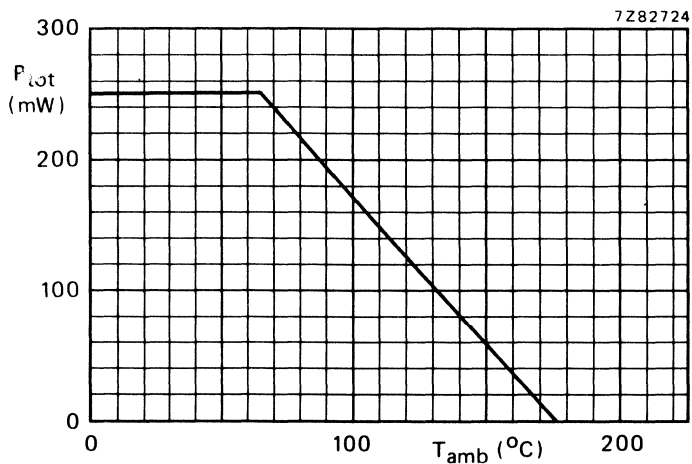

Fig. 4 Power derating curve.

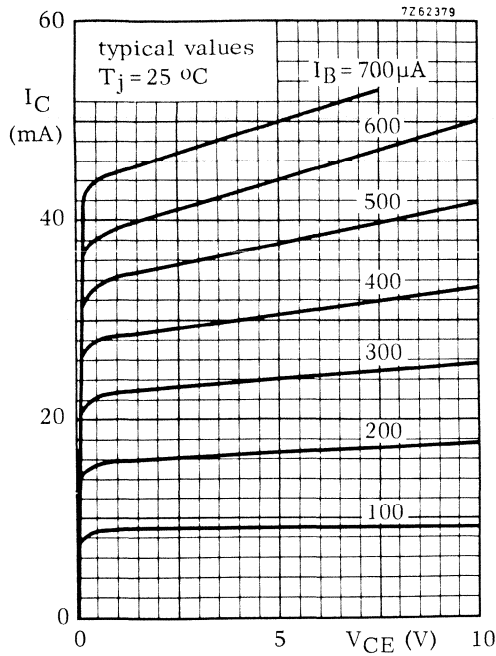

Fig. 5 $T_j = 25\text{ }^\circ\text{C}$; typical values.

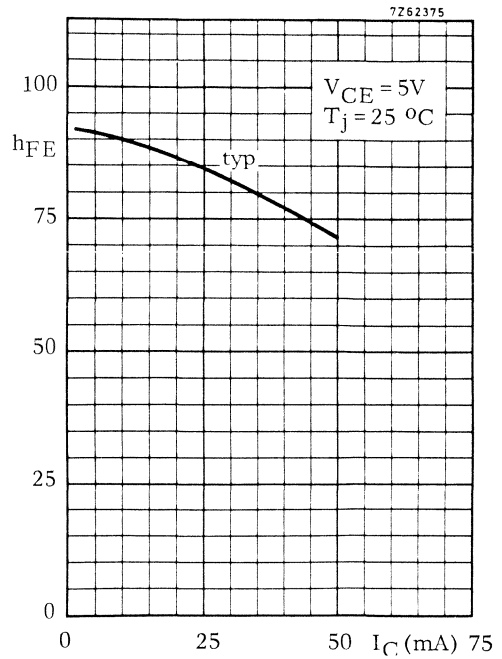

Fig. 6 $V_{CE} = 5\text{ V}$; $T_j = 25\text{ }^\circ\text{C}$; typical values.

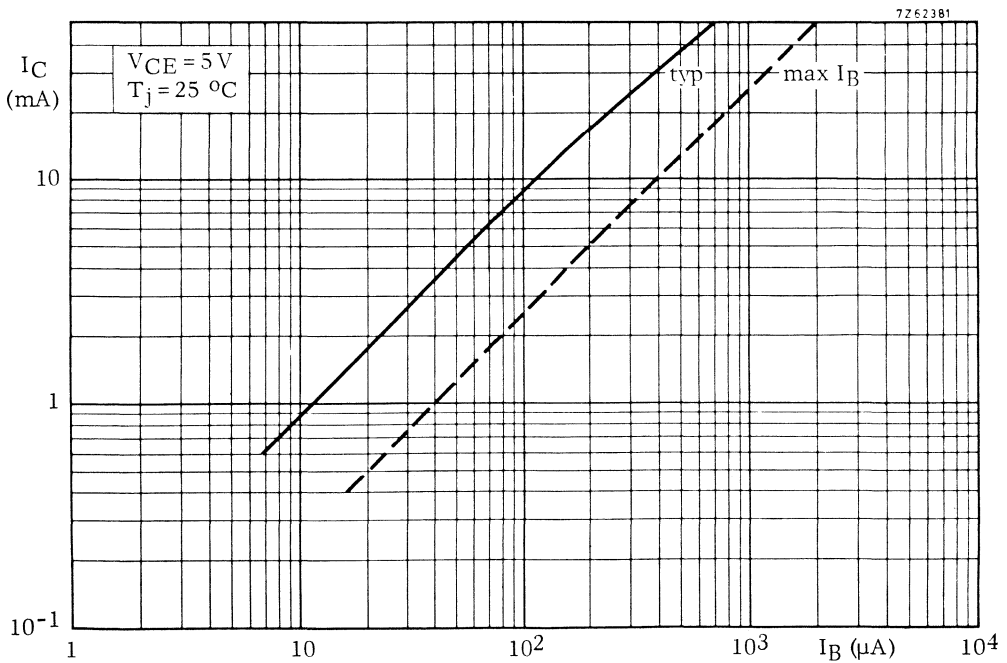

Fig. 7 $V_{CE} = 5\text{ V}$; $T_j = 25\text{ }^\circ\text{C}$.

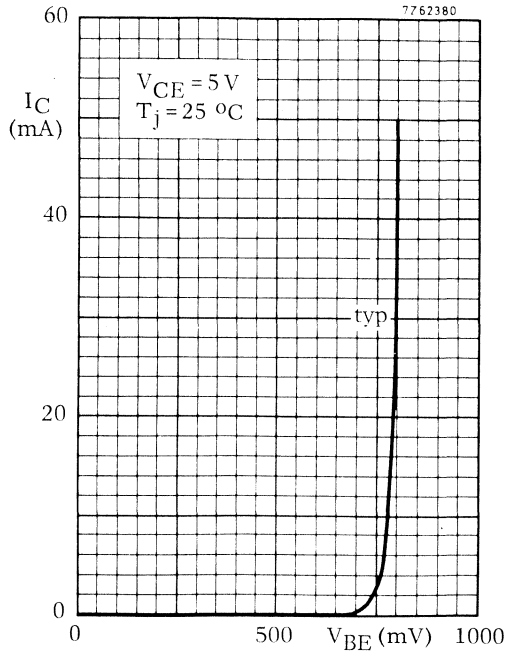

Fig. 8 $V_{CE} = 5\text{ V}$; $T_j = 25\text{ }^\circ\text{C}$; typical values.

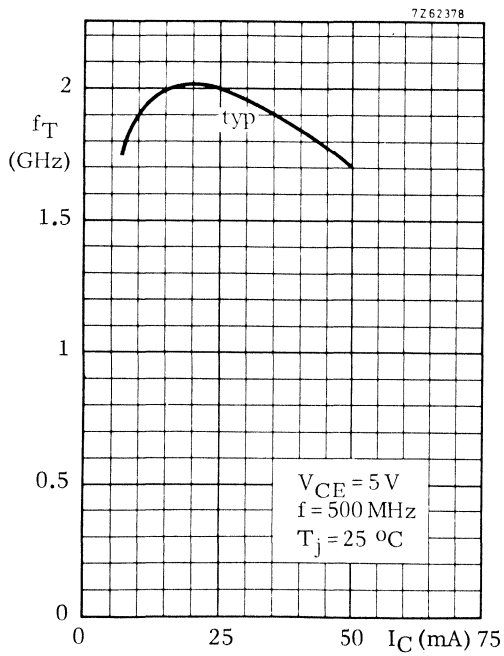

Fig. 9 $V_{CE} = 5\text{ V}$; $f = 500\text{ MHz}$;
 $T_j = 25\text{ }^\circ\text{C}$; typical values.

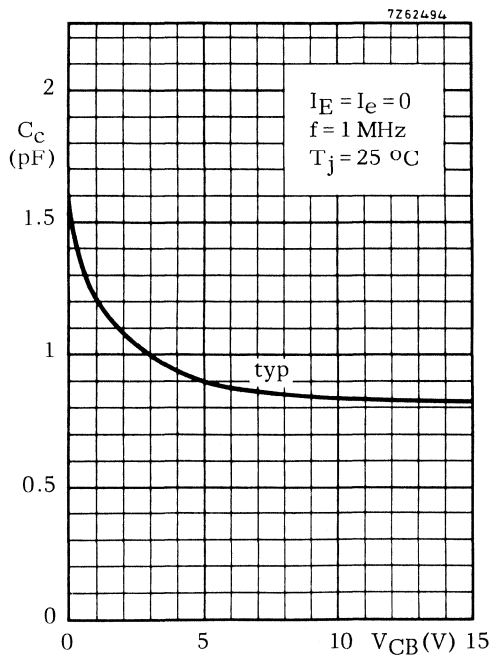

Fig. 10 $I_E = I_e = 0$; $f = 1\text{ MHz}$;
 $T_j = 25\text{ }^\circ\text{C}$; typical values.

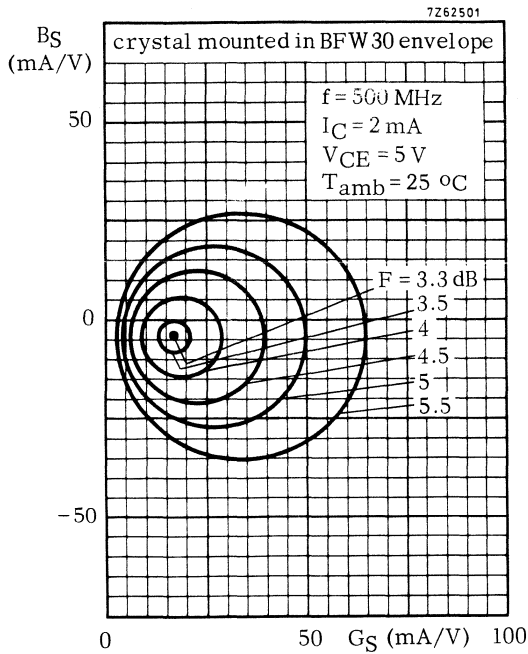

Fig. 11 Circles of constant noise figure; $V_{CE} = 5\text{ V}$; $I_C = 2\text{ mA}$; $f = 500\text{ MHz}$; $T_{amb} = 25\text{ }^\circ\text{C}$; typ. values.

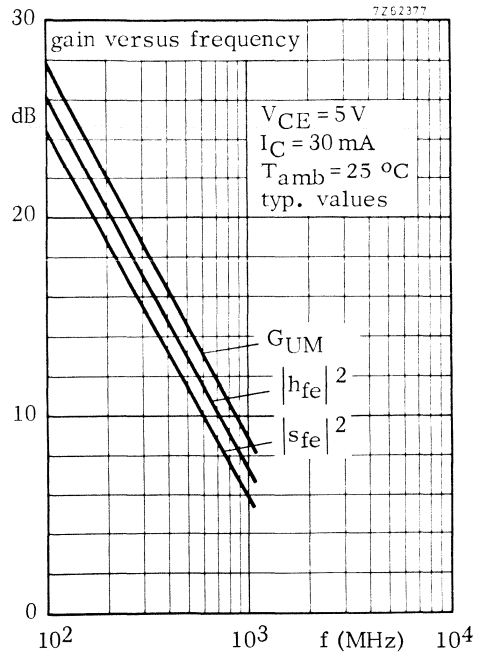

Fig. 12 $V_{CE} = 5\text{ V}$; $I_C = 30\text{ mA}$; $T_{amb} = 25\text{ }^\circ\text{C}$; typical values.

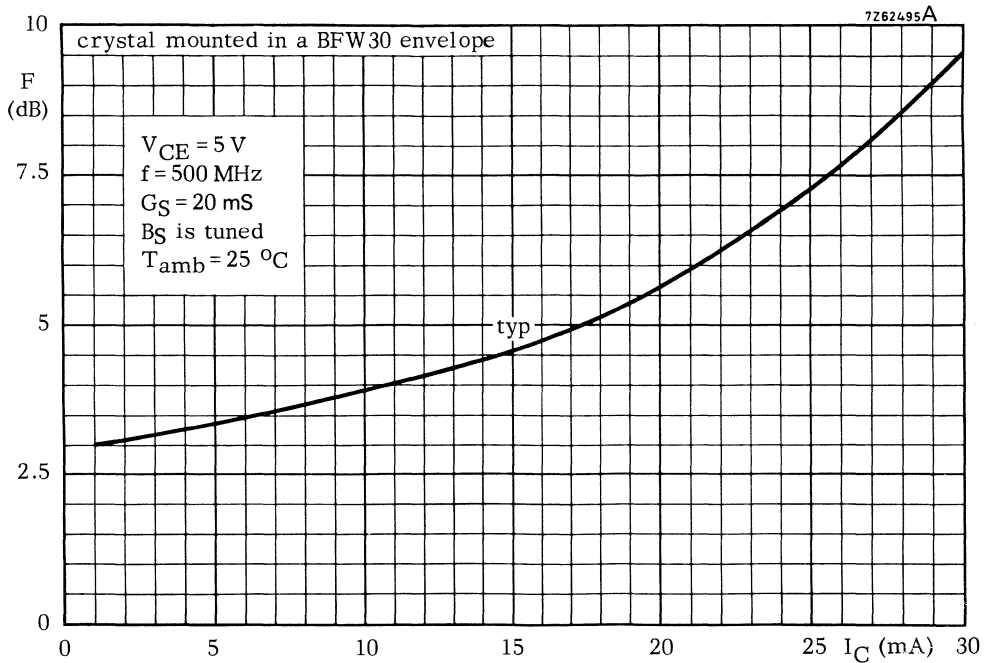

Fig. 13 $V_{CE} = 5\text{ V}$; $f = 500\text{ MHz}$; $G_S = 20\text{ mS}$; $B_S = \text{tuned}$; $T_{amb} = 25\text{ }^\circ\text{C}$; typical values.

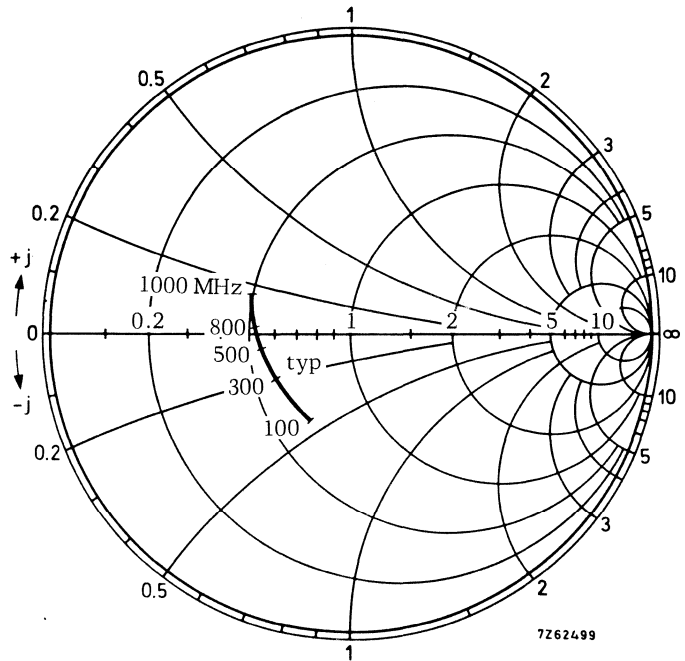

Fig. 14 $V_{CE} = 5\text{ V}$; $I_C = 30\text{ mA}$;
 $T_{amb} = 25\text{ }^\circ\text{C}$; typical values.

Input impedance derived from
 input reflection coefficient s_{ie}
 coordinates in ohm $\times 50$.

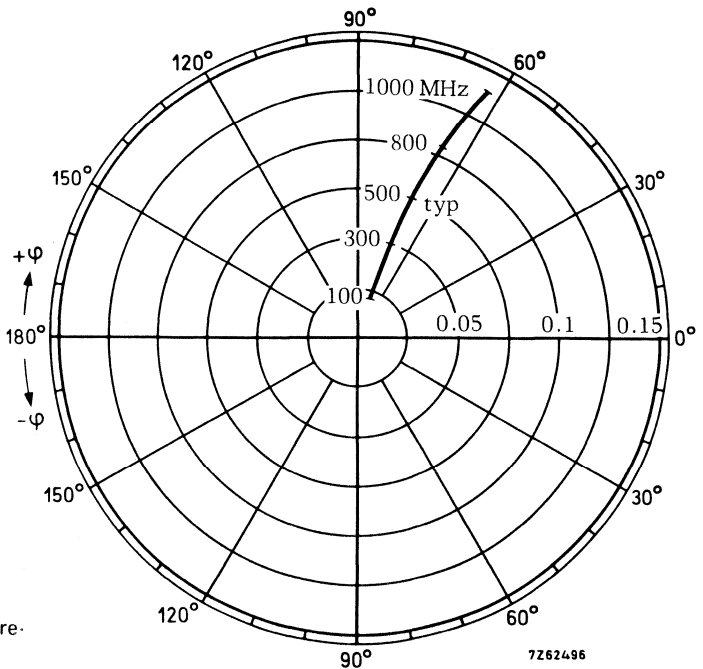
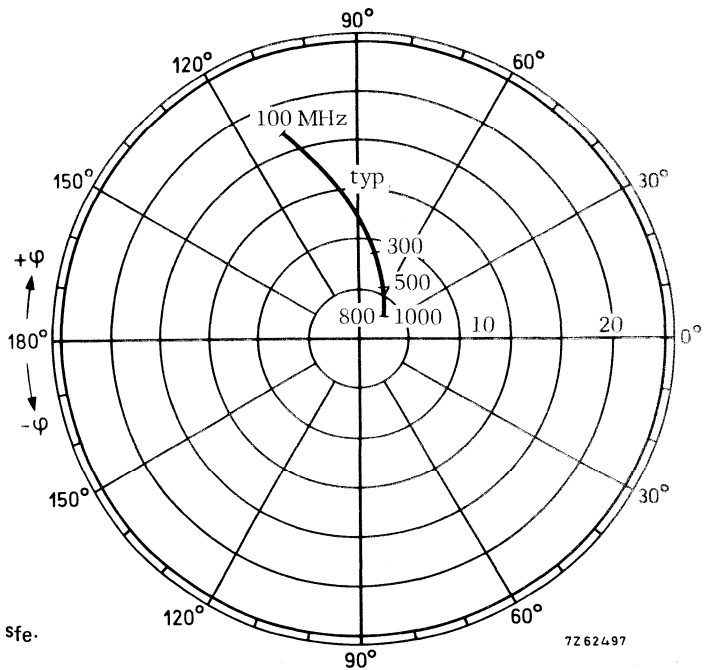
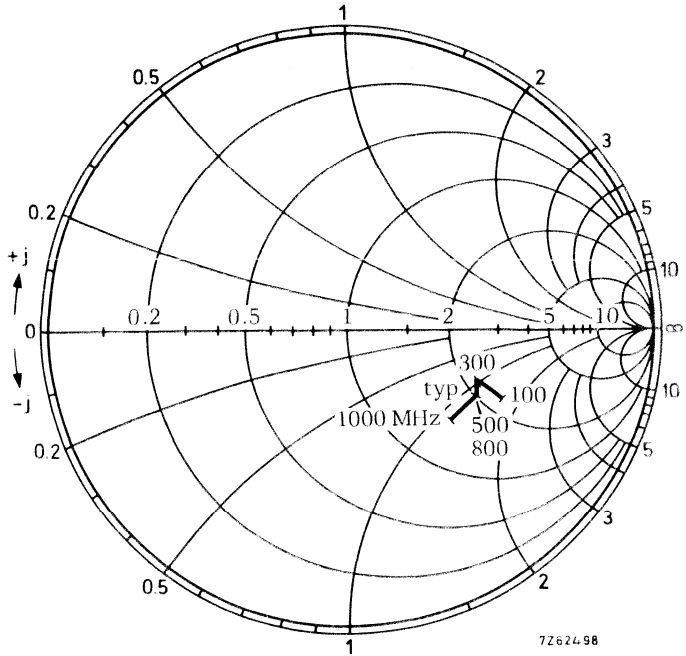

Fig. 15 $V_{CE} = 5\text{ V}$; $I_C = 30\text{ mA}$;
 $T_{amb} = 25\text{ }^\circ\text{C}$; typical values.

Reverse transmission coefficient s_{re} .



N-P-N 1 GHz WIDEBAND TRANSISTOR

N-P-N transistor in a plastic SOT-23 envelope. It is primarily intended for use in u.h.f. and microwave amplifiers in thick and thin-film circuits, such as in aerial amplifiers, radar systems, oscilloscopes, spectrum analysers etc. The transistor features low intermodulation distortion and high power gain; thanks to its very high transition frequency, it also has excellent wideband properties and low noise up to high frequencies.

P-N-P complement is BFT92.

QUICK REFERENCE DATA

Collector-base voltage (open emitter)	V_{CB0}	max.	20 V
Collector-emitter voltage (open base)	V_{CEO}	max.	15 V
Collector current (d.c.)	I_C	max.	25 mA
Total power dissipation up to $T_{amb} = 60\text{ }^\circ\text{C}$	P_{tot}	max.	200 mW
Junction temperature	T_j	max.	150 $^\circ\text{C}$
Transition frequency at $f = 500\text{ MHz}$ $I_C = 14\text{ mA}; V_{CE} = 10\text{ V}$	f_T	typ.	5,0 GHz
Feedback capacitance at $f = 1\text{ MHz}$ $I_C = 2\text{ mA}; V_{CE} = 10\text{ V}$	C_{re}	typ.	0,4 pF
Noise figure at optimum source impedance $I_C = 2\text{ mA}; V_{CE} = 10\text{ V}; f = 500\text{ MHz}$	F	typ.	2,4 dB
Max. unilateral power gain $I_C = 14\text{ mA}; V_{CE} = 10\text{ V}; f = 500\text{ MHz}$	GUM	typ.	18,0 dB
Output voltage at $d_{im} = -60\text{ dB}$ (see Fig. 2) $I_C = 14\text{ mA}; V_{CE} = 10\text{ V}; R_L = 75\text{ }\Omega; T_{amb} = 25\text{ }^\circ\text{C}$ $f_{(p+q-r)} = 493,25\text{ MHz}$	V_o	typ.	150 mV

MECHANICAL DATA

Fig. 1 SOT-23.

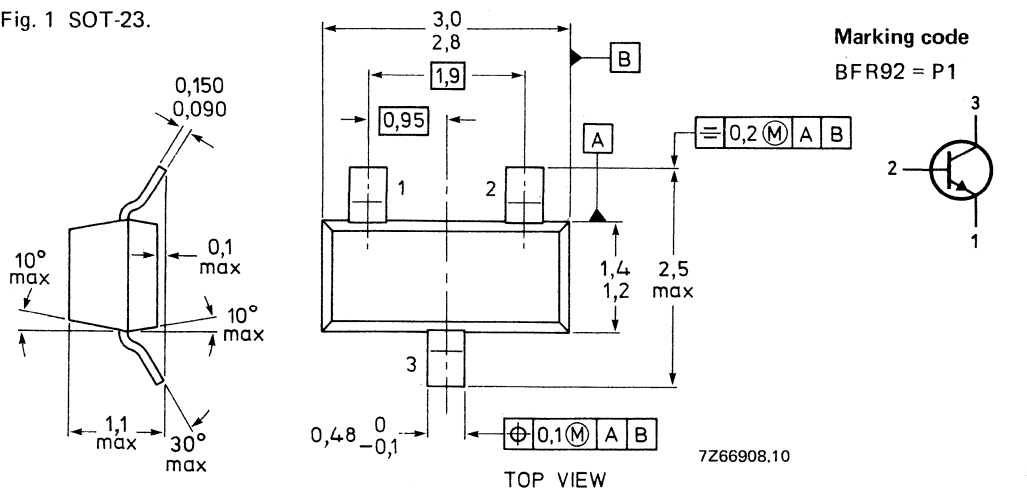

If required, the R-version (reverse pinning) is available on request.

RATINGS

Limiting values in accordance with the Absolute Maximum System (IEC 134)

Collector-base voltage (open emitter)	V_{CB0}	max.	20 V
Collector-emitter voltage (open base)	V_{CEO}	max.	15 V
Emitter-base voltage (open collector)	V_{EBO}	max.	2 V
Collector current (d.c.)	I_C	max.	25 mA
Total power dissipation up to $T_{amb} = 60\text{ }^\circ\text{C}^{**}$	P_{tot}	max.	200 mW
Storage temperature	T_{stg}		-65 to +150 $^\circ\text{C}$
Junction temperature	T_j	max.	150 $^\circ\text{C}$

THERMAL RESISTANCE*

From junction to ambient**	$R_{th\ j-a}$	=	430 K/W
----------------------------	---------------	---	---------

CHARACTERISTICS $T_j = 25\text{ }^\circ\text{C}$ unless otherwise specified

Collector cut-off current

$I_E = 0; V_{CB} = 10\text{ V}$

I_{CBO}	max.	50 nA
-----------	------	-------

D.C. current gain

$I_C = 14\text{ mA}; V_{CE} = 10\text{ V}$

h_{FE}	min.	25
	typ.	50

Transition frequency at $f = 500\text{ MHz}$

$I_C = 14\text{ mA}; V_{CE} = 10\text{ V}$

f_T	typ.	5,0 GHz
-------	------	---------

Collector capacitance at $f = 1\text{ MHz}$

$I_E = I_e = 0; V_{CB} = 10\text{ V}$

C_c	typ.	0,75 pF
-------	------	---------

Emitter capacitance at $f = 1\text{ MHz}$

$I_C = I_c = 0; V_{EB} = 0,5\text{ V}$

C_e	typ.	0,8 pF
-------	------	--------

Feedback capacitance at $f = 1\text{ MHz}$

$I_C = 2\text{ mA}; V_{CE} = 10\text{ V}; T_{amb} = 25\text{ }^\circ\text{C}$

C_{re}	typ.	0,4 pF
----------	------	--------

* See *Thermal characteristics*.

** Mounted on a ceramic substrate of 8 mm x 10 mm x 0,7 mm.

Noise figure at optimum source impedance*

$I_C = 2 \text{ mA}; V_{CE} = 10 \text{ V}; f = 500 \text{ MHz}; T_{amb} = 25 \text{ }^\circ\text{C}$

F typ. 2,4 dB

Max. unilateral power gain (s_{re} assumed to be zero)

$$G_{UM} = 10 \log \frac{|s_{fe}|^2}{[1 - |s_{ie}|^2][1 - |s_{oe}|^2]}$$

$I_C = 14 \text{ mA}; V_{CE} = 10 \text{ V}; f = 500 \text{ MHz}; T_{amb} = 25 \text{ }^\circ\text{C}$

G_{UM} typ. 18,0 dB

Output voltage at $d_{im} = -60 \text{ dB}$ (see Fig. 2)

(DIN 45004B; par. 6.3.: 3-tone)

$I_C = 14 \text{ mA}; V_{CE} = 10 \text{ V}; R_L = 75 \text{ } \Omega$

$V_p = V_o$ at $d_{im} = -60 \text{ dB}; f_p = 495,25 \text{ MHz}$

$V_q = V_o - 6 \text{ dB}; f_q = 503,25 \text{ MHz}$

$V_r = V_o - 6 \text{ dB}; f_r = 505,25 \text{ MHz}$

measured at $f_{(p+q-r)} = 493,25 \text{ MHz}$

V_o typ. 150 mV

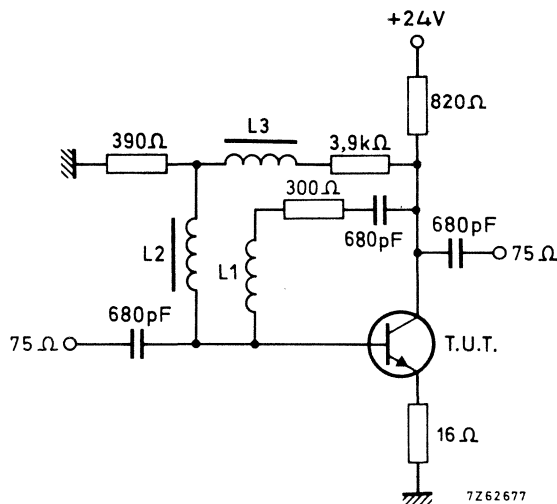

Fig. 2 Intermodulation test circuit.

L1 = 4 turns Cu wire (0,35 mm); winding pitch 1 mm; int. dia. 4 mm

L2 = L3 = 5 μH (code number: 3122 108 20150)

* Crystal mounted in a BFR90 envelope.

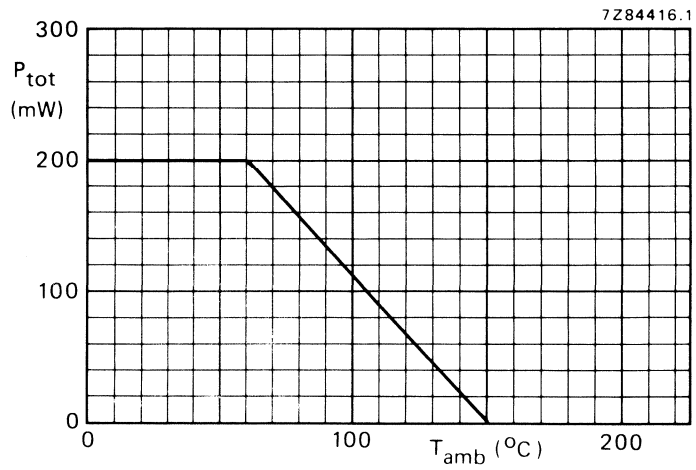

Fig. 3 Power derating curve.

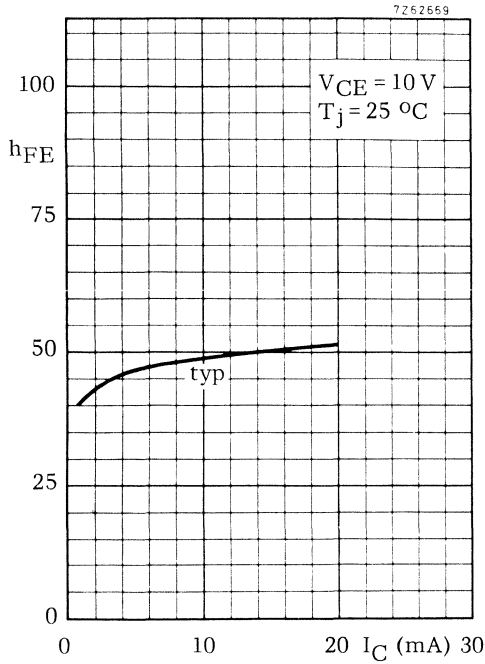

Fig. 4 $V_{CE} = 10\text{ V}$; $T_j = 25\text{ }^\circ\text{C}$; typical values.

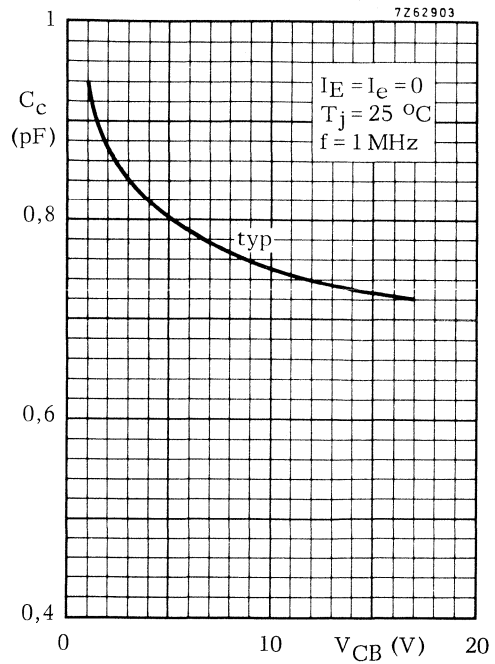

Fig. 5 $I_E = I_e = 0$; $f = 1\text{ MHz}$; $T_j = 25\text{ }^\circ\text{C}$; typical values.

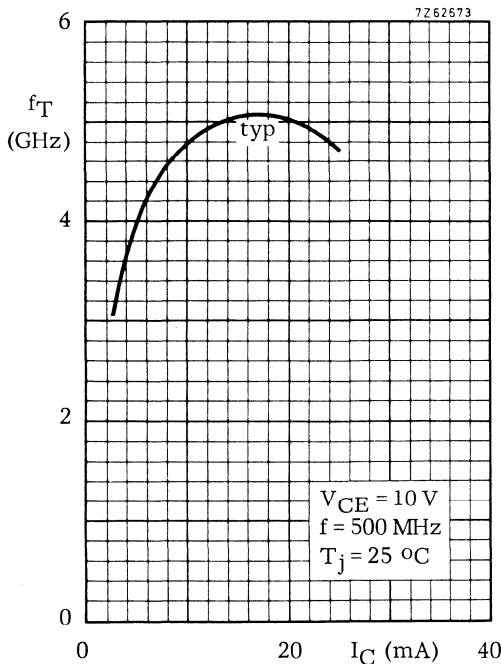

Fig. 6 $V_{CE} = 10\text{ V}$; $f = 500\text{ MHz}$; $T_j = 25\text{ }^\circ\text{C}$; typical values.

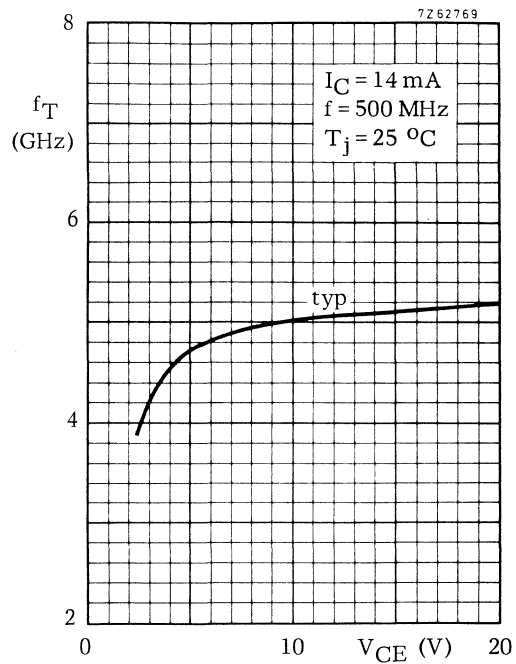

Fig. 7 $I_C = 14\text{ mA}$; $f = 500\text{ MHz}$; $T_j = 25\text{ }^\circ\text{C}$; typical values.

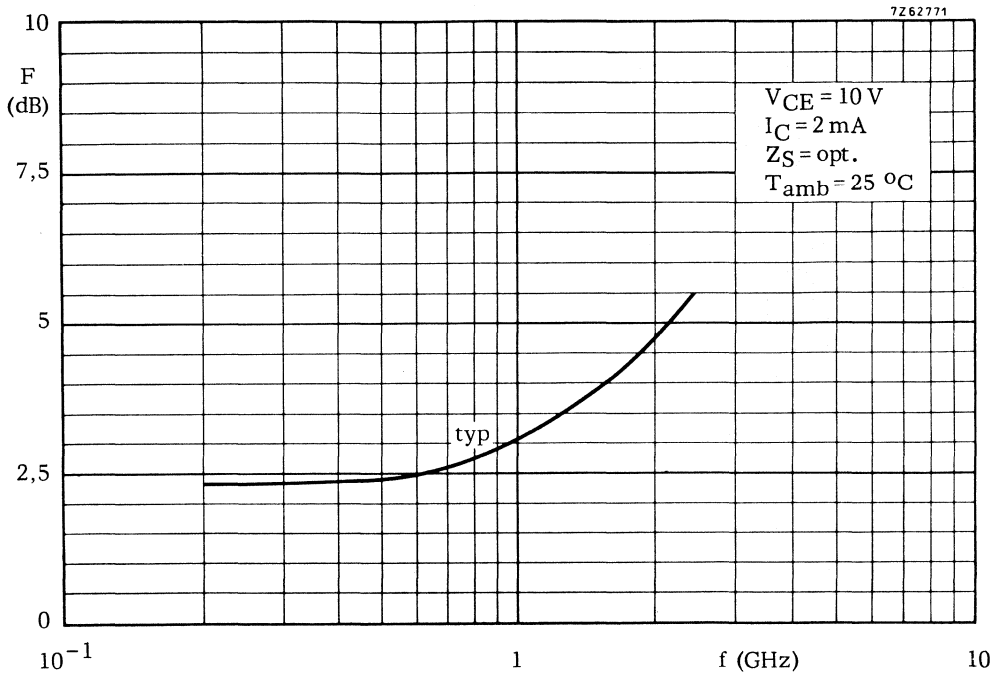

Fig. 8 $V_{CE} = 10 \text{ V}$; $I_C = 2 \text{ mA}$; $Z_S = \text{opt.}$; $T_{\text{amb}} = 25 \text{ }^\circ\text{C}$; typical values.

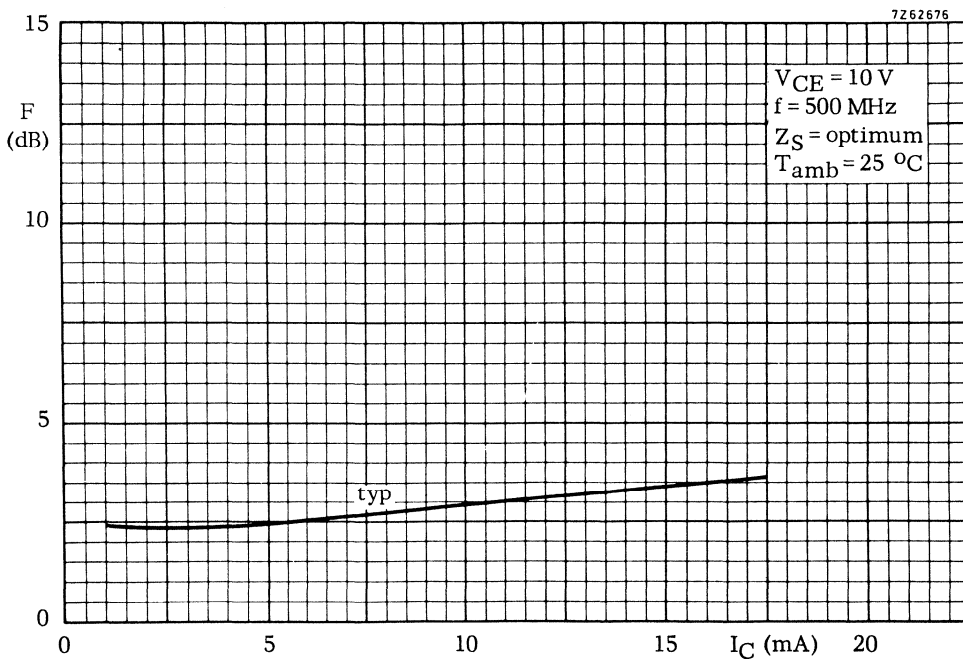

Fig. 9 $V_{CE} = 10 \text{ V}$; $f = 500 \text{ MHz}$; $Z_S = \text{opt.}$; $T_{\text{amb}} = 25 \text{ }^\circ\text{C}$; typical values.

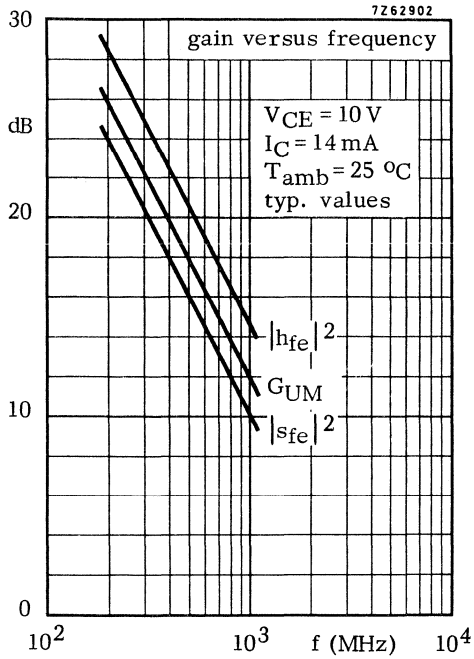

Fig. 10 $V_{CE} = 10\text{ V}$; $I_C = 14\text{ mA}$; $T_{amb} = 25\text{ }^\circ\text{C}$; typical values.

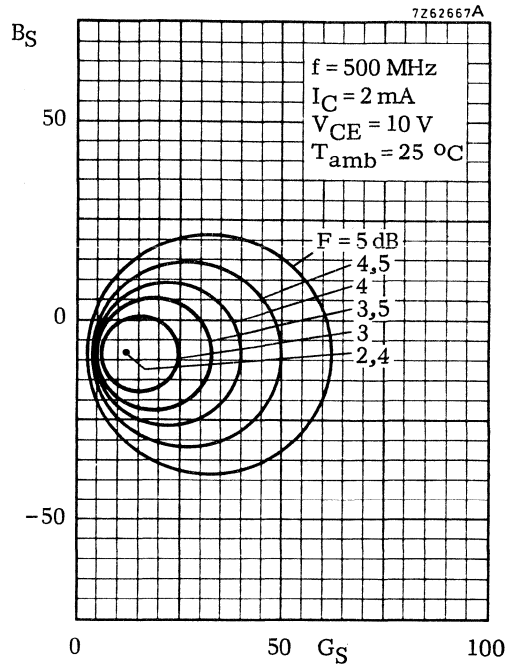

Fig. 11 Circles of constant noise figure; $V_{CE} = 10\text{ V}$; $I_C = 2\text{ mA}$; $f = 500\text{ MHz}$; $T_{amb} = 25\text{ }^\circ\text{C}$; typical values.

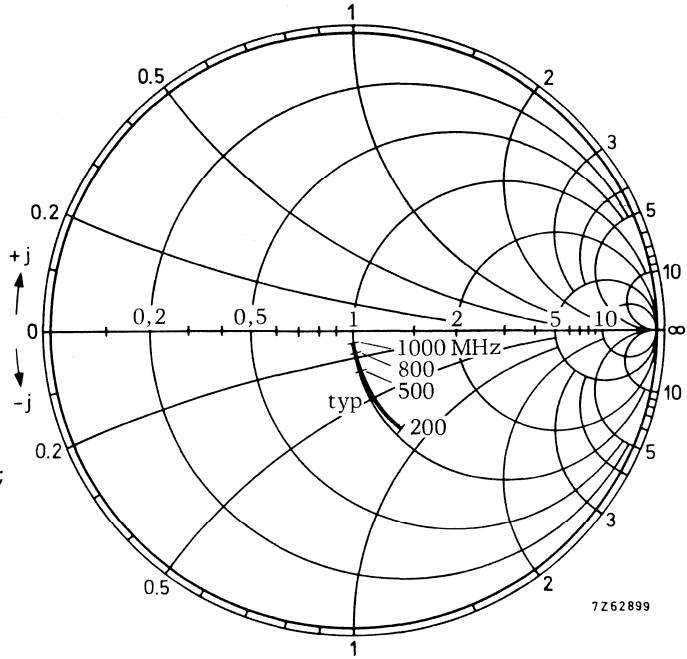

Fig. 12 $V_{CE} = 10\text{ V}$; $I_C = 14\text{ mA}$;
 $T_{amb} = 25\text{ }^\circ\text{C}$; typical values.

Input impedance derived from
 input reflection coefficient s_{ie}
 coordinates in ohm $\times 50$

7Z62899

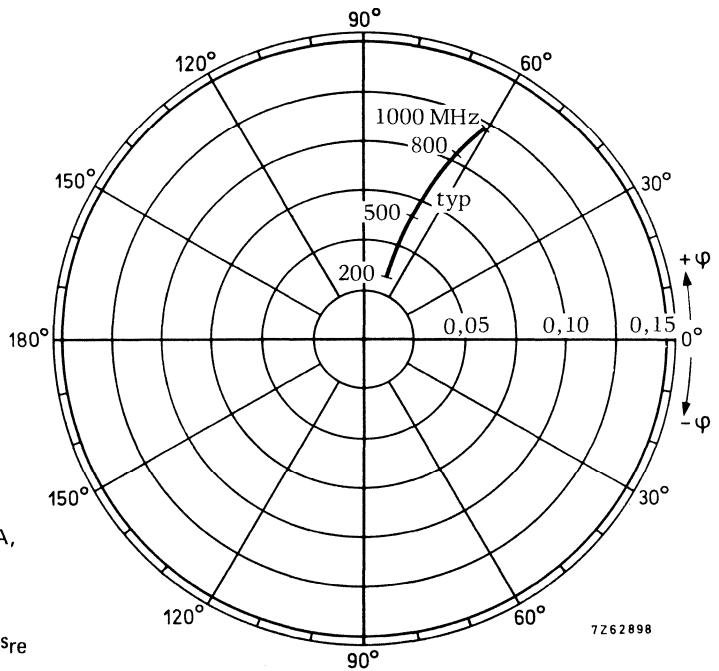

Fig. 13 $V_{CE} = 10\text{ V}$; $I_C = 14\text{ mA}$;
 $T_{amb} = 25\text{ }^\circ\text{C}$; typical values.

Reverse transmission coefficient s_{re}

7Z62898

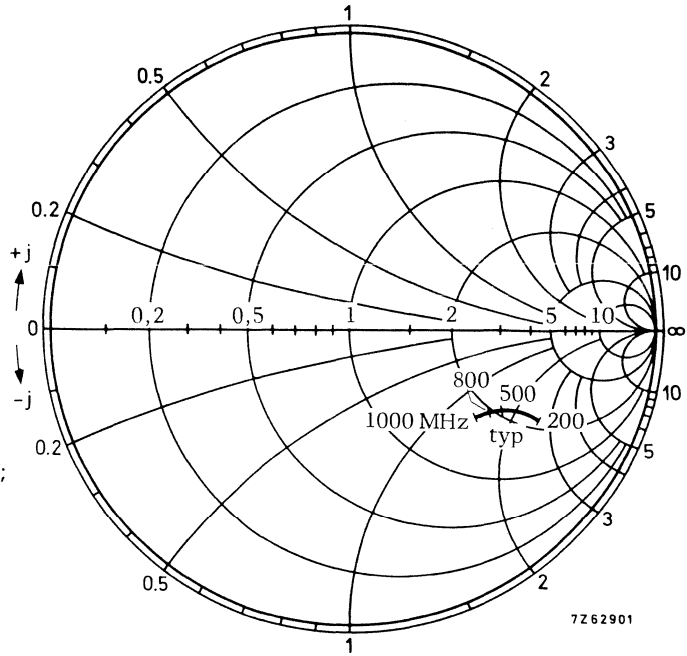

Fig. 14 $V_{CE} = 10\text{ V}$; $I_C = 14\text{ mA}$;
 $T_{amb} = 25\text{ }^\circ\text{C}$; typical values.

Output impedance derived from
 output reflection coefficient s_{oe}
 coordinates in ohm $\times 50$

7Z 62901

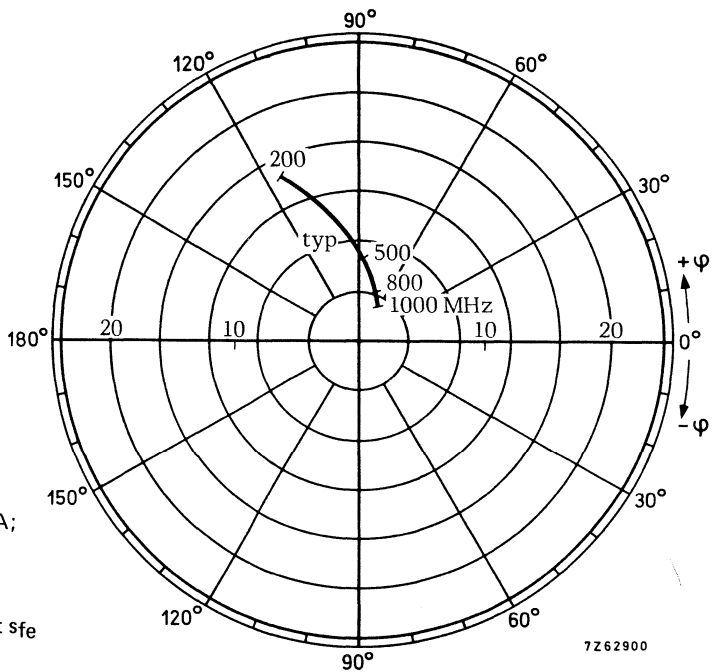

Fig. 15 $V_{CE} = 10\text{ V}$; $I_C = 14\text{ mA}$;
 $T_{amb} = 25\text{ }^\circ\text{C}$; typical values.

Forward transmission coefficient s_{fe}

7Z 62900

N-P-N 1 GHz WIDEBAND TRANSISTOR

N-P-N transistor in a plastic SOT-23 envelope. It is primarily intended for use in v.h.f./u.h.f. broadband amplifiers. The transistor features:

- low noise;
- low intermodulation distortion;
- high power gain.

P-N-P complement is BFT92

QUICK REFERENCE DATA

Collector-base voltage (open emitter)	V_{CBO}	max.	20 V
Collector-emitter voltage (open-base)	V_{CE0}	max.	15 V
Collector current (d.c.)	I_C	max.	25 mA
Total power dissipation up to $T_{amb} = 60\text{ }^\circ\text{C}$	P_{tot}	max.	200 mW
Junction temperature	T_j	max.	150 $^\circ\text{C}$
Transition frequency at $f = 500\text{ MHz}$ $I_C = 14\text{ mA}; V_{CE} = 10\text{ V}$	f_T	typ.	5,0 GHz
Feedback capacitance at $f = 1\text{ MHz}$ $I_C = 0; V_{CE} = 10\text{ V}$	C_{re}	typ.	0,35 pF
Noise figure at $R_S = 60\ \Omega$ $I_C = 4\text{ mA}; V_{CE} = 10\text{ V}; f = 800\text{ MHz}$	F	typ.	1,8 dB
Output voltage at $d_{im} = -60\text{ dB}$ $I_C = 14\text{ mA}; V_{CE} = 10\text{ V}; R_L = 75\ \Omega$ $f_{(p+q-r)} = 793,25\text{ MHz}$	V_o	typ.	150 mV

MECHANICAL DATA

Fig. 1 SOT-23.

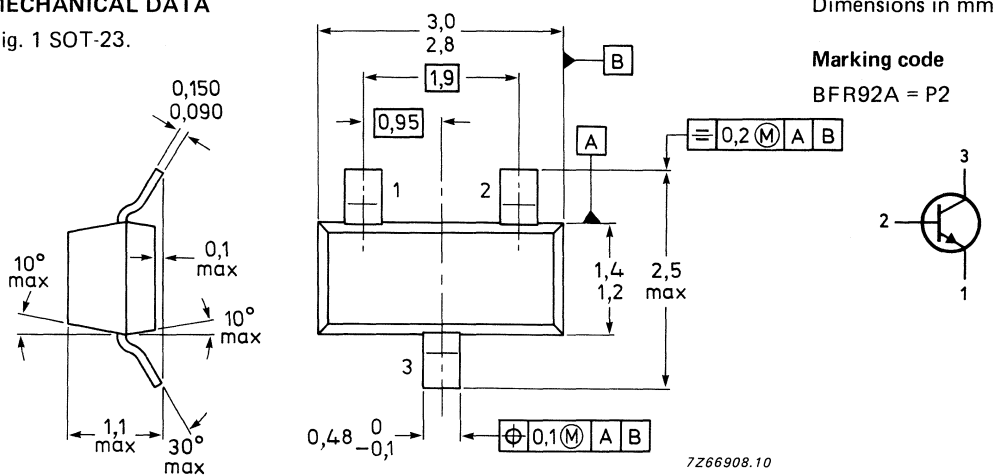

TOP VIEW

If required, the R-version (reverse pinning) is available on request.

RATINGS

Limiting values in accordance with the Absolute Maximum System (IEC 134)

Collector-base voltage (open emitter)	V_{CBO}	max.	20 V
Collector-emitter voltage (open base)	V_{CEO}	max.	15 V
Emitter-base voltage (open collector)	V_{EBO}	max.	2,0 V
Collector current (d.c.)	I_C	max.	25 mA
Total power dissipation up to $T_{amb} = 60\text{ }^\circ\text{C}^{**}$	P_{tot}	max.	200 mW
Storage temperature	T_{stg}		-65 to +150 $^\circ\text{C}$
Junction temperature	T_j	max.	150 $^\circ\text{C}$

THERMAL RESISTANCE*

From junction to ambient**	$R_{th\ j-a}$	=	430 K/W
----------------------------	---------------	---	---------

CHARACTERISTICS

$T_j = 25\text{ }^\circ\text{C}$ unless otherwise specified

Collector cut-off current

$$I_E = 0; V_{CB} = 10\text{ V}$$

I_{CBO}	max.	60 nA
-----------	------	-------

D.C. current gain

$$I_C = 14\text{ mA}; V_{CE} = 10\text{ V}$$

h_{FE}	min.	40
	typ.	90

Transition frequency at $f = 500\text{ MHz}$

$$I_C = 14\text{ mA}; V_{CE} = 10\text{ V}$$

f_T	typ.	5,0 GHz
-------	------	---------

Collector capacitance at $f = 1\text{ MHz}$

$$I_E = I_e = 0; V_{CB} = 10\text{ V}$$

C_c	typ.	0,6 pF
-------	------	--------

Emitter capacitance at $f = 1\text{ MHz}$

$$I_C = I_c = 0; V_{EB} = 0,5\text{ V}$$

C_e	typ.	1,2 pF
-------	------	--------

Feedback capacitance at $f = 1\text{ MHz}$

$$I_C = 0; V_{CE} = 10\text{ V}; T_{amb} = 25\text{ }^\circ\text{C}$$

C_{re}	typ.	0,35 pF
----------	------	---------

Noise figure at $T_{amb} = 25\text{ }^\circ\text{C}$

$$I_C = 4\text{ mA}; V_{CE} = 10\text{ V}; R_S = 60\text{ }\Omega; f = 800\text{ MHz}$$

F	typ.	1,8 dB
-----	------	--------

Maximum unilateral power gain (s_{re} assumed to be zero)

$$G_{UM} = 10 \log \frac{|s_{fe}|^2}{[1 - |s_{ie}|^2][1 - |s_{oe}|^2]}$$

$$I_C = 14\text{ mA}; V_{CE} = 10\text{ V}; f = 800\text{ MHz}; T_{amb} = 25\text{ }^\circ\text{C}$$

G_{UM}	typ.	15,5 dB
----------	------	---------

* See *Thermal characteristics*.

** Mounted on a ceramic substrate of 8 mm x 10 mm x 0,7 mm.

Output voltage at $d_{im} = -60$ dB (see Figs 2 and 17)*

(DIN 45004B, par. 6.3: 3-tone)

$I_C = 14$ mA; $V_{CE} = 10$ V; $R_L = 75 \Omega$; $V_{SWR} < 2$; $T_{amb} = 25$ °C

$V_p = V_o$ at $d_{im} = -60$ dB; $f_p = 795,25$ MHz

$V_q = V_o - 6$ dB ; $f_q = 803,25$ MHz

$V_r = V_o - 6$ dB ; $f_r = 805,25$ MHz

Measured at $f_{(p+q-r)} = 793,25$ MHz

V_o typ. 150 mV

Second harmonic distortion (see Figs 2 and 18)*

$I_C = 14$ mA; $V_{CE} = 10$ V; $R_L = 75 \Omega$; $V_{SWR} < 2$; $T_{amb} = 25$ °C

$V_p = 60$ mV at $f_p = 250$ MHz

$V_q = 60$ mV at $f_q = 560$ MHz

measured at $f_{(p+q)} = 810$ MHz

d_2 typ. -50 dB

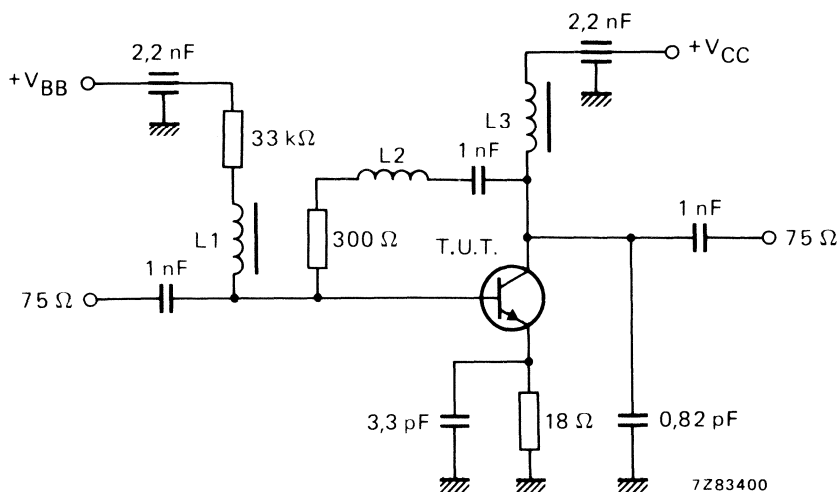

Fig. 2 Intermodulation distortion and second harmonic distortion MATV test circuit.

$L1 = L3 = 5 \mu\text{H}$ micro choke

$L2 = 3$ turns Cu wire (0,4 mm); internal diameter 3 mm; winding pitch 1 mm

* Measured on same crystal in a SOT-37 envelope (BFR90A).

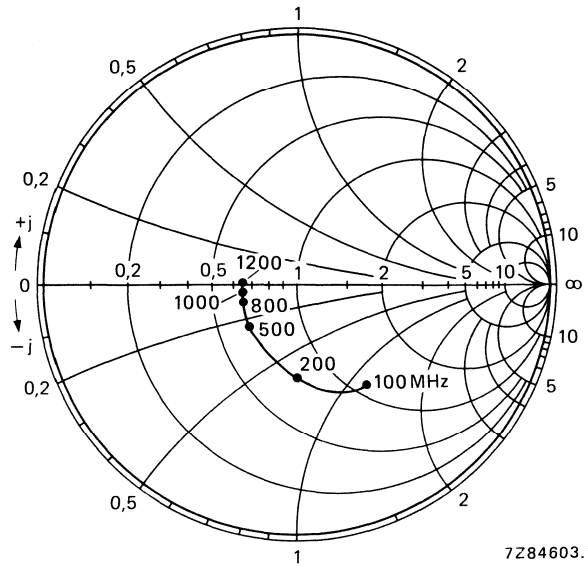

Fig. 3 Input impedance derived from input reflection coefficient s_{ie} co-ordinates in ohm \times 50. $V_{CE} = 10$ V; $I_C = 14$ mA; $T_{amb} = 25$ °C; typical values.

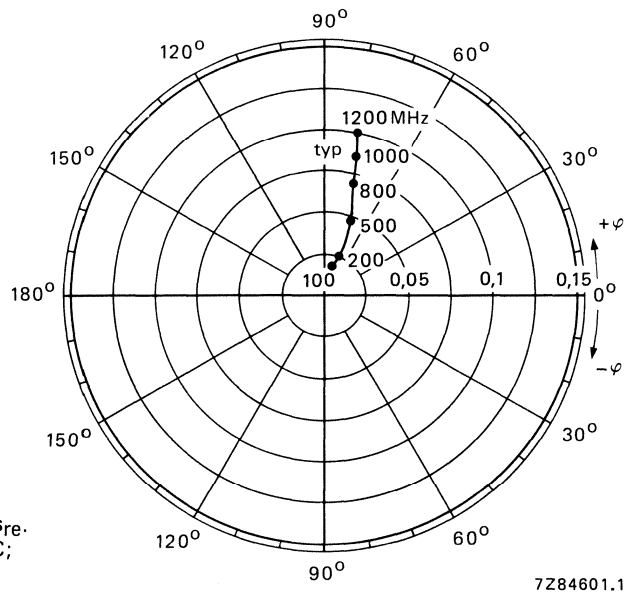
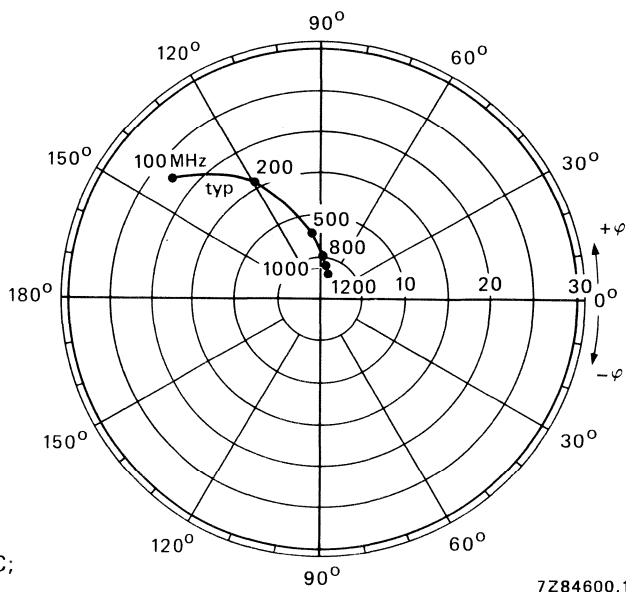
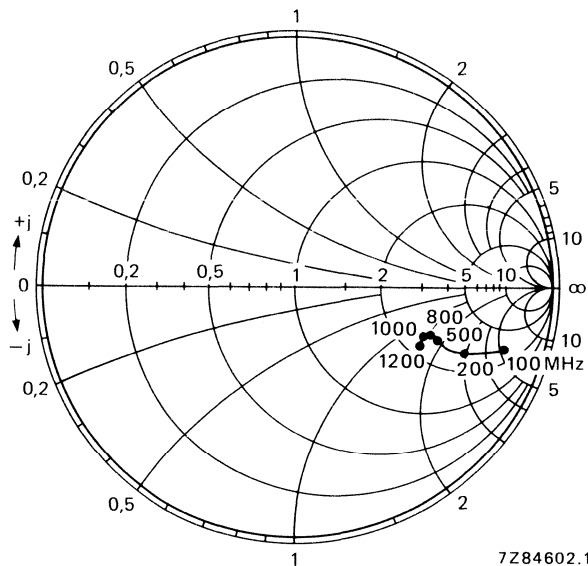

Fig. 4 Reverse transmission coefficient s_{re} . $V_{CE} = 10$ V; $I_C = 14$ mA; $T_{amb} = 25$ °C; typical values.



s-parameters (common emitter) at $V_{CE} = 5\text{ V}$; $T_{amb} = 25\text{ }^{\circ}\text{C}$; typical values.

I_C mA	f MHz	S_{ie}	S_{re}	S_{fe}	S_{oe}
2	40	0,88/ $-8,9^{\circ}$	0,009/83,6 $^{\circ}$	6,7/174,2 $^{\circ}$	1,00/ $-2,7^{\circ}$
	100	0,86/ $-21,9^{\circ}$	0,022/78,3 $^{\circ}$	6,5/164,2 $^{\circ}$	0,98/ $-6,6^{\circ}$
	200	0,80/ $-42,2^{\circ}$	0,041/69,0 $^{\circ}$	6,0/149,2 $^{\circ}$	0,94/ $-12,2^{\circ}$
	500	0,61/ $-87,2^{\circ}$	0,073/54,9 $^{\circ}$	4,2/119,1 $^{\circ}$	0,81/ $-20,2^{\circ}$
	800	0,48/ $-117,4^{\circ}$	0,086/52,7 $^{\circ}$	3,1/100,5 $^{\circ}$	0,74/ $-22,9^{\circ}$
	1000	0,44/ $-133,8^{\circ}$	0,092/54,2 $^{\circ}$	2,6/ 91,4 $^{\circ}$	0,71/ $-24,2^{\circ}$
	1200	0,41/ $-147,6^{\circ}$	0,099/57,5 $^{\circ}$	2,2/ 84,3 $^{\circ}$	0,70/ $-25,7^{\circ}$
5	40	0,75/ $-14,4^{\circ}$	0,008/81,8 $^{\circ}$	14,4/170,2 $^{\circ}$	0,99/ $-4,9^{\circ}$
	100	0,70/ $-34,0^{\circ}$	0,020/74,2 $^{\circ}$	13,3/155,3 $^{\circ}$	0,94/ $-11,2^{\circ}$
	200	0,60/ $-61,7^{\circ}$	0,034/65,0 $^{\circ}$	10,9/135,8 $^{\circ}$	0,84/ $-17,9^{\circ}$
	500	0,40/ $-111,1^{\circ}$	0,057/61,1 $^{\circ}$	6,2/106,9 $^{\circ}$	0,67/ $-21,9^{\circ}$
	800	0,32/ $-139,7^{\circ}$	0,074/65,5 $^{\circ}$	4,2/ 92,4 $^{\circ}$	0,62/ $-22,2^{\circ}$
	1000	0,30/ $-153,2^{\circ}$	0,086/68,2 $^{\circ}$	3,4/ 85,3 $^{\circ}$	0,61/ $-22,8^{\circ}$
	1200	0,29/ $-166,2^{\circ}$	0,100/70,9 $^{\circ}$	2,9/ 79,6 $^{\circ}$	0,60/ $-24,0^{\circ}$
10	40	0,61/ $-21,1^{\circ}$	0,008/79,7 $^{\circ}$	22,9/165,2 $^{\circ}$	0,97/ $-7,3^{\circ}$
	100	0,54/ $-48,5^{\circ}$	0,017/71,4 $^{\circ}$	19,8/145,8 $^{\circ}$	0,88/ $-15,5^{\circ}$
	200	0,42/ $-82,1^{\circ}$	0,028/65,2 $^{\circ}$	14,4/124,7 $^{\circ}$	0,74/ $-20,8^{\circ}$
	500	0,30/ $-132,3^{\circ}$	0,050/69,0 $^{\circ}$	7,1/ 99,6 $^{\circ}$	0,59/ $-20,5^{\circ}$
	800	0,26/ $-158,0^{\circ}$	0,072/73,7 $^{\circ}$	4,7/ 87,8 $^{\circ}$	0,56/ $-20,3^{\circ}$
	1000	0,25/ $-168,3^{\circ}$	0,088/75,2 $^{\circ}$	3,8/ 82,2 $^{\circ}$	0,56/ $-20,9^{\circ}$
	1200	0,25/ $-179,3^{\circ}$	0,104/76,6 $^{\circ}$	3,2/ 77,5 $^{\circ}$	0,55/ $-22,1^{\circ}$
14	40	0,53/ $-26,0^{\circ}$	0,007/78,6 $^{\circ}$	27,7/162,4 $^{\circ}$	0,96/ $-8,7^{\circ}$
	100	0,45/ $-58,1^{\circ}$	0,016/70,5 $^{\circ}$	22,6/140,7 $^{\circ}$	0,85/ $-17,2^{\circ}$
	200	0,36/ $-94,4^{\circ}$	0,025/66,6 $^{\circ}$	15,6/119,7 $^{\circ}$	0,70/ $-21,0^{\circ}$
	500	0,27/ $-142,8^{\circ}$	0,049/72,5 $^{\circ}$	7,3/ 96,9 $^{\circ}$	0,57/ $-19,1^{\circ}$
	800	0,25/ $-166,0^{\circ}$	0,072/76,5 $^{\circ}$	4,7/ 86,1 $^{\circ}$	0,55/ $-19,1^{\circ}$
	1000	0,24/ $-174,8^{\circ}$	0,088/77,4 $^{\circ}$	3,8/ 80,5 $^{\circ}$	0,55/ $-19,9^{\circ}$
	1200	0,24/ 174,8 $^{\circ}$	0,105/78,4 $^{\circ}$	3,2/ 76,2 $^{\circ}$	0,54/ $-21,3^{\circ}$
20	40	0,45/ $-33,1^{\circ}$	0,007/77,0 $^{\circ}$	32,3/158,8 $^{\circ}$	0,94/ $-10,1^{\circ}$
	100	0,38/ $-71,8^{\circ}$	0,015/69,5 $^{\circ}$	24,7/135,0 $^{\circ}$	0,80/ $-18,4^{\circ}$
	200	0,31/ $-110,6^{\circ}$	0,023/68,3 $^{\circ}$	16,0/114,6 $^{\circ}$	0,66/ $-20,1^{\circ}$
	500	0,26/ $-154,5^{\circ}$	0,047/75,5 $^{\circ}$	7,2/ 94,3 $^{\circ}$	0,56/ $-17,3^{\circ}$
	800	0,25/ $-174,2^{\circ}$	0,071/78,7 $^{\circ}$	4,7/ 84,3 $^{\circ}$	0,55/ $-17,8^{\circ}$
	1000	0,25/ 178,5 $^{\circ}$	0,088/79,3 $^{\circ}$	3,7/ 79,1 $^{\circ}$	0,54/ $-18,9^{\circ}$
	1200	0,26/ 169,9 $^{\circ}$	0,104/80,0 $^{\circ}$	3,2/ 74,9 $^{\circ}$	0,54/ $-20,5^{\circ}$

s-parameters (common emitter) at $V_{CE} = 10\text{ V}$; $T_{amb} = 25\text{ }^{\circ}\text{C}$; typical values.

I_C mA	f MHz	S_{ie}	S_{re}	S_{fe}	S_{oe}
2	40	0,89/ -8,7 ^o	0,008/83,6 ^o	6,8/174,4 ^o	1,00/ -2,5 ^o
	100	0,86/ -21,2 ^o	0,021/78,5 ^o	6,5/164,6 ^o	0,98/ -6,1 ^o
	200	0,80/ -40,9 ^o	0,038/69,5 ^o	6,0/149,6 ^o	0,94/ -11,3 ^o
	500	0,61/ -85,3 ^o	0,069/55,8 ^o	4,3/119,8 ^o	0,82/ -18,7 ^o
	800	0,48/ -115,4 ^o	0,081/53,8 ^o	3,1/101,2 ^o	0,75/ -21,3 ^o
	1000	0,44/ -131,4 ^o	0,086/55,5 ^o	2,6/ 92,1 ^o	0,73/ -22,5 ^o
	1200	0,40/ -145,6 ^o	0,093/58,9 ^o	2,2/ 85,0 ^o	0,72/ -23,9 ^o
5	40	0,77/ -13,6 ^o	0,008/81,8 ^o	14,2/170,5 ^o	0,99/ -4,5 ^o
	100	0,73/ -32,3 ^o	0,019/74,7 ^o	13,2/155,8 ^o	0,95/ -10,3 ^o
	200	0,62/ -58,8 ^o	0,032/65,6 ^o	11,0/136,8 ^o	0,85/ -16,6 ^o
	500	0,41/ -107,2 ^o	0,054/61,4 ^o	6,3/107,7 ^o	0,69/ -20,4 ^o
	800	0,32/ -135,9 ^o	0,071/65,9 ^o	4,2/ 92,9 ^o	0,64/ -20,8 ^o
	1000	0,30/ -150,0 ^o	0,082/68,6 ^o	3,5/ 86,1 ^o	0,63/ -21,3 ^o
	1200	0,28/ -162,9 ^o	0,095/71,5 ^o	2,9/ 80,5 ^o	0,62/ -22,4 ^o
10	40	0,66/ -19,4 ^o	0,007/80,1 ^o	22,5/165,9 ^o	0,97/ -6,6 ^o
	100	0,58/ -44,7 ^o	0,017/71,8 ^o	19,5/147,0 ^o	0,90/ -14,1 ^o
	200	0,45/ -76,2 ^o	0,027/65,4 ^o	14,5/126,0 ^o	0,76/ -19,3 ^o
	500	0,29/ -125,1 ^o	0,049/68,7 ^o	7,2/100,6 ^o	0,62/ -19,2 ^o
	800	0,24/ -151,8 ^o	0,070/73,5 ^o	4,7/ 88,8 ^o	0,59/ -19,0 ^o
	1000	0,24/ -162,9 ^o	0,084/75,2 ^o	3,8/ 82,6 ^o	0,58/ -19,7 ^o
	1200	0,23/ -174,8 ^o	0,099/76,8 ^o	3,2/ 78,3 ^o	0,58/ -20,9 ^o
14	40	0,60/ -23,2 ^o	0,007/78,6 ^o	27,2/163,0 ^o	0,96/ -7,9 ^o
	100	0,51/ -52,5 ^o	0,016/70,6 ^o	22,6/141,8 ^o	0,86/ -15,8 ^o
	200	0,38/ -86,2 ^o	0,025/66,4 ^o	15,7/120,7 ^o	0,72/ -19,6 ^o
	500	0,26/ -134,3 ^o	0,047/72,0 ^o	7,5/ 97,8 ^o	0,60/ -18,0 ^o
	800	0,22/ -159,3 ^o	0,069/76,2 ^o	4,8/ 86,8 ^o	0,57/ -18,0 ^o
	1000	0,22/ -169,0 ^o	0,085/77,3 ^o	3,9/ 81,3 ^o	0,57/ -18,7 ^o
	1200	0,22/ 179,8 ^o	0,100/78,5 ^o	3,3/ 76,8 ^o	0,57/ -20,1 ^o
20	40	0,54/ -28,2 ^o	0,007/77,4 ^o	31,7/159,9 ^o	0,95/ -9,1 ^o
	100	0,45/ -61,7 ^o	0,015/69,5 ^o	24,7/136,8 ^o	0,82/ -16,8 ^o
	200	0,33/ -97,5 ^o	0,023/67,5 ^o	16,3/116,2 ^o	0,68/ -18,8 ^o
	500	0,24/ -143,7 ^o	0,046/74,4 ^o	7,4/ 95,3 ^o	0,59/ -16,4 ^o
	800	0,22/ -166,4 ^o	0,069/78,0 ^o	4,8/ 85,2 ^o	0,57/ -16,9 ^o
	1000	0,22/ -174,7 ^o	0,084/78,7 ^o	3,8/ 80,1 ^o	0,57/ -17,8 ^o
	1200	0,22/ 176,3 ^o	0,100/79,7 ^o	3,3/ 76,0 ^o	0,57/ -19,4 ^o

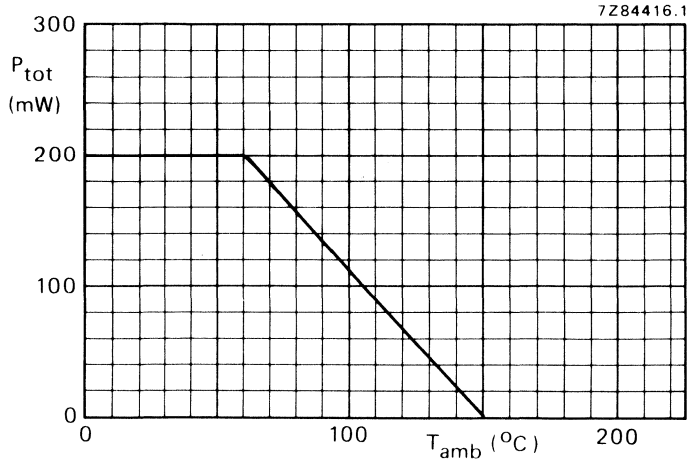

Fig. 7 Power derating curve.

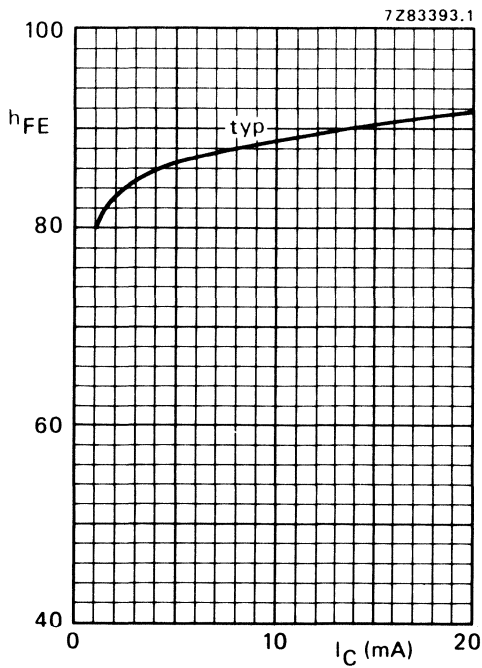

Fig. 8 $V_{CE} = 10$ V; $T_j = 25$ °C; typical values.

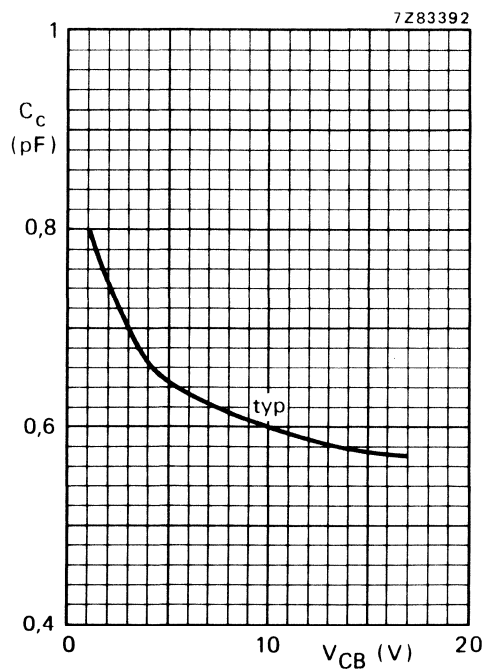

Fig. 9 $I_E = I_e = 0$; $f = 1$ MHz; $T_j = 25$ °C; typical values.

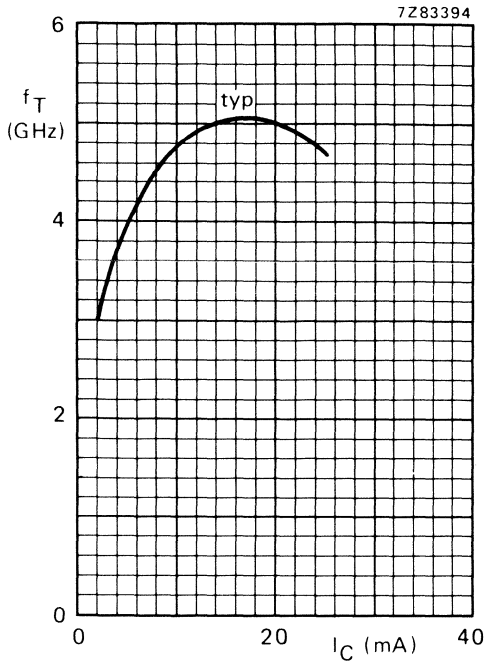

Fig. 10 $V_{CE} = 10 \text{ V}$; $f = 500 \text{ MHz}$; $T_j = 25 \text{ }^\circ\text{C}$; typical values.

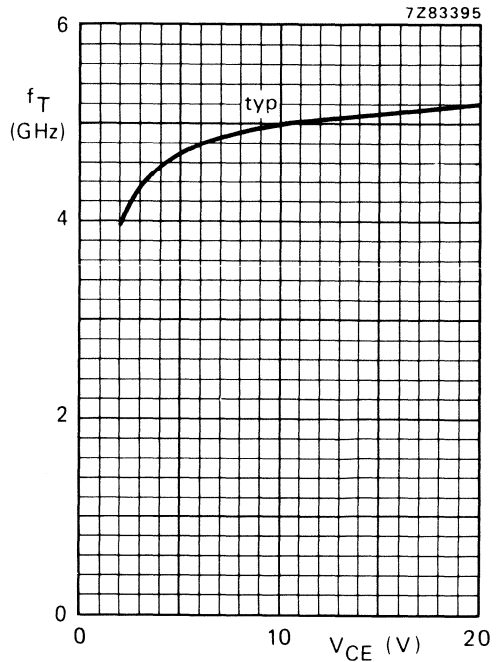

Fig. 11 $I_C = 14 \text{ mA}$; $f = 500 \text{ MHz}$; $T_j = 25 \text{ }^\circ\text{C}$; typical values.

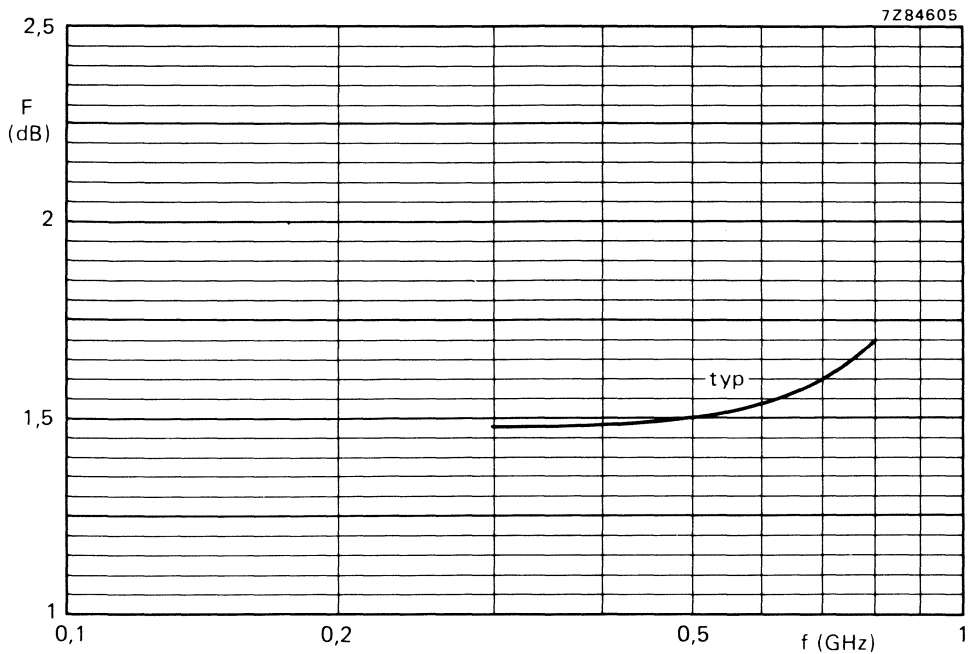

Fig. 12 $V_{CE} = 10 \text{ V}$; $I_C = 4 \text{ mA}$; $Z_S = \text{optimum}$; $T_{\text{amb}} = 25 \text{ }^\circ\text{C}$; typical values.

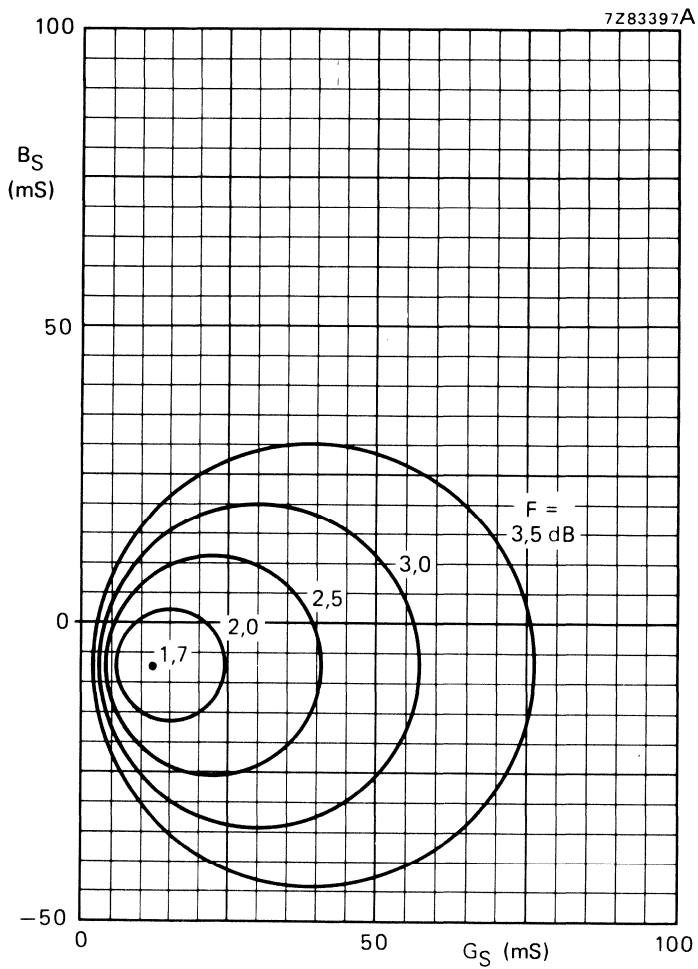

Fig. 13 Circles of constant noise figure.
 $V_{CE} = 10 \text{ V}$; $I_C = 4 \text{ mA}$; $f = 800 \text{ MHz}$; $T_{amb} = 25 \text{ }^\circ\text{C}$;
 typical values.

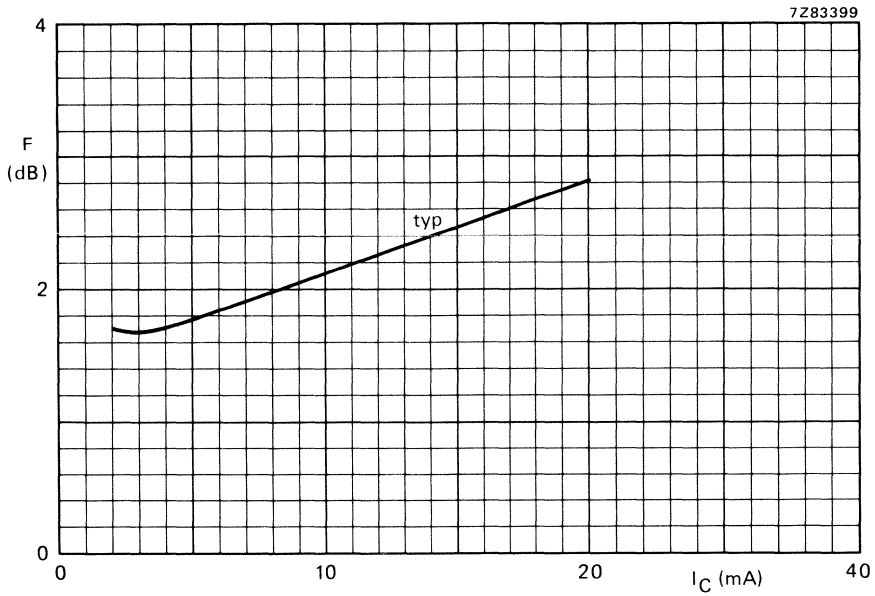

Fig. 14 $V_{CE} = 10$ V; $f = 800$ MHz; $Z_S = \text{optimum}$; $T_{amb} = 25$ °C; typical values.

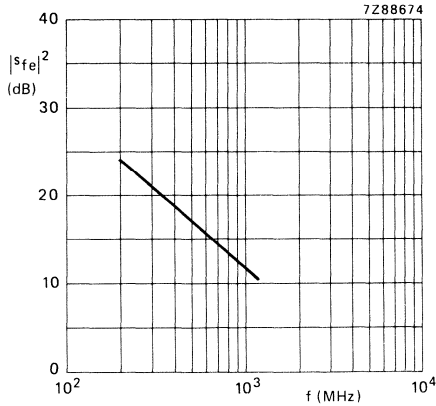

Fig. 15 $V_{CE} = 10$ V; $I_C = 14$ mA; $T_{amb} = 25$ °C; typical values.

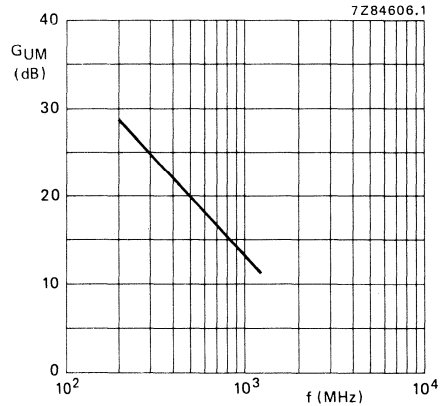

Fig. 16 $V_{CE} = 10$ V; $I_C = 14$ mA; $T_{amb} = 25$ °C; typical values.

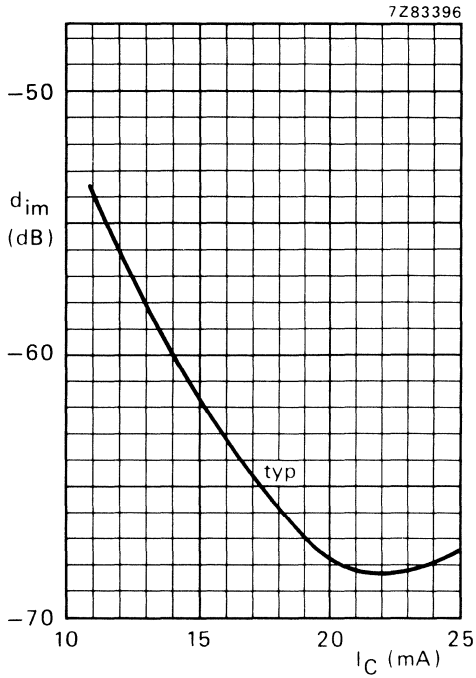

Fig. 17 $V_{CE} = 10$ V; $V_o = 43,5$ dBmV = 150 mV;
 $f_{(p+q-r)} = 793,25$ MHz; $T_{amb} = 25$ °C;
 measured in MATV test circuit (see Fig. 2);
 typical values.

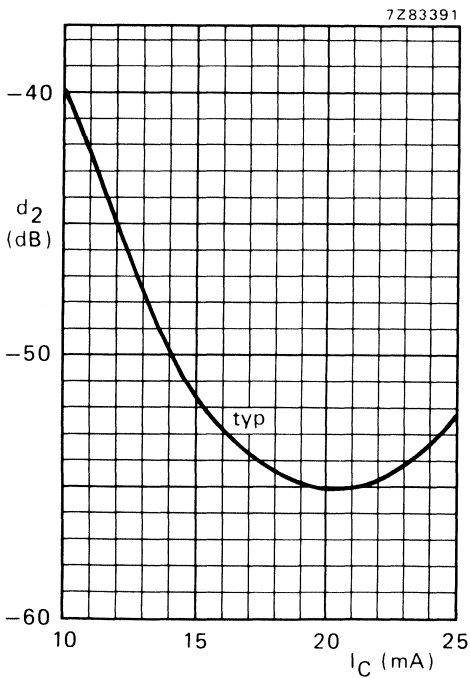

Fig. 18 $V_{CE} = 10$ V; $V_o = 60$ mV;
 $f_{(p+q)} = 810$ MHz; $T_{amb} = 25$ °C; measured in
 MATV test circuit (see Fig. 2); typical values.

N-P-N 1 GHz WIDEBAND TRANSISTOR

N-P-N transistor in a SOT-23 plastic envelope. It is primarily intended for use in u.h.f. and microwave amplifiers in thick and thin-film circuits, such as in aerial amplifiers, radar systems, oscilloscopes, spectrum analysers etc. The transistor features very low intermodulation distortion and high power gain; thanks to its very high transition frequency, it also has excellent wideband properties and low noise up to high frequencies.

P-N-P complement is the BFT93.

QUICK REFERENCE DATA

Collector-base voltage (open emitter)	V_{CBO}	max.	15 V
Collector-emitter voltage (open base)	V_{CEO}	max.	12 V
Collector current (d.c.)	I_C	max.	35 mA
Total power dissipation up to $T_{amb} = 60\text{ }^\circ\text{C}$	P_{tot}	max.	200 mW
Junction temperature	T_j	max.	150 $^\circ\text{C}$
Transition frequency at $f = 500\text{ MHz}$ $I_C = 30\text{ mA}$; $V_{CE} = 5\text{ V}$	f_T	typ.	5 GHz
Feedback capacitance at $f = 1\text{ MHz}$ $I_C = 2\text{ mA}$; $V_{CE} = 5\text{ V}$	C_{re}	typ.	0,8 pF
Noise figure at optimum source impedance $I_C = 2\text{ mA}$; $V_{CE} = 5\text{ V}$; $f = 500\text{ MHz}$;	F	typ.	1,9 dB
Max. unilateral power gain $I_C = 30\text{ mA}$; $V_{CE} = 5\text{ V}$; $f = 500\text{ MHz}$;	G_{UM}	typ.	16,5 dB
Intermodulation distortion at $T_{amb} = 25\text{ }^\circ\text{C}$ $I_C = 30\text{ mA}$; $V_{CE} = 5\text{ V}$; $R_L = 75\text{ }\Omega$; $V_o = 300\text{ mV}$ $f_{(p+q-r)} = 493,25\text{ MHz}$	d_{im}	typ.	-60 dB

MECHANICAL DATA

Fig. 1 SOT-23.

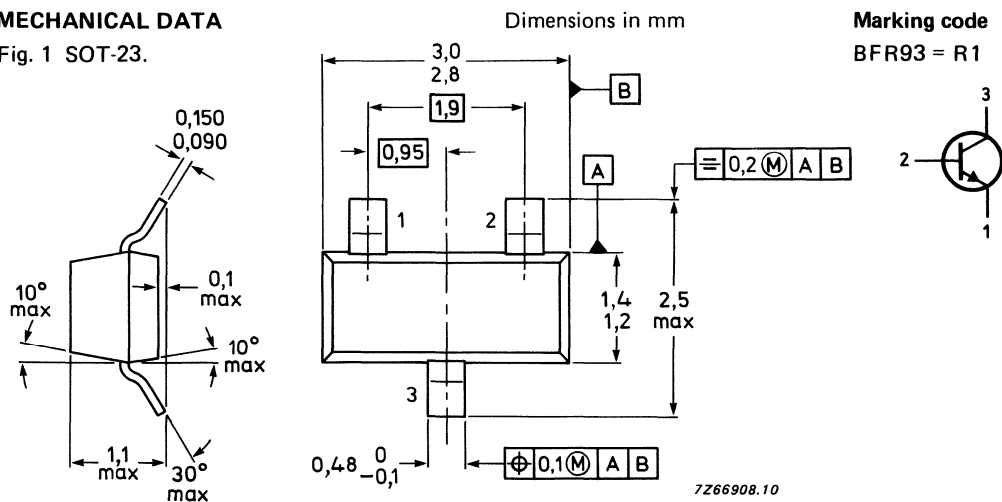

TOP VIEW

If required, the R-version (reverse pinning) is available on request.

RATINGS

Limiting values in accordance with the Absolute Maximum System (IEC 134)

Collector-base voltage (open emitter)	V_{CBO}	max.	15 V
Collector-emitter voltage (open base)	V_{CEO}	max.	12 V
Emitter-base voltage (open collector)	V_{EBO}	max.	2,0 V
Collector current (d.c.)	I_C	max.	35 mA
Total power dissipation up to $T_{amb} = 60\text{ }^{\circ}\text{C}^{**}$	P_{tot}	max.	200 mW
Storage temperature	T_{stg}		-65 to +150 $^{\circ}\text{C}$
Junction temperature	T_j	max.	150 $^{\circ}\text{C}$

THERMAL CHARACTERISTICS *

$$T_j = P \times (R_{th\ j-t} + R_{th\ t-s} + R_{th\ s-a}) + T_{amb}$$

Thermal resistance

From junction to tab	$R_{th\ j-t}$	=	60 K/W
From tab to soldering points	$R_{th\ t-s}$	=	280 K/W
From soldering points to ambient **	$R_{th\ s-a}$	=	90 K/W

CHARACTERISTICS $T_j = 25\text{ }^{\circ}\text{C}$ unless otherwise specified

Collector cut-off current

$I_E = 0; V_{CB} = 10\text{ V}$

I_{CBO}	max.	50 nA
-----------	------	-------

D.C. current gain \blacktriangle

$I_C = 30\text{ mA}; V_{CE} = 5\text{ V}$

h_{FE}	min.	25
	typ.	50

Transition frequency at $f = 500\text{ MHz}$ \blacktriangle

$I_C = 30\text{ mA}; V_{CE} = 5\text{ V}$

f_T	typ.	5 GHz
-------	------	-------

Collector capacitance at $f = 1\text{ MHz}$

$I_E = I_e = 0; V_{CB} = 10\text{ V}$

C_C	typ.	0,7 pF
-------	------	--------

Emitter capacitance at $f = 1\text{ MHz}$

$I_C = I_c = 0; V_{EB} = 0,5\text{ V}$

C_e	typ.	1,8 pF
-------	------	--------

Feedback capacitance at $f = 1\text{ MHz}$

$I_C = 2\text{ mA}; V_{CE} = 5\text{ V}; T_{amb} = 25\text{ }^{\circ}\text{C}$

C_{re}	typ.	0,8 pF
----------	------	--------

 \blacktriangle Measured under pulse conditions.* See *Thermal characteristics*.

** Mounted on a ceramic substrate of 8 mm x 10 mm x 0,7 mm.

Noise figure at optimum source impedance *

$I_C = 2 \text{ mA}; V_{CE} = 5 \text{ V}; f = 500 \text{ MHz}; T_{amb} = 25 \text{ }^\circ\text{C}$

F typ. 1,9 dB

Max. unilateral power gain (s_{re} assumed to be zero)

$$G_{UM} = 10 \log \frac{|s_{fe}|^2}{(1 - |s_{ic}|^2)(1 - |s_{oc}|^2)}$$

$I_C = 30 \text{ mA}; V_{CE} = 5 \text{ V}; f = 500 \text{ MHz}; T_{amb} = 25 \text{ }^\circ\text{C}$

GUM typ. 16,5 dB

Intermodulation distortion at $T_{amb} = 25 \text{ }^\circ\text{C}$ *

$I_C = 30 \text{ mA}; V_{CE} = 5 \text{ V}; R_L = 75 \text{ } \Omega; \text{V.S.W.R.} < 2$

$V_p = V_o = 300 \text{ mV}$ at $f_p = 495,25 \text{ MHz}$

$V_q = V_o - 6 \text{ dB}$ at $f_q = 503,25 \text{ MHz}$

$V_r = V_o - 6 \text{ dB}$ at $f_r = 505,25 \text{ MHz}$

Measured at $f(p + q - r) = 493,25 \text{ MHz}$

d_{im} typ. -60 dB

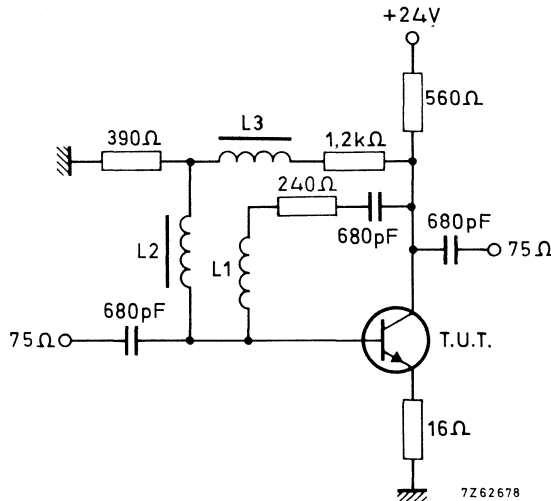

Fig. 2 Intermodulation test circuit.

L1 = 4 turns Cu wire (0,35); winding pitch 1 mm; int. dia. 4 mm
 L2 and L3 5 μH (code number: 3122 108 20150)

* Crystal mounted in a BFR91 envelope.

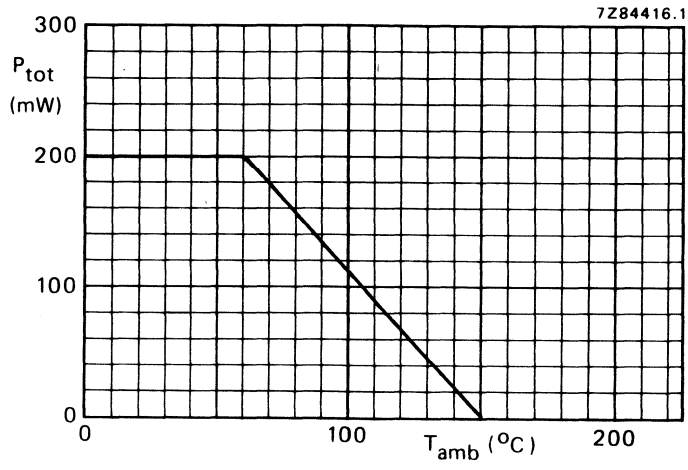

Fig. 3 Power derating curve.

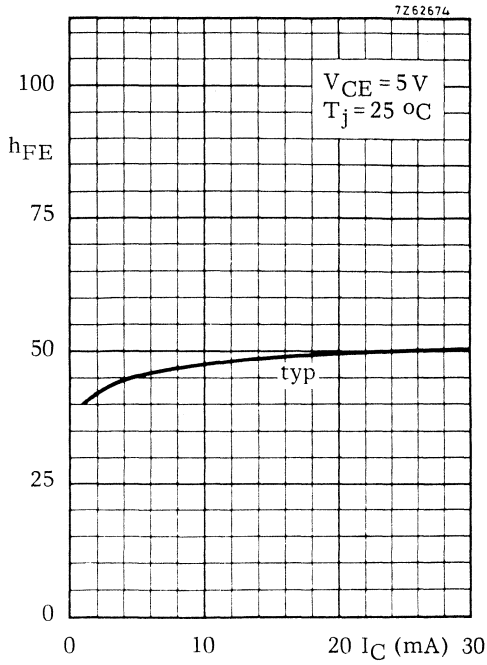

Fig. 4.

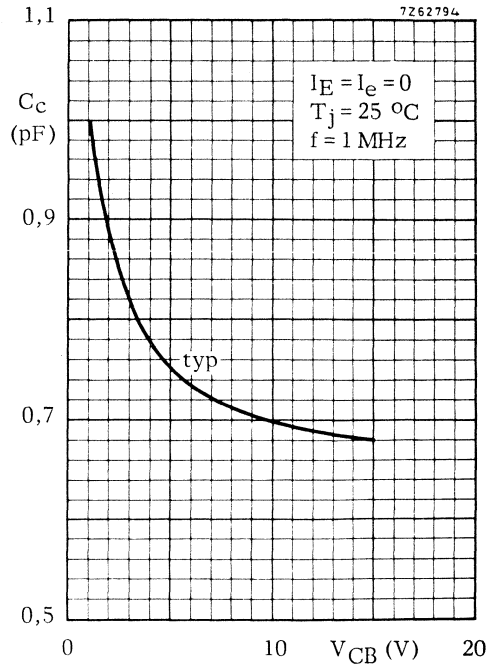

Fig. 5.

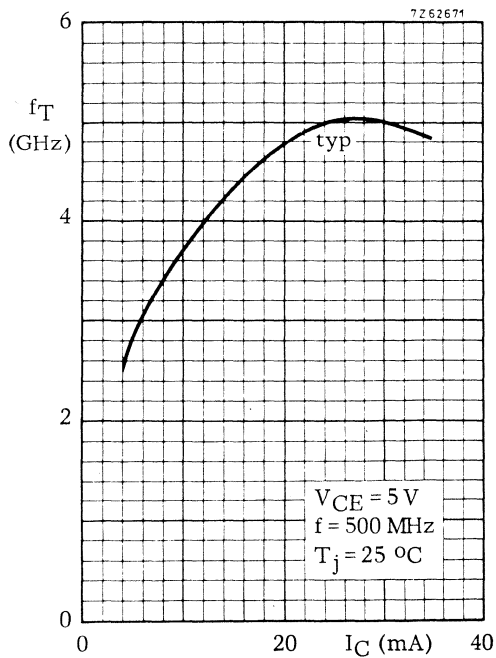

Fig. 6.

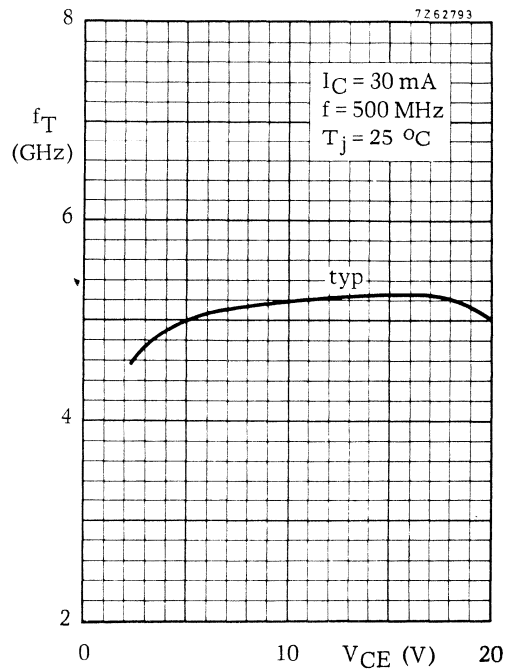

Fig. 7.

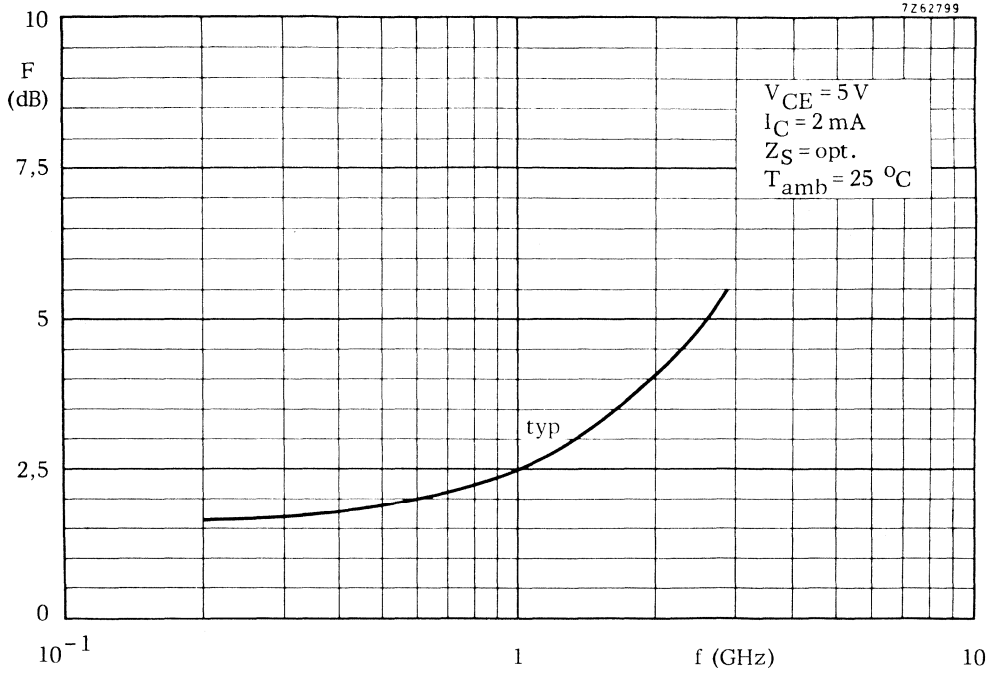

Fig. 8.

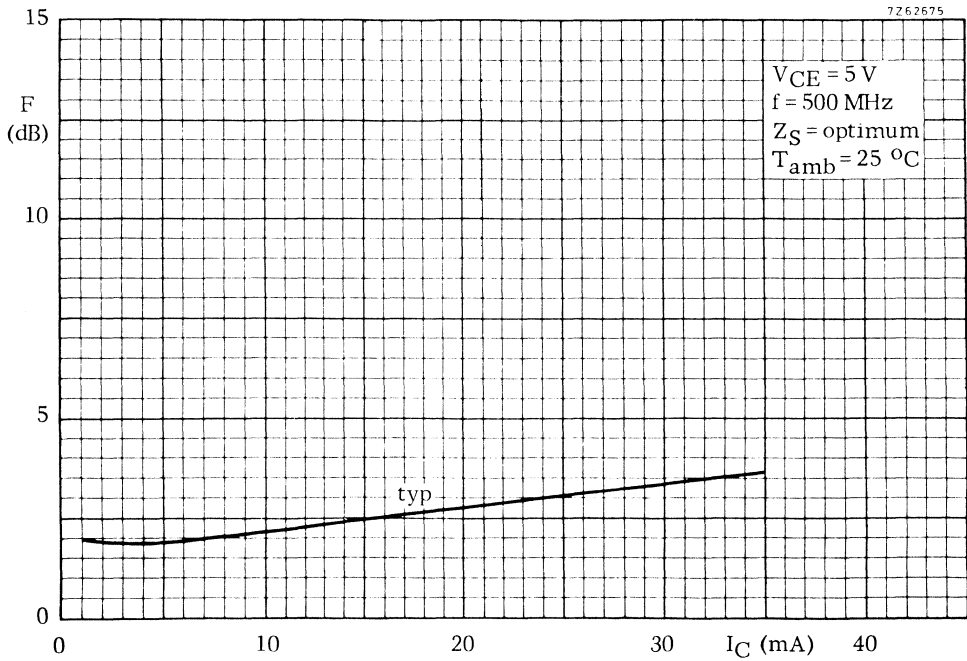

Fig. 9.

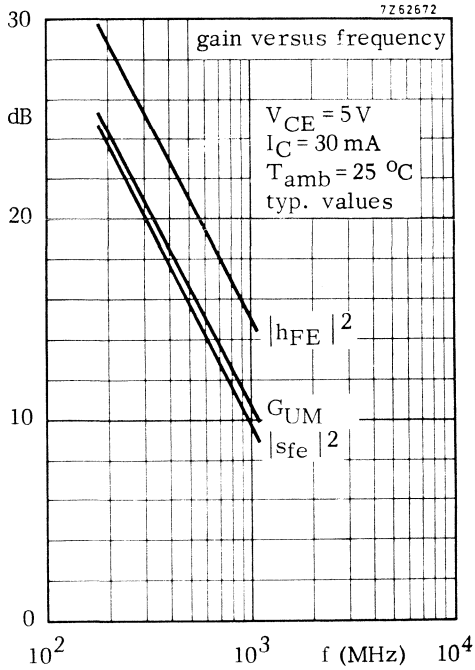

Fig. 10.

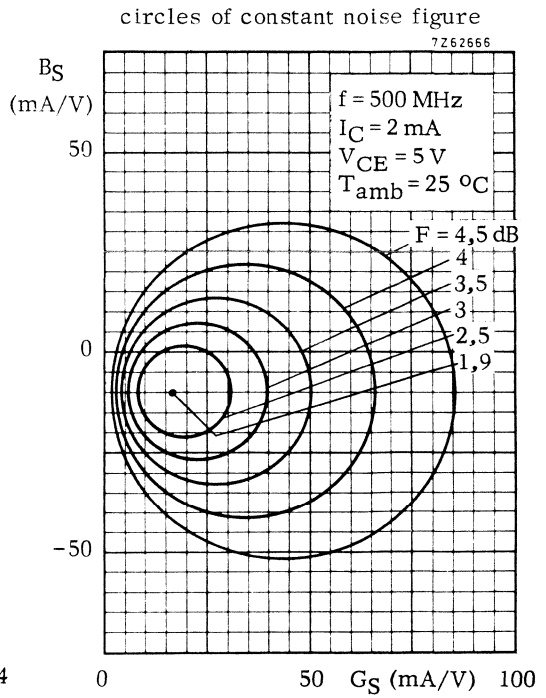
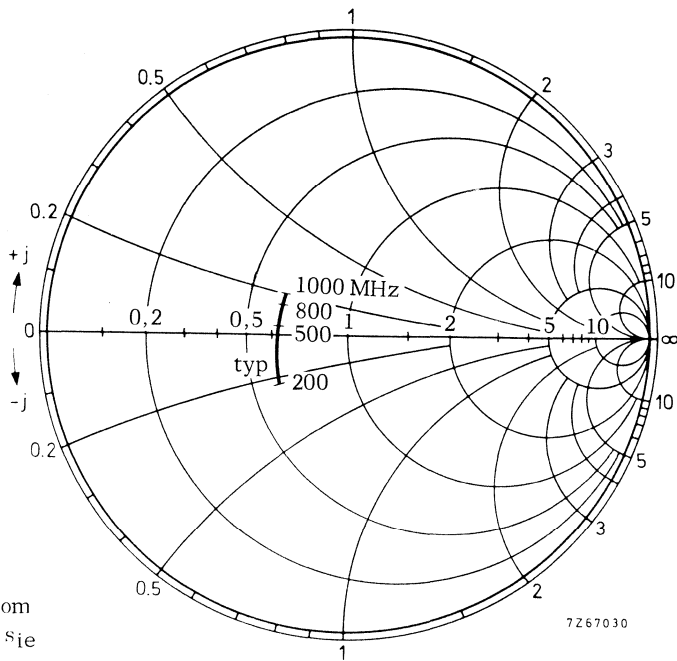

Fig. 11.

$V_{CE} = 5 \text{ V}$
 $I_C = 30 \text{ mA}$
 $T_{amb} = 25 \text{ }^\circ\text{C}$

Fig. 12.

Input impedance derived from
input reflection coefficient s_{ie}
coordinates in ohm $\times 50$



$V_{CE} = 5 \text{ V}$
 $I_C = 30 \text{ mA}$
 $T_{amb} = 25 \text{ }^\circ\text{C}$

Fig. 13.

Reverse transmission coefficient s_{re}

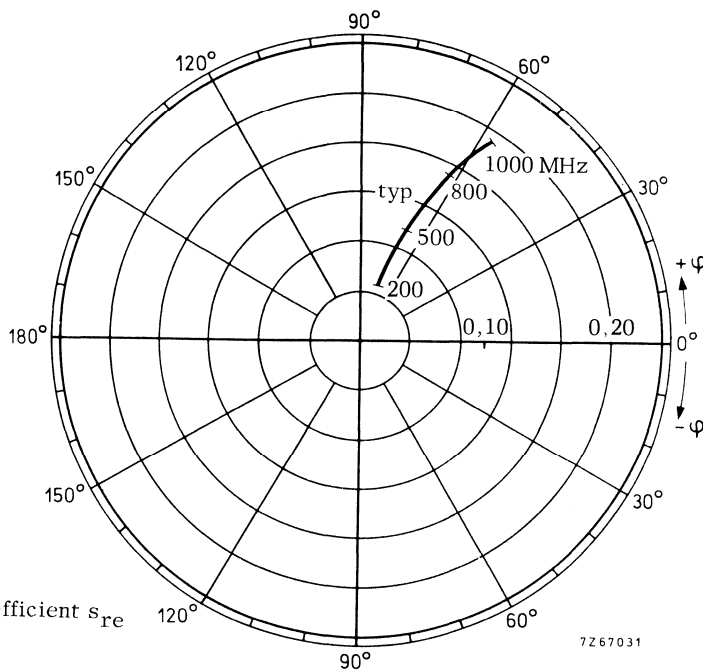

$V_{CE} = 5\text{ V}$
 $I_C = 30\text{ mA}$
 $T_{amb} = 25\text{ }^\circ\text{C}$

Fig. 14.

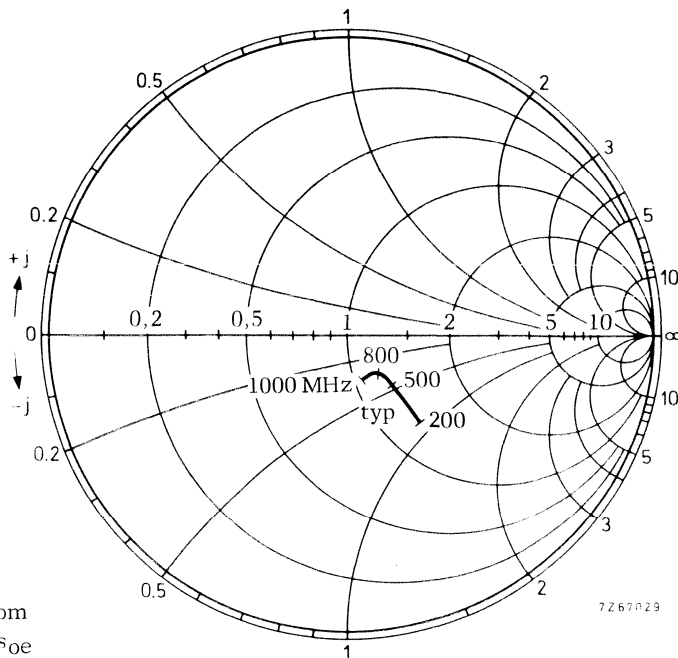

$V_{CE} = 5\text{ V}$
 $I_C = 30\text{ mA}$
 $T_{amb} = 25\text{ }^\circ\text{C}$

Fig. 15.

Forward transmission coefficient s_{fe}

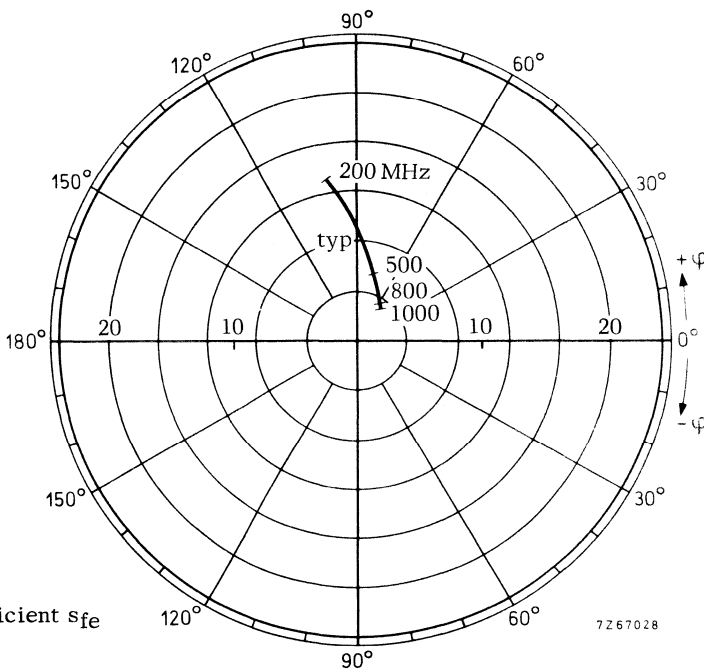

N-P-N 1 GHz WIDEBAND TRANSISTOR

N-P-N transistors in a SOT-23 plastic envelope. They are primarily intended for use in v.h.f./u.h.f. broadband amplifiers. The transistors feature:

- low noise;
- very low intermodulation distortion;
- high power gain;
- P-N-P complement to the BFR93

QUICK REFERENCE DATA

Collector-base voltage (open emitter)	V_{CBO}	max.	15 V
Collector-emitter voltage (open base)	V_{CEO}	max.	12 V
Collector current (d.c.)	I_C	max.	35 mA
Total power dissipation up to $T_{amb} = 45\text{ }^\circ\text{C}$	P_{tot}	max.	250 mW
Junction temperature	T_j	max.	150 $^\circ\text{C}$
Transition frequency at $f = 500\text{ MHz}$ $I_C = 30\text{ mA}; V_{CE} = 5\text{ V}$	f_T	typ.	5 GHz
Feedback capacitance at $f = 1\text{ MHz}$ $I_C = 0; V_{CE} = 5\text{ V}; T_{amb} = 25\text{ }^\circ\text{C}$	C_{re}	typ.	0,6 pF
Noise figure at optimum source impedance $I_C = 4\text{ mA}; V_{CE} = 8\text{ V}; f = 800\text{ MHz}$	F	typ.	1,6 dB
Output voltage at $d_{im} = -60\text{ dB}$ $I_C = 30\text{ mA}; V_{CE} = 8\text{ V}; R_L = 75\text{ }\Omega; T_{amb} = 25\text{ }^\circ\text{C}$ $f_{(p+q-r)} = 793,25\text{ MHz}$	V_o	typ.	425 mV

MECHANICAL DATA

Fig. 1 SOT-23.

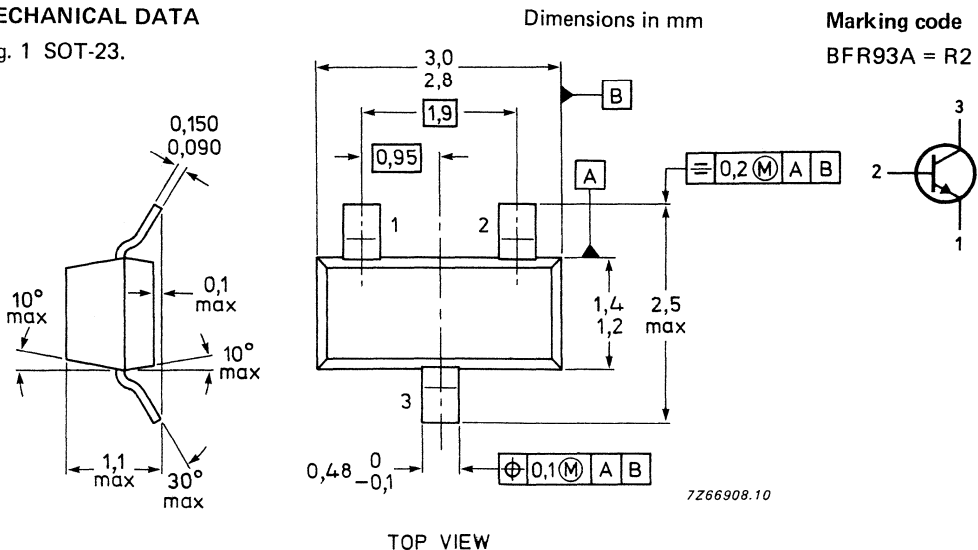

If required, the R-version (reverse pinning) is available on request
See also *Soldering recommendations*.

RATINGS

Limiting values in accordance with the Absolute Maximum System (IEC 134)

Collector-base voltage (open emitter)	V_{CBO}	max.	15 V
Collector-emitter voltage (open base)	V_{CEO}	max.	12 V
Emitter-base voltage (open collector)	V_{EBO}	max.	2,0 V
Collector current (d.c.)	I_C	max.	35 mA
Total power dissipation up to $T_{amb} = 45\text{ }^\circ\text{C}^{**}$	P_{tot}	max.	250 mW
Storage temperature	T_{stg}		-65 to + 150 $^\circ\text{C}$
Junction temperature	T_j	max.	150 $^\circ\text{C}$

THERMAL CHARACTERISTICS*

$$T_j = P \times (R_{th\ j-t} + R_{th\ t-s} + R_{th\ s-a}) + T_{amb}$$

Thermal resistance

From junction to tab	$R_{th\ j-t}$	=	60 K/W
From tab to soldering points	$R_{th\ t-s}$	=	280 K/W
From soldering points to ambient**	$R_{th\ s-a}$	=	90 K/W

CHARACTERISTICS

$T_j = 25\text{ }^\circ\text{C}$ unless otherwise specified

Collector cut-off current

$$I_E = 0; V_{CB} = 5\text{ V}$$

I_{CBO}	max.	50 nA
-----------	------	-------

D.C. current gain▲

$$I_C = 30\text{ mA}; V_{CE} = 5\text{ V}$$

h_{FE}	min.	40
	typ.	90

Transition frequency at $f = 500\text{ MHz}$ ▲

$$I_C = 30\text{ mA}; V_{CE} = 5\text{ V}$$

f_T	typ.	5 GHz
-------	------	-------

Collector capacitance at $f = 1\text{ MHz}$

$$I_E = I_e = 0; V_{CB} = 5\text{ V}$$

C_c	typ.	0,7 pF
-------	------	--------

Emitter capacitance at $f = 1\text{ MHz}$

$$I_C = I_c = 0; V_{EB} = 0,5\text{ V}$$

C_e	typ.	1,9 pF
-------	------	--------

Feedback capacitance at $f = 1\text{ MHz}$

$$I_C = 0; V_{CE} = 5\text{ V}; T_{amb} = 25\text{ }^\circ\text{C}$$

C_{re}	typ.	0,6 pF
----------	------	--------

Noise figure at optimum source impedance▲

$$I_C = 4\text{ mA}; V_{CE} = 8\text{ V}; f = 800\text{ MHz}$$

F	typ.	1,6 dB
-----	------	--------

$$I_C = 30\text{ mA}; V_{CE} = 8\text{ V}; f = 800\text{ MHz}$$

F	typ.	2,3 dB
-----	------	--------

Maximum unilateral power gain (s_{re} assumed to be zero)

See Figs 10 to 15

$$G_{UM} \text{ (in dB)} = 10 \log \frac{|s_{fe}|^2}{(1 - |s_{ie}|^2)(1 - |s_{oe}|^2)}$$

$$I_C = 30\text{ mA}; V_{CE} = 8\text{ V}; f = 800\text{ MHz}; T_{amb} = 25\text{ }^\circ\text{C}$$

G_{UM}	typ.	14 dB
----------	------	-------

▲ Measured under pulse conditions.

* See *Thermal characteristics*.

** Mounted on a ceramic substrate of 8 mm x 10 mm x 0,7 mm.

Output voltage at $d_{im} = -60$ dB (see Figs 2 and 16)*

(DIN 45004B, par. 6.3: 3-tone)

$I_C = 30$ mA; $V_{CE} = 8$ V; $R_L = 75 \Omega$; $T_{amb} = 25$ °C

$V_p = V_o$ at $d_{im} = -60$ dB; $f_p = 795,25$ MHz

$V_q = V_o -6$ dB ; $f_q = 803,25$ MHz

$V_r = V_o -6$ dB ; $f_r = 805,25$ MHz

Measured at $f_{(p+q-r)} = 793,25$ MHz

V_o typ. 425 mV

Second harmonic distortion (see Figs 2 and 17)*

$I_C = 30$ mA; $V_{CE} = 8$ V; $R_L = 75 \Omega$; $T_{amb} = 25$ °C

$V_p = 200$ mV at $f_p = 250$ MHz

$V_q = 200$ mV at $f_q = 560$ MHz

measured at $f_{(p+q)} = 810$ MHz

d_2 typ. -50 dB

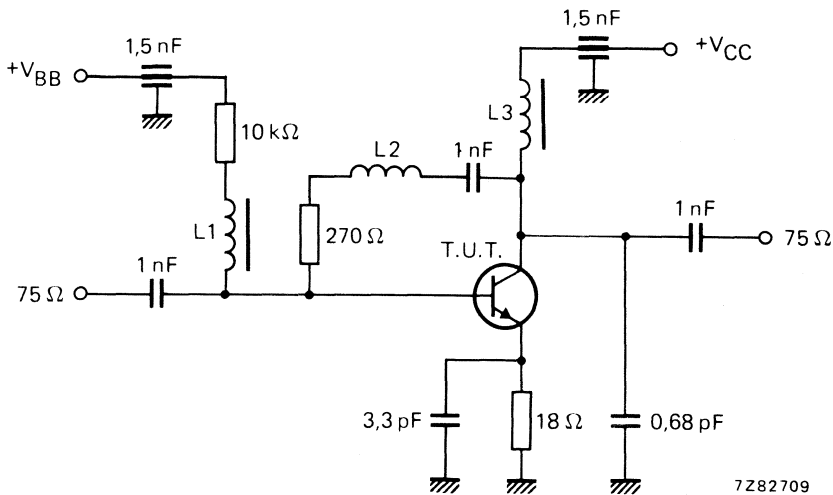

Fig. 2 Intermodulation distortion and second harmonic distortion MATV test circuit.

L1 = L3 = 5 μH micro choke

L2 = 3 turns Cu wire (0,4 mm); internal diameter 3 mm; winding pitch 1 mm.

* Measured on same crystal in a SOT-37 envelope (BFR91A).

s-parameters (common emitter)

V_{CE} V	I_C mA	f MHz	S_{ie}	S_{re}	S_{fe}	S_{oe}
5	2	40	0,89/ -12,4°	0,016/82,3°	7,0/171,8°	0,88/ -4,8°
		100	0,87/ -30,1°	0,038/74,2°	6,7/160,1°	0,96/-11,3°
		200	0,80/ -56,3°	0,067/61,8°	6,0/142,3°	0,88/-20,1°
		500	0,64/-109,5°	0,106/44,3°	3,8/110,6°	0,69/-31,9°
		800	0,57/-140,3°	0,116/41,8°	2,7/ 91,5°	0,60/-35,5°
		1000	0,54/-154,5°	0,119/43,9°	2,2/ 82,8°	0,58/-38,0°
5	5	1200	0,53/-166,6°	0,124/48,2°	1,9/ 75,1°	0,56/-40,2°
		40	0,77/ -19,9°	0,015/79,4°	15,1/166,8°	0,97/ -8,8°
		100	0,72/ -46,9°	0,033/68,6°	13,5/149,7°	0,89/-19,6°
		200	0,62/ -81,4°	0,053/57,0°	10,5/128,5°	0,73/-30,3°
		500	0,48/-134,4°	0,079/52,6°	5,5/100,5°	0,51/-37,3°
		800	0,45/-159,8°	0,099/57,8°	3,6/ 85,6°	0,44/-37,9°
5	10	1000	0,44/-170,8°	0,114/61,0°	3,0/ 78,8°	0,42/-39,3°
		1200	0,43/ 179,8°	0,131/64,2°	2,5/ 72,9°	0,41/-40,9°
		40	0,63/ -29,7°	0,013/76,5°	24,4/161,0°	0,95/-13,5°
		100	0,56/ -66,2°	0,028/64,8°	20,0/139,4°	0,80/-17,8°
		200	0,47/-105,4°	0,042/57,8°	13,6/118,0°	0,59/-37,3°
		500	0,41/-152,0°	0,070/62,6°	6,4/ 94,8°	0,39/-39,0°
5	20	800	0,39/-171,7°	0,099/67,6°	4,1/ 82,7°	0,35/-38,2°
		1000	0,39/ 179,6°	0,119/69,1°	3,4/ 76,7°	0,34/-39,1°
		1200	0,39/ 171,6°	0,140/70,5°	2,8/ 71,5°	0,33/-40,7°
		40	0,47/ -44,2°	0,012/73,8°	35,2/154,0°	0,90/-19,2°
		100	0,42/ -90,7°	0,023/63,9°	25,4/129,3°	0,68/-35,0°
		200	0,39/-129,4°	0,034/62,9°	15,6/109,7°	0,47/-41,0°
5	30	500	0,37/-165,1°	0,067/70,5°	6,8/ 90,9°	0,32/-38,4°
		800	0,37/ 179,5°	0,101/73,2°	4,4/ 80,3°	0,29/-37,4°
		1000	0,36/ 173,0°	0,124/73,4°	3,6/ 75,4°	0,29/-38,3°
		1200	0,37/ 166,2°	0,148/73,6°	3,0/ 70,3°	0,28/-40,0°
		40	0,39/ -56,3°	0,011/72,3°	40,8/149,5°	0,86/-22,5°
		100	0,38/-106,8°	0,021/64,5°	27,4/124,0°	0,61/-37,9°
5	30	200	0,37/-141,6°	0,032/66,4°	16,0/105,8°	0,41/-41,1°
		500	0,37/-171,0°	0,067/73,5°	6,9/ 88,9°	0,29/-36,6°
		800	0,37/ 175,9°	0,102/75,2°	4,4/ 79,1°	0,27/-36,0°
		1000	0,36/ 170,0°	0,126/74,8°	3,6/ 74,2°	0,27/-37,1°
		1200	0,37/ 163,9°	0,150/74,6°	3,0/ 69,5°	0,27/-39,0°

s-parameters (common emitter)

V_{CE} V	I_C mA	f MHz	s_{ie}	s_{re}	s_{fe}	s_{oe}
8	2	40	0,90/ -12,2°	0,015/82,1°	6,9/171,7°	0,99/ -4,8°
		100	0,88/ -29,2°	0,036/74,5°	6,6/160,4°	0,96/ -10,8°
		200	0,81/ -54,7°	0,064/62,4°	5,9/143,1°	0,89/ -19,2°
		500	0,64/ -107,0°	0,103/44,9°	3,8/111,5°	0,71/ -30,6°
		800	0,56/ -138,1°	0,112/42,1°	2,7/ 92,2°	0,62/ -34,1°
		1000	0,54/ -152,6°	0,116/44,1°	2,3/ 83,6°	0,60/ -36,4°
		1200	0,52/ -165,2°	0,120/48,5°	1,9/ 75,9°	0,58/ -38,6°
8	5	40	0,78/ -19,2°	0,014/79,4°	14,8/166,9°	0,98/ -8,6°
		100	0,73/ -44,6°	0,032/69,0°	13,5/150,4°	0,90/ -18,7°
		200	0,63/ -78,1°	0,051/57,5°	10,5/129,4°	0,75/ -28,9°
		500	0,48/ -131,2°	0,077/52,5°	5,6/101,3°	0,53/ -35,7°
		800	0,44/ -157,3°	0,096/57,7°	3,7/ 86,3°	0,46/ -36,2°
		1000	0,42/ -168,3°	0,110/61,0°	3,0/ 79,5°	0,44/ -37,5°
		1200	0,42/ -178,3°	0,126/64,3°	2,6/ 73,6°	0,43/ -39,0°
8	10	40	0,66/ -27,7°	0,013/76,7°	24,0/161,5°	0,95/ -12,9°
		100	0,58/ -62,0°	0,027/65,4°	19,9/140,4°	0,81/ -26,3°
		200	0,48/ -100,1°	0,041/58,0°	13,8/119,0°	0,61/ -35,5°
		500	0,40/ -148,2°	0,068/62,2°	6,5/ 95,4°	0,42/ -37,0°
		800	0,38/ -169,1°	0,096/67,4°	4,2/ 83,0°	0,37/ -36,2°
		1000	0,37/ -178,3°	0,116/69,0°	3,4/ 77,4°	0,36/ -37,0°
		1200	0,37/ 173,6°	0,136/70,5°	2,9/ 72,5°	0,35/ -38,5°
8	20	40	0,53/ -39,6°	0,012/73,8°	34,7/154,8°	0,91/ -18,1°
		100	0,45/ -83,0°	0,023/63,9°	25,6/130,5°	0,70/ -33,2°
		200	0,39/ -122,0°	0,034/62,2°	15,9/110,6°	0,49/ -39,0°
		500	0,35/ -161,3°	0,066/69,7°	7,0/ 91,4°	0,34/ -36,2°
		800	0,35/ -177,9°	0,098/72,7°	4,5/ 80,7°	0,31/ -35,1°
		1000	0,34/ 175,2°	0,121/73,1°	3,7/ 75,8°	0,31/ -36,0°
		1200	0,34/ 168,3°	0,143/73,4°	3,1/ 71,2°	0,30/ -37,5°
8	30	40	0,47/ -48,0°	0,011/72,2°	40,3/150,8°	0,87/ -20,9°
		100	0,41/ -95,5°	0,021/63,8°	27,5/125,4°	0,63/ -35,7°
		200	0,36/ -132,8°	0,032/64,9°	16,4/106,8°	0,44/ -38,9°
		500	0,35/ -166,6°	0,065/72,3°	7,1/ 89,6°	0,32/ -34,4°
		800	0,34/ 178,8°	0,100/74,4°	4,5/ 79,7°	0,30/ -33,6°
		1000	0,34/ 172,7°	0,122/74,4°	3,7/ 74,7°	0,30/ -34,7°
		1200	0,34/ 166,0°	0,145/74,3°	3,1/ 70,3°	0,29/ -36,5°

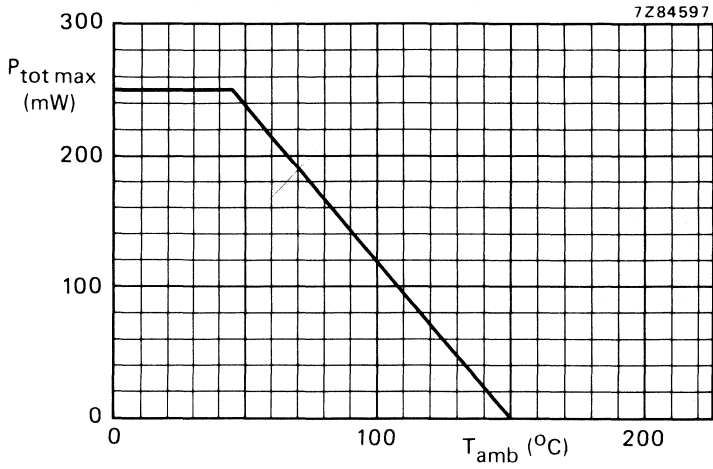

Fig. 3 Power derating curve.

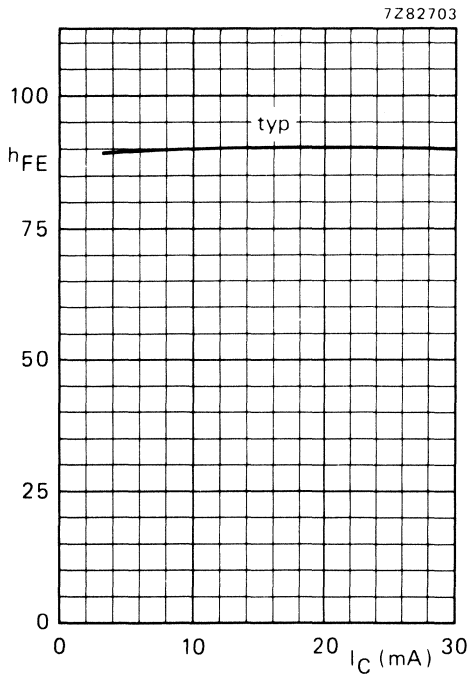

Fig. 4 $V_{CE} = 5\ V$; $T_j = 25\ ^\circ C$.

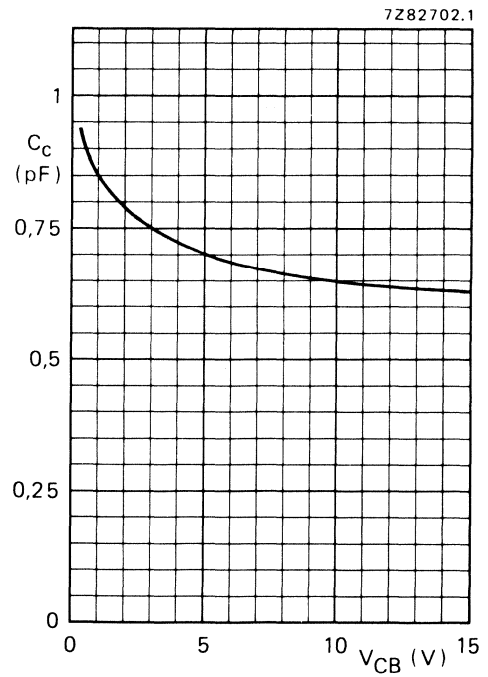

Fig. 5 Typical values collector capacitance
 $I_E = I_e = 0$; $f = 1\ MHz$; $T_j = 25\ ^\circ C$.

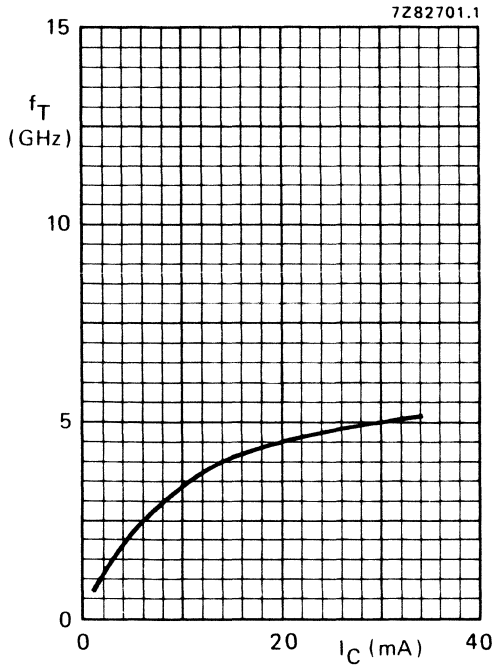

Fig. 6 Typical values transition frequency at $V_{CE} = 5$ V; $f = 500$ MHz; $T_j = 25$ °C.

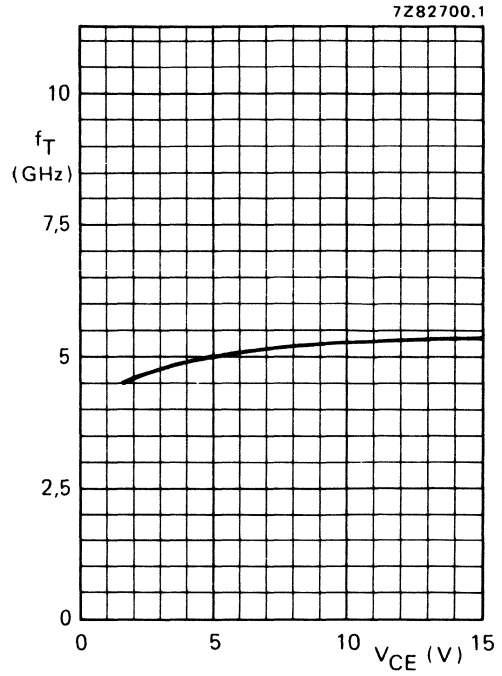

Fig. 7 Typical values transition frequency at $I_C = 30$ mA; $f = 500$ MHz; $T_j = 25$ °C.

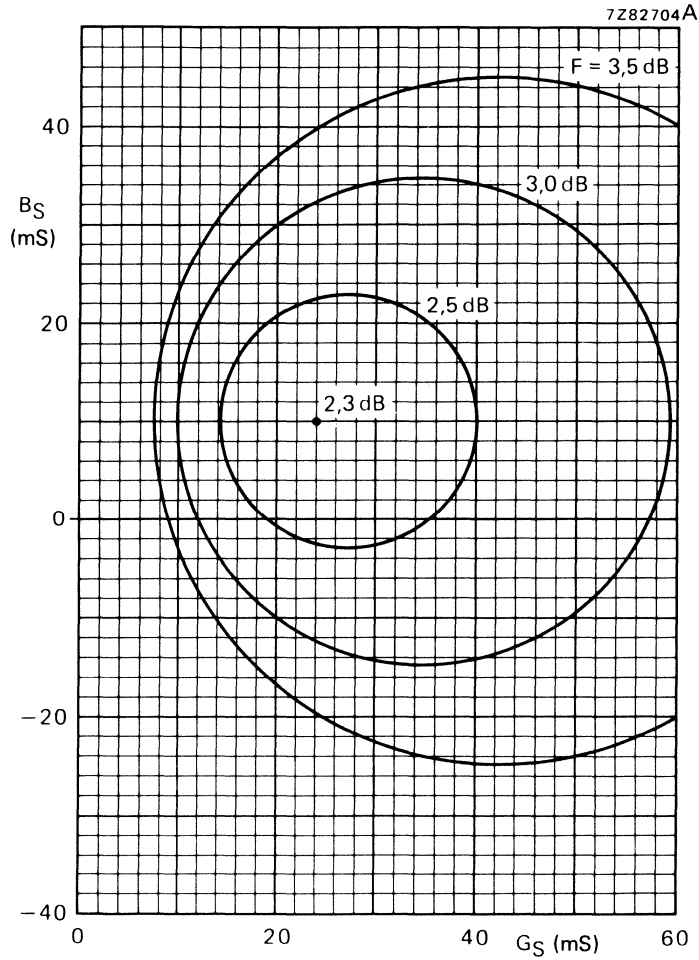

Fig. 8 Circles of constant noise figure.
 $V_{CE} = 8$ V; $I_C = 30$ mA; $f = 800$ MHz;
 $T_{amb} = 25$ °C; typical values.

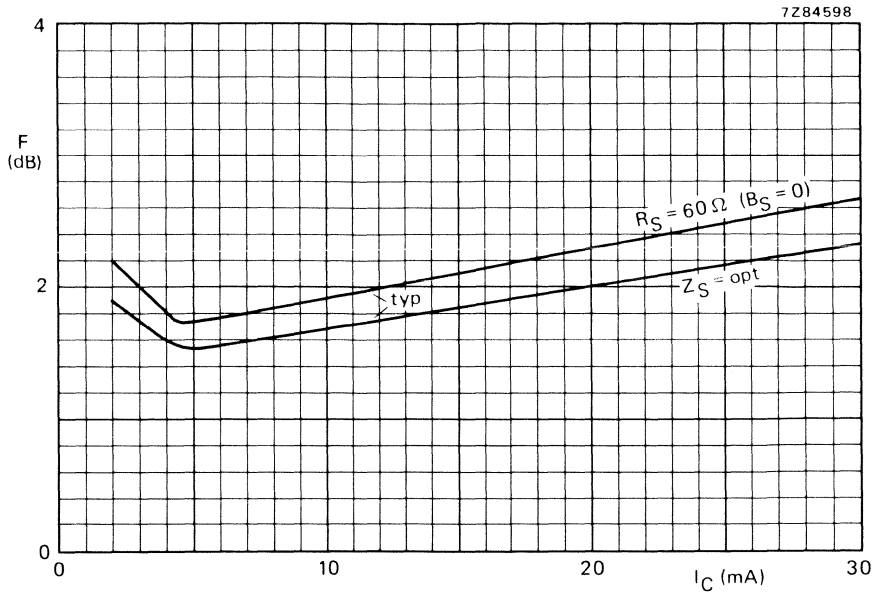

Fig. 9 $V_{CE} = 8 \text{ V}$; $f = 800 \text{ MHz}$; $T_{amb} = 25 \text{ }^\circ\text{C}$.

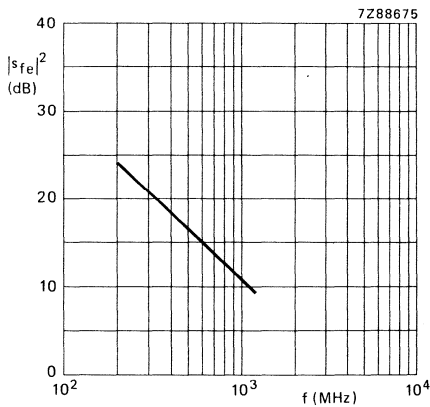

Fig. 10 Typical values forward transmission coefficient as a function of frequency. $V_{CE} = 8 \text{ V}$; $I_C = 30 \text{ mA}$; $T_{amb} = 25 \text{ }^\circ\text{C}$.

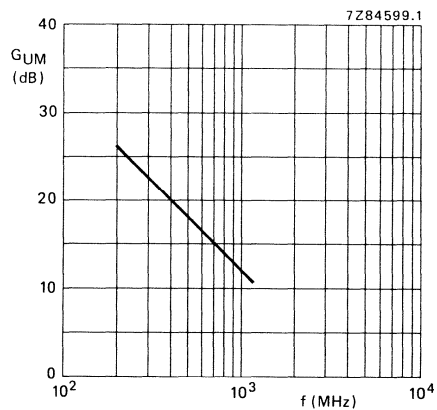

Fig. 11 Typical values unilateral power gain as a function of frequency. $V_{CE} = 8 \text{ V}$; $I_C = 30 \text{ mA}$; $T_{amb} = 25 \text{ }^\circ\text{C}$.

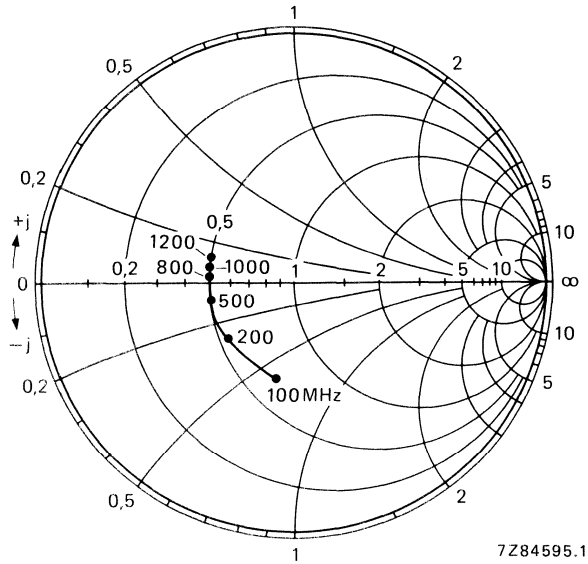

Fig. 12 Input impedance derived from input reflection coefficient s_{ie} co-ordinates in ohm $\times 50$.
 $V_{CE} = 8 \text{ V}$; $I_C = 30 \text{ mA}$; $T_{amb} = 25 \text{ }^\circ\text{C}$.

7Z84595.1

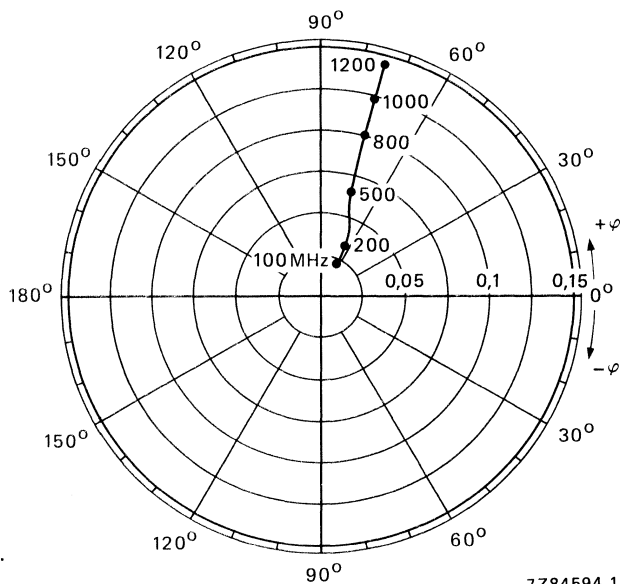

Fig. 13 Reverse transmission coefficient s_{re} .
 $V_{CE} = 8 \text{ V}$; $I_C = 30 \text{ mA}$; $T_{amb} = 25 \text{ }^\circ\text{C}$.

7Z84594.1

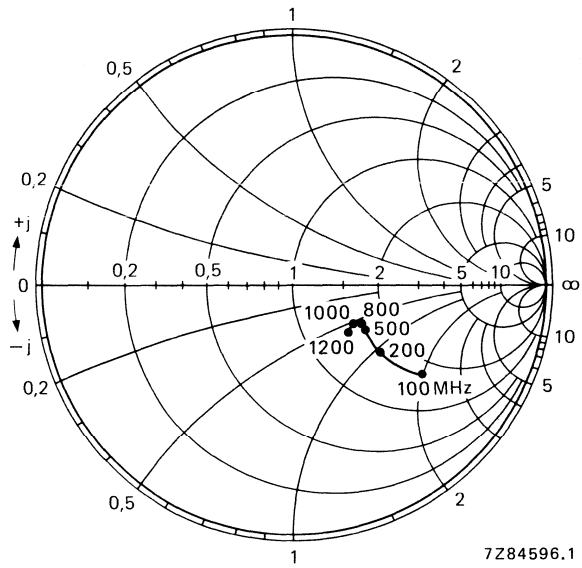

Fig. 14 Output impedance derived from output reflection coefficient s_{Oe} co-ordinates in ohm $\times 50$.
 $V_{CE} = 8 \text{ V}$; $I_C = 30 \text{ mA}$; $T_{amb} = 25 \text{ }^\circ\text{C}$.

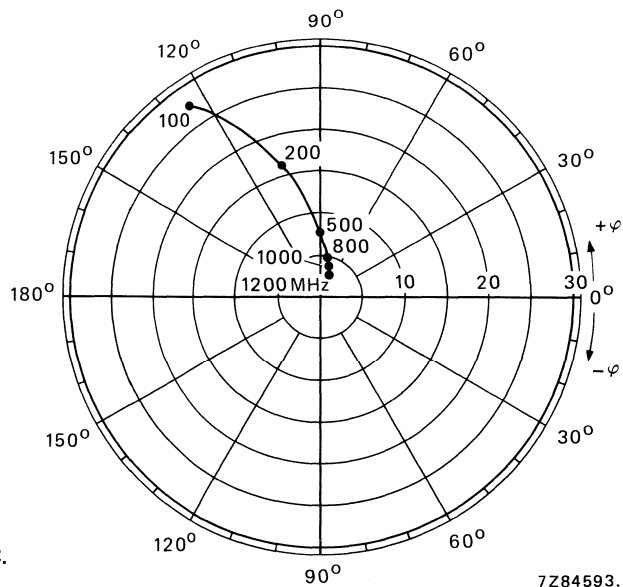

Fig. 15 Forward transmission coefficient s_{fe} .
 $V_{CE} = 8 \text{ V}$; $I_C = 30 \text{ mA}$; $T_{amb} = 25 \text{ }^\circ\text{C}$.

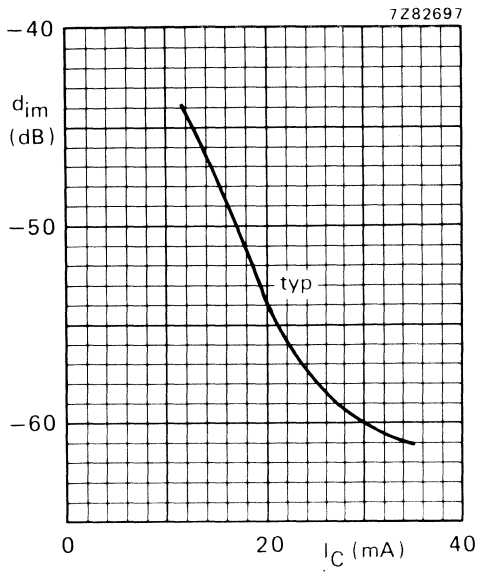

Fig. 16 $V_{CE} = 8 \text{ V}$; $V_O = 425 \text{ mV} = 52,6 \text{ dBmV}$;
 $f_{(p+q-r)} = 793,25 \text{ MHz}$; $T_{amb} = 25 \text{ }^\circ\text{C}$;
 measured in MATV test circuit (see Fig. 2).

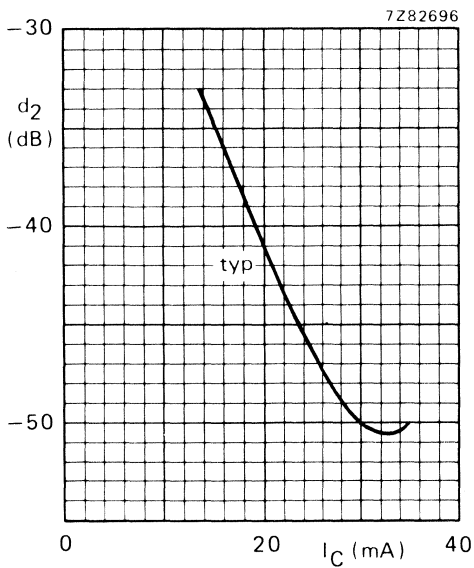

Fig. 17 $V_{CE} = 8 \text{ V}$; $V_O = 200 \text{ mV} = 46 \text{ dBmV}$;
 $f_{(p+q)} = 810 \text{ MHz}$; $T_{amb} = 25 \text{ }^\circ\text{C}$; measured in
 MATV test circuit (see Fig. 2).

N-CHANNEL JUNCTION FIELD-EFFECT TRANSISTOR

Symmetrical n-channel silicon junction field-effect transistor, designed primarily for use as a source follower with the input protected against successive voltage surges by a forward and reverse integrated diode.

QUICK REFERENCE DATA

Drain-source voltage	$\pm V_{DS}$	max.	30 V
Gate-source voltage (open drain)	$-V_{GS}$	max.	30 V
Total power dissipation up to $T_{amb} = 60\text{ }^{\circ}\text{C}$	P_{tot}	max.	200 mW
Drain current			
$V_{DS} = 6\text{ V}; V_{GS} = 0$: BFR101A	I_{DSS}		0,2 to 1,5 mA
$V_{DS} = 6\text{ V}; V_{GS} = 0$: BFR101B	I_{DSS}		1,0 to 5,0 mA
Transfer admittance (common source)			
$V_{DS} = 6\text{ V}; V_{GS} = 0; f = 1\text{ kHz}$: BFR101A	$ Y_{fs} $	>	1,2 mS
$V_{DS} = 6\text{ V}; V_{GS} = 0; f = 1\text{ kHz}$: BFR101B	$ Y_{fs} $	>	2,5 mS

MECHANICAL DATA

Fig. 1 SOT-143.

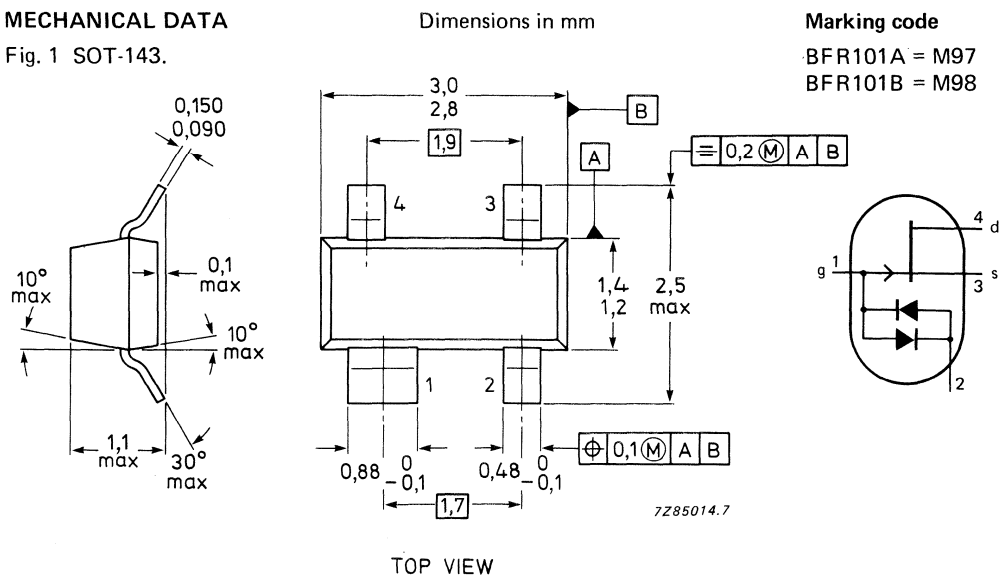

See also *Soldering recommendations*.

RATINGS

Limiting values in accordance with the Absolute Maximum System (IEC 134)

Drain-source voltage	$\pm V_{DS}$	max.	30 V
Drain-gate voltage (open source)	V_{DGO}	max.	30 V
Gate-source voltage (open drain)	$-V_{GSO}$	max.	30 V
Drain current (d.c.)	I_D	max.	20 mA
Gate current (d.c.)	I_G	max.	10 mA
Total power dissipation up to $T_{amb} = 60\text{ }^\circ\text{C}^*$	P_{tot}	max.	200 mW
Storage temperature	T_{stg}		-65 to +150 $^\circ\text{C}$
Junction temperature	T_j	max.	150 $^\circ\text{C}$

THERMAL RESISTANCE

From junction to ambient in free air*	$R_{th\ j-a}$	=	460 K/W
---------------------------------------	---------------	---	---------

CHARACTERISTICS with source connected to case for all measurements

$T_{amb} = 25\text{ }^\circ\text{C}$ unless otherwise specified

		BFR101A	BFR101B
Gate leakage current $V_{DS} = 6\text{ V}; I_D = 10\text{ }\mu\text{A}$	$-I_G$	< 5	5 nA
Drain current* $V_{DS} = 6\text{ V}; V_{GS} = 0$	I_{DSS}	0,2 to 1,5	1 to 5 mA
Gate-source cut-off voltage $V_{DS} = 6\text{ V}; I_D = 1\text{ }\mu\text{A}$	$-V_{(P)GS}$	0,2 to 1	0,5 to 2,5 V
Small-signal common-source characteristics $V_{DS} = 6\text{ V}; V_{GS} = 0$			
Transfer admittance* $f = 1\text{ kHz}$	$ y_{fs} $	> 1,2	2,5 mS
Output admittance at $f = 1\text{ kHz}^{**}$	$ y_{os} $	typ. 10	50 mS
Input capacitance at $f = 1\text{ MHz}$ diodes not connected	C_{is}	< 5	5 pF
Diode capacitance $V_D = 0$; source and drain not connected	C_d	typ. 0,7	0,7 pF
Diode forward voltage $\pm I_F = 10\text{ mA}$	V_F	0,7 to 1,2	0,7 to 1,2 V

* Device mounted on a ceramic substrate of 8 mm x 10 mm x 0,7 mm.

** Measured under pulse conditions: $t_p = 100\text{ ms}; \delta \leq 0,1$.

N-P-N H.F. WIDEBAND TRANSISTOR

N-P-N transistor in a plastic SOT-23 envelope. It is intended for a wide range of v.h.f. and u.h.f. applications in thick and thin-film circuits.

QUICK REFERENCE DATA

Collector-base voltage (open emitter; peak value)	V_{CBOM}	max.	25 V
Collector-emitter voltage (open base)	V_{CEO}	max.	15 V
Collector current (peak value)	I_{CM}	max.	50 mA
Total power dissipation up to $T_{amb} = 65\text{ }^{\circ}\text{C}$	P_{tot}	max.	250 mW
Junction temperature	T_j	max.	175 $^{\circ}\text{C}$
D.C. current gain $I_C = 2\text{ mA}; V_{CE} = 1\text{ V}$	h_{FE}		20 to 150
Transition frequency $I_C = 25\text{ mA}; V_{CE} = 5\text{ V}; f = 500\text{ MHz}$	f_T	typ.	1,3 GHz
Noise figure $I_C = 2\text{ mA}; V_{CE} = 5\text{ V}; R_S = 50\text{ }\Omega; f = 500\text{ MHz}$	F	typ.	4,5 dB

MECHANICAL DATA

Fig. 1 SOT-23.

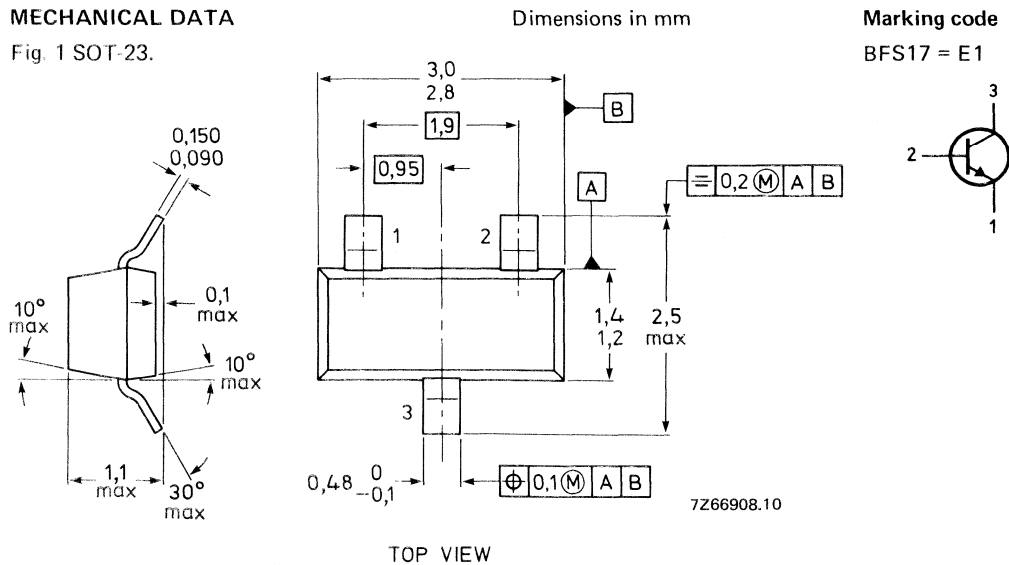

If required, the R-version (reverse pinning) is available on request.

RATINGS

Limiting values in accordance with the Absolute Maximum System (IEC 134)

Collector-base voltage (open emitter; peak value)	V_{CBOM}	max.	25 V
Collector-emitter voltage (open base) $I_C = 10 \text{ mA}$	V_{CEO}	max.	15 V
Emitter-base voltage (open collector)	V_{EBO}	max.	2,5 V
Collector current (d.c.)	I_C	max.	25 mA
Collector current (peak value)	I_{CM}	max.	50 mA
Total power dissipation up to $T_{amb} = 65 \text{ }^\circ\text{C}^{**}$	P_{tot}	max.	250 mW
Storage temperature	T_{stg}		-65 to +175 $^\circ\text{C}$
Junction temperature	T_j	max.	175 $^\circ\text{C}$

THERMAL CHARACTERISTICS*

$$T_j = P (R_{th\ j-t} + R_{th\ t-s} + R_{th\ s-a}) + T_{amb}$$

Thermal resistance

From junction to tab	$R_{th\ j-t}$	=	60 K/W
From tab to soldering points	$R_{th\ t-s}$	=	280 K/W
From soldering points to ambient**	$R_{th\ s-a}$	=	90 K/W

CHARACTERISTICS $T_j = 25 \text{ }^\circ\text{C}$ unless otherwise specified

Collector cut-off current

$I_E = 0; V_{CB} = 10 \text{ V}$

I_{CBO} max. 10 nA

$I_E = 0; V_{CB} = 10 \text{ V}; T_j = 100 \text{ }^\circ\text{C}$

I_{CBO} max. 10 μA

D.C. current gain

$I_C = 2 \text{ mA}; V_{CE} = 1 \text{ V}$

h_{FE} 20 to 150

$I_C = 25 \text{ mA}; V_{CE} = 1 \text{ V}$

h_{FE} min. 20

Transition frequency

$I_C = 2 \text{ mA}; V_{CE} = 5 \text{ V}; f = 500 \text{ MHz}$

f_T typ. 1,0 GHz

$I_C = 25 \text{ mA}; V_{CE} = 5 \text{ V}; f = 500 \text{ MHz}$

f_T typ. 1,3 GHz

Collector capacitance at $f = 1 \text{ MHz}$

$I_E = I_e = 0; V_{CB} = 10 \text{ V}$

C_C max. 1,5 pF

* See *Thermal characteristics*.

** Mounted on a ceramic substrate of 8 mm x 10 mm x 0,7 mm.

Emitter capacitance at $f = 1 \text{ MHz}$

$I_C = I_c = 0; V_{EB} = 0,5 \text{ V}$

C_e max. 2,0 pF

Feedback capacitance at $f = 1 \text{ MHz}$

$I_C = 1 \text{ mA}; V_{CE} = 5 \text{ V}$

C_{re} typ. 0,65 pF

Noise figure*

$I_C = 2 \text{ mA}; V_{CE} = 5 \text{ V};$

$f = 500 \text{ MHz}; R_S = 50 \Omega$

F typ. 4,5 dB

Intermodulation distortion

$I_C = 10 \text{ mA}; V_{CE} = 6 \text{ V}; R_L = 37,5 \Omega; T_{amb} = 25 \text{ }^\circ\text{C}$

$V_o = 100 \text{ mV}$ at $f_p = 183 \text{ MHz}$

$V_o = 100 \text{ mV}$ at $f_q = 200 \text{ MHz}$

measured at $f(2q-p) = 217 \text{ MHz}$

d_{im} typ. -45 dB

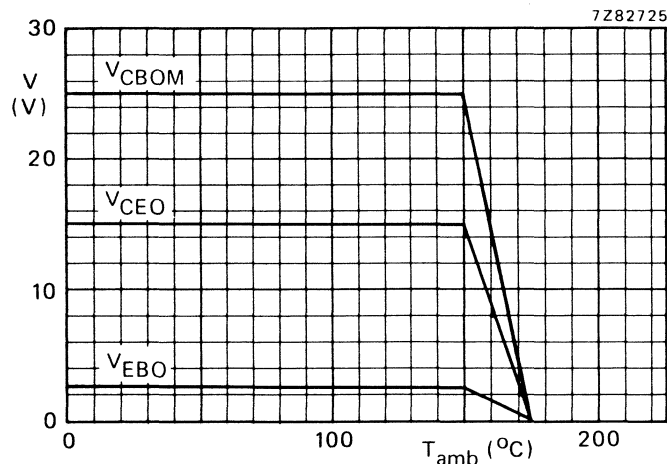

Fig. 2 Voltage derating curve.

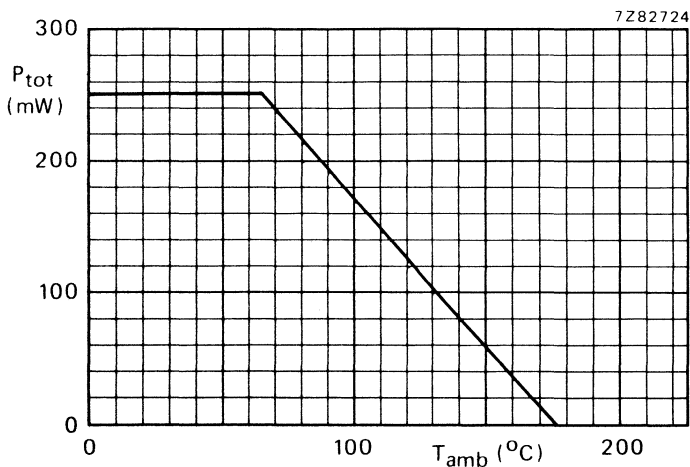

Fig. 3 Power derating curve.

* Crystal mounted in a BFY90 envelope.

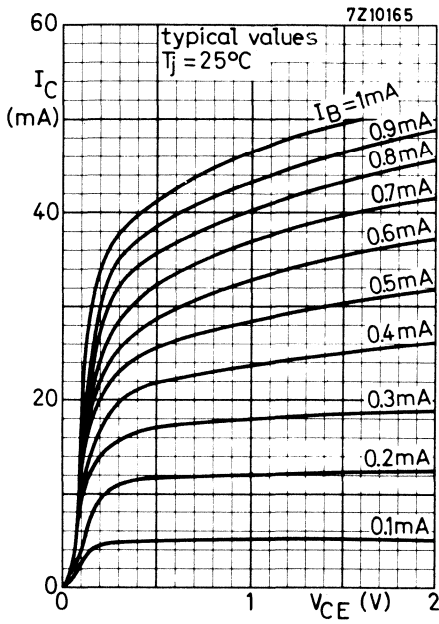

Fig. 4 $T_j = 25^\circ\text{C}$; typical values.

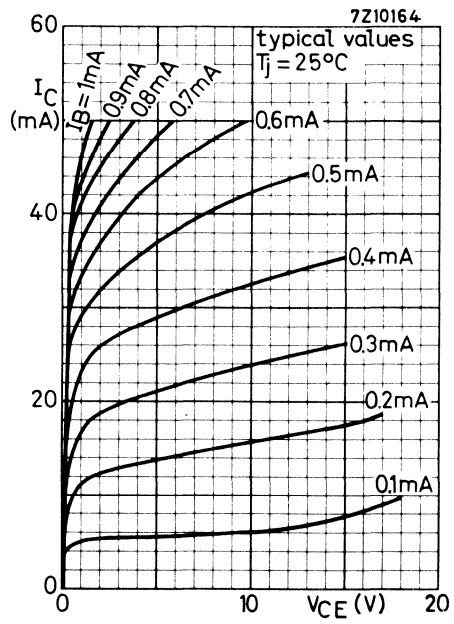

Fig. 5 $T_j = 25^\circ\text{C}$; typical values.

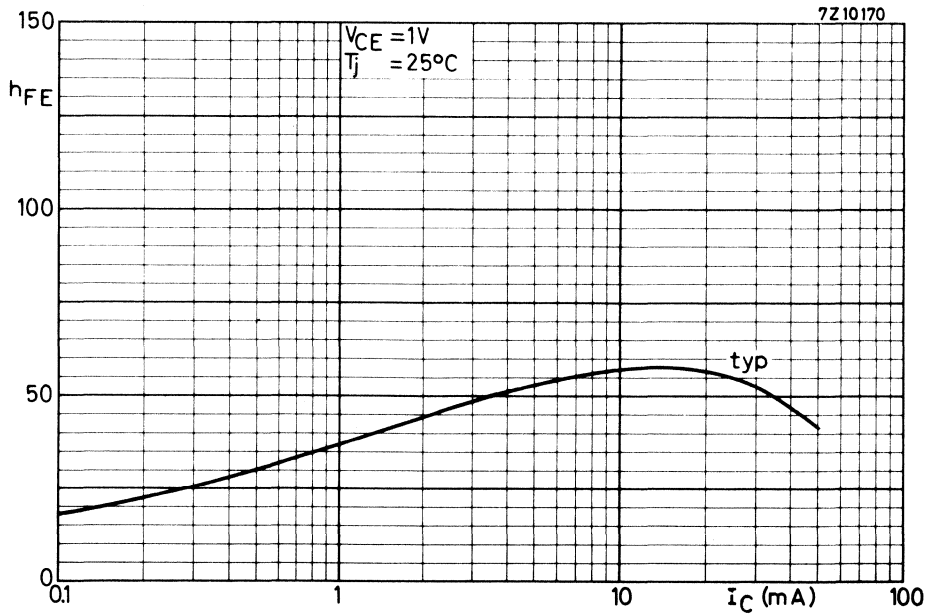

Fig. 6 $V_{CE} = 1\text{V}$; $T_j = 25^\circ\text{C}$; typical values.

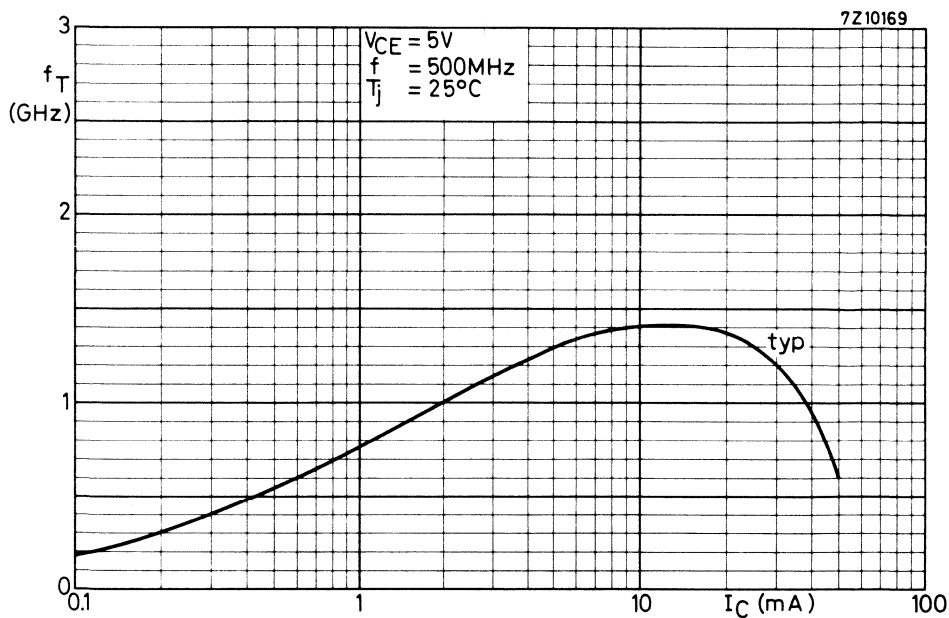

Fig. 7 $V_{CE} = 5 V$; $f = 500 MHz$; $T_j = 25^\circ C$; typical values.

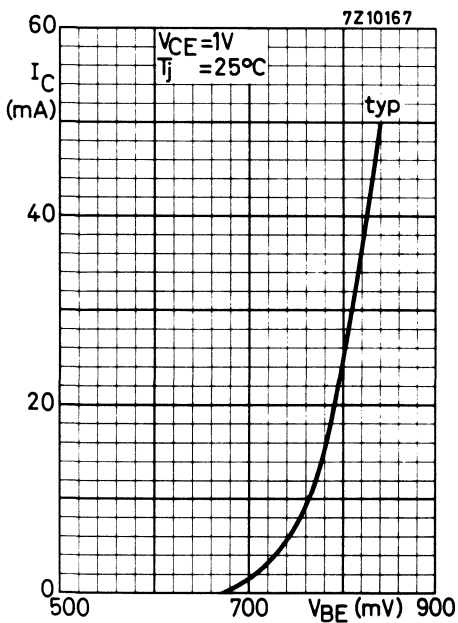

Fig. 8 $V_{CE} = 1 V$; $T_j = 25^\circ C$; typical values.

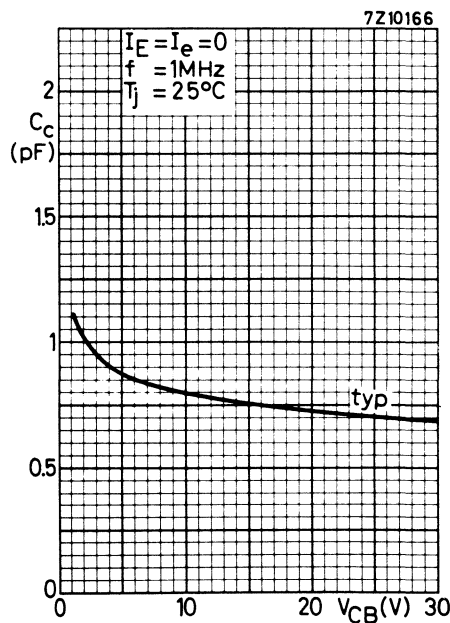

Fig. 9 $I_E = I_e = 0$; $f = 1 MHz$; $T_j = 25^\circ C$; typical values.

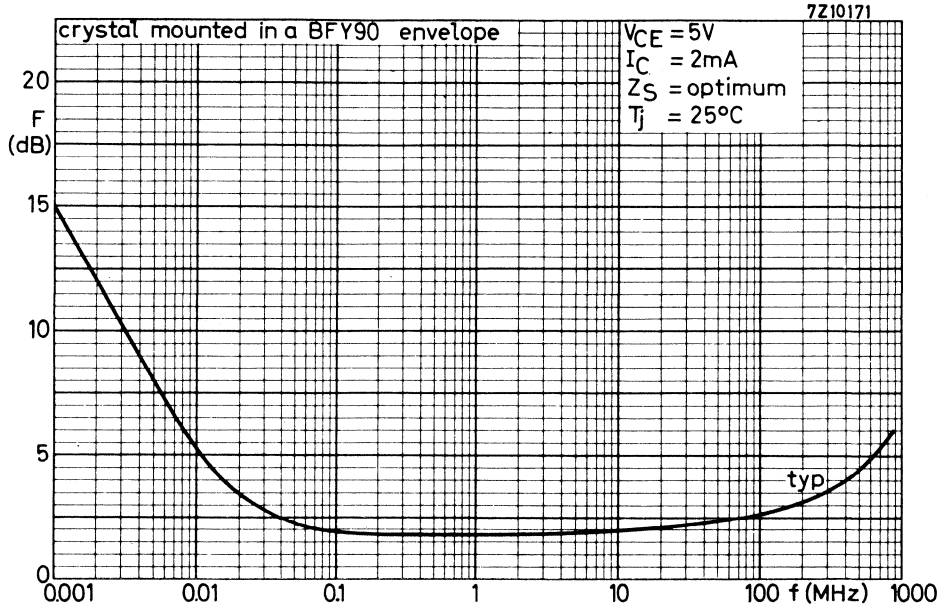

Fig. 10 $V_{CE} = 5V$; $I_C = 2mA$; $Z_S = \text{optimum}$; $T_j = 25^\circ C$; typical values.

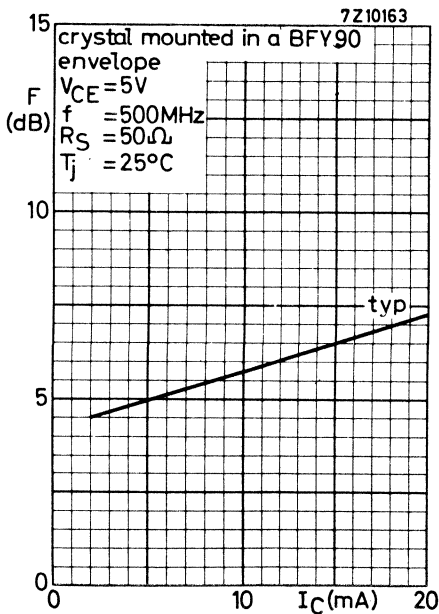

Fig. 11 $V_{CE} = 5V$; $f = 500MHz$; $R_S = 50\Omega$; $T_j = 25^\circ C$; typical values.

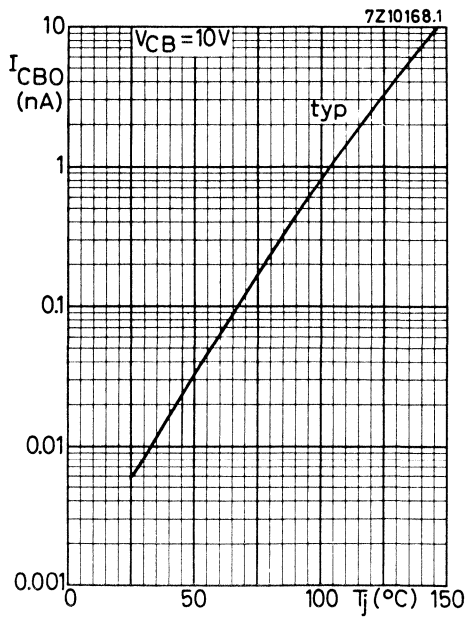

Fig. 12 $V_{CB} = 10V$; typical values.

SILICON PLANAR EPITAXIAL TRANSISTORS

N-P-N transistors in a microminiature plastic envelope. They are intended for general purpose and h.f. applications in thick and thin-film circuits.

QUICK REFERENCE DATA

Collector-base voltage (open emitter)	V_{CB0}	max.	30	V
Collector-emitter voltage (open base)	V_{CE0}	max.	20	V
Collector current (d.c.)	I_C	max.	30	mA
Total power dissipation up to $T_{amb} = 40\text{ }^\circ\text{C}$	P_{tot}	max.	250	mW
Junction temperature	T_j	max.	150	$^\circ\text{C}$

D.C. current gain			BFS18	BFS19	
$I_C = 1\text{ mA}; V_{CE} = 10\text{ V}$	h_{FE}		35 to 125	65 to 225	
Transition frequency at $f = 100\text{ MHz}$					
$I_C = 1\text{ mA}; V_{CE} = 10\text{ V}$	f_T	typ.	200	260	MHz
Noise figure at $f = 100\text{ MHz}$					
$I_C = 1\text{ mA}; V_{CE} = 10\text{ V}; G_S = 10\text{ mS}$	F	typ.	4		dB

MECHANICAL DATA

Fig. 1 SOT-23.

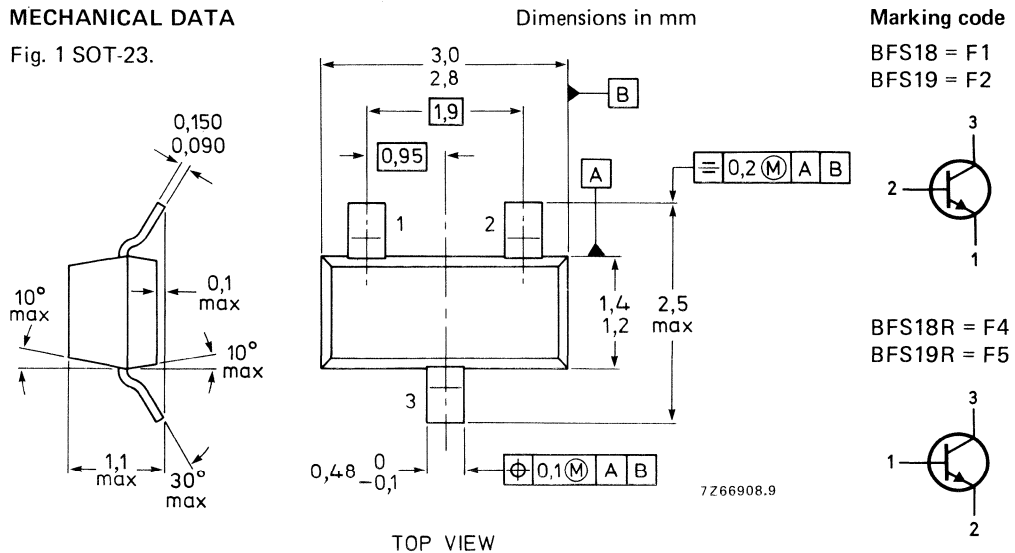

R-types are available on request.

See also *Soldering recommendations*.

RATINGS

Limiting values in accordance with the Absolute Maximum System (IEC 134)

Collector-base voltage (open emitter) See Fig. 2	V_{CBO}	max.	30	V
Collector-emitter voltage (open base) See Fig. 2 $I_C = 2 \text{ mA}$	V_{CEO}	max.	20	V
Emitter-base voltage (open collector) See Fig. 2	V_{EBO}	max.	5	V
Collector current (d.c.)	I_C	max.	30	mA
Collector current (peak value)	I_{CM}	max.	30	mA
Total power dissipation up to $T_{amb} = 40 \text{ }^\circ\text{C}^{**}$	P_{tot}	max.	250	mW
Storage temperature	T_{stg}		-65 to + 150	$^\circ\text{C}$
Junction temperature	T_j	max.	150	$^\circ\text{C}$

THERMAL CHARACTERISTICS*

$$T_j = P (R_{th j-t} + R_{th t-s} + R_{th s-a}) + T_{amb}$$

Thermal resistance

From junction to tab	$R_{th j-t}$	=	60	K/W
From tab to soldering points	$R_{th t-s}$	=	280	K/W
From soldering points to ambient**	$R_{th s-a}$	=	90	K/W

CHARACTERISTICS

$T_j = 25 \text{ }^\circ\text{C}$ unless otherwise specified

Collector cut-off current

$$I_E = 0; V_{CB} = 20 \text{ V} \quad I_{CBO} < \begin{matrix} 100 \\ 10 \end{matrix} \begin{matrix} \text{nA} \\ \mu\text{A} \end{matrix}$$

$$I_E = 0; V_{CB} = 20 \text{ V}; T_j = 100 \text{ }^\circ\text{C} \quad I_{CBO} < \begin{matrix} 100 \\ 10 \end{matrix} \begin{matrix} \text{nA} \\ \mu\text{A} \end{matrix}$$

Base-emitter voltage

$$I_C = 1 \text{ mA}; V_{CE} = 10 \text{ V} \quad V_{BE} \quad 0,65 \text{ to } 0,74 \quad \text{V}$$

D.C. current gain

		<u>BFS18</u>	<u>BFS19</u>	
$I_C = 1 \text{ mA}; V_{CE} = 10 \text{ V}$	h_{FE}	35 to 125	65 to 225	

Transition frequency at $f = 100 \text{ MHz}$

$I_C = 1 \text{ mA}; V_{CE} = 10 \text{ V}$	f_T	typ.	200	260	MHz
---	-------	------	-----	-----	-----

Collector capacitance at $f = 1 \text{ MHz}$

$I_E = I_e = 0; V_{CB} = 10 \text{ V}$	C_c	typ.	1	pF
--	-------	------	---	----

Feedback capacitance at $f = 1 \text{ MHz}$

$I_C = 1 \text{ mA}; V_{CE} = 10 \text{ V}$	$-C_{re}$	typ.	0,85	pF
---	-----------	------	------	----

Noise figure ▲

$I_C = 1 \text{ mA}; V_{CE} = 10 \text{ V};$ $G_S = 10 \text{ mS}; f = 100 \text{ MHz}$	F	typ.	4	dB
--	---	------	---	----

* See *Thermal characteristics*.

** Mounted on a ceramic substrate of 8 mm x 10 mm x 0,7 mm.

▲ Crystal mounted in a BF115 enve

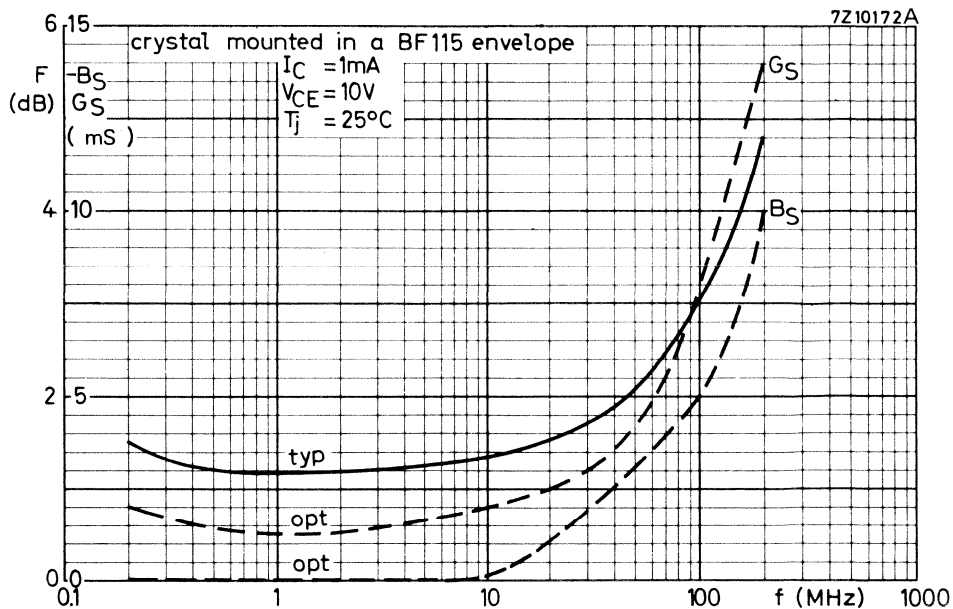

Fig. 2.

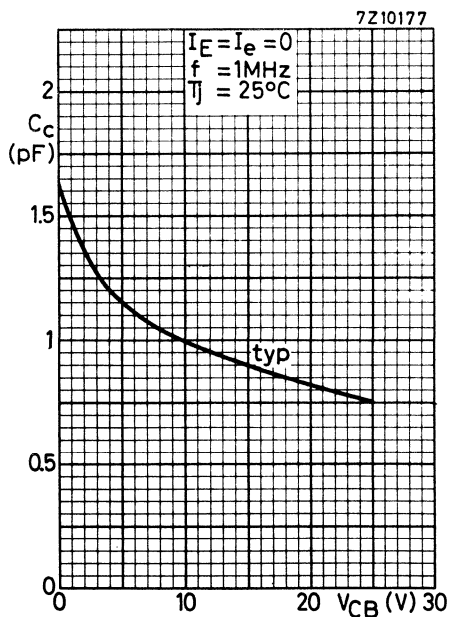

Fig. 3.

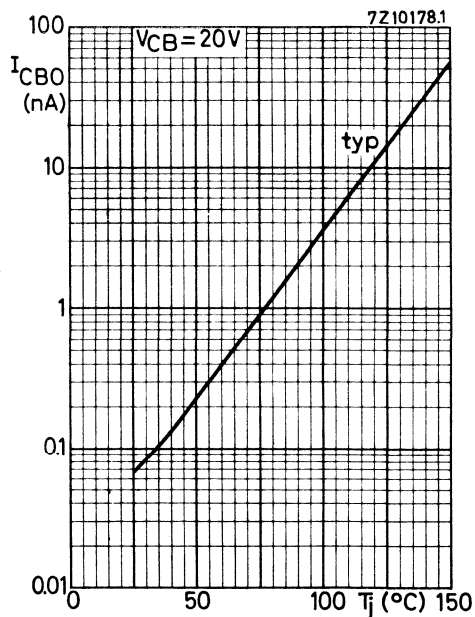

Fig. 4.

Typical behaviour of collector current versus collector-emitter voltage

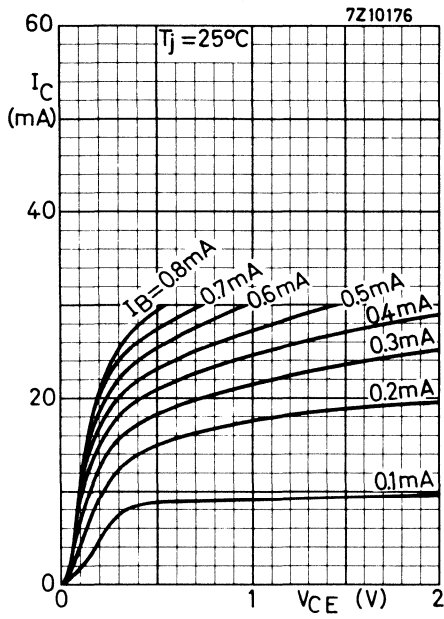

Fig. 5.

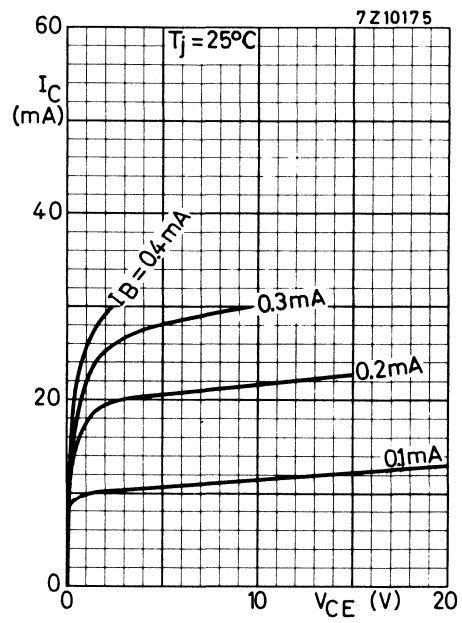

Fig. 6.

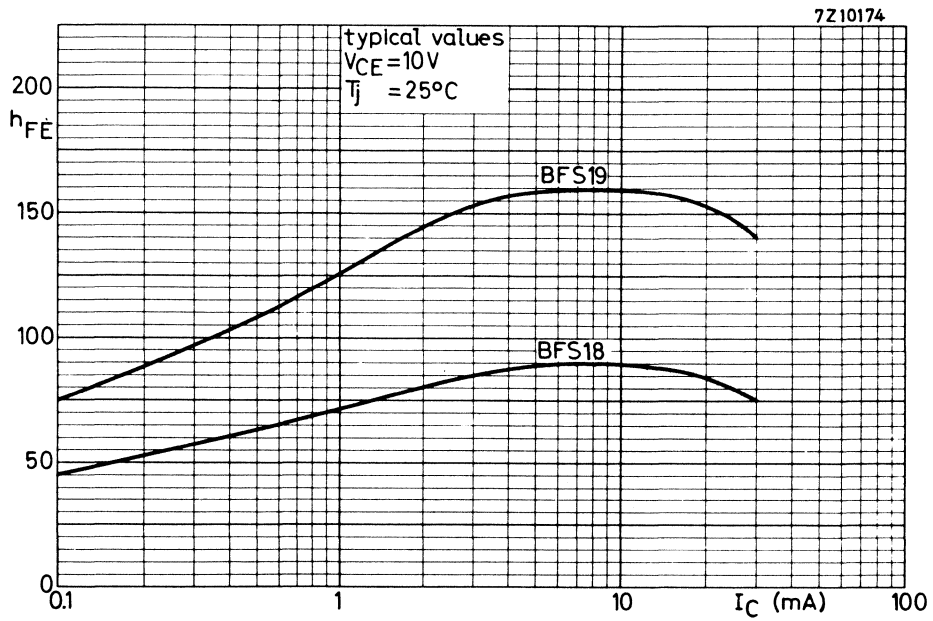

Fig. 7.

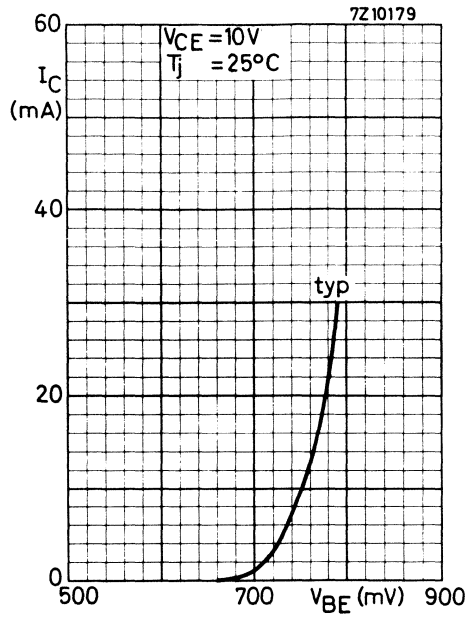

Fig. 8.

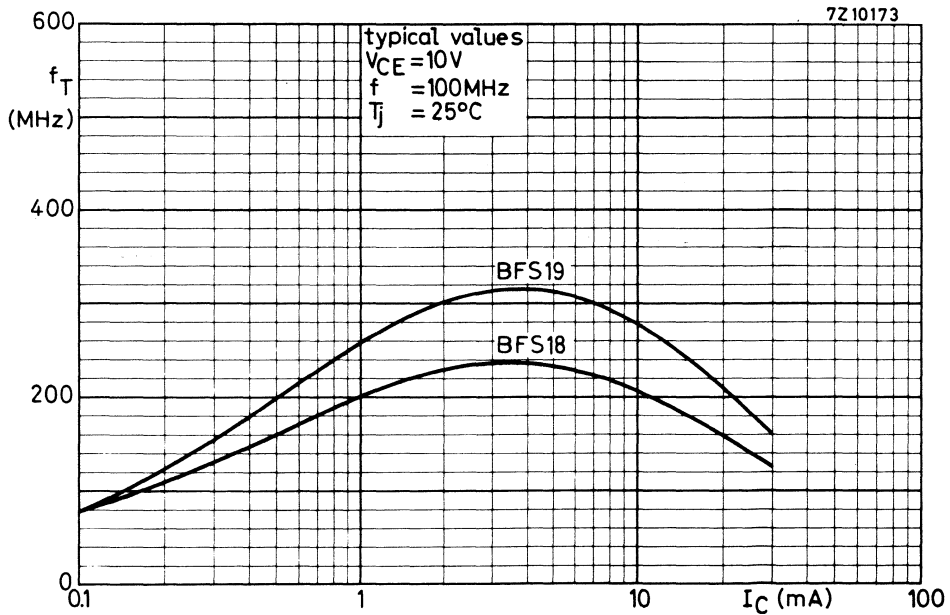

Fig. 9.

SILICON PLANAR EPITAXIAL TRANSISTORS

N-P-N transistor in a microminiature plastic envelope. It has a very low feedback capacitance and is intended for i.f. and v.h.f. applications in thick and thin-film circuits.

QUICK REFERENCE DATA

Collector-base voltage (open emitter)	V_{CBO}	max.	30 V
Collector-emitter voltage (open base)	V_{CEO}	max.	20 V
Collector current (d.c.)	I_C	max.	25 mA
Total power dissipation up to $T_{amb} = 40\text{ }^\circ\text{C}$	P_{tot}	max.	250 mW
Junction temperature	T_j	max.	150 $^\circ\text{C}$
D.C. current gain	h_{FE}	>	40
$I_C = 7\text{ mA}; V_{CE} = 10\text{ V}$			
Transition frequency at $f = 100\text{ MHz}$	f_T	typ.	450 MHz
$I_C = 5\text{ mA}; V_{CE} = 5\text{ V}$			
Feedback capacitance at $f = 1\text{ MHz}$	C_{re}	typ.	350 fF
$I_C = 1\text{ mA}; V_{CE} = 10\text{ V}$			

MECHANICAL DATA

Fig. 1 SOT-23.

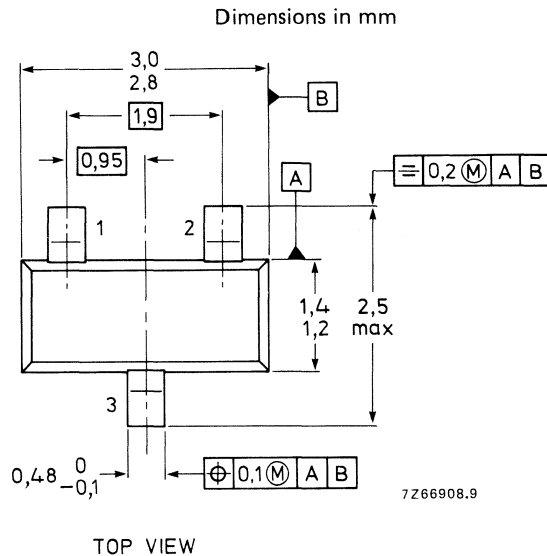
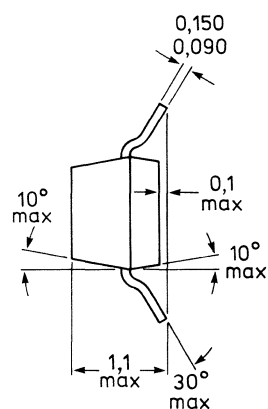

Marking code

BFS20 = G1

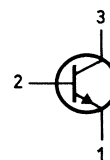

BFS20R = G4

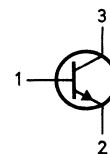

R-types are available on request

See also *Soldering recommendations*.

RATINGS

Limiting values in accordance with the Absolute Maximum System (IEC 134)

Collector-base voltage (open emitter) see Fig. 2	V_{CB0}	max.	30 V
Collector-emitter voltage (open base) see Fig. 2 $I_C = 2 \text{ mA}$	V_{CEO}	max.	20 V
Emitter-base voltage (open collector) see Fig. 2	V_{EBO}	max.	4 V
Collector current (d.c.)	I_C	max.	25 mA
Collector current (peak value)	I_{CM}	max.	25 mA
Total power dissipation up to $T_{amb} = 40 \text{ }^\circ\text{C}^{**}$	P_{tot}	max.	250 mW
Storage temperature	T_{stg}		-65 to +150 $^\circ\text{C}$
Junction temperature	T_j	max.	150 $^\circ\text{C}$

THERMAL CHARACTERISTICS *

$$T_j = P \times (R_{th\ j-t} + R_{th\ t-s} + R_{th\ s-a}) + T_{amb}$$

Thermal resistance

From junction to tab	$R_{th\ j-t}$	=	60 K/W
From tab to soldering points	$R_{th\ t-s}$	=	280 K/W
From soldering points to ambient **	$R_{th\ s-a}$	=	90 K/W

CHARACTERISTICS $T_j = 25 \text{ }^\circ\text{C}$ unless otherwise specified

Collector cut-off current

$I_E = 0; V_{CB} = 20 \text{ V}$

$I_{CBO} < 100 \text{ nA}$

$I_E = 0; V_{CB} = 20 \text{ V}; T_j = 100 \text{ }^\circ\text{C}$

$I_{CBO} < 10 \text{ } \mu\text{A}$

Base-emitter voltage

$I_C = 7 \text{ mA}; V_{CE} = 10 \text{ V}$

V_{BE} typ. 740 mV
< 900 mV

D.C. current gain

$I_C = 7 \text{ mA}; V_{CE} = 10 \text{ V}$

h_{FE} > 40
typ. 85

Transition frequency at $f = 100 \text{ MHz}$

$I_C = 5 \text{ mA}; V_{CE} = 10 \text{ V}$

f_T > 275 MHz
typ. 450 MHz

Collector capacitance at $f = 1 \text{ MHz}$

$I_E = I_e = 0; V_{CB} = 10 \text{ V}$

C_c typ. 0,8 pF

Feedback capacitance at $f = 1 \text{ MHz}$

$I_C = 1 \text{ mA}; V_{CE} = 10 \text{ V}$

$-C_{re}$ typ. 350 fF

* See *Thermal characteristics*.

** Mounted on a ceramic substrate of 8 mm x 10 mm x 0,7 mm.

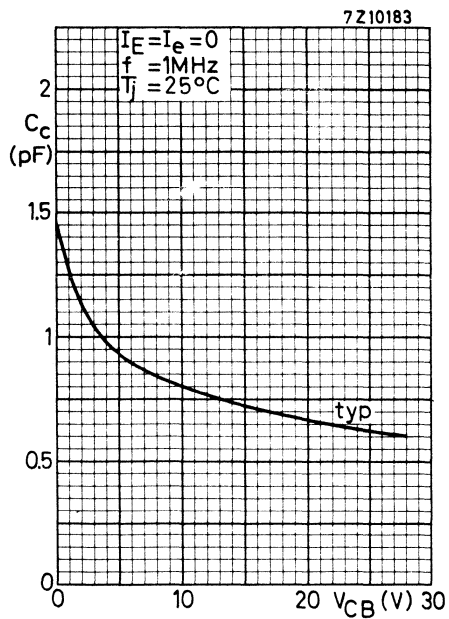

Fig. 2.

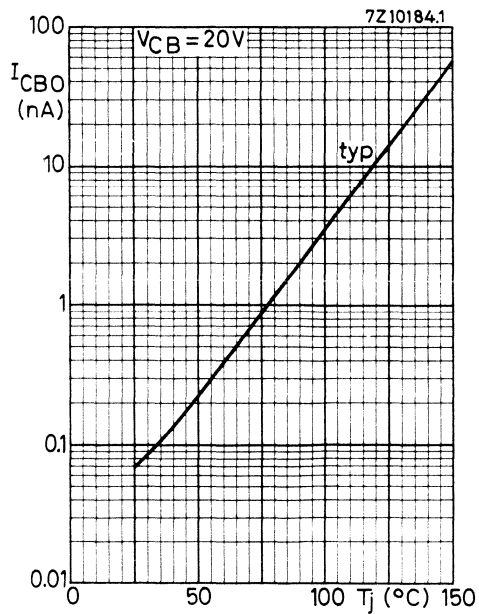

Fig. 3.

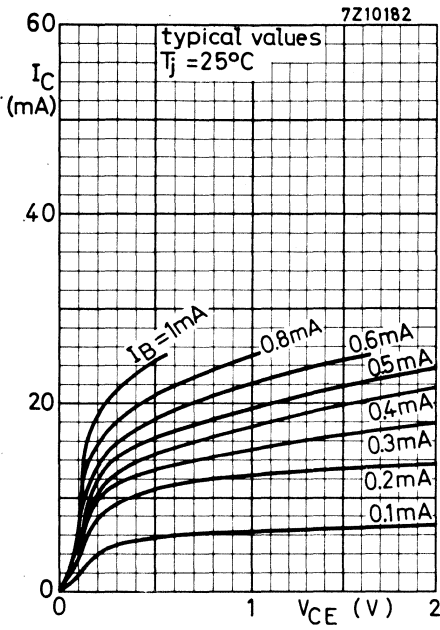

Fig. 4.

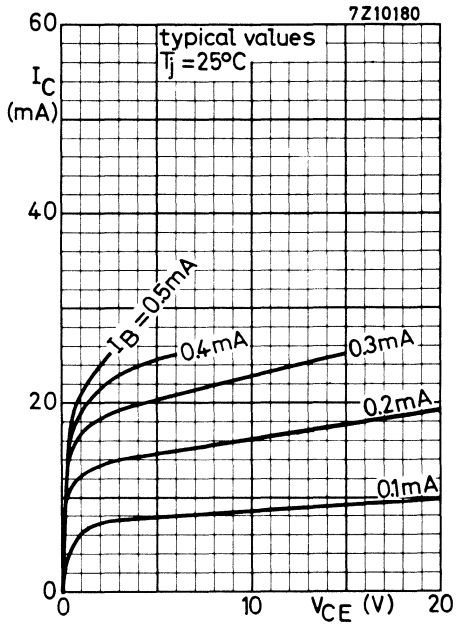

Fig. 5.

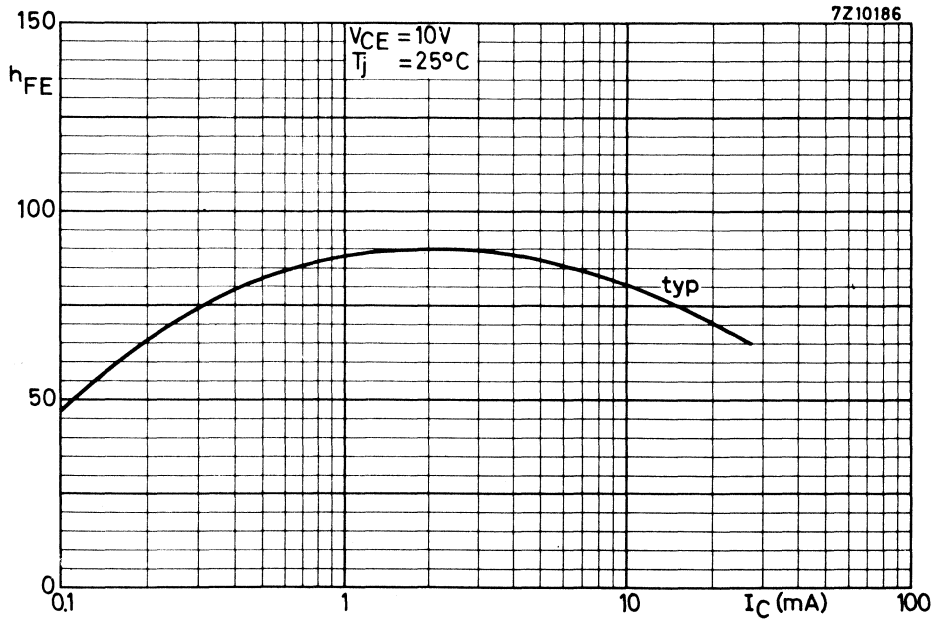

Fig. 6.

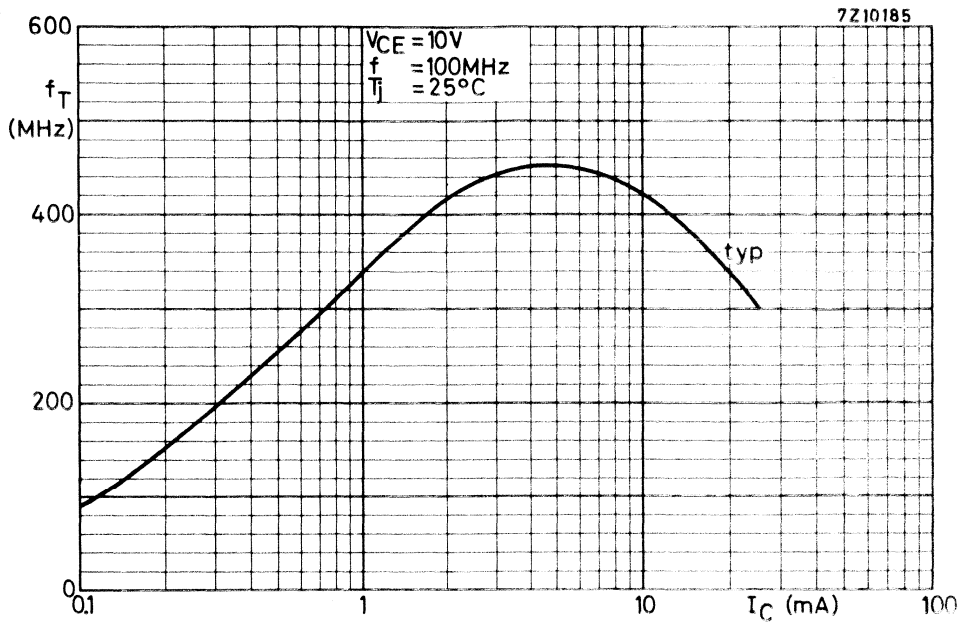

Fig. 7.

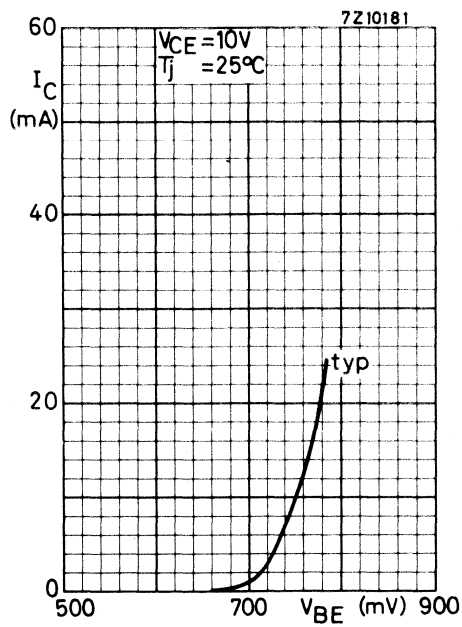

Fig. 8.

N-P-N H.F. WIDEBAND TRANSISTOR

N-P-N transistor in a plastic SOT-23 envelope, primarily intended for use in u.h.f. low power amplifiers in thick and thin-film circuits, such as in pocket phones, paging systems, etc. The transistor features low current consumption ($100 \mu\text{A} - 1 \text{ mA}$); thanks to its high transition frequency, it also has excellent wideband properties and low noise up to high frequencies.

QUICK REFERENCE DATA

Collector-base voltage (open emitter)	V_{CBO}	max.	8 V
Collector-emitter voltage (open base)	V_{CEO}	max.	5 V
Collector current (d.c.)	I_{C}	max.	6,5 mA
Total power dissipation up to $T_{\text{amb}} = 125 \text{ }^\circ\text{C}$	P_{tot}	max.	50 mW
Junction temperature	T_{j}	max.	150 $^\circ\text{C}$
Transition frequency at $f = 500 \text{ MHz}$ $I_{\text{C}} = 1 \text{ mA}; V_{\text{CE}} = 1 \text{ V}$	f_{T}	typ.	2,3 GHz
Feedback capacitance at $f = 1 \text{ MHz}$ $I_{\text{C}} = 1 \text{ mA}; V_{\text{CE}} = 1 \text{ V}$	C_{re}	max.	0,45 pF
Noise figure at optimum source impedance $I_{\text{C}} = 1 \text{ mA}; V_{\text{CE}} = 1 \text{ V}; f = 500 \text{ MHz}$	F	typ.	3,8 dB
Max. unilateral power gain $I_{\text{C}} = 1 \text{ mA}; V_{\text{CE}} = 1 \text{ V}; f = 500 \text{ MHz}$	GUM	typ.	18 dB

MECHANICAL DATA

Fig. 1 SOT-23.

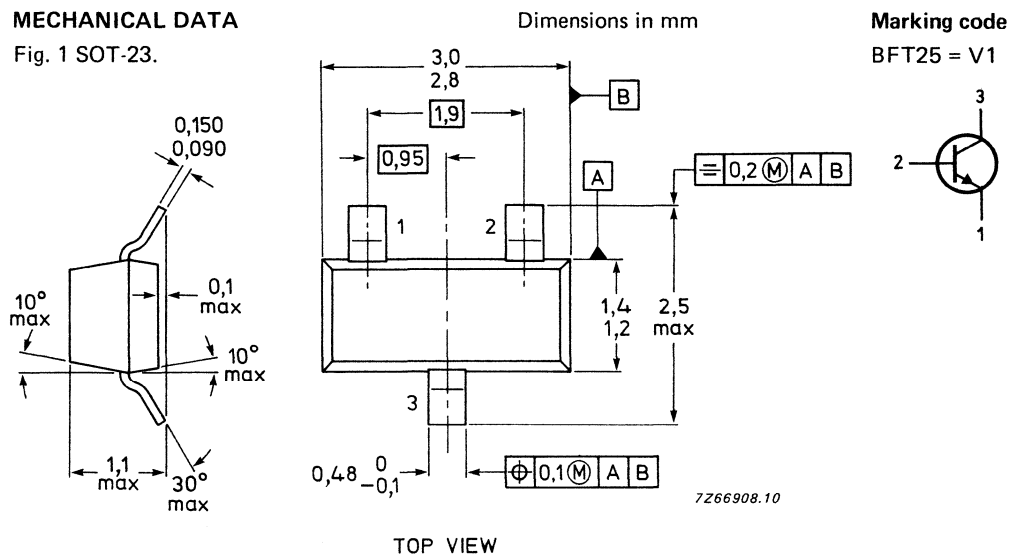

If required, the R-version (reverse pinning) is available on request.

RATINGS

Limiting values in accordance with the Absolute Maximum System (IEC 134)

Collector-base voltage (open emitter)	V _{CB0}	max.	8 V
Collector-emitter voltage (open base)	V _{CE0}	max.	5 V
Emitter-base voltage (open collector)	V _{EBO}	max.	2 V
Collector current (d.c.)	I _C	max.	6,5 mA
Collector current (peak value; f > 1 MHz)	I _{CM}	max.	10 mA
Total power dissipation up to T _{amb} = 125 °C**	P _{tot}	max.	50 mW
Storage temperature	T _{stg}		-65 to + 150 °C
Junction temperature	T _j	max.	150 °C

THERMAL CHARACTERISTICS*

$$T_j = P \times (R_{thj-t} + R_{tht-s} + R_{th s-a}) + T_{amb}$$

Thermal resistance

From junction to tab	R _{thj-t}	=	60 K/W
From tab to soldering points	R _{tht-s}	=	280 K/W
From soldering points to ambient**	R _{th s-a}	=	90 K/W

CHARACTERISTICS

T_j = 25 °C unless otherwise specified

Collector cut-off current

I _E = 0; V _{CB} = 5 V	I _{CB0}	max.	50 nA
---	------------------	------	-------

D.C. current gain

I _C = 10 μA; V _{CE} = 1 V	h _{FE}	min.	20
		typ.	30

I _C = 1 mA; V _{CE} = 1 V	h _{FE}	min.	20
		typ.	40

Saturation voltages

I _C = 10 μA; I _B = 1 μA	V _{CEsat}	max.	200 mV
	V _{BEsat}	max.	750 mV

I _C = 1 mA; I _B = 0.1 mA	V _{CEsat}	max.	175 mV
	V _{BEsat}	max.	900 mV

Transition frequency at f = 500 MHz

I _C = 1 mA; V _{CE} = 1 V	f _T	min.	1,2 GHz
		typ.	2,3 GHz

* See *Thermal characteristics*.

** Mounted on a ceramic substrate of 8 mm x 10 mm x 0,7 mm.

Collector capacitance at $f = 1 \text{ MHz}$

$$I_E = I_e = 0; V_{CB} = 0,5 \text{ V}$$

C_c max. 0,6 pF

Emitter capacitance at $f = 1 \text{ MHz}$

$$I_C = I_c = 0; V_{EB} = 0$$

C_e max. 0,5 pF

Feedback capacitance at $f = 1 \text{ MHz}$

$$I_C = 1 \text{ mA}; V_{CE} = 1 \text{ V}; T_{amb} = 25 \text{ }^\circ\text{C}$$

C_{re} max. 0,45 pF

Noise figure at optimum source impedance

$$I_C = 0,1 \text{ mA}; V_{CE} = 1 \text{ V}; f = 500 \text{ MHz}; T_{amb} = 25 \text{ }^\circ\text{C}$$

F typ. 5,5 dB

$$I_C = 1 \text{ mA}; V_{CE} = 1 \text{ V}; f = 500 \text{ MHz}; T_{amb} = 25 \text{ }^\circ\text{C}$$

F typ. 3,8 dB

Maximum unilateral power gain (s_{re} assumed to be zero)

$$G_{UM} \text{ (in dB)} = 10 \log \frac{|s_{fe}|^2}{(1 - |s_{ie}|^2)(1 - |s_{oe}|^2)}$$

$$I_C = 1 \text{ mA}; V_{CE} = 1 \text{ V}; f = 200 \text{ MHz}; T_{amb} = 25 \text{ }^\circ\text{C}$$

G_{UM} typ. 25,0 dB

$$I_C = 1 \text{ mA}; V_{CE} = 1 \text{ V}; f = 500 \text{ MHz}; T_{amb} = 25 \text{ }^\circ\text{C}$$

G_{UM} typ. 18,0 dB

$$I_C = 1 \text{ mA}; V_{CE} = 1 \text{ V}; f = 800 \text{ MHz}; T_{amb} = 25 \text{ }^\circ\text{C}$$

G_{UM} typ. 12,0 dB

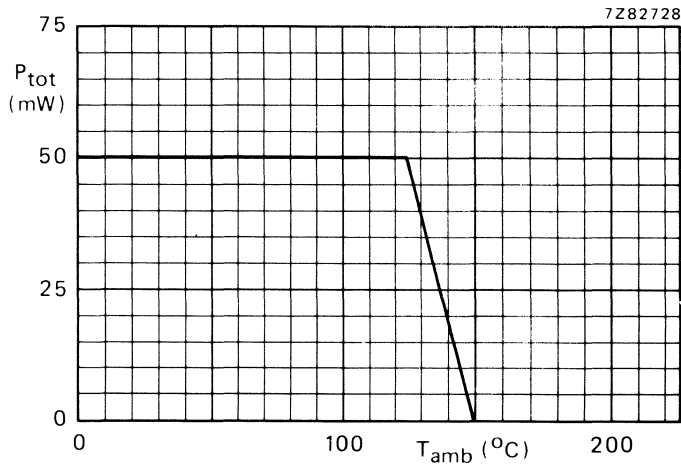

Fig. 2 Power derating curve.

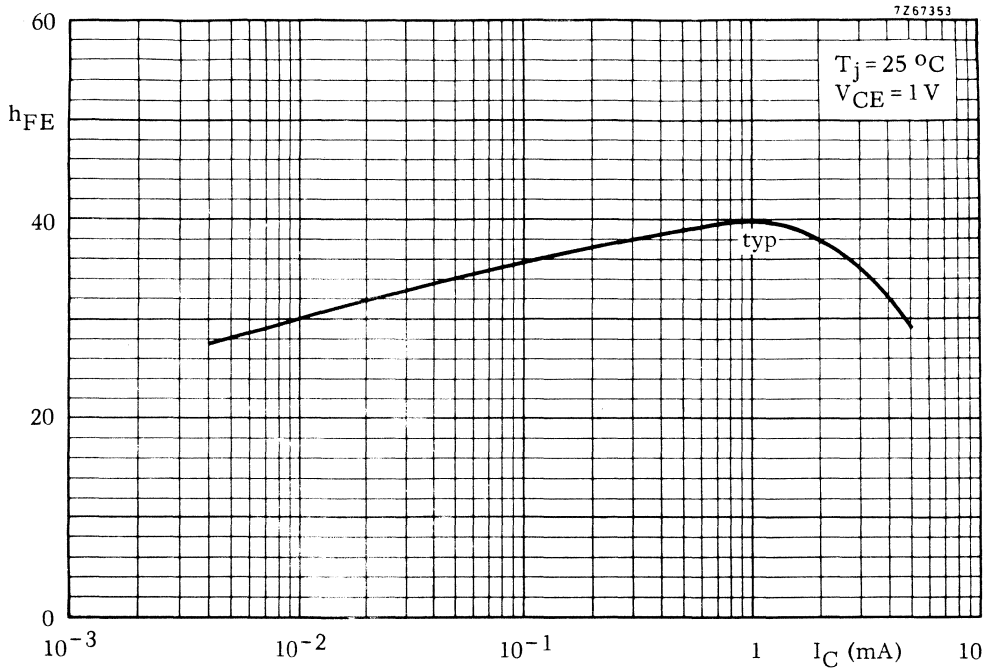

Fig. 3 $V_{CE} = 1\text{ V}$; $T_j = 25\text{ }^\circ\text{C}$; typical values.

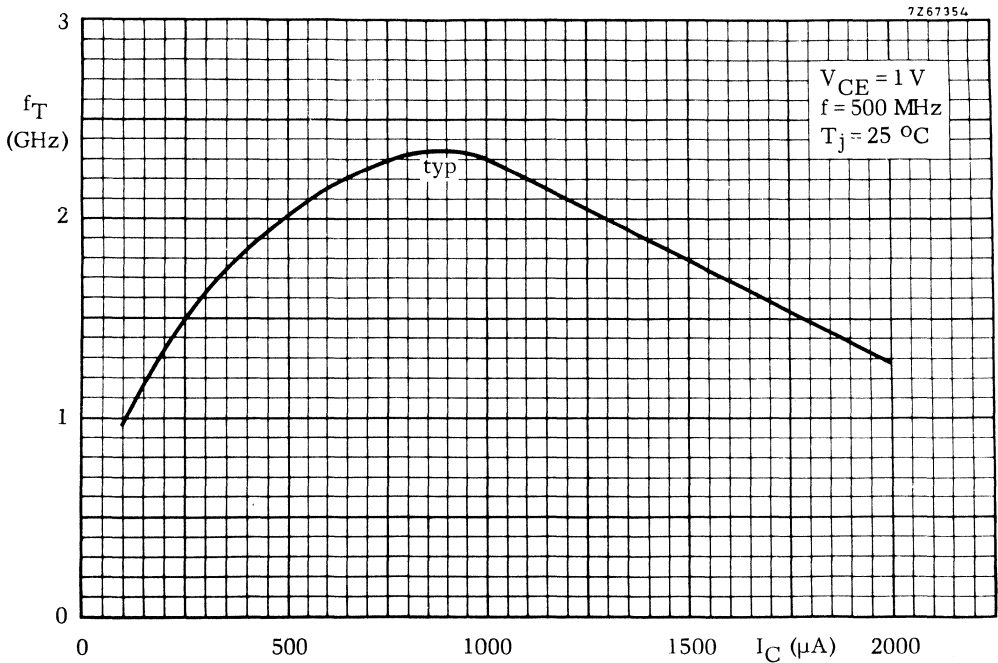

Fig. 4 $V_{CE} = 1\text{ V}$; $f = 500\text{ MHz}$; $T_j = 25\text{ }^\circ\text{C}$; typical values.

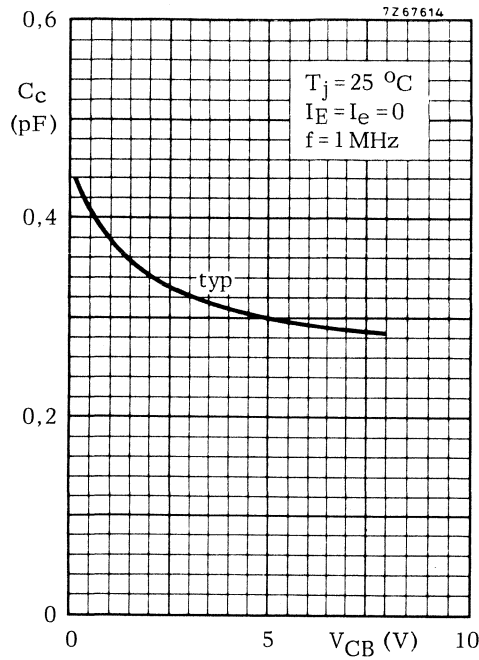

Fig. 5 $I_E = I_e = 0$; $f = 1\text{ MHz}$; $T_j = 25\text{ }^\circ\text{C}$; typical values.

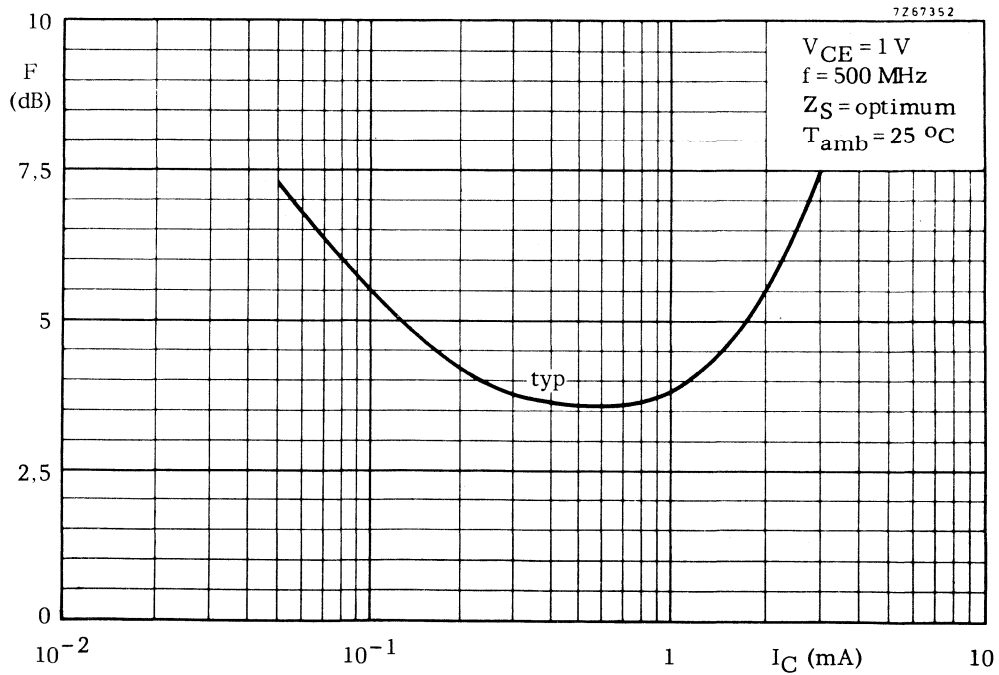

Fig. 6 $V_{CE} = 1\text{ V}$; $f = 500\text{ MHz}$; $Z_S = \text{opt.}$; $T_{\text{amb}} = 25\text{ }^\circ\text{C}$; typical values.

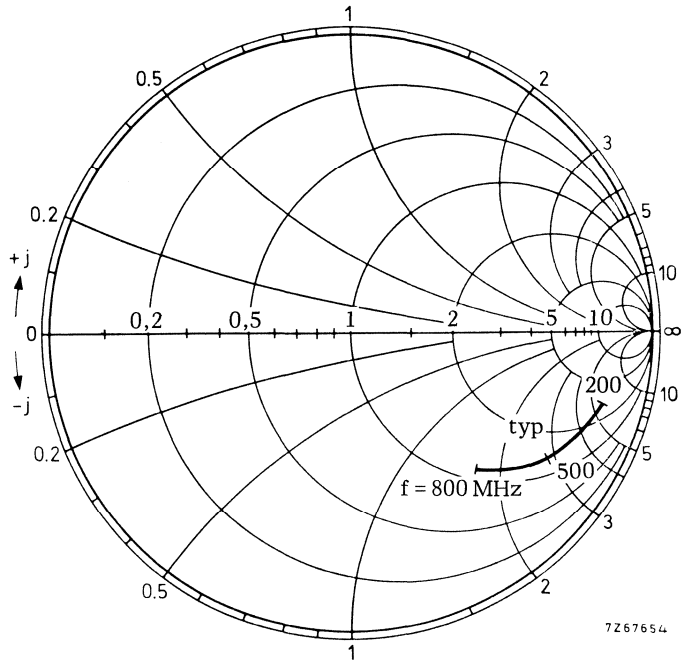

Fig. 7 $V_{CE} = 1\text{ V}$; $I_C = 1\text{ mA}$;
 $T_{amb} = 25\text{ }^\circ\text{C}$; typical values.

Input impedance derived from
 input reflection coefficient s_{ie}
 coordinates in ohm $\times 50$

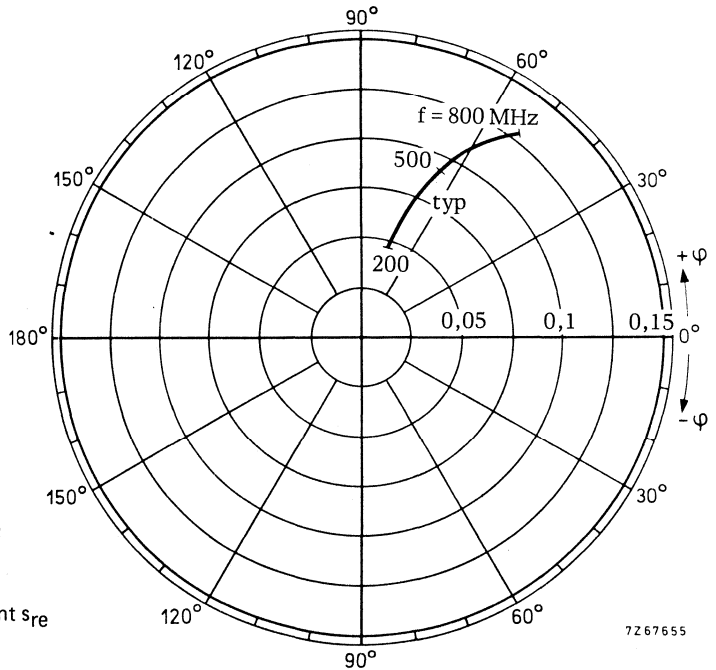

Fig. 8 $V_{CE} = 1\text{ V}$; $I_C = 1\text{ mA}$;
 $T_{amb} = 25\text{ }^\circ\text{C}$; typical values.

Reverse transmission coefficient s_{re}

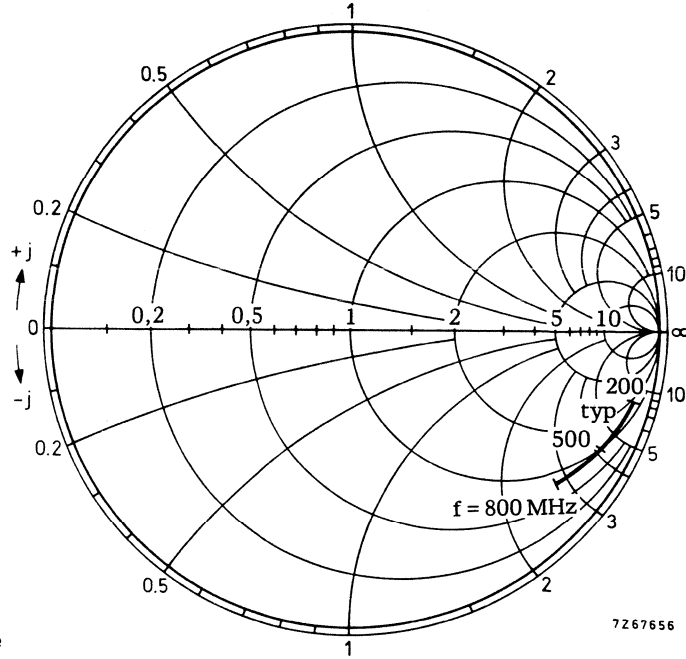

Fig. 9 $V_{CE} = 1\text{ V}$; $I_C = 1\text{ mA}$;
 $T_{amb} = 25\text{ }^\circ\text{C}$; typical values.

Output impedance derived from
 output reflection coefficient s_{oe}
 coordinates in $\text{ohm} \times 50$

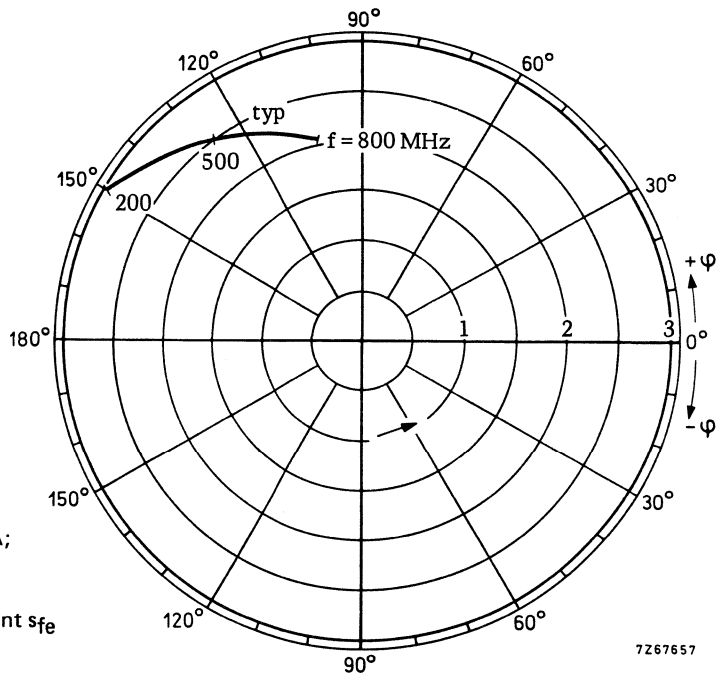

Fig. 10 $V_{CE} = 1\text{ V}$; $I_C = 1\text{ mA}$;
 $T_{amb} = 25\text{ }^\circ\text{C}$; typical values.

Forward transmission coefficient s_{fe}

N-CHANNEL SILICON FET

N-channel silicon epitaxial planar junction field-effect transistor in a microminiature plastic envelope. The transistor is intended for low level general purpose amplifiers in thick and thin-film circuits.

QUICK REFERENCE DATA

Drain-source voltage	$\pm V_{DS}$	max.	25 V
Gate-source voltage (open drain)	$-V_{GSO}$	max.	25 V
Total power dissipation up to $T_{amb} = 65\text{ }^{\circ}\text{C}$	P_{tot}	max.	250 mW
Drain current			
$V_{DS} = 10\text{ V}; V_{GS} = 0$	I_{DSS}	$>$	0,2 mA
		$<$	1,5 mA
Transfer admittance (common source)			
$I_D = 0,2\text{ mA}; V_{DS} = 10\text{ V}; f = 1\text{ kHz}$	$ y_{fs} $	$>$	0,5 mS
Equivalent noise voltage			
$V_{DS} = 10\text{ V}; I_D = 200\text{ }\mu\text{A}; B = 0,6\text{ to }100\text{ Hz}$	V_n	$<$	0,5 μV

MECHANICAL DATA

Fig. 1 SOT-23.

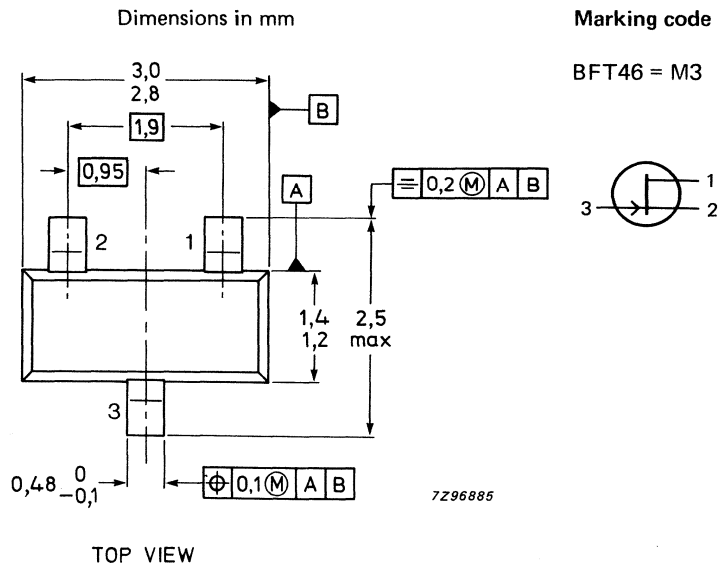
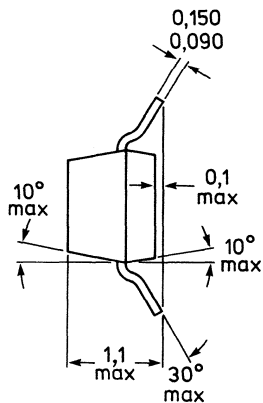

See also *Soldering recommendations*.

RATINGS

Limiting values in accordance with the Absolute Maximum System (IEC 134)

Drain-source voltage	$\pm V_{DS}$	max.	25 V
Drain-gate voltage (open source)	V_{DGO}	max.	25 V
Gate-source voltage (open drain)	$-V_{GSO}$	max.	25 V
Drain current	I_D	max.	10 mA
Gate current	I_G	max.	5 mA
Total power dissipation up to $T_{amb} = 65\text{ }^\circ\text{C}^{**}$	P_{tot}	max.	250 mW
Storage temperature range	T_{stg}		-65 to +175 $^\circ\text{C}$
Junction temperature	T_j	max.	175 $^\circ\text{C}$

THERMAL CHARACTERISTICS*

$$R_{th\ j-t} + R_{th\ t-s} + R_{th\ s-a} = \frac{T_j - T_{amb}}{P}$$

Thermal resistance

From junction to tab	$R_{th\ j-t}$	=	60 K/W
From tab to soldering points	$R_{th\ t-s}$	=	280 K/W
From soldering points to ambient**	$R_{th\ s-a}$	=	90 K/W

CHARACTERISTICS

$T_j = 25\text{ }^\circ\text{C}$ unless otherwise specified

Gate cut-off current $-V_{GS} = 10\text{ V}; V_{DS} = 0$	$-I_{GSS}$	<	0,2 nA
Drain current ** $V_{DS} = 10\text{ V}; V_{GS} = 0$	I_{DSS}	>	0,2 mA
		<	1,5 mA
Gate-source voltage $I_D = 50\text{ }\mu\text{A}; V_{DS} = 10\text{ V}$	$-V_{GS}$	>	0,1 V
		<	1,0 V
Gate-source cut-off voltage $I_D = 0,5\text{ nA}; V_{DS} = 10\text{ V}$	$-V_{(P)GS}$	<	1,2 V
y-parameters at $f = 1\text{ kHz}; V_{DS} = 10\text{ V}; V_{GS} = 0; T_{amb} = 25\text{ }^\circ\text{C}$			
Transfer admittance	$ y_{fs} $	>	1,0 mS
Output admittance	$ y_{os} $	<	10 μS
$V_{DS} = 10\text{ V}; I_D = 200\text{ }\mu\text{A};$			
Transfer admittance	$ y_{fs} $	>	0,5 mS
Output admittance	$ y_{os} $	<	5 μS

* See *Thermal characteristics*.

** Mounted on a ceramic substrate of 8 mm x 10 mm x 0,7 mm.

Input capacitance at $f = 1 \text{ MHz}$;

$V_{DS} = 10 \text{ V}$; $V_{GS} = 0$; $T_{amb} = 25 \text{ }^\circ\text{C}$

$C_{is} < 5 \text{ pF}$

Feedback capacitance at $f = 1 \text{ MHz}$;

$V_{DS} = 10 \text{ V}$; $V_{GS} = 0$; $T_{amb} = 25 \text{ }^\circ\text{C}$

$C_{rs} < 1,5 \text{ pF}$

Equivalent noise voltage

$V_{DS} = 10 \text{ V}$; $I_D = 200 \text{ } \mu\text{A}$; $T_{amb} = 25 \text{ }^\circ\text{C}$

$B = 0,6 \text{ to } 100 \text{ Hz}$

$V_n < 0,5 \text{ } \mu\text{V}$

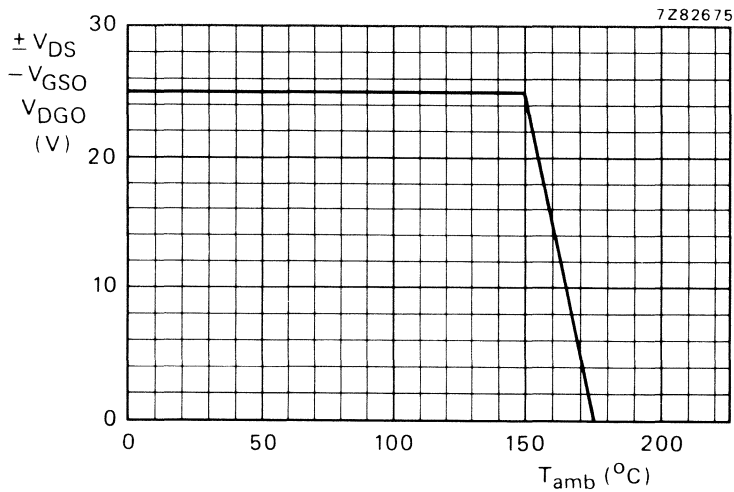

Fig. 2 Voltage derating curve.

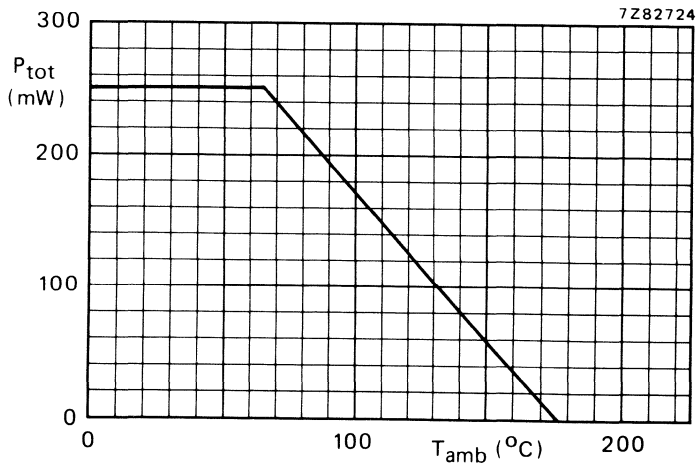

Fig. 3 Power derating curve.

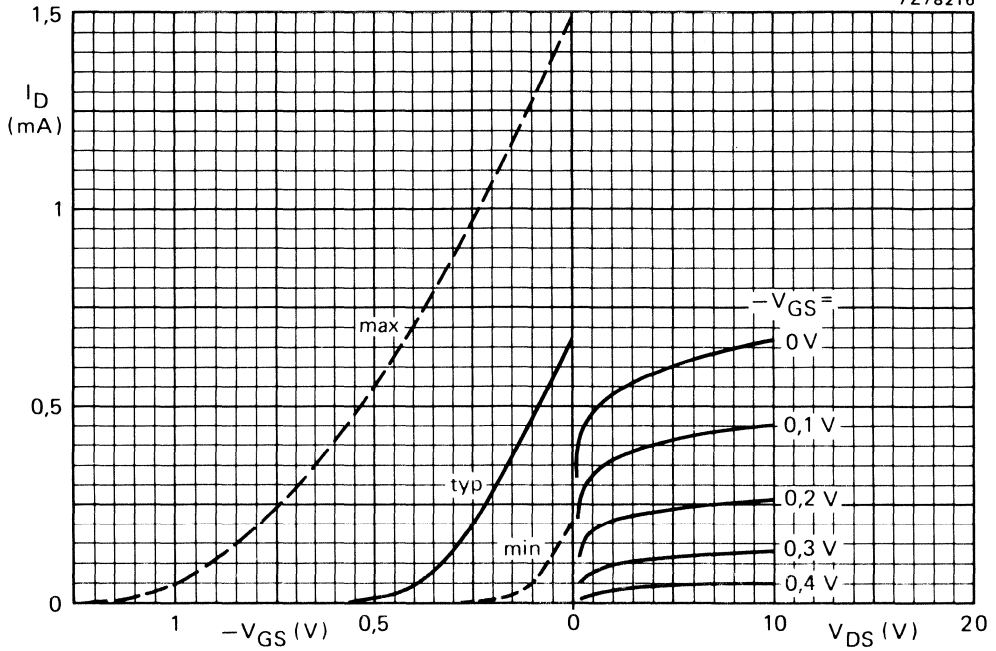

Fig. 4 Typical values. $V_{DS} = 10 \text{ V}$; $T_j = 25 \text{ }^\circ\text{C}$.

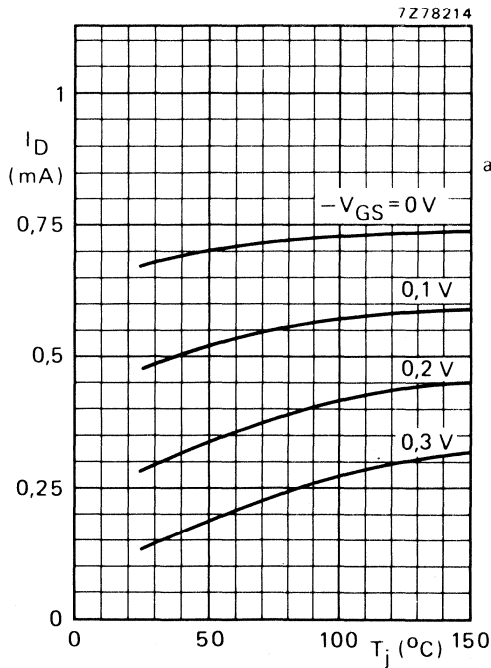

Fig. 5 Typical values. $V_{DS} = 10 \text{ V}$.

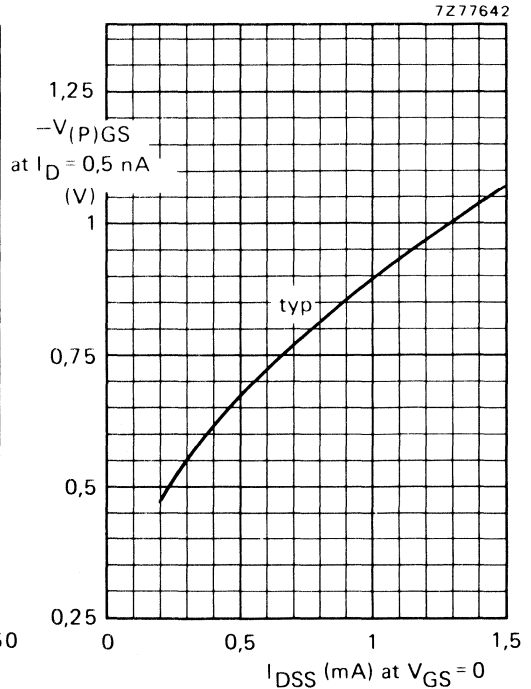

Fig. 6 Correlation between $-V_{(P)GS}$ and I_{DSS} . $V_{DS} = 10 \text{ V}$; $T_j = 25 \text{ }^\circ\text{C}$.

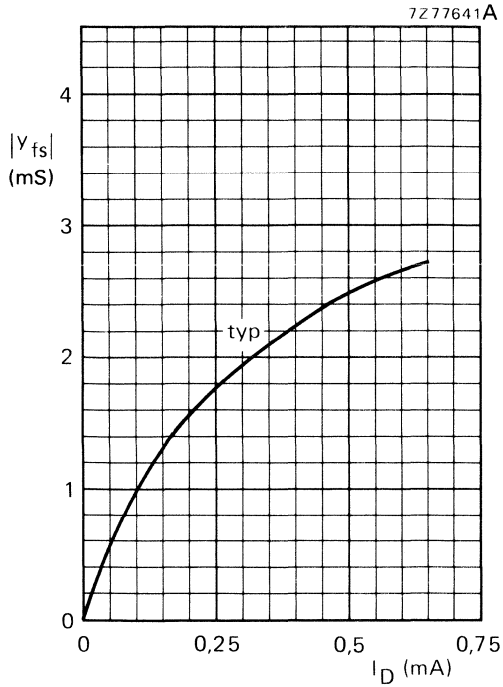

Fig. 7.

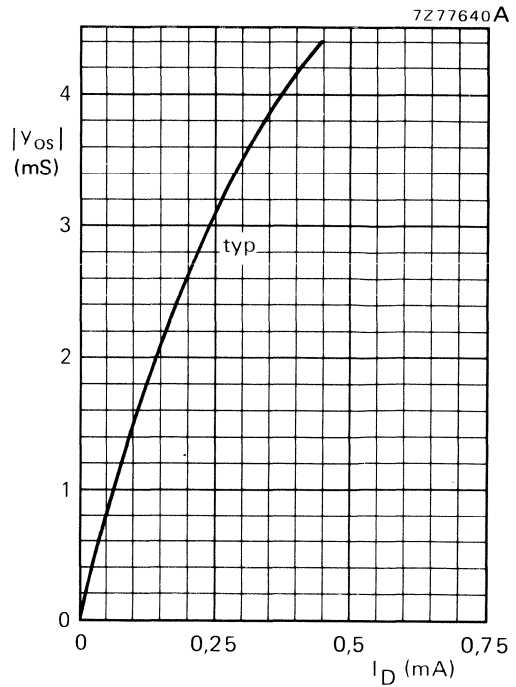

Fig. 8.

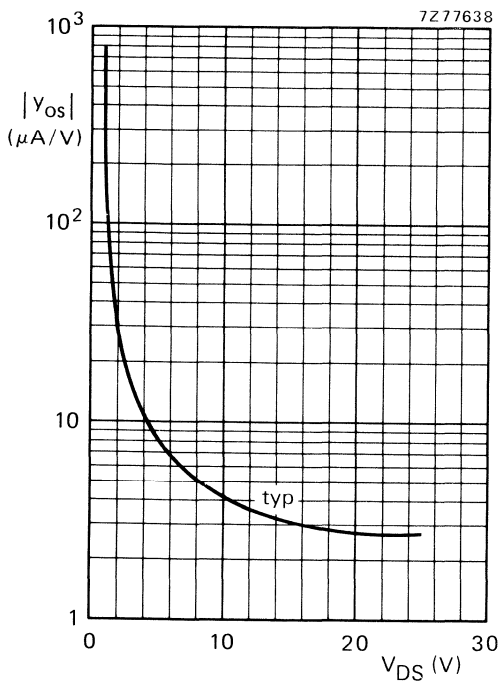

Fig. 9.

Fig. 7 $|y_{fs}|$ versus I_D .
 $V_{DS} = 10$ V; $f = 1$ kHz; $T_{amb} = 25$ °C.

Fig. 8 $|y_{os}|$ versus I_D .
 $V_{DS} = 10$ V; $f = 1$ kHz; $T_{amb} = 25$ °C.

Fig. 9 $|y_{os}|$ versus V_{DS} .
 $I_D = 0,4$ mA; $f = 1$ kHz; $T_{amb} = 25$ °C.

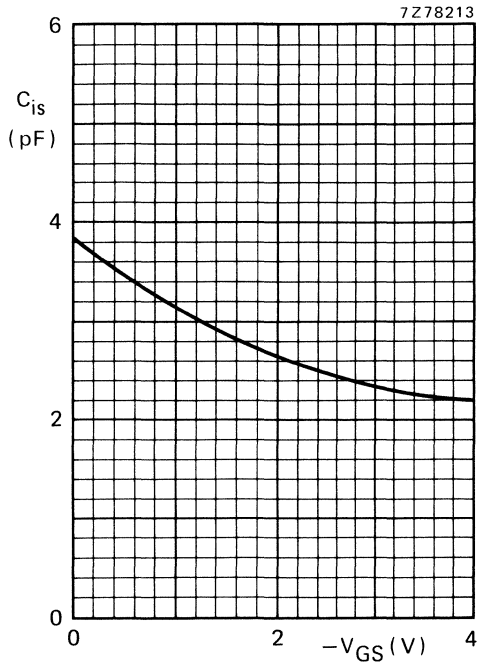

Fig. 10.

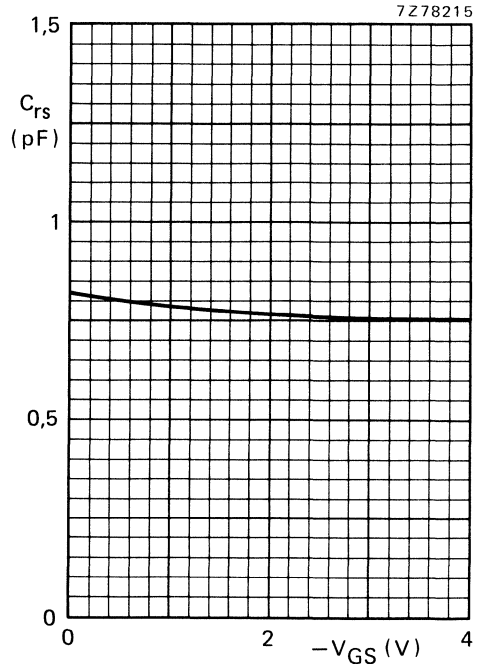

Fig. 11.

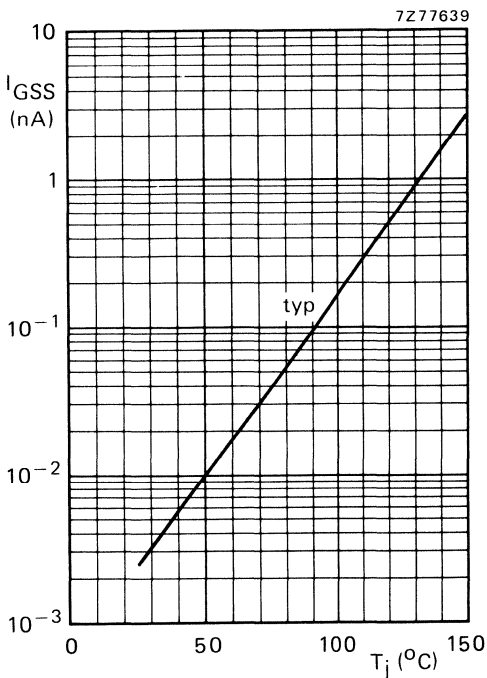
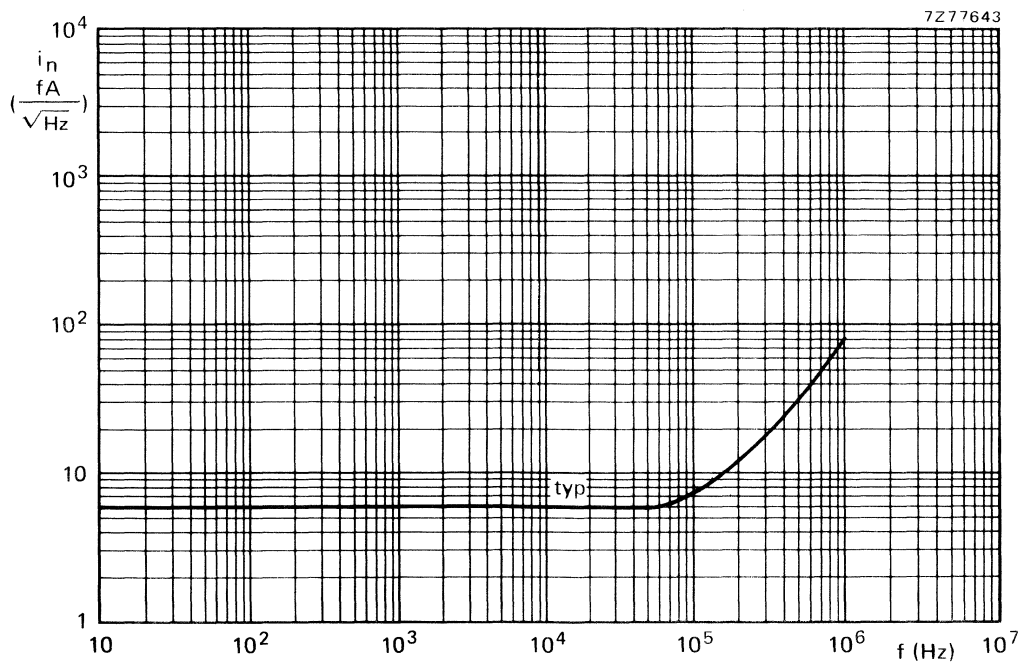
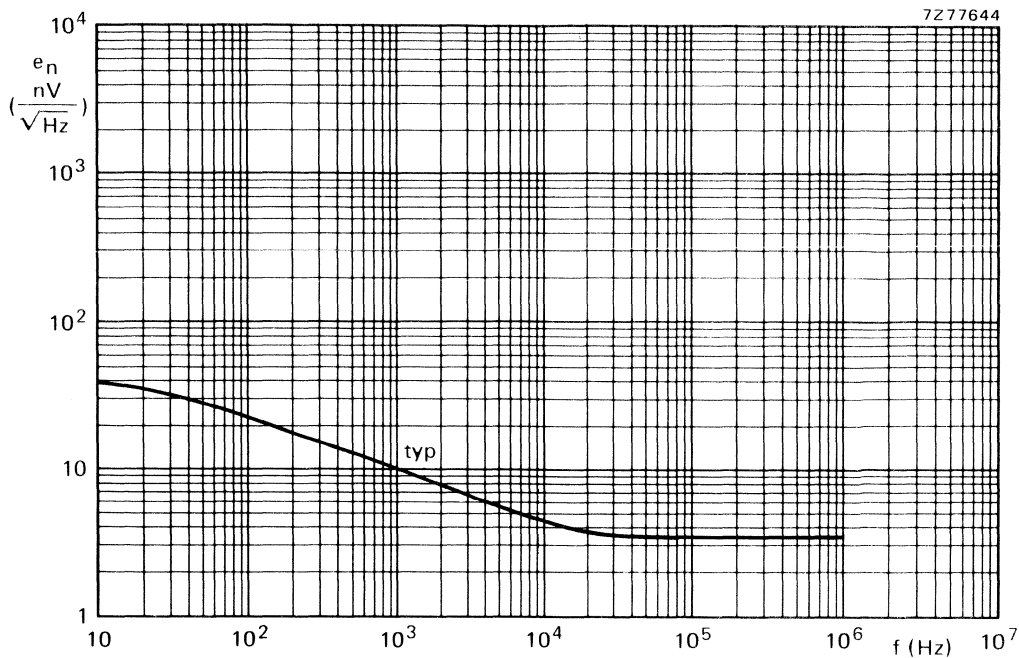

Fig. 12.

Fig.10 Typical values.
 $V_{DS} = 10$ V, $T_{amb} = 25$ °C.

Fig.11 Typical values.
 $V_{DS} = 10$ V, $T_{amb} = 25$ °C.

Fig.12 I_{GSS} versus T_j .
 $-V_{GSS} = 10$ V; $V_{DS} = 0$.



SILICON PLANAR EPITAXIAL TRANSISTORS

P-N-P transistor in a microminiature plastic envelope. It is primarily intended for use in u.h.f. and microwave amplifiers in thick and thin-film circuits, such as in aerial amplifiers, radar systems, oscilloscopes, spectrum analysers, etc.

The transistor features low intermodulation distortion and high power gain; thanks to its very high transition frequency, it also has excellent wideband properties and low noise up to high frequencies.

N-P-N complements are BFR92 and BFR92A.

QUICK REFERENCE DATA

Collector-base voltage (open emitter)	$-V_{CBO}$	max.	20 V
Collector-emitter voltage (open base)	$-V_{CEO}$	max.	15 V
Collector current (d.c.)	$-I_C$	max.	25 mA
Total power dissipation up to $T_{amb} = 60\text{ }^{\circ}\text{C}$	P_{tot}	max.	200 mW
Junction temperature	T_j	max.	150 $^{\circ}\text{C}$
Transition frequency at $f = 500\text{ MHz}$ $-I_C = 14\text{ mA}; -V_{CE} = 10\text{ V}$	f_T	typ.	5 GHz
Feedback capacitance at $f = 1\text{ MHz}$ $-I_C = 2\text{ mA}; -V_{CE} = 10\text{ V}; T_{amb} = 25\text{ }^{\circ}\text{C}$	C_{re}	typ.	0,7 pF
Noise figure at optimum source impedance $-I_C = 2\text{ mA}; -V_{CE} = 10\text{ V}; f = 500\text{ MHz}; T_{amb} = 25\text{ }^{\circ}\text{C}$	F	typ.	2,7 dB
Max. unilateral power gain $-I_C = 14\text{ mA}; -V_{CE} = 10\text{ V}; f = 500\text{ MHz}; T_{amb} = 25\text{ }^{\circ}\text{C}$	G_{UM}	typ.	18 dB
Intermodulation distortion at $T_{amb} = 25\text{ }^{\circ}\text{C}$ $-I_C = 14\text{ mA}; -V_{CE} = 10\text{ V}; R_L = 75\text{ }\Omega; V_o = 150\text{ mV}$ $f_{(p+q-r)} = 493,25\text{ MHz}$	d_{im}	typ.	-60 dB

MECHANICAL DATA

(See next page).

See also *Soldering recommendations*.

CHARACTERISTICS

$T_j = 25\text{ }^\circ\text{C}$ unless otherwise specified

Collector cut-off current

$$I_E = 0; -V_{CB} = 10\text{ V}$$

$$-I_{CBO} \quad \text{max.} \quad 50\text{ nA}$$

D.C. current gain

$$-I_C = 14\text{ mA}; -V_{CE} = 10\text{ V}$$

$$h_{FE} \quad \begin{array}{l} \text{min.} \quad 20 \\ \text{typ.} \quad 50 \end{array}$$

Transition frequency at $f = 500\text{ MHz}$

$$-I_C = 14\text{ mA}; -V_{CE} = 10\text{ V}$$

$$f_T \quad \text{typ.} \quad 5,0\text{ GHz}$$

Collector capacitance at $f = 1\text{ MHz}$

$$I_E = I_e = 0; -V_{CB} = 10\text{ V}$$

$$C_c \quad \text{typ.} \quad 0,75\text{ pF}$$

Emitter capacitance at $f = 1\text{ MHz}$

$$I_C = I_c = 0; -V_{EB} = 0,5\text{ V}$$

$$C_e \quad \text{typ.} \quad 0,8\text{ pF}$$

$T_{amb} = 25\text{ }^\circ\text{C}$

Feedback capacitance at $f = 1\text{ MHz}$

$$-I_C = 2\text{ mA}; -V_{CE} = 10\text{ V}$$

$$C_{re} \quad \text{typ.} \quad 0,7\text{ pF}$$

Noise figure at optimum source impedance *

$$-I_C = 2\text{ mA}; -V_{CE} = 10\text{ V}; f = 500\text{ MHz}$$

$$F \quad \text{typ.} \quad 2,7\text{ dB}$$

Max. unilateral power gain (s_{re} assumed to be zero)

$$G_{UM} = 10 \log \frac{|s_{fe}|^2}{(1 - |s_{ie}|^2)(1 - |s_{oe}|^2)}$$

$$-I_C = 14\text{ mA}; -V_{CE} = 10\text{ V}; f = 500\text{ MHz}$$

$$G_{UM} \quad \text{typ.} \quad 18,0\text{ dB}$$

Output voltage at $d_{im} = -60\text{ dB}$ (see Fig. 2)

(DIN 45004B, par. 6.3.: 3-tone)

$$-I_C = 14\text{ mA}; -V_{CE} = 10\text{ V}; R_L = 75\text{ }\Omega$$

$$V_p = V_o \text{ at } d_{im} = -60\text{ dB}; f_p = 495,25\text{ MHz}$$

$$V_q = V_o -6\text{ dB} \quad ; f_q = 503,25\text{ MHz}$$

$$V_r = V_o -6\text{ dB} \quad ; f_r = 505,25\text{ MHz}$$

$$\text{measured at } f_{(p+q-r)} = 493,25\text{ MHz}$$

$$V_o \quad \text{typ.} \quad 150\text{ mV}$$

* Crystal mounted in SOT-37 envelope.

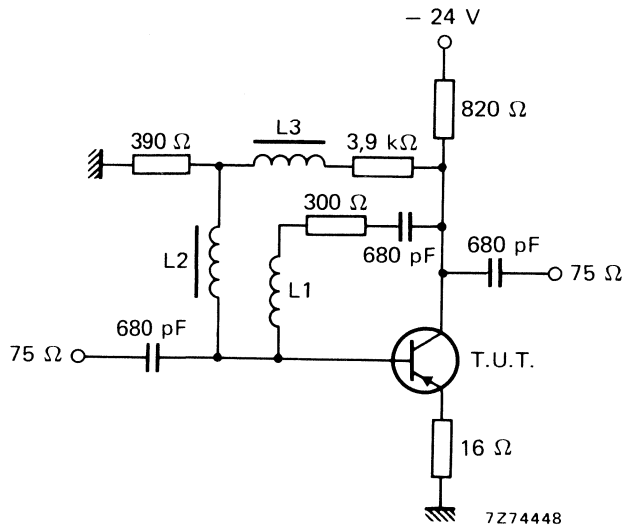

Fig. 2 Intermodulation test circuit.

L1 = 4 turns Cu wire (0,35 mm); winding pitch 1 mm; int. dia. 4 mm.
 L2 = L3 = 5 μ H (catalogue number: 3122 108 20150).

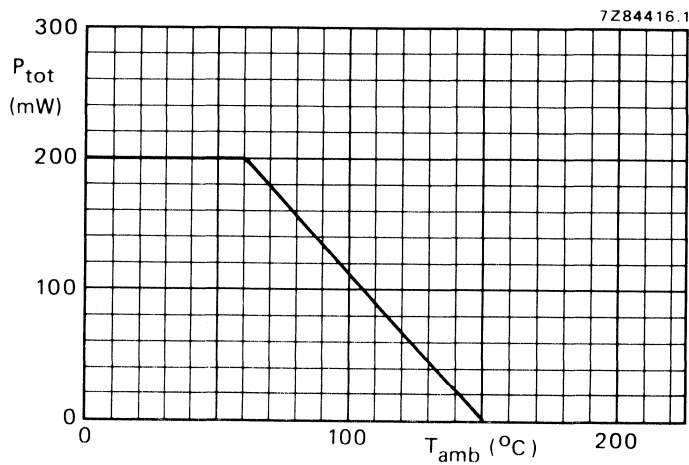

Fig. 3 Power derating curve.

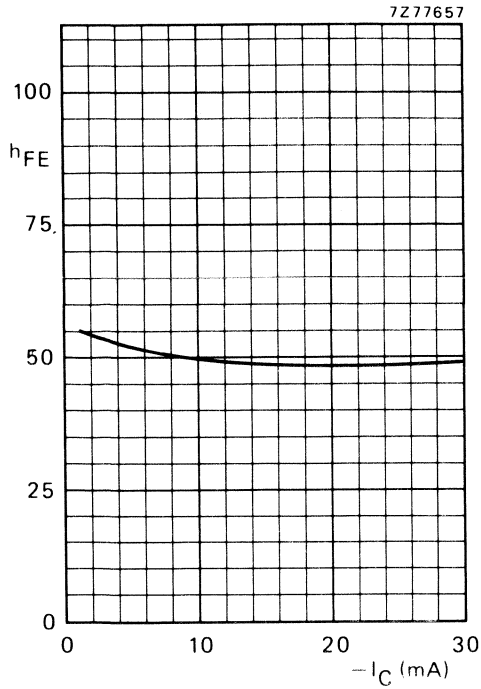

Fig. 4 $-V_{CE} = 10$ V; $T_j = 25$ °C; typical values.

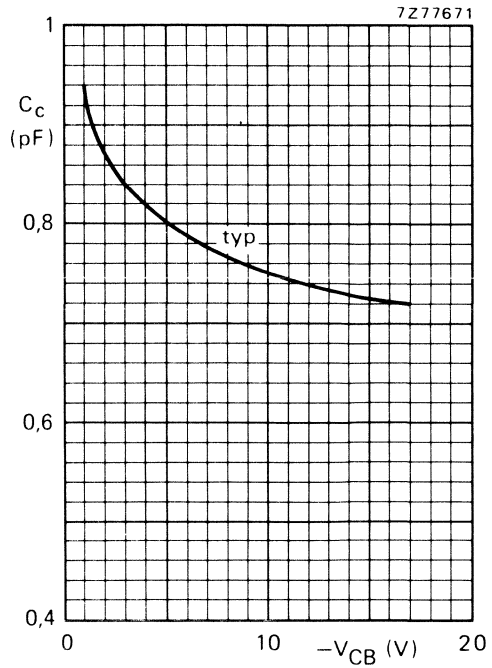

Fig. 5 $I_E = I_e = 0$; $T_j = 25$ °C; $f = 1$ MHz; typical values.

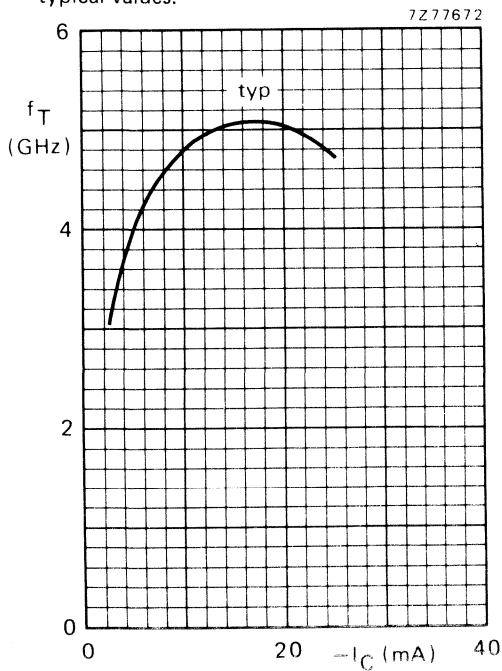

Fig. 6 $-V_{CE} = 10$ V; $f = 500$ MHz; $T_j = 25$ °C; typical values.

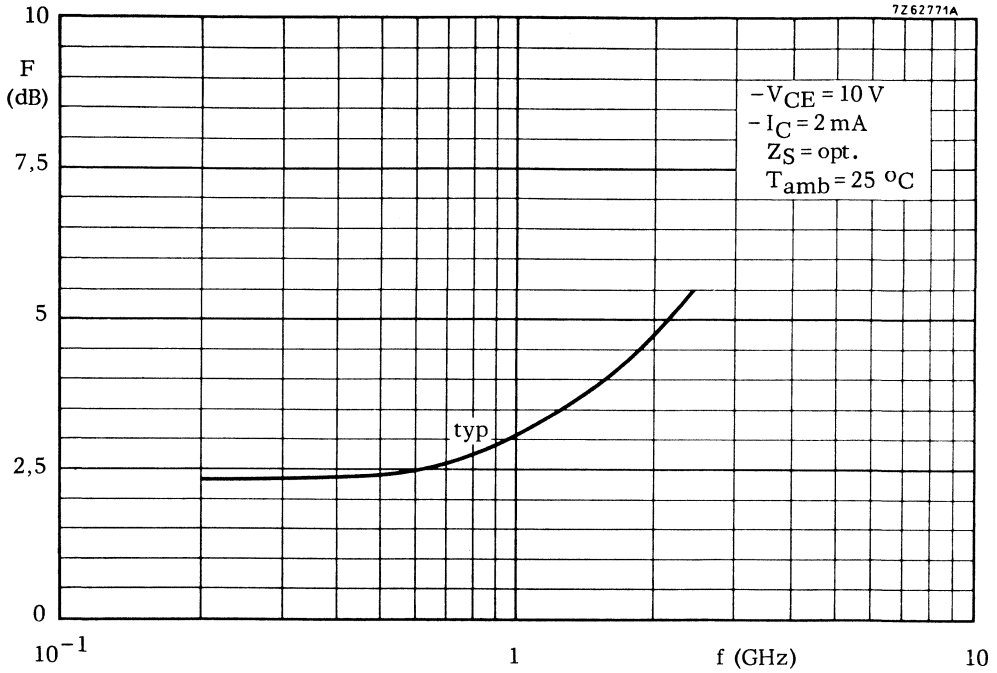

Fig. 7 $-V_{CE} = 10\text{ V}$; $-I_C = 2\text{ mA}$; $Z_S = \text{opt.}$; $T_{\text{amb}} = 25\text{ }^\circ\text{C}$; typical values.

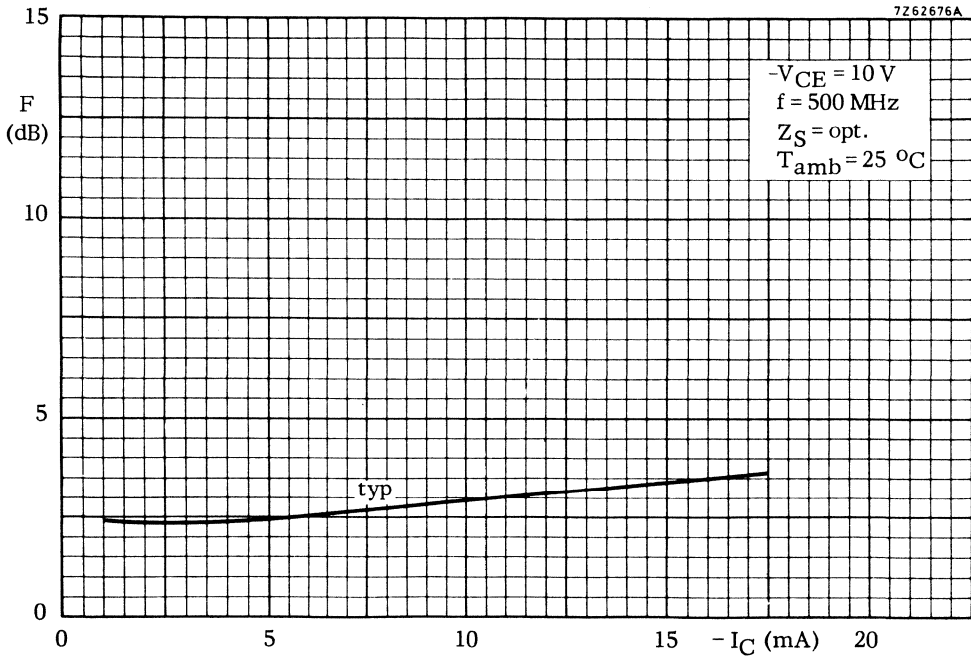

Fig. 8 $-V_{CE} = 10\text{ V}$; $f = 500\text{ MHz}$; $Z_S = \text{opt.}$; $T_{\text{amb}} = 25\text{ }^\circ\text{C}$; typical values.

P-N-P 1 GHz WIDEBAND TRANSISTOR

P-N-P transistor in a plastic SOT-23 envelope. It is primarily intended for use in u.h.f. and microwave amplifiers in thick and thin-film circuits, such as in aerial amplifiers, radar systems, oscilloscopes, spectrum analyses, etc.

The transistor features low intermodulation distortion and high power gain; thanks to its very high transition frequency, it also has excellent wideband properties and low noise up to high frequencies.

N-P-N complements are BFR93 and BFR93A.

QUICK REFERENCE DATA

Collector-base voltage (open emitter)	$-V_{CBO}$	max.	15 V
Collector-emitter voltage (open base)	$-V_{CEO}$	max.	12 V
Collector current (d.c.)	$-I_C$	max.	35 mA
Total power dissipation up to $T_{amb} = 60\text{ }^{\circ}\text{C}$	P_{tot}	max.	200 mW
Junction temperature	T_j	max.	150 $^{\circ}\text{C}$
Transition frequency at $f = 500\text{ MHz}$ $-I_C = 30\text{ mA}; -V_{CE} = 5\text{ V}$	f_T	typ.	5,0 GHz
Feedback capacitance at $f = 1\text{ MHz}$ $-I_C = 2\text{ mA}; -V_{CE} = 5\text{ V}$	C_{re}	typ.	1,0 pF
Noise figure at optimum source impedance $-I_C = 2\text{ mA}; -V_{CE} = 5\text{ V}; f = 500\text{ MHz}$	F	typ.	2,4 dB
Max. unilateral power gain $-I_C = 30\text{ mA}; -V_{CE} = 5\text{ V}; f = 500\text{ MHz}$	GUM	typ.	16,5 dB
Output voltage at $d_{im} = -60\text{ dB}$ $-I_C = 30\text{ mA}; -V_{CE} = 5\text{ V}; R_L = 75\text{ }\Omega$ $f_{(p+q-r)} = 493,25\text{ MHz}$	V_o	typ.	300 mV

MECHANICAL DATA

Dimensions in mm

Marking code

Fig. 1 SOT-23.

BFT93 = X1

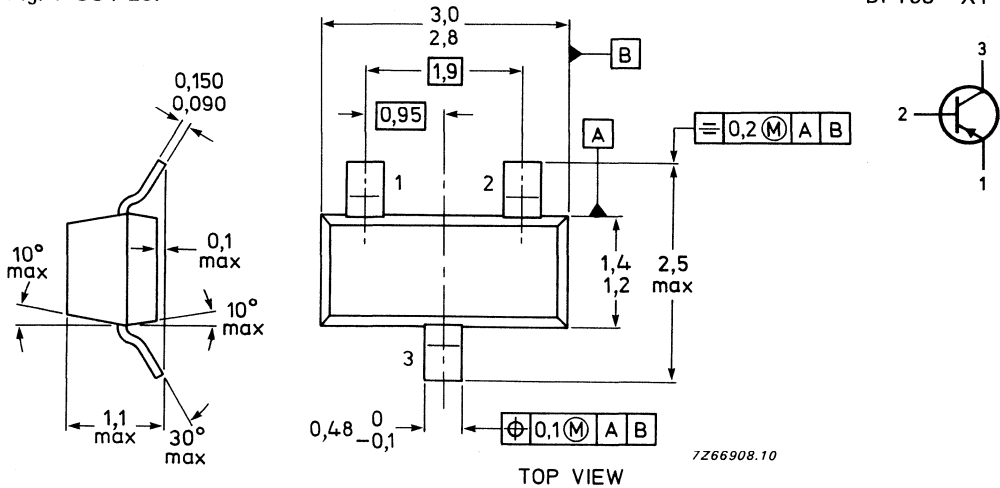

If required, the R-version (reverse pinning) is available on request.

RATINGS

Limiting values in accordance with the Absolute Maximum System (IEC 134)

Collector-base voltage (open emitter)	$-V_{CBO}$	max.	15 V
Collector-emitter voltage (open base)	$-V_{CEO}$	max.	12 V
Emitter-base voltage (open collector)	$-V_{EBO}$	max.	2 V
Collector current (d.c.)	$-I_C$	max.	35 mA
Collector current (peak value; $f > 1$ MHz)	$-I_{CM}$	max.	50 mA
Total power dissipation up to $T_{amb} = 60$ °C **	P_{tot}	max.	200 mW
Storage temperature	T_{stg}		-65 to + 150 °C
Junction temperature	T_j	max.	150 °C

THERMAL CHARACTERISTICS *

$$T_j = P \times (R_{th\ j-t} + R_{th\ t-s} + R_{th\ s-a}) + T_{amb}$$

Thermal resistance

From junction to tab	$R_{th\ j-t}$	=	60 K/W
From tab to soldering points	$R_{th\ t-s}$	=	280 K/W
From soldering points to ambient **	$R_{th\ s-a}$	=	90 K/W

* See *Thermal characteristics*.

** Mounted on a ceramic substrate of 8 mm x 10 mm x 0,7 mm.

CHARACTERISTICS

$T_j = 25\text{ }^\circ\text{C}$ unless otherwise specified

Collector cut-off current

$$I_E = 0; -V_{CB} = 5\text{ V}$$

$$-I_{CBO} \quad \text{max.} \quad 50\text{ nA}$$

D.C. current gain

$$-I_C = 30\text{ mA}; -V_{CE} = 5\text{ V}$$

$$h_{FE} \quad \begin{array}{l} \text{min.} \quad 20 \\ \text{typ.} \quad 50 \end{array}$$

Transition frequency at $f = 500\text{ MHz}$

$$-I_C = 30\text{ mA}; -V_{CE} = 5\text{ V}$$

$$f_T \quad \text{typ.} \quad 5,0\text{ GHz}$$

Collector capacitance at $f = 1\text{ MHz}$

$$I_E = I_e = 0; -V_{CB} = 10\text{ V}$$

$$C_c \quad \text{typ.} \quad 0,95\text{ pF}$$

Emitter capacitance at $f = 1\text{ MHz}$

$$I_C = I_c = 0; -V_{EB} = 0,5\text{ V}$$

$$C_e \quad \text{typ.} \quad 1,8\text{ pF}$$

$T_{amb} = 25\text{ }^\circ\text{C}$

Feedback capacitance at $f = 1\text{ MHz}$

$$-I_C = 2\text{ mA}; -V_{CE} = 5\text{ V}$$

$$C_{re} \quad \text{typ.} \quad 1,0\text{ pF}$$

Noise figure at optimum source impedance *

$$-I_C = 2\text{ mA}; -V_{CE} = 5\text{ V}; f = 500\text{ MHz}$$

$$F \quad \text{typ.} \quad 2,4\text{ dB}$$

Max. unilateral power gain (s_{re} assumed to be zero)

$$G_{UM} = 10 \log \frac{|s_{fe}|^2}{(1 - |s_{ie}|^2)(1 - |s_{oe}|^2)}$$

$$-I_C = 30\text{ mA}; -V_{CE} = 5\text{ V}; f = 500\text{ MHz}$$

$$G_{UM} \quad \text{typ.} \quad 16,5\text{ dB}$$

Output voltage at $d_{im} = -60\text{ dB}$ (see Fig. 2)

$$-I_C = 30\text{ mA}; -V_{CE} = 5\text{ V}; R_L = 75\text{ }\Omega$$

$$V_p = V_o \text{ at } d_{im} = -60\text{ dB}; f_p = 495,25\text{ MHz}$$

$$V_q = V_o -6\text{ dB}; f_q = 503,25\text{ MHz}$$

$$V_r = V_o -6\text{ dB}; f_r = 505,25\text{ MHz}$$

$$\text{measured at } f(p + q - r) = 443,25\text{ MHz}$$

$$V_o \quad \text{typ.} \quad 300\text{ mV}$$

* Crystal mounted in SOT-37 envelope.

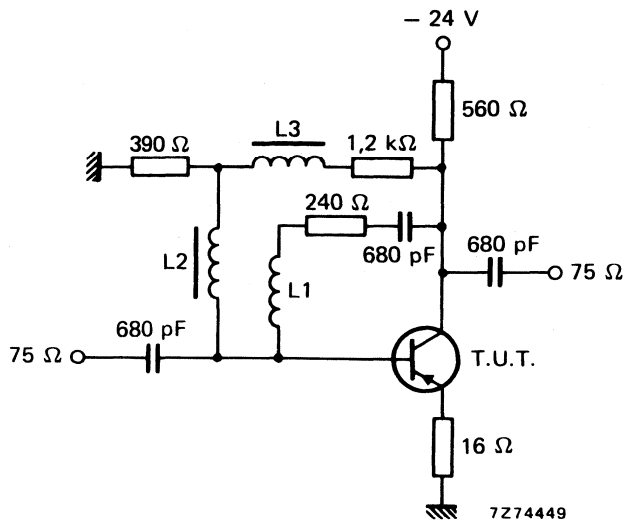

Fig. 2 Intermodulation test circuit.

L1 = 4 turns Cu wire (0,35); winding pitch 1 mm; int. dia. 4 mm.
 L2 and L3 = 5 μH (catalogue number: 3122 108 20150).

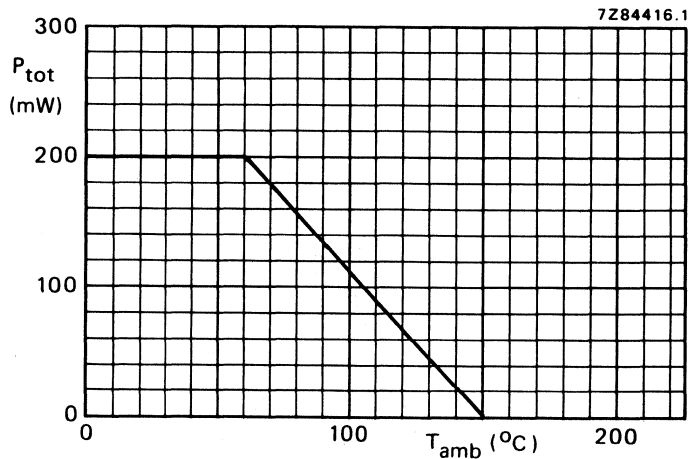

Fig. 3 Power derating curve.

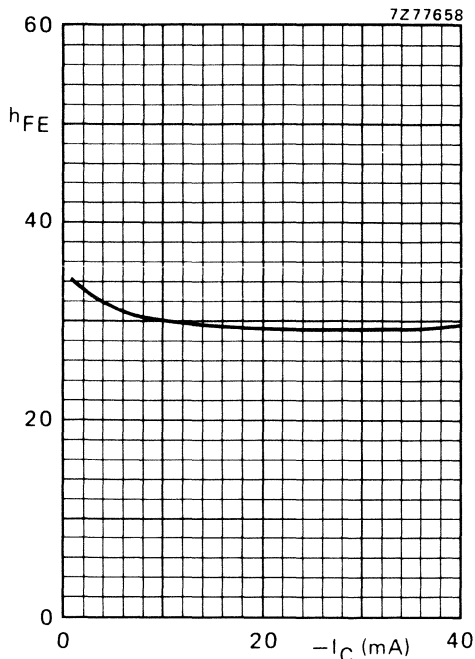

Fig. 4 $-V_{CE} = 5$ V; $T_j = 25$ °C; typical values.

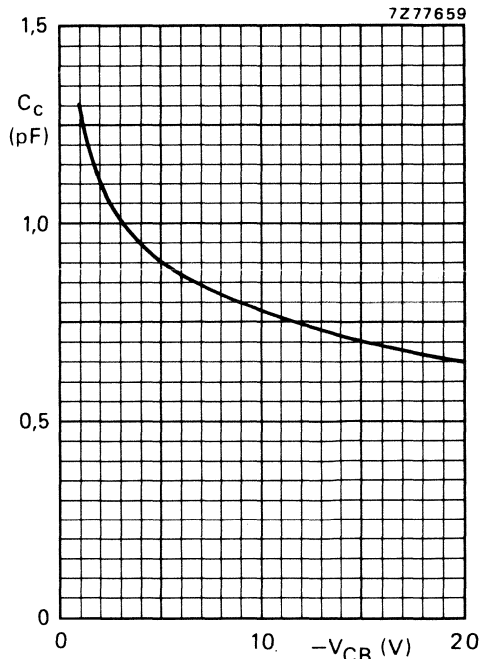

Fig. 5 $I_E = I_e = 0$; $T_j = 25$ °C; $f = 1$ MHz; typical values.

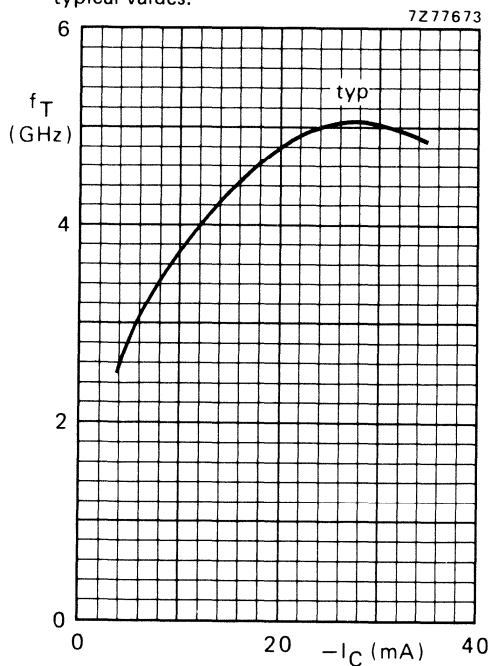

Fig. 6 $-V_{CE} = 5$ V; $T_j = 25$ °C; $f = 500$ MHz; typical values.

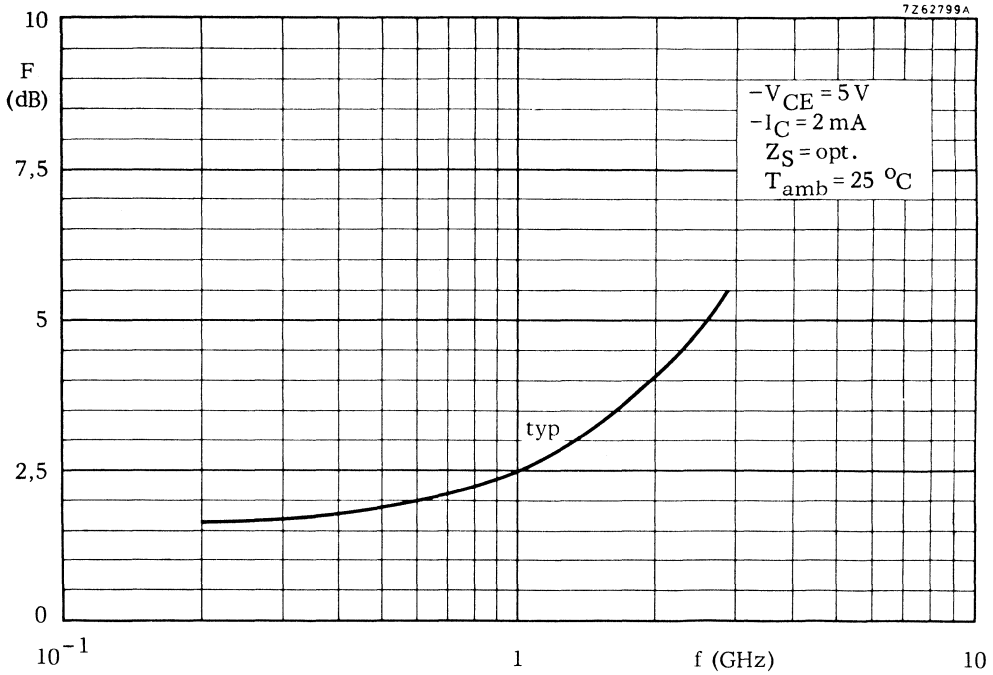

Fig. 7 $-V_{CE} = 5\text{ V}$; $-I_C = 2\text{ mA}$; $Z_S = \text{opt.}$; $T_{\text{amb}} = 25\text{ }^\circ\text{C}$; typical values.

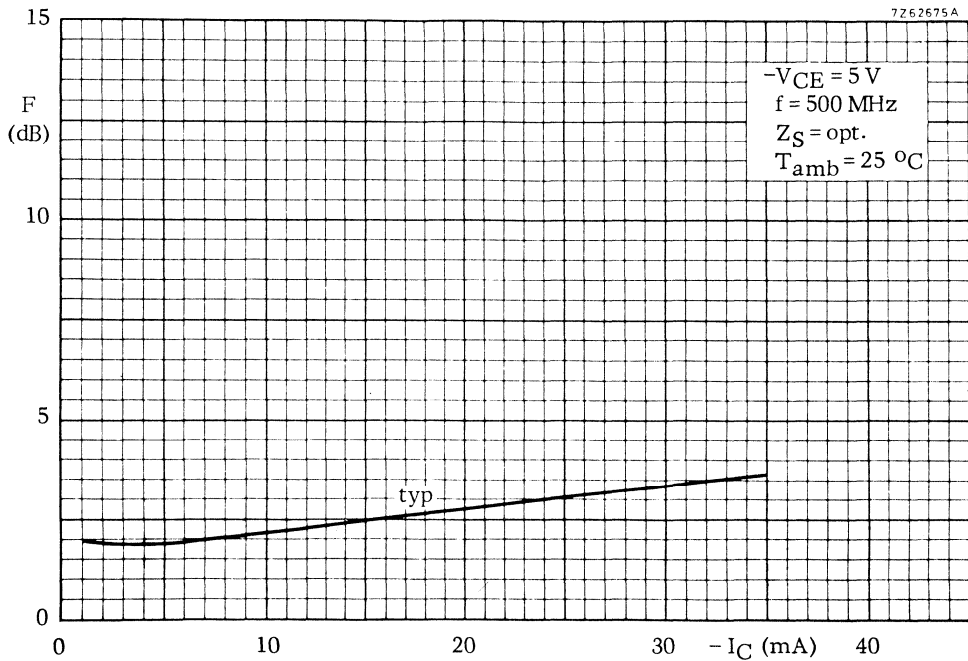

Fig. 8 $-V_{CE} = 5\text{ V}$; $f = 500\text{ MHz}$; $Z_S = \text{opt.}$; $T_{\text{amb}} = 25\text{ }^\circ\text{C}$; typical values.

PROGRAMMABLE UNIJUNCTION TRANSISTOR

Planar p-n-p-n trigger device in a microminiature plastic envelope intended for applications in thick and thin-film circuits. It is intended for use in switching applications such as motor control, oscillators, relay replacement, timers, pulse shaper, trigger device etc.

QUICK REFERENCE DATA

Gate-anode voltage	V_{GA}	max.	70 V
Anode current (d.c.) up to $T_{amb} = 25\text{ }^{\circ}\text{C}$	I_A	max.	175 mA
Junction temperature	T_j	max.	150 $^{\circ}\text{C}$
Peak point current $V_S = 10\text{ V}; R_G = 10\text{ k}\Omega$	I_P	<	5 μA
Valley point current $V_S = 10\text{ V}; R_G = 10\text{ k}\Omega$	I_V	>	30 μA

MECHANICAL DATA

Fig. 1 SOT-23.

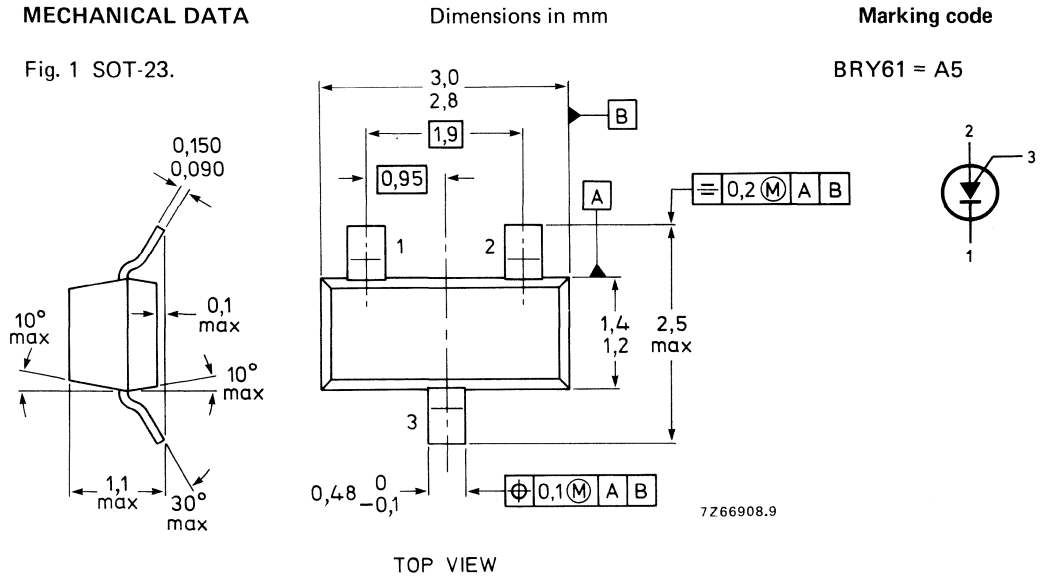

See also *Soldering Recommendations*.

RATINGS

Limiting values in accordance with the Absolute Maximum System (IEC 134)

Gate-anode voltage	V_{GA}	max.	70 V
Anode current (d.c.) up to $T_{amb} = 25\text{ }^{\circ}\text{C}$	I_A	max.	175 mA
Repetitive peak anode current $t = 10\text{ }\mu\text{s}; \delta = 0,01$	I_{ARM}	max.	2,5 A
Non-repetitive peak anode current $t = 10\text{ }\mu\text{s}; T_j = 150\text{ }^{\circ}\text{C}$	I_{ASM}	max.	3 A
Rate of rise of anode current up to $I_A = 2,5\text{ A}$	$\frac{dI_A}{dt}$	max.	20 A/ μs
Storage temperature	T_{stg}		-65 to +150 $^{\circ}\text{C}$
Junction temperature	T_j	max.	150 $^{\circ}\text{C}$
Total power dissipation up to $T_{amb} = 25\text{ }^{\circ}\text{C}^{**}$	P_{tot}	max.	275 mW

THERMAL CHARACTERISTICS*

$$T_j = P \times (R_{th\ j-t} + R_{th\ t-s} + R_{th\ s-a}) + T_{amb}$$

Thermal resistance

From junction to tab	$R_{th\ j-t}$	=	60 K/W
From tab to soldering points	$R_{th\ t-s}$	=	280 K/W
From soldering points to ambient**	$R_{th\ s-a}$	=	90 K/W

CHARACTERISTICS

$T_{amb} = 25\text{ }^{\circ}\text{C}$ unless otherwise specified

Peak point current (see Figs 2, 3 and 4)

$$V_S = 10\text{ V}; R_G = 10\text{ k}\Omega$$

$$V_S = 10\text{ V}; R_G = 1\text{ M}\Omega$$

I_p	<	5 μA
I_P	<	1 μA

Valley point current (see also Figs 2, 3 and 4)

$$V_S = 10\text{ V}; R_G = 10\text{ k}\Omega$$

$$V_S = 10\text{ V}; R_G = 1\text{ M}\Omega$$

I_V	>	30 μA
I_V	<	50 μA

Offset voltage (see Fig. 12)

$$I_A = 0 \text{ (for } V_P \text{ see Fig. 2; for } V_S \text{ see Fig. 4)}$$

$$V_{offset} = V_P - V_S \text{ V}$$

* See *Thermal characteristics*.

** Mounted on a ceramic substrate of 8 mm x 10 mm x 0,7 mm.

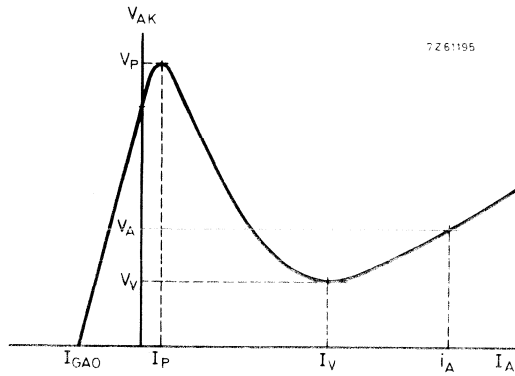

Fig. 2 See also Fig. 11.

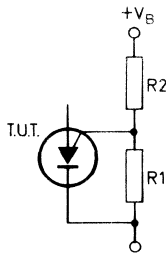

Fig. 3 BRY61 with "program" resistors R1 and R2.

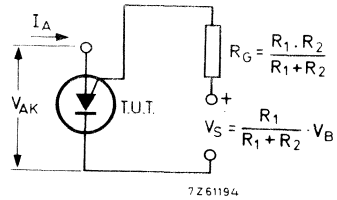

Fig. 4 Equivalent test circuit for characteristics testing.

Gate-anode leakage current (Fig. 5a)

$$I_K = 0; V_{GA} = 70 \text{ V}$$

$$I_{GAO} < 10 \text{ nA}$$

Gate-cathode leakage current (Fig. 5b)

$$V_{AK} = 0; V_{GK} = 70 \text{ V}$$

$$I_{GKS} < 100 \text{ nA}$$

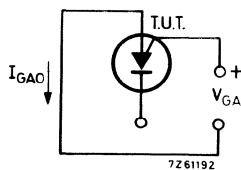

Fig. 5a.

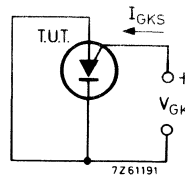

Fig. 5b.

Anode voltage

$I_A = 100 \text{ mA}$

$I_A = 180 \text{ mA}$

$V_A < 1,4 \text{ V}$

$V_A < 1,6 \text{ V}$

Peak output voltage

$V_{AA} = 20 \text{ V}; C = 200 \text{ nF}$ (see Fig. 12)

$V_{OM} > 6 \text{ V}$

Rise time

$V_{AA} = 20 \text{ V}; C = 10 \text{ nF}$ (see Fig. 12)

$t_r < 80 \text{ ns}$

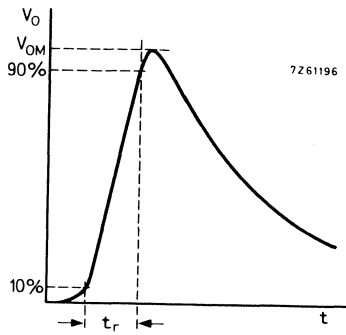

Fig. 6 Output voltage waveform.

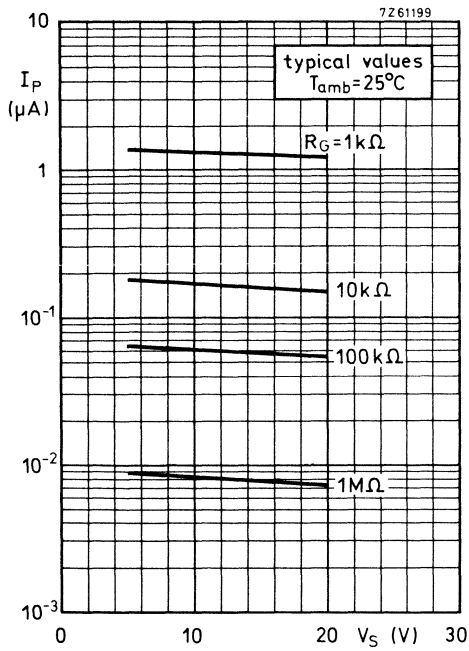

Fig. 7.

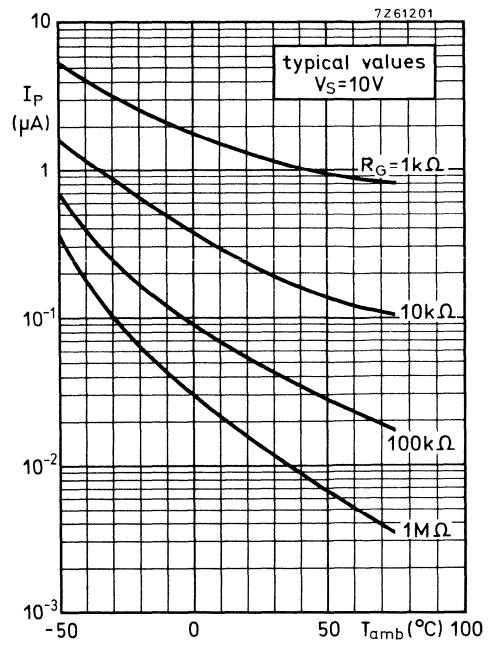

Fig. 8.

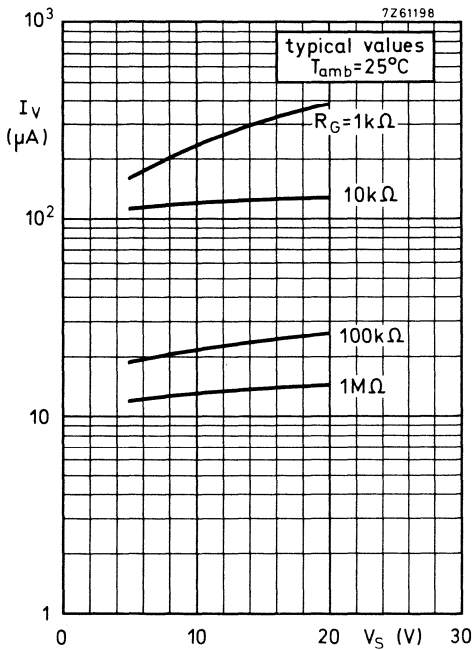

Fig. 9.

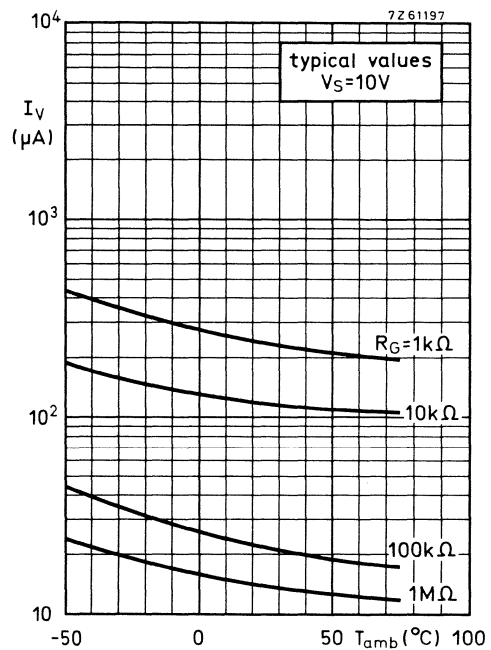

Fig. 10.

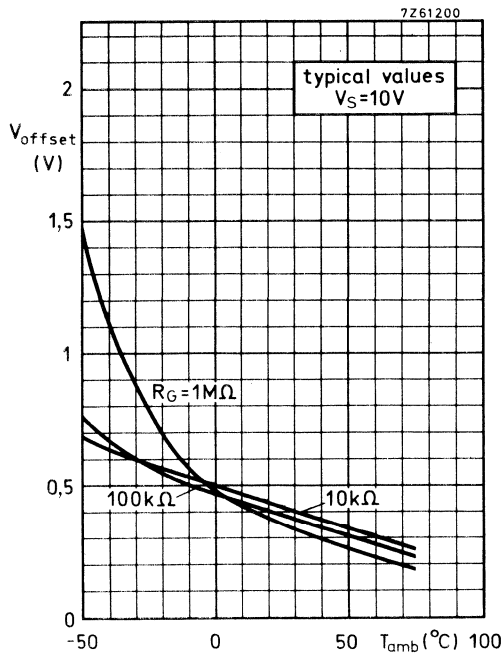

Fig. 11.

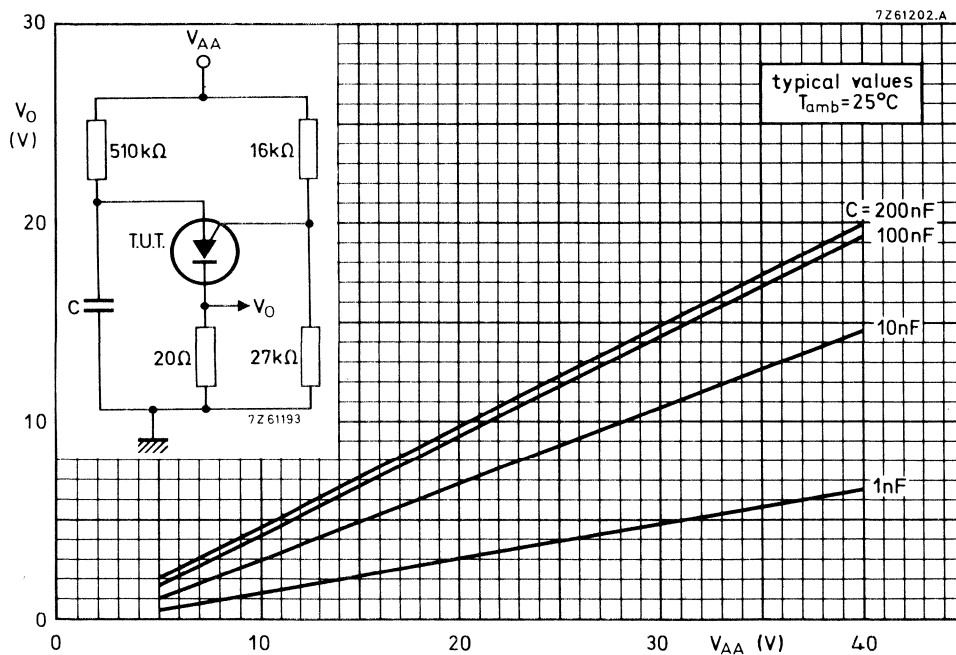

Fig. 12.

SILICON P-N-P-N PLANAR TETRODE THYRISTOR

Planar p-n-p-n trigger device in a microminiature plastic envelope. It is intended for use as a programmable trigger device (SCS = silicon controlled switch).

QUICK REFERENCE DATA

Anode gate – cathode voltage	V_{ga-kR}	max.	70 V
Anode gate – anode voltage (open cathode)	V_{ga-aO}	max.	70 V
Average anode current	$I_A(AV)$	max.	175 mA
Total power dissipation at $T_{amb} = 25\text{ }^\circ\text{C}$	P_{tot}	max.	275 mW
Junction temperature	T_j	max.	150 $^\circ\text{C}$
Gate-controlled turn-on time $R_{gk-k} = 1\text{ k}\Omega$	t_{gt}	<	0,25 μs
Circuit-commutated turn-off time $R_{gk-k} = 1\text{ k}\Omega$	t_{q}	<	5 μs

MECHANICAL DATA

Fig. 1 SOT-143.

Dimensions in mm

Marking code

BRY62 = A51

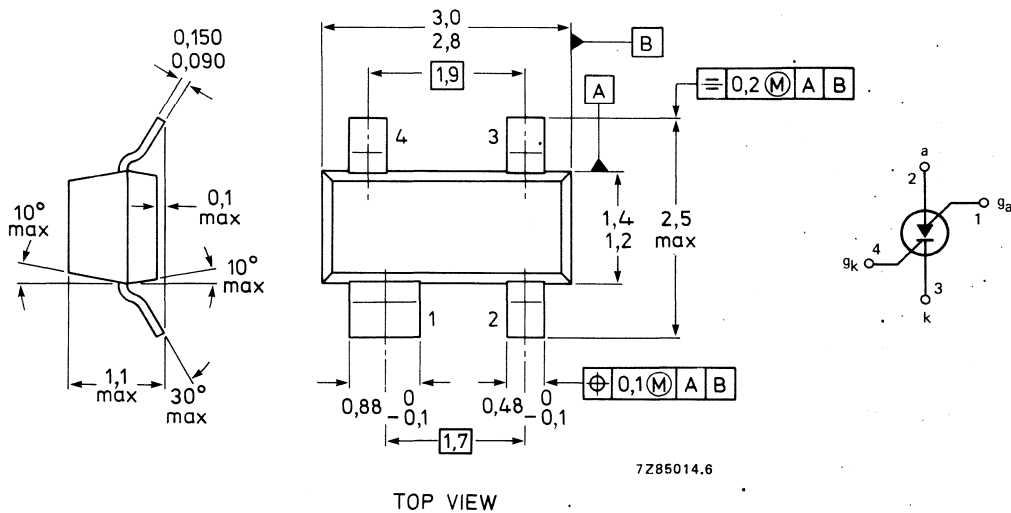

See also *Soldering recommendations*.

RATINGS

Limiting values in accordance with the Absolute Maximum System (IEC 134)

Transistor 1 (T1)

Collector-base voltage (open emitter)	V_{CBO}	max.	70 V
Collector-emitter voltage ($R_{BE} = 10 \text{ k}\Omega$)	V_{CEO}	max.	70 V
Emitter-collector voltage ($I_{C1} = 0$)	V_{EBO}	max.	5 V
Average collector current	$I_{C(AV)}$	max.	175 mA [▲]
Collector current (peak value)	I_{CM}	max.	175 mA ^{**}
Average emitter current	$I_{E(AV)}$	max.	175 mA
Emitter current (peak value) $t_p = 10 \mu\text{s}; \delta = 1\%$	I_{EM}	max.	2,5 A

Transistor 2 (T2)

Collector-base voltage ($I_{E2} = 0$)	$-V_{CBO}$	max.	70 V
Collector-emitter voltage ($I_{B2} = 0$)	$-V_{CEO}$	max.	70 V
Emitter-base voltage ($I_{C2} = 0$)	$-V_{EBO}$	max.	70 V
Emitter current (average)	$I_{E(AV)}$	max.	175 mA
Emitter current (peak value) $t_p = 10 \mu\text{s}; \delta = 1\%$	I_{EM}	max.	2,5 A
Reverse gate to cathode voltage	V_{ga-kR}	max.	70 V
Gate to anode voltage (open cathode)	V_{ga-aO}	max.	70 V
Gate to cathode voltage (open anode)	V_{gk-kO}	max.	5 V
Average anode current	$I_{A(AV)}$	max.	175 mA
Anode current (peak value) $t_p = 10 \mu\text{s}; \delta = 1\%$	I_{AM}	max.	2,5 A
Anode gate current (average)	$I_{GA(AV)}$	max.	175 mA
Anode gate current (peak value)	I_{GAM}	max.	**
Total power dissipation at $T_{amb} = 25 \text{ }^\circ\text{C}$ *	P_{tot}	max.	275 mW
Junction temperature	T_j	max.	150 $^\circ\text{C}$
Storage temperature	T_{stg}		-65 to + 150 $^\circ\text{C}$

THERMAL RESISTANCE

From junction to ambient*	$R_{th \text{ j-a}}$	=	450 K/W
---------------------------	----------------------	---	---------

* Device mounted on a ceramic substrate of 15 mm x 15 mm x 0,5 mm.

** During switching on, the device can withstand the discharge of a capacitor of maximum value of 500 pF. This capacitor is charged when the transistor is in cut-off condition, with a collector supply voltage of 160 V and a series resistance of 100 k Ω .▲ Provided the I_E rating is not exceeded.

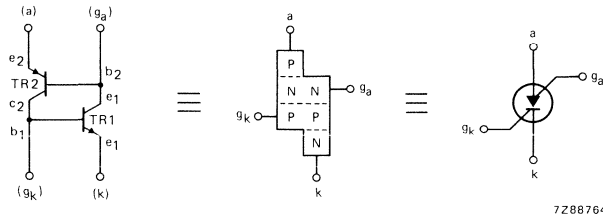

Fig. 2 Circuit diagram.

CHARACTERISTICS

$T_j = 25\text{ }^\circ\text{C}$ unless otherwise specified.

Transistor 1 (TR1)

Collector-emitter cut-off current

$$V_{CE} = 60\text{ V}; R_{BE} = 10\text{ k}\Omega$$

$$V_{CE} = 70\text{ V}; R_{BE} = 10\text{ k}\Omega; T_j = 150\text{ }^\circ\text{C}$$

Emitter cut-off current

$$V_{EB} = 5\text{ V}; I_C = 0; T_j = 150\text{ }^\circ\text{C}$$

Saturation voltages

$$I_C = 10\text{ mA}; I_B = 1\text{ mA}$$

D.C. current gain

$$V_{CE} = 2\text{ V}; I_C = 10\text{ mA}$$

Collector capacitance

$$V_{CB} = 20\text{ V}; I_E = I_e = 0$$

Emitter capacitance

$$V_{EB} = 1\text{ V}; I_C = I_c = 0$$

Transition frequency at $f = 100\text{ MHz}$

$$V_{CE} = 2\text{ V}; I_C = 10\text{ mA}$$

Transistor 2 (TR2)

Collector-emitter cut-off current

$$-V_{CE} = 70\text{ V}; I_B = 0; T_j = 150\text{ }^\circ\text{C}$$

Emitter cut-off current

$$-V_{EB} = 70\text{ V}; I_C = I_c = 0; T_j = 150\text{ }^\circ\text{C}$$

D.C. current gain

$$V_{CB} = 0\text{ V}; I_E = 1\text{ mA}$$

$$I_{CER} < 100\text{ nA}$$

$$I_{CER} < 10\text{ }\mu\text{A}$$

$$I_{EBO} < 10\text{ }\mu\text{A}$$

$$V_{CEsat} < 0,5\text{ V}$$

$$V_{BEsat} < 0,9\text{ V}$$

$$h_{FE} > 50$$

$$C_c < 5\text{ pF}$$

$$C_e < 25\text{ pF}$$

$$f_T = 300\text{ MHz}$$

$$-I_{CEO} < 10\text{ }\mu\text{A}$$

$$-I_{EBO} < 10\text{ }\mu\text{A}$$

$$h_{FE} \quad 0,25\text{ to }2,5$$

THYRISTOR

Anode to cathode

On-state voltage

$I_A = 50 \text{ mA}; I_{ga} = 0; R_{gk-k} = 10 \text{ k}\Omega$

$V_T < 1,4 \text{ V}$

$I_A = 1 \text{ mA}; I_{ga} = 10 \text{ mA}; R_{gk-k} = 10 \text{ k}\Omega$

$V_T < 1,2 \text{ V}$

Holding current

$I_{ga} = 10 \text{ mA}; -V_{gk} = 2 \text{ V}; R_{gk-k} = 10 \Omega$

$I_H < 1 \text{ mA}$

Switching characteristics

Gate-controlled turn-on time ($t_{gt} = t_d + t_r$)
 when switched from $V_{gk} = -0,5 \text{ V}$ to $4,5 \text{ V}$
 at $R_{gk-k} = 1 \text{ k}\Omega$
 at $R_{gk-k} = 10 \text{ k}\Omega$

$t_{gt} < 0,25 \mu\text{s}$

$t_{gt} < 1,5 \mu\text{s}$

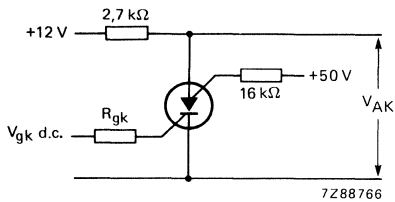

Fig. 3 Switching times test circuit.
 The pulse time of V_{gk} can be adjusted
 in such a way that the broken line in Fig. 4
 disappears, which means that the thyristor
 starts triggering.

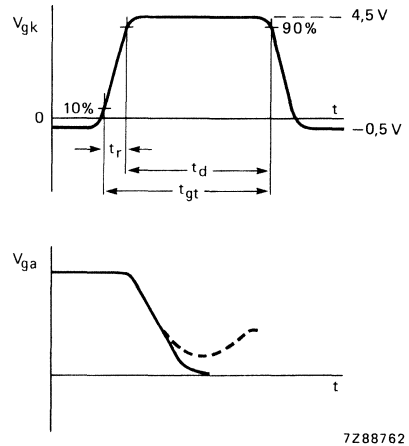

Fig. 4 Switching times waveforms.

Turn-off time (Figs 5 and 6)

$R_{gk} = 1 \text{ k}\Omega$

$R_{gk} = 10 \text{ k}\Omega$

$R_{gk} = 10 \text{ k}\Omega; T_j = 125 \text{ }^\circ\text{C}$

t_q	<	$5 \mu\text{s}$
t_q	<	$8 \mu\text{s}$
t_q	<	$15 \mu\text{s}$

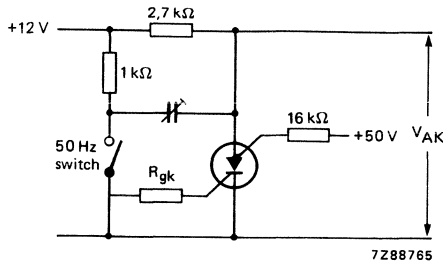

Fig. 5 Switching times test circuit.

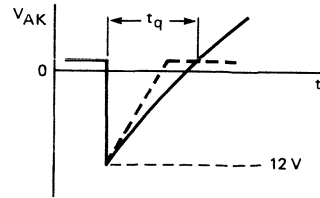

Fig. 6 Switching times waveforms.

The capacitor can be adjusted in such a way that the broken line disappears, which means that the thyristor will not trigger any more.

MOSFET N-CHANNEL DEPLETION SWITCHING TRANSISTORS

Symmetrical insulated-gate silicon MOS field-effect transistors of the N-channel depletion mode type. The transistor is sealed in a SOT-143 envelope and features a low ON-resistance and low capacitances. The transistor is protected against excessive input voltages by integrated back-to-back diodes between gate and substrate.

Applications:

- analog and/or digital switch
- switch driver
- convertor
- chopper

QUICK REFERENCE DATA

		BSD20	BSD22
Drain-source voltage	V_{DS} max.	10	20 V
Gate-source voltage	V_{GS} max.	+ 10 -30	+ 20 V -40 V
Drain current (d.c.)	I_D max.	50	mA
Total power dissipation up to $T_{amb} = 25\text{ }^{\circ}\text{C}$	P_{tot} max.	230	mW
Junction temperature	T_j max.	125	$^{\circ}\text{C}$
Drain-source ON-resistance $V_{GS} = 10\text{ V}; V_{SB} = 0; I_D = 1\text{ mA}$	R_{DSon}	< 30	Ω
Feed-back capacitance $V_{GS} = V_{BS} = -5\text{ V}; V_{DS} = 10\text{ V}; f = 1\text{ MHz}$	C_{rss} typ.	0,6	pF

MECHANICAL DATA

Dimensions in mm

Fig. 1 SOT-143.

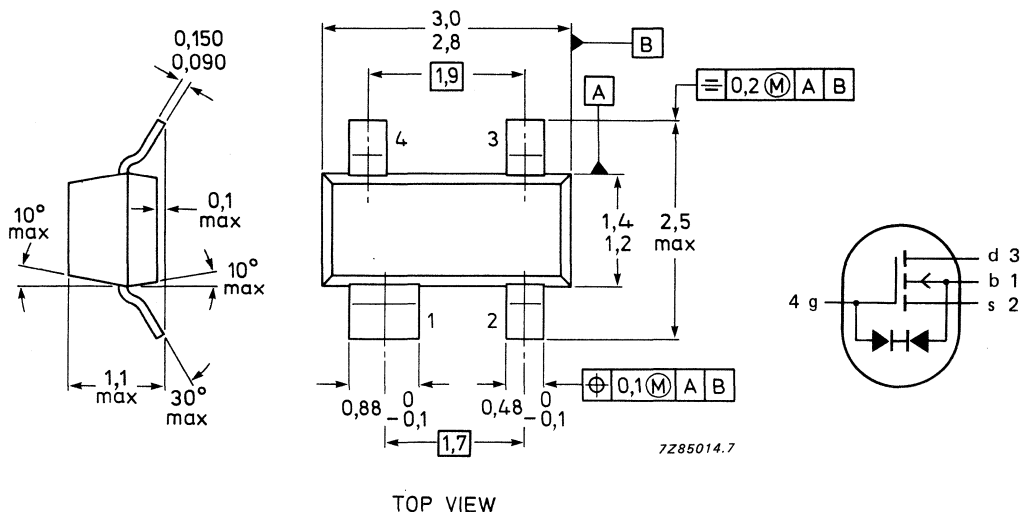

RATINGS

Limiting values in accordance with the Absolute Maximum System (IEC 134)

			BSD20	BSD22
Drain-source voltage	V_{DS}	max.	10	20 V
Source-drain voltage	V_{SD}	max.	10	20 V
Drain-substrate voltage	V_{DB}	max.	15	25 V
Source-substrate voltage	V_{SB}	max.	15	25 V
Gate-substrate voltage	V_{GB}	max.	± 15	± 25 V
Gate-source voltage	V_{GS}	max.	+15 -30	+15 V -40 V
Drain current (d.c.)	I_D	max.	50	mA
Total power dissipation up to $T_{amb} = 25\text{ }^\circ\text{C}^*$	P_{tot}	max.	230	mW
Storage temperature	T_{stg}		-65 to +150	$^\circ\text{C}$
Junction temperature	T_j	max.	125	$^\circ\text{C}$

THERMAL RESISTANCE

From junction to ambient in free air*	$R_{th\ j-a}$	=	430	K/W
---------------------------------------	---------------	---	-----	-----

CHARACTERISTICS

$T_{amb} = 25\text{ }^\circ\text{C}$ unless otherwise specified

			BSD20	BSD22
Drain-source breakdown voltage $V_{GS} = V_{BS} = -5\text{ V}; I_S = 10\text{ nA}$	$V_{(BR)DSX}$	>	10	20 V
Source-drain breakdown voltage $V_{GD} = V_{BD} = -5\text{ V}; I_D = 10\text{ nA}$	$V_{(BR)SDX}$	>	10	20 V
Drain-substrate breakdown voltage $V_{GB} = 0; I_D = 10\text{ nA};$ open source	$V_{(BR)DBO}$	>	15	25 V
Source-substrate breakdown voltage $V_{GB} = 0; I_S = 10\text{ nA};$ open drain	$V_{(BR)SBO}$	>	15	25 V
Drain-source leakage current $V_{GS} = V_{BS} = -5\text{ V}; V_{DS} = 10\text{ V}$	I_{DSoff}	typ.	1,0	nA
Source-drain leakage current $V_{GD} = V_{BD} = 5\text{ V}; V_{SD} = 10\text{ V}$	I_{SDoff}	typ.	1,0	nA
Gate-substrate leakage current $V_{DB} = V_{SB} = 0; V_{GB} = \pm 15\text{ V}$	I_{GSoff}	<	10	nA

* Device mounted on a ceramic substrate of 8 mm x 10 mm x 0,7 mm.

Forward transconductance at $f = 1 \text{ kHz}$

$V_{DS} = 10 \text{ V}; V_{SB} = 0; I_D = 20 \text{ mA}$

$g_{fs} > 10 \text{ mS}$
typ. 15 mS

Gate-source cut-off voltage

$V_{DS} = 10 \text{ V}; V_{SB} = 0; I_S = 10 \mu\text{A}$

$I_S = 10 \mu\text{A}$

$-V_{(P)GS} < 2.0 \text{ V}$

Drain-source ON-resistance

$I_D = 1 \text{ mA}; V_{SB} = 0;$

$V_{GS} = 5 \text{ V}$

$r_{DSon} \text{ typ. } 25 \Omega$
 $< 50 \Omega$

$V_{GS} = 10 \text{ V}$

$r_{DSon} \text{ typ. } 15 \Omega$
 $< 30 \Omega$

Capacitances at $f = 1 \text{ MHz}$

$V_{GS} = V_{BS} = -5 \text{ V}; V_{DS} = 10 \text{ V}$

Feed-back capacitance

$C_{rss} \text{ typ. } 0,6 \text{ pF}$

Input capacitance

$C_{iss} \text{ typ. } 1,5 \text{ pF}$

Output capacitance

$C_{oss} \text{ typ. } 1,0 \text{ pF}$

Switching times (see Fig. 2)

$V_{DD} = 10 \text{ V}; V_i = -5 \text{ V to } 0 \text{ V}$

$t_{on} \text{ typ. } 1,0 \text{ ns}$
 $t_{off} \text{ typ. } 5,0 \text{ ns}$

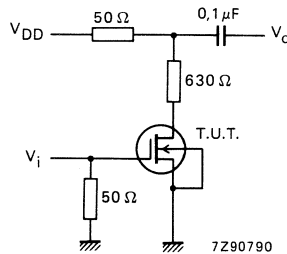

Fig. 2 Switching times test circuit.

SILICON LOW-POWER SWITCHING TRANSISTORS

P-N-P silicon transistor in a microminiature plastic envelope. It is intended for high-speed, saturated switching applications for industrial service in thick and thin-film circuits.

QUICK REFERENCE DATA

Collector-base voltage (open emitter)	$-V_{CBO}$	max.	15 V
Collector-emitter voltage (open base)	$-V_{CEO}$	max.	15 V
Collector current (peak value)	$-I_{CM}$	max.	200 mA
Total power dissipation up to $T_{amb} = 65\text{ }^{\circ}\text{C}$	P_{tot}	max.	250 mW
Junction temperature	T_j	max.	175 $^{\circ}\text{C}$
D.C. current gain			
$-I_C = 10\text{ mA}; -V_{CE} = 1\text{ V}$	h_{FE}	>	30
$-I_C = 50\text{ mA}; -V_{CE} = 1\text{ V}$	h_{FE}		30 to 120
Transition frequency at $f = 500\text{ MHz}$			
$-I_C = 50\text{ mA}; -V_{CE} = 10\text{ V}$	f_T	>	1,5 GHz
Turn-off time			
$-I_{Con} = 30\text{ mA}; -I_{Bon} = +I_{Boff} = 3,0\text{ mA}$	t_{off}	<	30 ns

MECHANICAL DATA

Dimensions in mm

Marking code

Fig. 1 SOT-23.

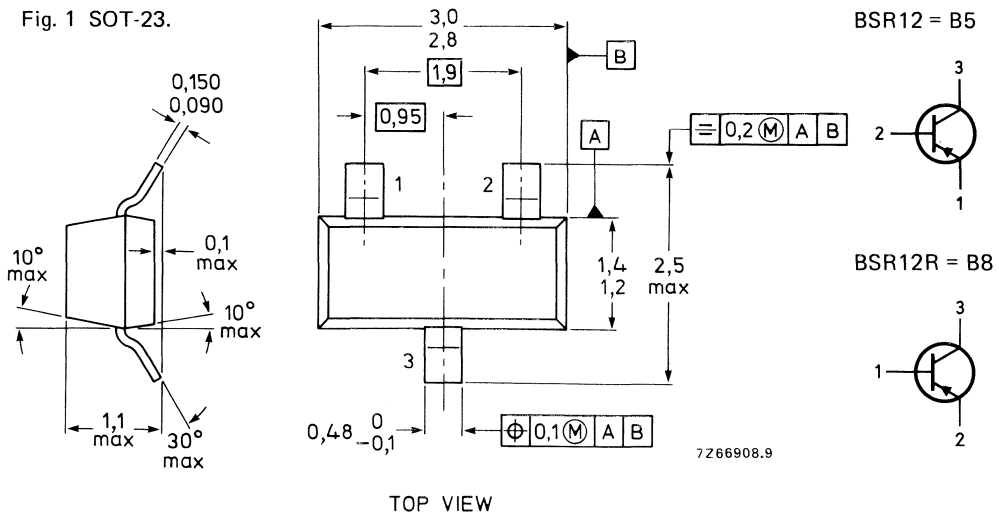

R-types are available on request

See also *Soldering recommendations*.

RATINGS

Limiting values in accordance with the Absolute Maximum System (IEC 134)

Collector-base voltage (open emitter) See Fig. 3	$-V_{CBO}$	max.	15 V
Collector-emitter voltage (open base) See Fig. 3	$-V_{CEO}$	max.	15 V
Emitter-base voltage (open collector) See Fig. 3	$-V_{EBO}$	max.	3 V
Collector current (d.c.)	$-I_C$	max.	100 mA
Collector current (peak value)	$-I_{CM}$	max.	200 mA
Total power dissipation up to $T_{amb} = 65\text{ }^{\circ}\text{C}^{**}$	P_{tot}	max.	250 mW
Storage temperature	T_{stg}		-65 to $+175\text{ }^{\circ}\text{C}$
Junction temperature	T_j	max.	$175\text{ }^{\circ}\text{C}$

THERMAL CHARACTERISTICS*

$$T_j = P \times (R_{th\ j-t} + R_{th\ t-s} + R_{th\ s-a}) + T_{amb}$$

Thermal resistance

From junction to tab	$R_{th\ j-t}$	=	60 K/W
From tab to soldering points	$R_{th\ t-s}$	=	280 K/W
From soldering points to ambient**	$R_{th\ s-a}$	=	90 K/W

CHARACTERISTICS $T_{amb} = 25\text{ }^{\circ}\text{C}$ unless otherwise specified

Collector cut-off current

$I_E = 0; -V_{CB} = 10\text{ V}$	$-I_{CBO}$	<	50 nA
$I_E = 0; -V_{CB} = 10\text{ V}; T_{amb} = 125\text{ }^{\circ}\text{C}$	$-I_{CBO}$	<	5 μA
$V_{BE} = 0; -V_{CE} = 10\text{ V}$	$-I_{CES}$	<	50 nA

Breakdown voltages

$I_E = 0; -I_C = 10\text{ }\mu\text{A}$	$-V_{(BR)CBO}$	>	15 V
$V_{BE} = 0; -I_C = 10\text{ }\mu\text{A}$	$-V_{(BR)CES}$	>	15 V
$I_C = 0; -I_E = 100\text{ }\mu\text{A}$	$-V_{(BR)EBO}$	>	3 V

Collector-emitter sustaining voltage

$I_B = 0; -I_C = 10\text{ mA}$	$-V_{CEO\text{sust}}$	>	15 V
--------------------------------	-----------------------	---	------

Saturation voltages \blacktriangle

$-I_C = 10\text{ mA}; -I_B = 1\text{ mA}$	$-V_{CE\text{sat}}$	<	130 mV
	$-V_{BE\text{sat}}$		725 to 920 mV
$-I_C = 50\text{ mA}; -I_B = 5\text{ mA}$	$-V_{CE\text{sat}}$	typ.	180 mV
		<	270 mV
	$-V_{BE\text{sat}}$		800 to 1150 mV
$-I_C = 100\text{ mA}; -I_B = 10\text{ mA}$	$-V_{CE\text{sat}}$	<	450 mV
	$-V_{BE\text{sat}}$		900 to 1500 mV

 \blacktriangle Measured under pulse conditions; $t_p = 300\text{ }\mu\text{s}$; $\delta = 0,01$.* See *Thermal characteristics*.

** Mounted on a ceramic substrate of 8 mm x 10 mm x 0,7 mm.

D.C. current gain *

- $-I_C = 1 \text{ mA}; -V_{CE} = 1 \text{ V}$
- $-I_C = 10 \text{ mA}; -V_{CE} = 1 \text{ V}$
- $-I_C = 50 \text{ mA}; -V_{CE} = 1 \text{ V}$
- $-I_C = 50 \text{ mA}; -V_{CE} = 1 \text{ V}; T_{amb} = 55 \text{ }^\circ\text{C}$
- $-I_C = 100 \text{ mA}; -V_{CE} = 1 \text{ V}$

- $h_{FE} > 30$
- $h_{FE} > 30$
- $h_{FE} 30 \text{ to } 120$
- $h_{FE} > 30$
- $h_{FE} > 20$

Transition frequency at $f = 500 \text{ MHz}$

- $-I_C = 50 \text{ mA}; -V_{CE} = 10 \text{ V}$

- $f_T > 1,5 \text{ GHz}$

Collector capacitance

- $I_E = I_e = 0; -V_{CB} = 5 \text{ V}$

- $C_c < 4,5 \text{ pF}$

Emitter capacitance

- $I_C = I_c = 0; -V_{EB} = 0,5 \text{ V}$

- $C_e < 6,0 \text{ pF}$

Switching times

Turn-on time

- $t_{on} < 20 \text{ ns}$

Turn-off time

- $t_{off} < 30 \text{ ns}$

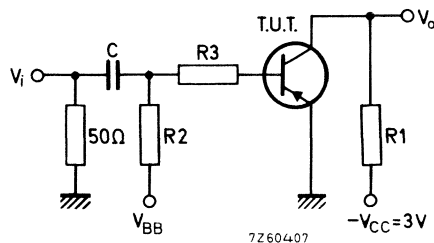

Fig. 2 Test circuit switching times.

Pulse generator

- Pulse duration $t_p = 400 \text{ ns}$
- Rise time $t_r < 1 \text{ ns}$
- Output impedance $Z_o = 50 \text{ } \Omega$

Sampling scope

- Rise time $t_r < 1 \text{ ns}$
- Input impedance $Z_i = 100 \text{ k}\Omega$

	V_i V	V_{BB} V	R1 Ω	R2 k Ω	R3 k Ω	$-I_{Con}$ mA	$-I_{Bon}$ mA	I_{Boff} mA	C μF
t_{on}	-6,85	0	94	1,0	2,0	30	3,0	-	0,1
t_{off}	11,7	-9,85	94	1,0	2,0	30	3,0	3,0	0,1

* Measured under pulse conditions; $t_p = 300 \text{ } \mu\text{s}; \delta = 0,01$.

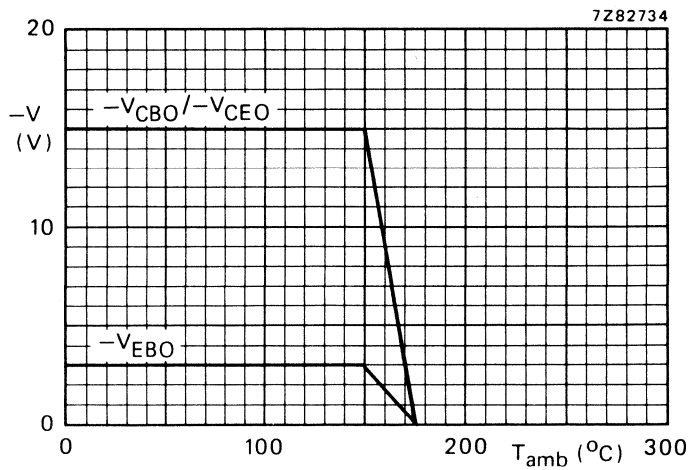

Fig. 3 Voltage derating curves.

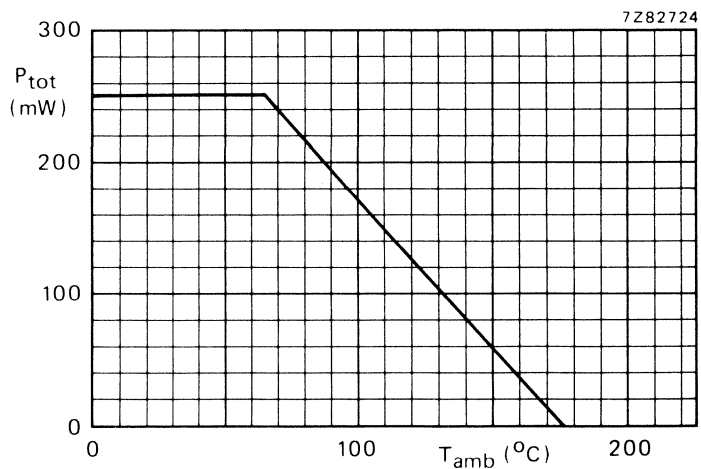

Fig. 4 Power derating curve.

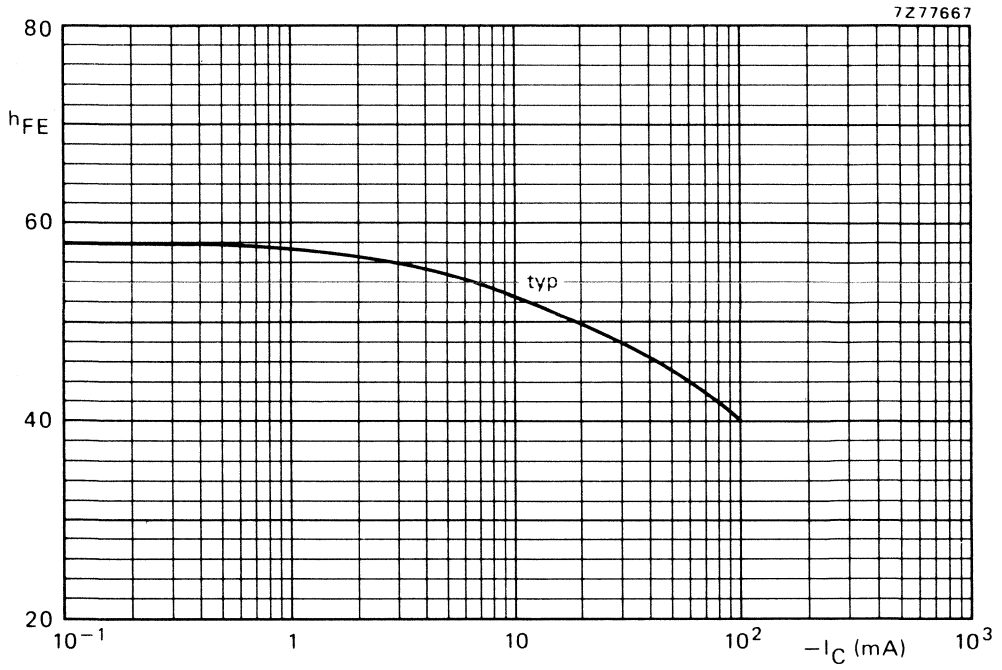

Fig. 5 $-V_{CE} = 1\text{ V}$; $T_{amb} = 25\text{ }^\circ\text{C}$.

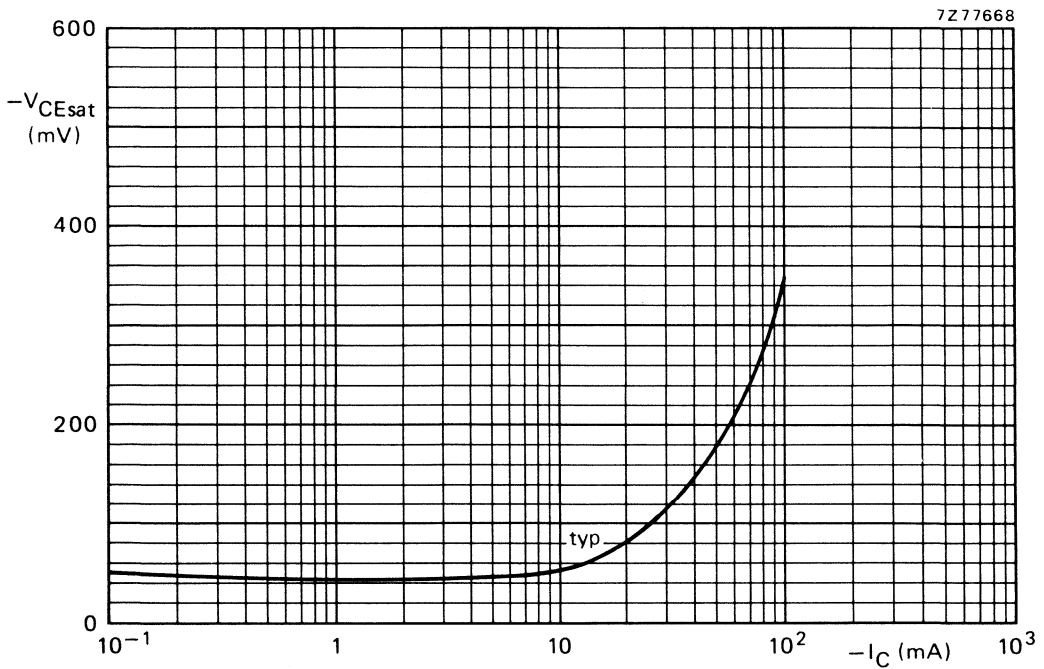

Fig. 6 V_{CEsat} as a function of I_C at $I_C/I_B = 10$.

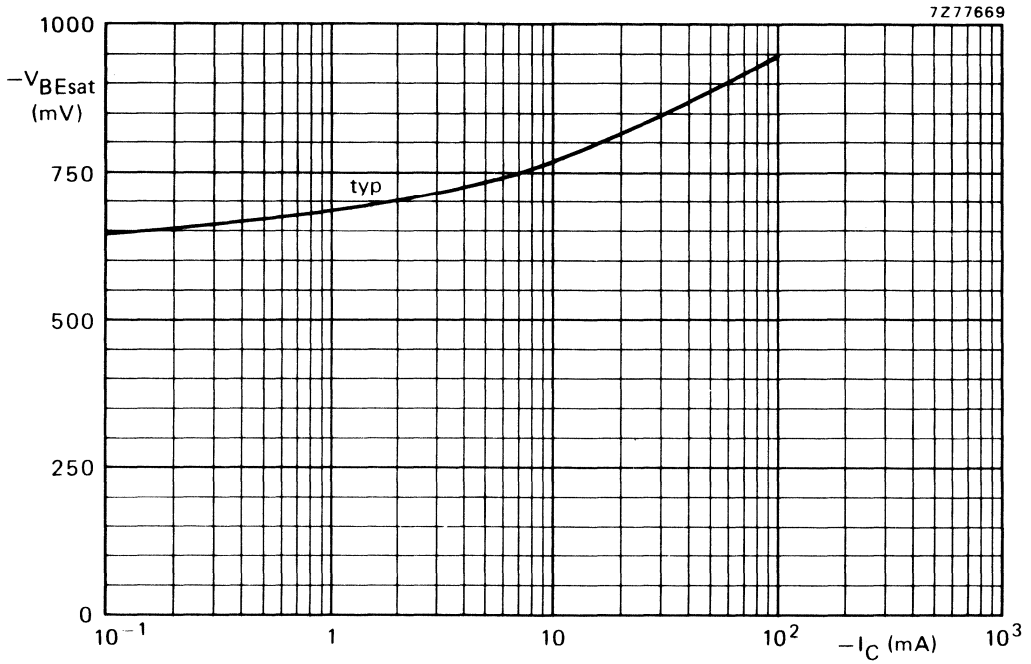

Fig. 7 V_{BEsat} as a function of I_C at $I_C/I_B = 10$.

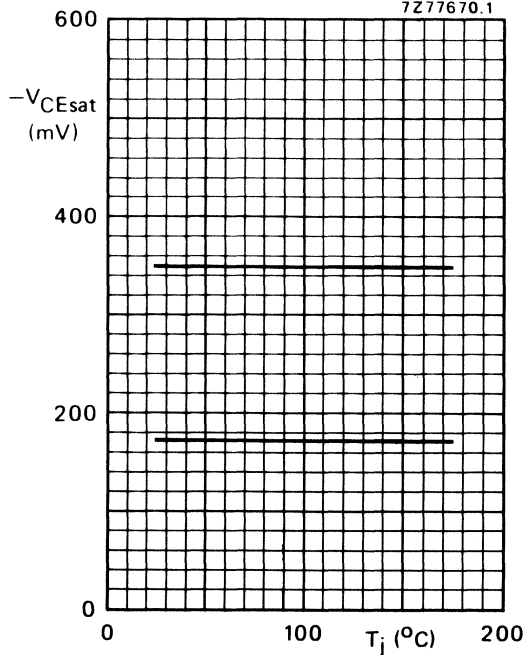

Fig. 8 V_{CEsat} as a function of T_j ; typical values.

Upper graph at $I_C = 100$ mA; $I_B = 10$ mA. Lower graph at $I_C = 50$ mA and $I_B = 5$ mA.

SILICON PLANAR EPITAXIAL TRANSISTORS

N-P-N silicon transistors, in a microminiature plastic envelope intended for switching and linear applications in thick and thin-film circuits.

QUICK REFERENCE DATA

		BSR13	BSR14
Collector-base voltage (open emitter)	V_{CB0}	max. 60	75 V
Collector-emitter voltage (open base)	V_{CE0}	max. 30	40 V
Emitter-base voltage (open collector)	V_{EBO}	max. 5	6 V
Collector current (d.c.)	I_C	max. 800	mA
Total power dissipation up to $T_{amb} = 25\text{ }^\circ\text{C}$	P_{tot}	max. 425	mW
Junction temperature	T_j	max. 175	$^\circ\text{C}$
D.C. current gain		100 to 300	
$I_C = 150\text{ mA}; V_{CE} = 10\text{ V}$	h_{FE}	> 30	40
$I_C = 500\text{ mA}; V_{CE} = 10\text{ V}$	h_{FE}	> 30	40
Transition frequency at $f = 100\text{ MHz}$		300 MHz	
$I_C = 20\text{ mA}; V_{CE} = 20\text{ V}$	f_T	> 250	300 MHz

MECHANICAL DATA

Fig. 1 SOT-23.

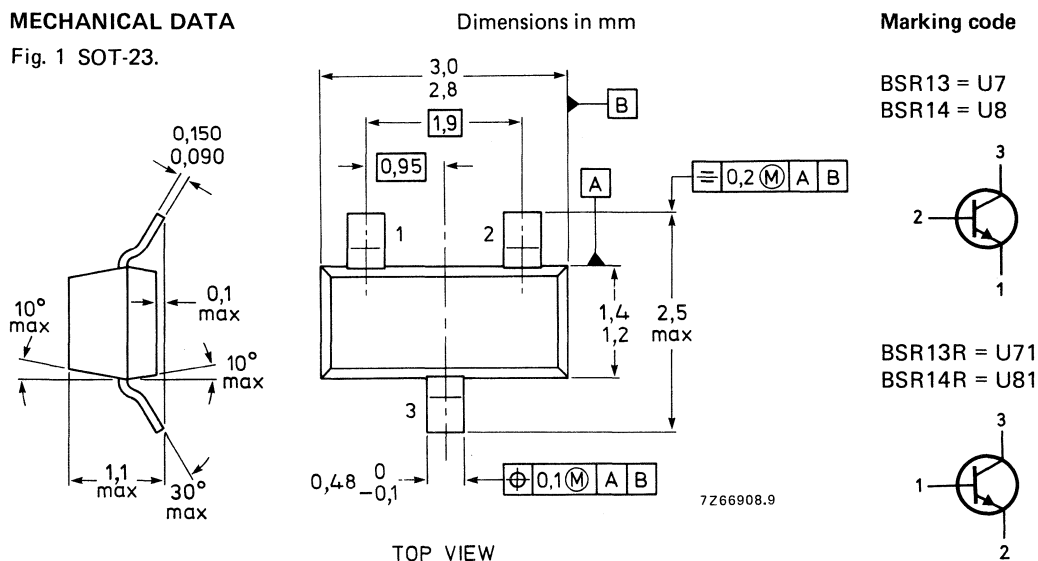

R-types are available on request.

See also Soldering recommendations.

RATINGS

Limiting values in accordance with the Absolute Maximum System (IEC 134)

			BSR13	BSR14	
Collector-base voltage (open emitter) see Fig. 4	V_{CBO}	max.	60	75	V
Collector-emitter voltage (open base) see Fig. 4	V_{CEO}	max.	30	40	V
Emitter-base voltage (open collector) see Fig. 4	V_{EBO}	max.	5	6	V
Collector current (d.c.)	I_C	max.	800		mA
Total power dissipation** up to $T_{amb} = 25\text{ }^\circ\text{C}$	P_{tot}	max.	425		mW
Storage temperature	T_{stg}		-65 to +175		$^\circ\text{C}$
Junction temperature	T_j	max.	175		$^\circ\text{C}$

THERMAL CHARACTERISTICS*

$$T_j = P \times (R_{th\ j-t} + R_{th\ t-s} + R_{th\ s-a}) + T_{amb}$$

Thermal resistance

From junction to tab	$R_{th\ j-t}$	=	30	K/W
From tab to soldering points	$R_{th\ t-s}$	=	260	K/W
From soldering points to ambient**	$R_{th\ s-a}$	=	60	K/W

CHARACTERISTICS

$T_j = 25\text{ }^\circ\text{C}$ unless otherwise specified

			BSR13	BSR14	
Collector cut-off current					
$I_E = 0; V_{CB} = 50\text{ V}$	I_{CBO}	<	30	—	nA
$I_E = 0; V_{CB} = 60\text{ V}$	I_{CBO}	<	—	10	nA
$I_E = 0; V_{CB} = 50\text{ V}; T_j = 150\text{ }^\circ\text{C}$	I_{CBO}	<	10	—	μA
$I_E = 0; V_{CB} = 60\text{ V}; T_j = 150\text{ }^\circ\text{C}$	I_{CBO}	<	—	10	μA
$V_{EB} = 3\text{ V}; V_{CE} = 60\text{ V}$	I_{CEX}	<	—	10	nA
Base current					
with reverse biased emitter junction					
$V_{EB} = 3\text{ V}; V_{CE} = 60\text{ V}$	I_{BEX}	<	—	20	nA
Emitter cut-off current					
$I_C = 0; V_{EB} = 3\text{ V}$	I_{EBO}	<	30	15	nA
Saturation voltages ▲					
$I_C = 150\text{ mA}; I_B = 15\text{ mA}$	V_{CEsat}	<	400	300	mV
	V_{BEsat}	<	1300	—	mV
	V_{BEsat}		—	0,6 to 1,2	V
$I_C = 500\text{ mA}; I_B = 50\text{ mA}$	V_{CEsat}	<	1600	1000	mV
	V_{BEsat}	<	2600	2000	mV

* See *Thermal characteristics*.

** Device mounted on a ceramic substrate of 15 mm x 15 mm x 0,7 mm.

▲ Measured under pulsed conditions to avoid excessive dissipation $t_p \leq 300\text{ }\mu\text{s}; \delta \leq 0,02$.

D.C. current gain *

$I_C = 0,1 \text{ mA}; V_{CE} = 10 \text{ V}$	h_{FE}	> 35	
$I_C = 1 \text{ mA}; V_{CE} = 10 \text{ V}$	h_{FE}	> 50	
$I_C = 10 \text{ mA}; V_{CE} = 10 \text{ V}$	h_{FE}	> 75	
$I_C = 150 \text{ mA}; V_{CE} = 10 \text{ V}$	h_{FE}	100 to 300	
$I_C = 150 \text{ mA}; V_{CE} = 1 \text{ V}$	h_{FE}	> 50	
$I_C = 500 \text{ mA}; V_{CE} = 10 \text{ V}$ BSR13; R	h_{FE}	> 30	
$I_C = 500 \text{ mA}; V_{CE} = 10 \text{ V}$ BSR14; R	h_{FE}	> 40	

Transition frequency at $f = 100 \text{ MHz}$

$I_C = 20 \text{ mA}; V_{CE} = 20 \text{ V}$ BSR13; R	f_T	> 250	MHz
$I_C = 20 \text{ mA}; V_{CE} = 20 \text{ V}$ BSR14; R	f_T	> 300	MHz

Collector capacitance at $f = 1 \text{ MHz}$

$I_E = I_e = 0; V_{CB} = 10 \text{ V}$	C_c	< 8	pF
--	-------	-------	----

h parameters (common emitter) at $f = 1 \text{ kHz}$

$I_C = 1 \text{ mA}; V_{CE} = 10 \text{ V}$	<u>BSR14</u>		
input impedance	h_{ie}	2 to 8	$k\Omega$
reverse voltage transfer ratio	h_{re}	$< 8 \cdot 10^{-4}$	
small signal current gain	h_{fe}	50 to 300	
output admittance	h_{oe}	5 to 35	μS
$I_C = 10 \text{ mA}; V_{CE} = 10 \text{ V}$			
input impedance	h_{ie}	0,25 to 1,25	$k\Omega$
reverse voltage transfer ratio	h_{re}	$< 4 \cdot 10^{-4}$	
small signal current gain	h_{fe}	75 to 375	
output admittance	h_{oe}	25 to 200	μS

* Measured under pulsed conditions to avoid excessive dissipation; pulse duration $t_p \leq 300 \mu s$; duty factor $\delta \leq 0,02$.

Switching times (between 10% and 90% levels)

Turn-on time switched to $I_C = 150 \text{ mA}$ (see Fig. 2)

delay time

rise time

Turn-off time switched from $I_C = 150 \text{ mA}$ (see Fig. 3)

storage time

fall time

BSR14

t_d	< 10 ns
t_r	< 25 ns

t_s	< 225 ns
t_f	< 60 ns

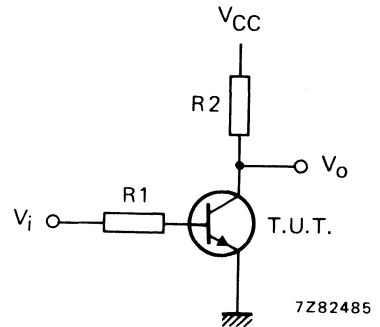
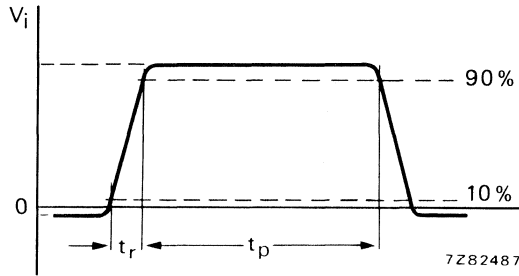

Fig. 2 Waveform and test circuit delay and rise time.

$V_i = -0,5 \text{ to } +9,9 \text{ V}$; $V_{CC} = 30 \text{ V}$; $R_1 = 619 \Omega$; $R_2 = 200 \Omega$.

Pulse generator:

pulse duration	$t_p \leq 200 \text{ ns}$
rise time	$t_r \leq 2 \text{ ns}$
duty factor	$\delta = 2\%$

Oscilloscope:

input impedance	$Z_i > 100 \text{ k}\Omega$
input capacitance	$C_i < 12 \text{ pF}$
rise time	$t_r < 5 \text{ ns}$

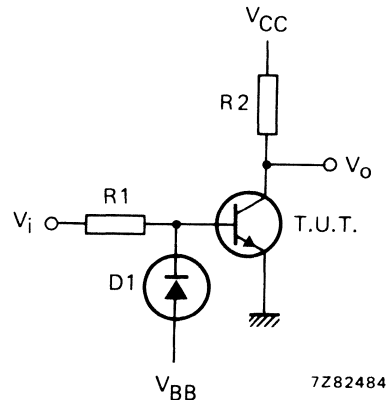
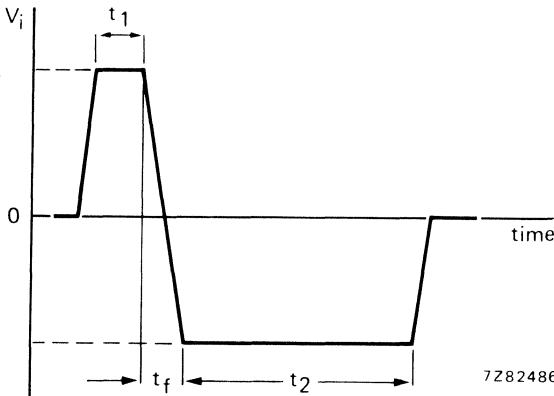

Fig. 3 Waveform and test circuit storage and fall time.

$V_i = -13,8 \text{ to } +16,2 \text{ V}$; $V_{CC} = 30 \text{ V}$; $-V_{BB} = 3 \text{ V}$; $R_1 = 1 \text{ k}\Omega$; $R_2 = 200 \Omega$.

Pulse generator:

fall time	$t_f < 5 \text{ ns}$
pulse time	$t_1 = 100 \mu\text{s}$
	$t_2 = 500 \mu\text{s}$

Oscilloscope:

input impedance	$Z_i > 100 \text{ k}\Omega$
input capacitance	$C_i < 12 \text{ pF}$
rise time	$t_r < 5 \text{ ns}$

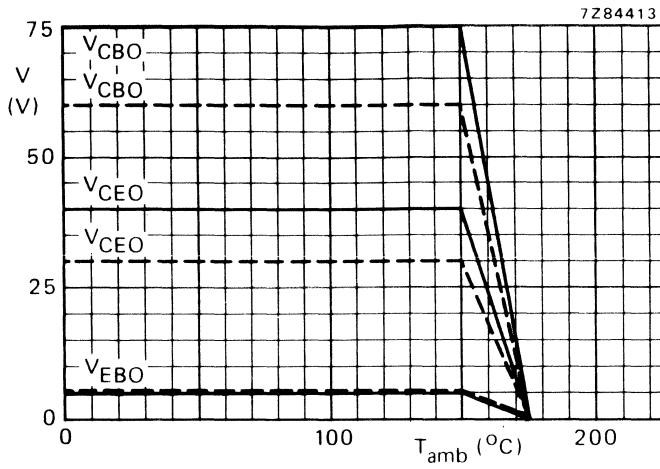

Fig. 4 Voltage derating curve.
--- BSR13 — BSR14.

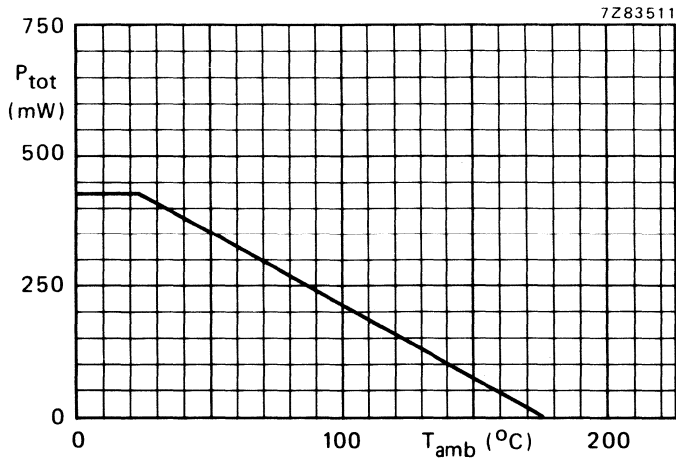

Fig. 5 Power derating curve.

SILICON PLANAR EPITAXIAL TRANSISTORS

P-N-P silicon transistors, in a microminiature plastic envelope, intended for medium power switching and general purpose amplifier applications in thick and thin-film circuits.

QUICK REFERENCE DATA

		BSR15		BSR16	
Collector-base voltage (open emitter)	$-V_{CB0}$	max.	60	60	V
Collector-emitter voltage (open base)	$-V_{CE0}$	max.	40	60	V
Emitter-base voltage (open collector)	$-V_{EB0}$	max.		5	V
Collector current (d.c.)	$-I_C$	max.	600		mA
Total power dissipation up to $T_{amb} = 25\text{ }^\circ\text{C}$	P_{tot}	max.	425		mW
Junction temperature	T_j	max.	175		$^\circ\text{C}$
D.C. current gain					
$-I_C = 500\text{ mA}; -V_{CE} = 10\text{ V}$	h_{FE}	>	30	50	
Turn-off switching time					
$-I_{Con} = 150\text{ mA}; -I_{Bon} = I_{Boff} = 15\text{ mA}$	t_{off}	>	100		ns
Transition frequency at $f = 100\text{ MHz}$					
$-I_C = 50\text{ mA}; -V_{CE} = 20\text{ V}$	f_T	>	200		MHz

MECHANICAL DATA

Fig. 1 SOT-23.

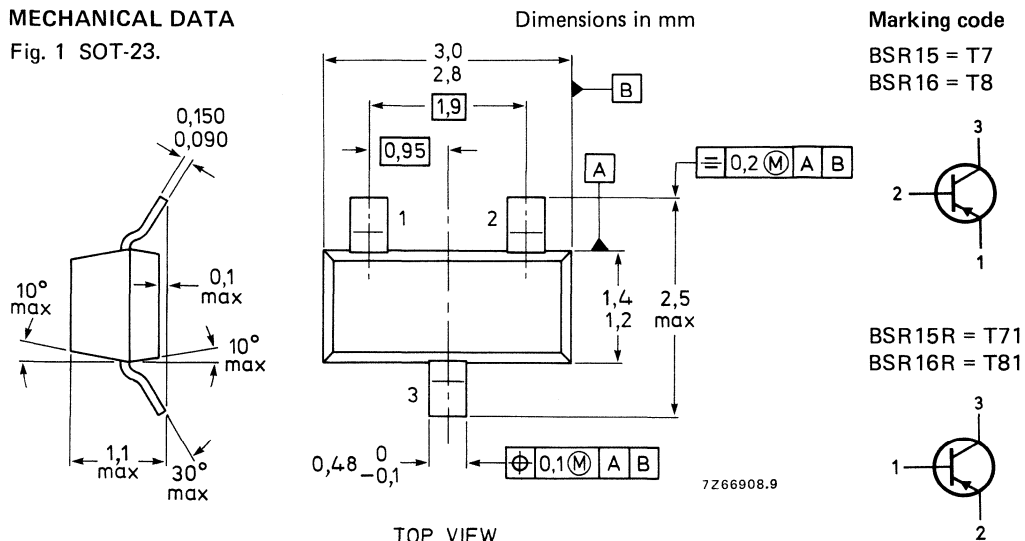

R-types are available on request.

See also Soldering recommendations.

RATINGS

Limiting values in accordance with the Absolute Maximum System (IEC 134)

		BSR15	BSR16	
Collector-base voltage (open emitter) See Figs 5 and 6	$-V_{CBO}$	max. 60	60	V
Collector-emitter voltage (open base) See Figs 5 and 6	$-V_{CEO}$	max. 40	60	V
Emitter-base voltage (open collector) See Figs 5 and 6	$-V_{EBO}$	max. 5	5	V
Collector current (d.c.)	$-I_C$	max. 600		mA
Power dissipation up to $T_{amb} = 25\text{ }^\circ\text{C}^{**}$	P_{tot}	max. 425		mW
Storage temperature	T_{stg}	-65 to + 175		$^\circ\text{C}$
Junction temperature	T_j	max. 175		$^\circ\text{C}$

THERMAL CHARACTERISTICS*

$$T_j = P \times (R_{th\ j-t} + R_{th\ t-s} + R_{th\ s-a}) + T_{amb}$$

Thermal resistance

From junction to tab	$R_{th\ j-t}$	=	30	K/W
From tab to soldering points	$R_{th\ t-s}$	=	260	K/W
From soldering points to ambient**	$R_{th\ s-a}$	=	60	K/W

CHARACTERISTICS

$T_j = 25\text{ }^\circ\text{C}$ unless otherwise specified

		BSR15	BSR16	
Collector cut-off current				
$I_E = 0; -V_{CB} = 50\text{ V}$	$-I_{CBO}$	< 20	10	nA
$I_E = 0; -V_{CB} = 50\text{ V}; T_j = 150\text{ }^\circ\text{C}$	$-I_{CBO}$	< 20	10	μA
$-V_{EB} = 0,5\text{ V}; -V_{CE} = 30\text{ V}$	$-I_{CEX}$	< 50		nA
Base current				
with reverse biased emitter junction				
$-V_{EB} = 3\text{ V}; -V_{CE} = 30\text{ V}$	$-I_{BEX}$	< 50		nA
Saturation voltages \blacktriangle				
$-I_C = 150\text{ mA}; -I_B = 15\text{ mA}$	$-V_{CEsat}$	< 0,4		V
	$-V_{BEsat}$	< 1,3		V
$-I_C = 500\text{ mA}; -I_B = 50\text{ mA}$	$-V_{CEsat}$	< 1,6		V
	$-V_{BEsat}$	< 2,6		V

* See *Thermal characteristics*.

** Device mounted on a ceramic substrate of 15 mm x 15 mm x 0,7 mm.

\blacktriangle Measured under pulsed conditions to avoid excessive dissipation pulse duration $t_p \leq 300\text{ }\mu\text{s}$; duty factor $\delta \leq 0,02$.

		BSR15	BSR16
D.C. current gain *			
$-I_C = 0,1 \text{ mA}; -V_{CE} = 10 \text{ V}$	$h_{FE} >$	35	75
$-I_C = 1 \text{ mA}; -V_{CE} = 10 \text{ V}$	$h_{FE} >$	50	100
$-I_C = 10 \text{ mA}; -V_{CE} = 10 \text{ V}$	$h_{FE} >$	75	100
$-I_C = 150 \text{ mA}; -V_{CE} = 10 \text{ V}$	h_{FE}	100 to 300	
$-I_C = 500 \text{ mA}; -V_{CE} = 10 \text{ V}$	$h_{FE} >$	30	50
Transition frequency at $f = 100 \text{ MHz}$			
$-I_C = 50 \text{ mA}; -V_{CE} = 20 \text{ V}; T_{amb} = 25 \text{ }^\circ\text{C}$	$f_T >$	200	MHz
Collector capacitance at $f = 1 \text{ MHz}$			
$I_E = I_e = 0; -V_{CB} = 10 \text{ V}$	$C_c <$	8	pF
Emitter capacitance at $f = 1 \text{ MHz}$			
$I_C = I_c = 0; -V_{EB} = 2 \text{ V}$	$C_e <$	30	pF
Switching times (between 10% and 90% levels)			
Turn-on time when switched to			
$-I_C = 150 \text{ mA}; -I_B = 15 \text{ mA};$ (see Fig. 3)			
delay time	$t_d <$	10	ns
rise time	$t_r <$	40	ns
turn-on time ($t_d + t_r$)	$t_{on} <$	45	ns
Turn-off time when switched from			
$-I_C = 150 \text{ mA}; -I_B = 15 \text{ mA}$			
to cut-off with $+I_{BM} = 15 \text{ mA}$ (see Fig. 4)			
storage time	$t_s <$	80	ns
fall time	$t_f <$	30	ns
turn-off time ($t_s + t_f$)	$t_{off} <$	100	ns

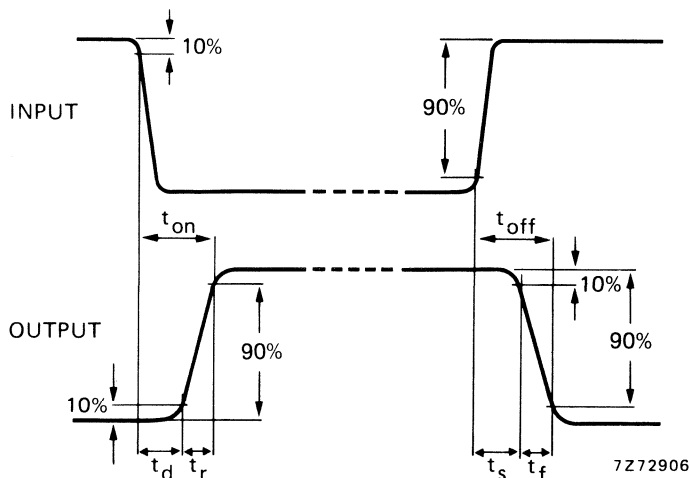

Fig. 2 Switching time waveforms.

* Measured under pulsed conditions to avoid excessive dissipation; pulse duration $t_p \leq 300 \mu\text{s}$; duty factor $\delta \leq 0,02$.

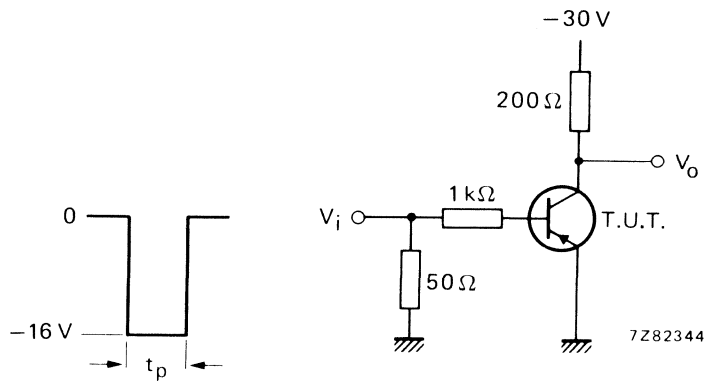

Fig. 3 Turn-on switching time test circuit.

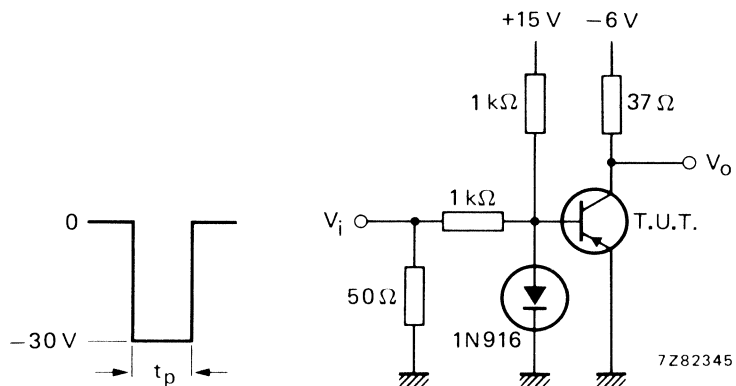

Fig. 4 Turn-off switching time test circuit.

Input pulse generator: Fig. 3 and Fig. 4	frequency	f	=	150	Hz
	pulse duration	t_p	=	200	ns
	rise time	t_r	\leq	2	ns
Output oscilloscope: Fig. 3 and Fig. 4	output impedance	Z_o	=	50	Ω
	rise time	t_r	\leq	5	ns
	input impedance	Z_i	=	10	M Ω

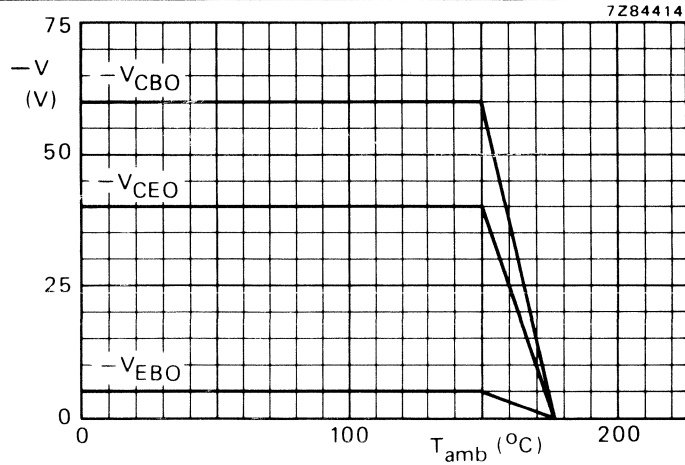

Fig. 5 Voltage derating curves BSR15.

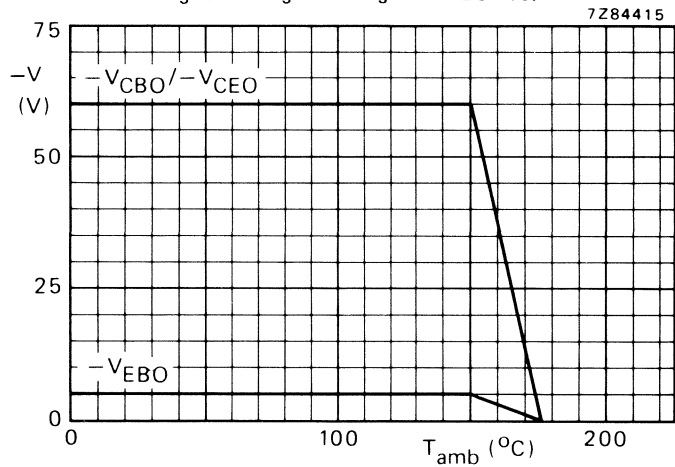

Fig. 6 Voltage derating curves BSR16.

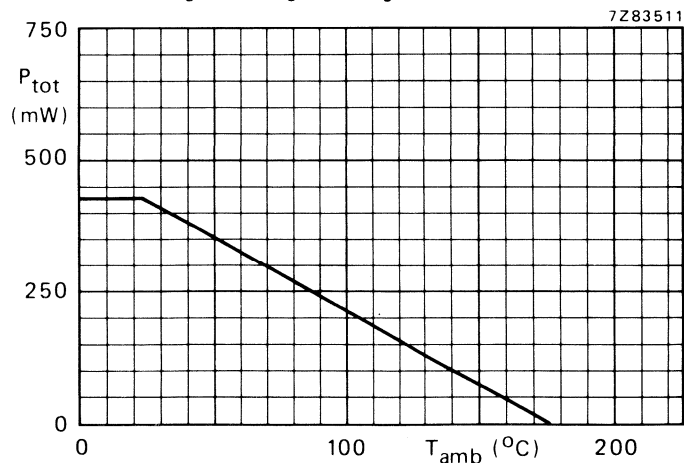

Fig. 7 Power derating curve BSR15; R/BSR16.

SILICON PLANAR EPITAXIAL TRANSISTORS

N-P-N silicon transistor in a microminiature plastic envelope intended for switching and linear applications in thick and thin-film circuits.

QUICK REFERENCE DATA

Collector-base voltage (open emitter)	V_{CBO}	max.	60 V
Collector-emitter voltage (open base)	V_{CEO}	max.	40 V
Emitter-base voltage (open collector)	V_{EBO}	max.	6 V
Collector current (d.c.)	I_C	max.	200 mA
Total power dissipation up to $T_{amb} = 25\text{ }^\circ\text{C}$	P_{tot}	max.	350 mW
Junction temperature	T_j	max.	150 $^\circ\text{C}$
D.C. current gain			
$I_C = 10\text{ mA}; V_{CE} = 1\text{ V}$	BSR17	h_{FE}	50 to 150
$I_C = 10\text{ mA}; V_{CE} = 1\text{ V}$	BSR17A	h_{FE}	100 to 300
Transition frequency at $f = 500\text{ MHz}$			
$I_C = 10\text{ mA}; V_{CE} = 20\text{ V}$	BSR17	f_T	> 250 MHz
$I_C = 10\text{ mA}; V_{CE} = 20\text{ V}$	BSR17A	f_T	> 300 MHz

MECHANICAL DATA

Fig. 1 SOT-23

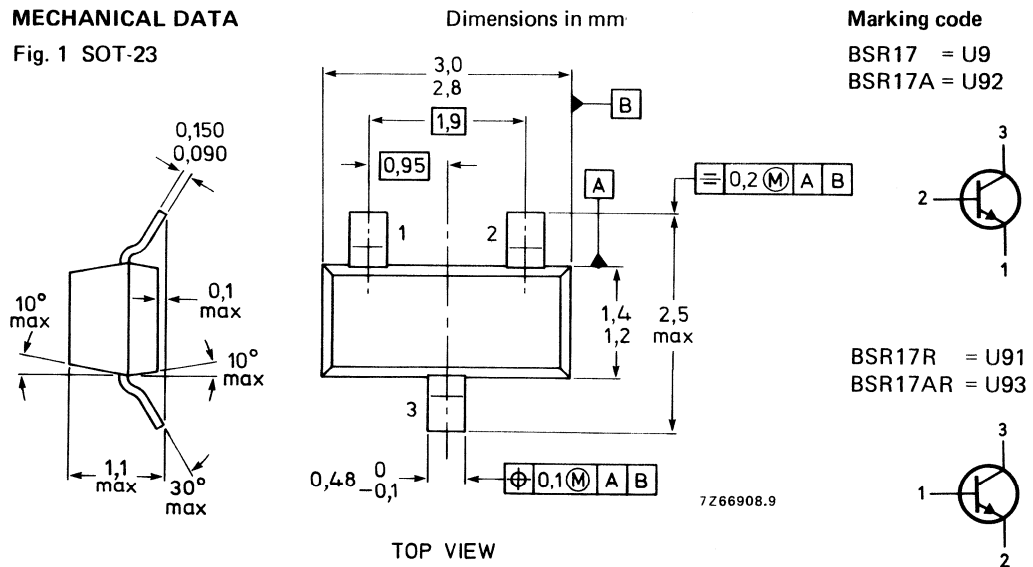

R-types are available on request.
See also *Soldering recommendations*.

RATINGS

Limiting values in accordance with the Absolute Maximum System (IEC 134)

Collector-base voltage (open emitter)	V_{CB0}	max.	60 V
Collector-emitter voltage (open base)	V_{CE0}	max.	40 V
Emitter base voltage (open collector)	V_{EB0}	max.	6 V
Collector current (d.c.)	I_C	max.	200 mA
Power dissipation up to $T_{amb} = 25\text{ }^\circ\text{C}^{**}$	P_{tot}	max.	350 mW
Storage temperature	T_{stg}		-55 to + 150 $^\circ\text{C}$
Junction temperature	T_j	max.	150 $^\circ\text{C}$

THERMAL CHARACTERISTICS*

$$T_j = P \times (R_{th\ j-t} + R_{th\ t-s} + R_{th\ s-a}) + T_{amb}$$

Thermal resistance

From junction to tab	$R_{th\ j-t}$	=	50 K/W
From tab to soldering points	$R_{th\ t-s}$	=	280 K/W
From soldering points to ambient**	$R_{th\ s-a}$	=	90 K/W

CHARACTERISTICS

$T_j = 25\text{ }^\circ\text{C}$ unless otherwise specified.

Collector cut-off current

$$I_E = 0; V_{CB} = 30\text{ V}; T_j = 150\text{ }^\circ\text{C}$$

$$V_{EB} = 3\text{ V}; V_{CE} = 30\text{ V}$$

I_{CB0}	<	5 μA
I_{CEX}	<	50 nA

Base current

with reverse biased emitter junction

$$V_{EB} = 3\text{ V}; V_{CE} = 30\text{ V}$$

I_{BEX}	<	50 nA
-----------	---	-------

Saturation voltages[▲]

$$I_C = 10\text{ mA}; I_B = 1\text{ mA}$$

V_{CEsat}	<	200 mV
V_{BEsat}		650 to 850 mV
V_{CEsat}	<	300 mV
V_{BEsat}	<	950 mV

$$I_C = 50\text{ mA}; I_B = 5\text{ mA}$$

Collector capacitance at $f = 1\text{ MHz}$

$$I_E = I_e = 0; V_{CB} = 5\text{ V}$$

C_C	<	4 pF
-------	---	------

Emitter capacitance at $f = 1\text{ MHz}$

$$I_C = I_c = 0; V_{EB} = 0,5\text{ V}$$

C_e	<	8 pF
-------	---	------

▲ Measured under pulsed conditions; pulse duration $t_p \leq 300\text{ }\mu\text{s}$; duty factor $\delta \leq 0,02$.

* See *Thermal characteristics*.

** Mounted on a ceramic substrate of 8 mm x 10 mm x 0,7 mm.

D.C. current gain*

$I_C = 0,1 \text{ mA}; V_{CE} = 1 \text{ V}$

$I_C = 1 \text{ mA}; V_{CE} = 1 \text{ V}$

$I_C = 10 \text{ mA}; V_{CE} = 1 \text{ V}$

$I_C = 50 \text{ mA}; V_{CE} = 1 \text{ V}$

$I_C = 100 \text{ mA}; V_{CE} = 1 \text{ V}$

Transition frequency at $f = 100 \text{ MHz}$

$I_C = 10 \text{ mA}; V_{CE} = 20 \text{ V}$

h-parameters (common emitter)

$I_C = 1 \text{ mA}; V_{CE} = 10 \text{ V}; f = 1 \text{ kHz}$

Input impedance

Reverse voltage transfer ratio

Small-signal current gain

Output admittance

Switching times (between 10% and 90% levels)

Turn on time switched to

$I_C = 10 \text{ mA}; I_B = 1 \text{ mA}; V_{EB} = 0,5 \text{ V}$

delay time

rise time

	BSR17	BSR17A
h_{FE}	> 20	40
h_{FE}	> 35	70
h_{FE}	> 50	100
h_{FE}	< 150	300
h_{FE}	> 30	60
h_{FE}	> 15	30
f_T	> 250	300 MHz
h_{ie}	1 to 8	1 to 10 k Ω
h_{re}	0,1 to 5	0,5 to 8 10^{-4}
h_{fe}	50 to 200	100 to 400
h_{oe}	1 to 40	1 to 40 μS
t_d	$<$	35 ns
t_r	$<$	35 ns

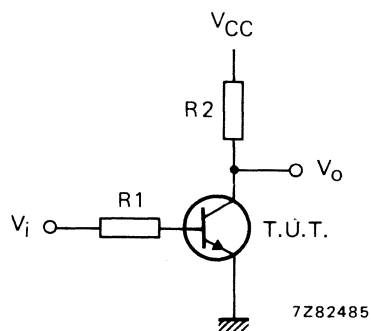
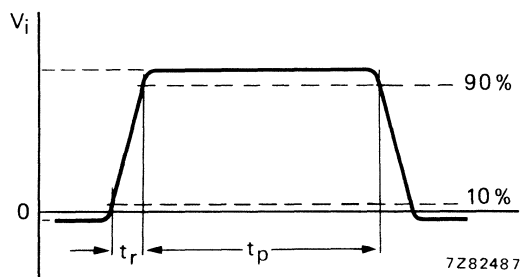

Fig. 2 Delay and rise time equivalent circuit.

$V_i = -0,5 \text{ to } +10,6 \text{ V}; V_{CC} = 3 \text{ V}; R_1 = 10 \text{ k}\Omega; R_2 = 275 \Omega;$

total shunt capacitance of test jig and connectors = $C_s \leq 4 \text{ pF}$.

Pulse generator: pulse duration 300 ns; fall time $< 1 \text{ ns}$; duty factor 2%.

Turn off time switched from
 $I_C = 10 \text{ mA}$; $I_{Bon} = -I_{Boff} = 1 \text{ mA}$
 storage time
 fall time

	BSR17	BSR17A
t_s	< 175	200 ns
t_f	< 50	50 ns

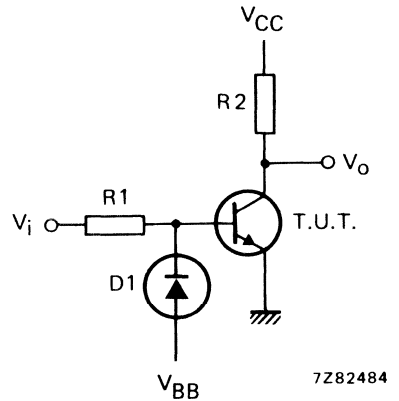
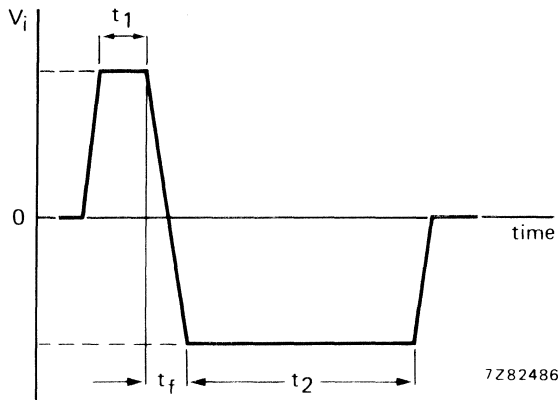

Fig. 3 Storage and fall time equivalent test circuit.

$V_i = -9,1$ to $+10,9 \text{ V}$; $V_{CC} = 3 \text{ V}$; $V_{BB} = 0 \text{ V}$ (ground); $R_1 = 10 \text{ k}\Omega$; $R_2 = 275 \Omega$;
 total shunt capacitance of test jig and connectors = $C_s \leq 4 \text{ pF}$.

Pulse generator: pulse duration $t_1 = 10$ to $500 \mu\text{s}$; fall time $t_f < 1 \text{ ns}$; duty factor $\delta = 2\%$.

SILICON LOW-POWER SWITCHING TRANSISTORS

P-N-P silicon transistor in a microminiature plastic envelope, intended for switching and linear applications in thick and thin-film circuits.

QUICK REFERENCE DATA

Collector-base voltage (open emitter)	$-V_{CBO}$	max.	40 V
Collector-emitter voltage (open base)	$-V_{CEO}$	max.	40 V
Collector current (d.c.)	$-I_C$	max.	200 mA
Total power dissipation up to $T_{amb} = 65\text{ }^\circ\text{C}$	P_{tot}	max.	250 mW
Junction temperature	T_j	max.	150 $^\circ\text{C}$
D.C. current gain			
$-I_C = 10\text{ mA}; -V_{CE} = 1\text{ V}$	BSR18	h_{FE}	50 to 150
$-I_C = 10\text{ mA}; -V_{CE} = 1\text{ V}$	BSR18A	h_{FE}	100 to 300
Transition frequency at $f = 500\text{ MHz}$			
$-I_C = 10\text{ mA}; -V_{CE} = 20\text{ V}$	BSR18	f_T	$> 200\text{ MHz}$
$-I_C = 10\text{ mA}; -V_{CE} = 20\text{ V}$	BSR18A	f_T	$> 250\text{ MHz}$

MECHANICAL DATA

Fig. 1 SOT-23:-

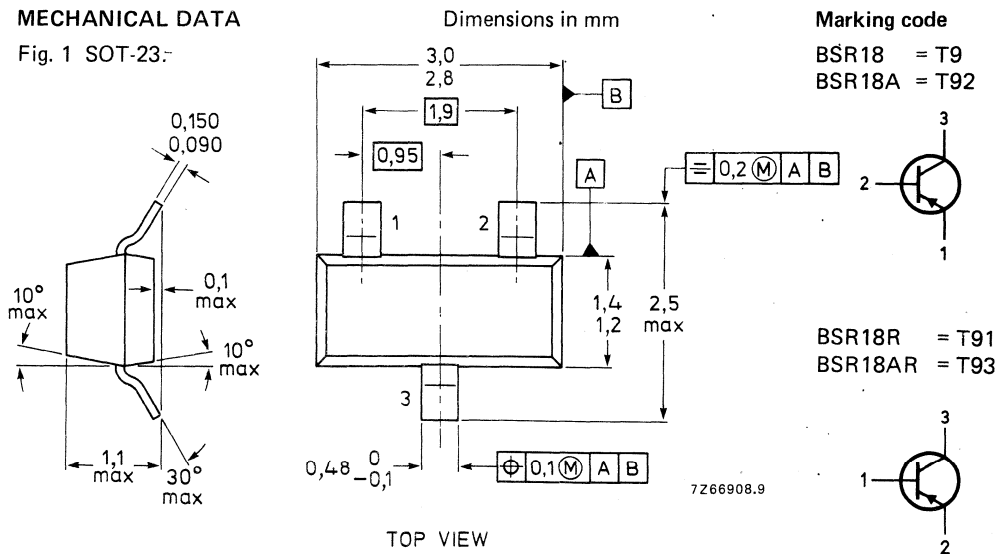

R-types are available on request.
See also *Soldering recommendations*.

RATINGS

Limiting values in accordance with the Absolute Maximum System (IEC 134)

Collector-base voltage (open emitter)	$-V_{CBO}$	max.	40 V
Collector-emitter voltage (open base)	$-V_{CEO}$	max.	40 V
Emitter base voltage (open collector)	$-V_{EBO}$	max.	5 V
Collector current (d.c.)	$-I_C$	max.	200 mA
Total power dissipation up to $T_{amb} \leq 65^\circ\text{C}$	P_{tot}	max.	200 mW
Storage temperature	T_{stg}		-55 to $+150^\circ\text{C}$
Junction temperature	T_j	max.	150°C

THERMAL CHARACTERISTICS*

$$T_j = P \times (R_{th\ j-t} + R_{th\ t-s} + R_{th\ s-a}) + T_{amb}$$

Thermal resistance

From junction to tab	$R_{th\ j-t}$	=	50 K/W
From tab to soldering points	$R_{th\ t-s}$	=	280 K/W
From soldering points to ambient**	$R_{th\ s-a}$	=	90 K/W

CHARACTERISTICS

$T_{amb} = 25^\circ\text{C}$ unless otherwise specified

Collector cut-off current

$$I_E = 0; -V_{CB} = 30\text{ V} \quad -I_{CBO} < 50\text{ nA}$$

Emitter cut-off current

$$I_C = 0; -V_{EB} = 3\text{ V} \quad -I_{EBO} < 50\text{ nA}$$

Saturation voltages [▲]

$$-I_C = 10\text{ mA}; -I_B = 1\text{ mA} \quad \begin{array}{l} -V_{CEsat} < 250\text{ mV} \\ -V_{BEsat} < 650\text{ to }850\text{ mV} \end{array}$$

$$-I_C = 50\text{ mA}; -I_B = 5\text{ mA} \quad \begin{array}{l} -V_{CEsat} < 400\text{ mV} \\ -V_{BEsat} < 950\text{ mV} \end{array}$$

Collector capacitance at $f = 100\text{ kHz}$

$$I_E = I_e = 0; -V_{CB} = 5\text{ V} \quad C_C < 4,5\text{ pF}$$

Emitter capacitance at $f = 100\text{ kHz}$

$$I_C = I_c = 0; -V_{EB} = 0,5\text{ V} \quad C_e < 10\text{ pF}$$

* See *Thermal characteristics*.

** Mounted on a ceramic substrate of 8 mm x 10 mm x 0,7 mm.

▲ Measured under pulse conditions; $t_p = 300\text{ }\mu\text{s}$; $\delta = 0,01$.

D.C. current gain*

- I_C = 0,1 mA; -V_{CE} = 1 V
- I_C = 1,0 mA; -V_{CE} = 1 V
- I_C = 10 mA; -V_{CE} = 1 V
- I_C = 50 mA; -V_{CE} = 1 V
- I_C = 100 mA; -V_{CE} = 1 V

Transition frequency at f = 100 MHz

- I_C = 10 mA; -V_{CE} = 20 V

Noise figure at R_S = 1 kΩ

- I_C = 100 μA; -V_{CE} = 5 V
- f = 10 to 15 700 Hz

h parameters (common emitter) at f = 1 kHz

- I_C = 1 mA; -V_{CE} = 10 V

- input impedance
- reverse voltage transfer ratio
- small signal current gain
- output admittance

Switching times (between 10% and 90% levels)

- I_C = 10 mA; -I_{Bon} = +I_{Boff} = 1 mA
- delay time
- rise time

	BSR18	BSR18A
h _{FE}	> 30	60
h _{FE}	> 40	80
h _{FE}	50 to 150	100 to 300
h _{FE}	> 30	60
h _{FE}	> 15	30
f _T	> 200	250 MHz
F	< 5	4 dB
h _{ie}	0,5 to 8	2 to 12 kΩ
h _{re}	0,1 to 5.10 ⁻⁴	1 to 10.10 ⁻⁴
h _{fe}	50 to 200	100 to 400
h _{oe}	1 to 40	3 to 60 μS
t _d	<	35 ns
t _r	<	35 ns

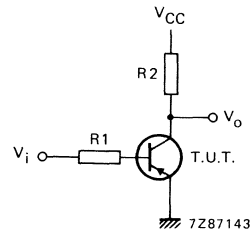
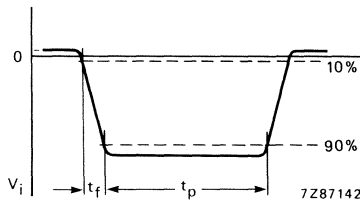

Fig. 2 Waveform and test circuit delay and rise time.
 V_i = +0,5 to -10,6 V; -V_{CC} = 3 V; R₁ = 10 kΩ; R₂ = 275 Ω.
 Total shunt capacitance of test jig and connectors = C_s ≤ 4 pF.
 Pulse generator: pulse duration 300 ns; fall time < 1 ns; duty factor 2%.

BSR18 BSR18A

Switching times (between 10% and 90% levels)
 $-I_C = 10 \text{ mA}$, $-I_{\text{Bon}} = I_{\text{Boff}} = 1 \text{ mA}$
 storage time
 fall time

	BSR18	BSR18A
t_s	< 200	225 ns
t_r	< 60	75 ns

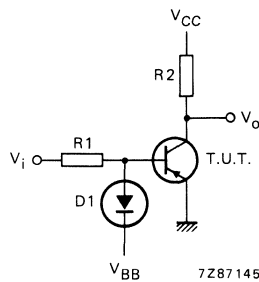
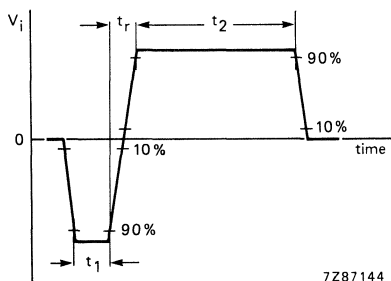

Fig. 3 Waveform and test circuit fall and storage time.
 $V_i = -9,1 \text{ to } +10,9 \text{ V}$; $V_{CC} = 3 \text{ V}$; $V_{BB} = 0 \text{ V}$ (ground); $R_1 = 10 \text{ k}\Omega$; $R_2 = 275 \Omega$; $D_1 = 1\text{N}916$.
 Total shunt capacitance of test jig and connectors = $C_s \leq 4 \text{ pF}$.
 Pulse generator: pulse duration $t_1 = 10 \text{ to } 500 \mu\text{s}$; rise time $t_r < 1 \text{ ns}$; duty factor $\delta = 2\%$.

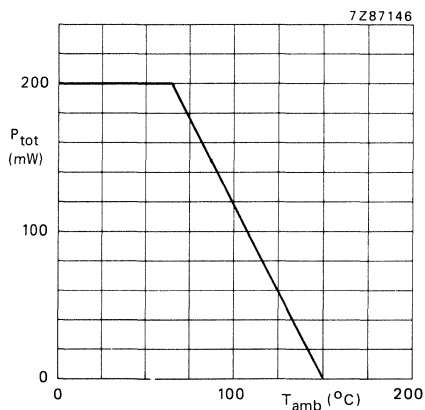

Fig. 4 Power derating curve.

SILICON N-P-N HIGH-VOLTAGE TRANSISTORS

N-P-N high-voltage small-signal transistors for general purposes and especially telephony applications and encapsulated in a SOT-23 envelope.

P-N-P complements are BSR20 and BSR20A.

QUICK REFERENCE DATA

			BSR19	BSR19A
Collector-base voltage (open emitter)	V_{CBO}	max.	160	180 V
Collector-emitter voltage (open base)	V_{CEO}	max.	140	160 V
Collector current	I_C	max.	600	600 mA
Total power dissipation up to $T_{amb} = 25\text{ }^\circ\text{C}$	P_{tot}	max.	350	350 mW
Junction temperature	T_j	max.	150	150 $^\circ\text{C}$
Collector-emitter saturation voltage $I_C = 50\text{ mA}; I_B = 5\text{ mA}$	V_{CEsat}	max.	0,25	0,20 V
D.C. current gain $I_C = 10\text{ mA}; V_{CE} = 5\text{ V}$	h_{FE}	min.	60	80

MECHANICAL DATA

Fig. 1 SOT-23.

Dimensions in mm

Marking code

BSR19 = U35

BSR19A = U36

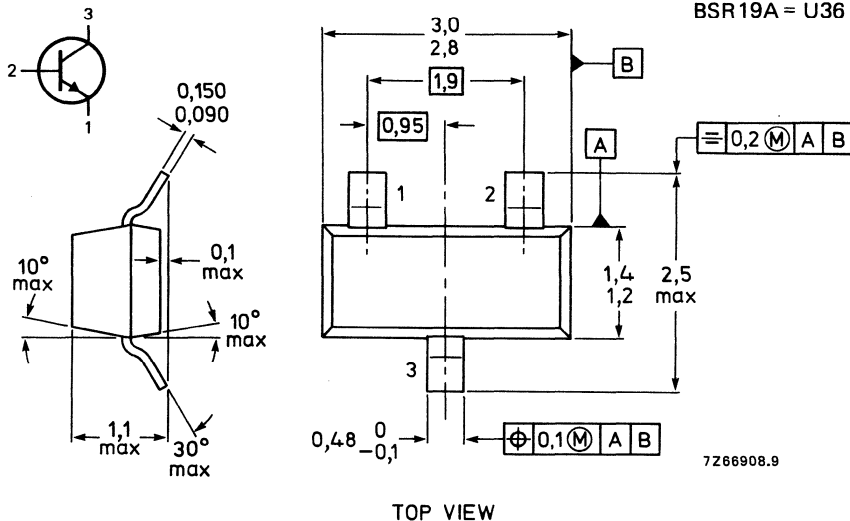

RATINGS

Limiting values in accordance with the Absolute Maximum System (IEC 134)

			BSR19	BSR19A
Collector-base voltage (open emitter)	V_{CBO}	max.	160	180 V
Collector-emitter voltage (open base)	V_{CEO}	max.	140	160 V
Emitter-base voltage (open collector)	V_{EBO}	max.	6	V
Collector current	I_C	max.	600	mA
Total power dissipation up to $T_{amb} = 25\text{ }^\circ\text{C}$	P_{tot}	max.	350	mW
Junction temperature	T_j	max.	150	$^\circ\text{C}$
Storage temperature	T_{stg}		-65 to +150	$^\circ\text{C}$
Thermal resistance*	$R_{th\ j-t}$		30	K/W
	$R_{th\ t-s}$		260	K/W
	$R_{th\ s-a}$		60	K/W

CHARACTERISTICS

$T_{amb} = 25\text{ }^\circ\text{C}$ unless otherwise specified

			BSR19	BSR19A
Collector cut-off current				
$I_E = 0; V_{CB} = 100\text{ V}$	I_{CBO}	max.	100	nA
$I_E = 0; V_{CB} = 120\text{ V}$	I_{CBO}	max.		50 nA
$I_E = 0; V_{CB} = 100\text{ V}; T_{amb} = 100\text{ }^\circ\text{C}$	I_{CBO}	max.	100	μA
$I_E = 0; V_{CB} = 120\text{ V}; T_{amb} = 100\text{ }^\circ\text{C}$	I_{CBO}	max.		50 μA
Emitter cut-off current				
$I_C = 0; V_{EB} = 4,0\text{ V}$	I_{EBO}	max.	50	50 nA
Breakdown voltages				
$I_C = 1,0\text{ mA}; I_B = 0$	$V_{(BR)CEO}$	min.	140	160 V
$I_C = 100\text{ } \mu\text{A}; I_E = 0$	$V_{(BR)CBO}$	min.	160	180 V
$I_C = 0; I_E = 10\text{ } \mu\text{A}$	$V_{(BR)EBO}$	min.	6,0	6,0 V
Saturation voltages				
$I_C = 10\text{ mA}; I_B = 1,0\text{ mA}$	V_{CEsat}	max.	0,15	0,15 V
	V_{BEsat}	max.	1,0	1,0 V
$I_C = 50\text{ mA}; I_B = 5,0\text{ mA}$	V_{CEsat}	max.	0,25	0,20 V
	V_{BEsat}	max.	1,2	1,0 V
D.C. current gain				
$I_C = 1,0\text{ mA}; V_{CE} = 5\text{ V}$	h_{FE}	min.	60	80
$I_C = 10\text{ mA}; V_{CE} = 5\text{ V}$	h_{FE}	min.	60	80
$I_C = 50\text{ mA}; V_{CE} = 5\text{ V}$	h_{FE}	max.	250	250
	h_{FE}	min.	20	30
Small-signal current gain				
$I_C = 1,0\text{ mA}; V_{CE} = 10\text{ V}; f = 1\text{ kHz}$	h_{fe}	min.	50	50
		max.	200	200
Output capacitance at $f = 1\text{ MHz}$				
$I_E = 0; V_{CB} = 10\text{ V}$	C_o	max.	6	6 pF

* Substrate size 15 mm x 15 mm x 0,7 mm.

			BSR19	BSR19A
Input capacitance at $f = 1$ MHz $I_C = 0$; $V_{EB} = 0,5$ V	C_i	max.	30	30 pF
Transition frequency at $f = 100$ MHz $I_C = 10$ mA; $V_{CE} = 10$ V	f_T	min.	100	100 MHz
		max.	300	300 MHz
Noise figure at $R_S = 1$ k Ω $I_C = 250$ μ A; $V_{CE} = 5$ V; $f = 10$ Hz to 15,7 kHz	F	max.	10	8 dB

SILICON P-N-P HIGH-VOLTAGE TRANSISTORS

P-N-P high-voltage small-signal transistors for general purposes and especially in telephony applications and encapsulated in a SOT-23 envelope.

N-P-N complements are BSR19 and BSR19A.

QUICK REFERENCE DATA

		BSR20	BSR20A
Collector-base voltage (open emitter)	$-V_{CBO}$ max.	130	160 V
Collector-emitter voltage (open base)	$-V_{CEO}$ max.	120	150 V
Collector current	$-I_C$ max.	600	600 mA
Total power dissipation up to $T_{amb} = 25\text{ }^\circ\text{C}$	P_{tot} max.	350	350 mW
Junction temperature	T_j max.	150	150 $^\circ\text{C}$
Collector-emitter saturation voltage $I_C = 50\text{ mA}; I_B = 5\text{ mA}$	V_{CEsat} max.	0,5	0,5 V
D.C. current gain $I_C = 10\text{ mA}; V_{CE} = -5\text{ V}$	h_{FE} min.	40	60

MECHANICAL DATA

Fig. 1 SOT-23.

Dimensions in mm

Marking code

BSR20 = T35

BSR20A = T36

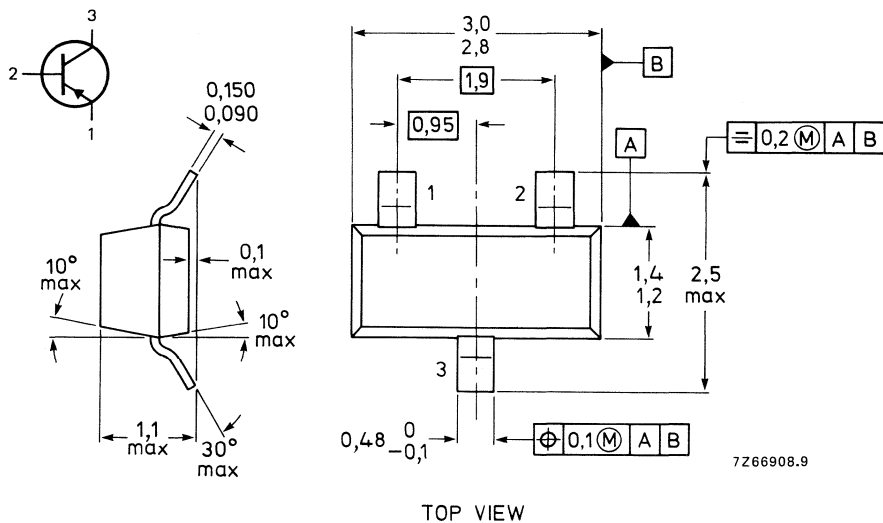

7266908.9

RATINGS

Limiting values in accordance with the Absolute Maximum System (IEC 134)

			BSR20	BSR20A
Collector-base voltage (open emitter)	$-V_{CB0}$	max.	130	160 V
Collector-emitter voltage (open base)	$-V_{CEO}$	max.	120	150 V
Emitter-base voltage (open collector)	$-V_{EBO}$	max.	5	V
Collector current	$-I_C$	max.	600	mA
Total power dissipation up to $T_{amb} = 25\text{ }^\circ\text{C}$	P_{tot}	max.	350	mW
Junction temperature	T_j	max.	150	$^\circ\text{C}$
Storage temperature	T_{stg}		-65 to +150	$^\circ\text{C}$
Thermal resistance*	$R_{th\ j-t}$		30	K/W
	$R_{th\ t-s}$		260	K/W
	$R_{th\ s-a}$		60	K/W

CHARACTERISTICS

$T_{amb} = 25\text{ }^\circ\text{C}$ unless otherwise specified

			BSR20	BSR20A
Collector cut-off current				
$I_E = 0; -V_{CB} = 100\text{ V}$	$-I_{CBO}$	max.	100	nA
$I_E = 0; -V_{CB} = 120\text{ V}$	$-I_{CBO}$	max.		50 nA
$I_E = 0; -V_{CB} = 100\text{ V}; T_{amb} = 100\text{ }^\circ\text{C}$	$-I_{CBO}$	max.	100	μA
$I_E = 0; -V_{CB} = 120\text{ V}; T_{amb} = 100\text{ }^\circ\text{C}$	$-I_{CBO}$	max.		50 μA
Emitter cut-off current				
$I_C = 0; -V_{EB} = 4,0\text{ V}$	$-I_{EBO}$	max.	50	50 nA
Breakdown voltages				
$I_C = 1,0\text{ mA}; I_B = 0$	$-V_{(BR)CEO}$	min.	120	150 V
$I_C = 100\text{ }\mu\text{A}; I_E = 0$	$-V_{(BR)CBO}$	min.	130	160 V
$I_C = 0; I_E = 10\text{ }\mu\text{A}$	$-V_{(BR)EBO}$	min.	5,0	5,0 V
Saturation voltages				
$-I_C = 10\text{ mA}; -I_B = 1,0\text{ mA}$	$-V_{CEsat}$	max.	0,2	0,2 V
	$-V_{BEsat}$	max.	1,0	1,0 V
$-I_C = 50\text{ mA}; -I_B = 5,0\text{ mA}$	$-V_{CEsat}$	max.	0,5	0,5 V
	$-V_{BEsat}$	max.	1,0	1,0 V
D.C. current gain				
$I_C = 1,0\text{ mA}; -V_{CE} = 5\text{ V}$	h_{FE}	min.	30	50
			40	60
$I_C = 10\text{ mA}; -V_{CE} = 5\text{ V}$	h_{FE}	max.	180	240
			40	50
$I_C = 50\text{ mA}; -V_{CE} = 5\text{ V}$	h_{FE}	min.	40	50
Small-signal current gain				
$I_C = 1,0\text{ mA}; -V_{CE} = 10\text{ V}; f = 1\text{ kHz}$	h_{fe}	min.	30	40
		max.	200	200
Output capacitance at $f = 1\text{ MHz}$				
$I_E = 0; -V_{CB} = 10\text{ V}$	C_o	max.	6	6 pF

* Substrate size 15 mm x 15 mm x 0,7 mm.

			BSR20	BSR20A
Transition frequency at $f = 100$ MHz $-I_C = 10$ mA; $-V_{CE} = 10$ V	f_T	min.	100	100 MHz
		max.	400	300 MHz
Noise figure at $R_S = 1$ k Ω $I_C = 250$ μ A; $-V_{CE} = 5$ V; $f = 10$ Hz to 15,7 kHz	F	max.	8	8 dB

RATINGS

Limiting values in accordance with the Absolute Maximum System (IEC 134)

		BSR30	BSR31	BSR32	BSR33
Collector-base voltage (open emitter)	$-V_{CBO}$ max.	70	70	90	90 V
Collector-emitter voltage (open base)	$-V_{CEO}$ max.	60	60	80	80 V
Emitter-base voltage (open collector)	$-V_{EBO}$ max.	5	5	5	5 V
Collector current (d.c.)	$-I_C$ max.			1	A
Base current (d.c.)	$-I_B$ max.			0,1	A
Total power dissipation up to $T_{amb} = 25\text{ }^{\circ}\text{C}$ mounted on a ceramic substrate area = 2,5 cm ² ; thickness = 0,7 mm					
	P_{tot} max.			1	W
Storage temperature	T_{stg}		-65 to +150		$^{\circ}\text{C}$
Junction temperature	T_j max.		150		$^{\circ}\text{C}$
THERMAL RESISTANCE					
From junction to collector tab	$R_{th\ j-tab}$ =			10	K/W
From junction to ambient in free air mounted on a ceramic substrate area = 2,5 cm ² ; thickness = 0,7 mm	$R_{th\ j-a}$ =			125	K/W

CHARACTERISTICS $T_{amb} = 25\text{ }^{\circ}\text{C}$ unless otherwise specified**Collector cut-off current**

$I_E = 0; -V_{CB} = 60\text{ V}$	$-I_{CBO}$	<	100	nA
$I_E = 0; -V_{CB} = 60\text{ V}; T_j = 150\text{ }^{\circ}\text{C}$	$-I_{CBO}$	<	50	μA

Breakdown voltages

			BSR30	BSR31	BSR32	BSR33	
$I_B = 0; -I_C = 10\text{ mA}$	$-V_{(BR)CEO}$	>	60	60	80	80	V
$V_{BE} = 0; -I_C = 10\text{ }\mu\text{A}$	$-V_{(BR)CES}$	>	70	70	90	90	V
$I_C = 0; -I_E = 10\text{ }\mu\text{A}$	$-V_{(BR)EBO}$	>	5	5	5	5	V

Saturation voltages *

$-I_C = 150\text{ mA}; -I_B = 15\text{ mA}$	$-V_{CEsat}$	<	0,25	0,25	0,25	0,25	V
	$-V_{BEsat}$	<	1,0	1,0	1,0	1,0	V
$-I_C = 500\text{ mA}; -I_B = 50\text{ mA}$	$-V_{CEsat}$	<	0,5	0,5	0,5	0,5	V
	$-V_{BEsat}$	<	1,2	1,2	1,2	1,2	V

D.C. current gain *

$-I_C = 100\text{ }\mu\text{A}; V_{CE} = 5\text{ V}$	h_{FE}	>	10	30	10	30
$-I_C = 100\text{ mA}; V_{CE} = 5\text{ V}$	h_{FE}	>	40	100	40	100
	h_{FE}	<	120	300	120	300
$-I_C = 500\text{ mA}; V_{CE} = 5\text{ V}$	h_{FE}	>	30	50	30	50

Transition frequency at $f = 35\text{ MHz}$

$-I_C = 50\text{ mA}; -V_{CE} = 10\text{ V}$	f_T	>	100	MHz
--	-------	---	-----	-----

Collector capacitance at $f = 1\text{ MHz}$

$I_E = I_e = 0; -V_{CB} = 10\text{ V}$	C_c	<	20	pF
--	-------	---	----	----

Emitter capacitance at $f = 1\text{ MHz}$

$I_C = I_c = 0; -V_{EB} = 0,5\text{ V}$	C_e	<	120	pF
---	-------	---	-----	----

Switching times see next page.

* Measured under pulse conditions: $t_p = 300\text{ }\mu\text{s}; \delta < 0,01$.

CHARACTERISTICS (continued)

$T_{amb} = 25\text{ }^{\circ}\text{C}$

Switching times

$-I_{Con} = 100\text{ mA}; -I_{Boff} = +I_{Boff} = 5\text{ mA}$

Turn-on time

$t_{on} < 500\text{ ns}$

Turn-off time

$t_{off} < 650\text{ ns}$

Test circuit

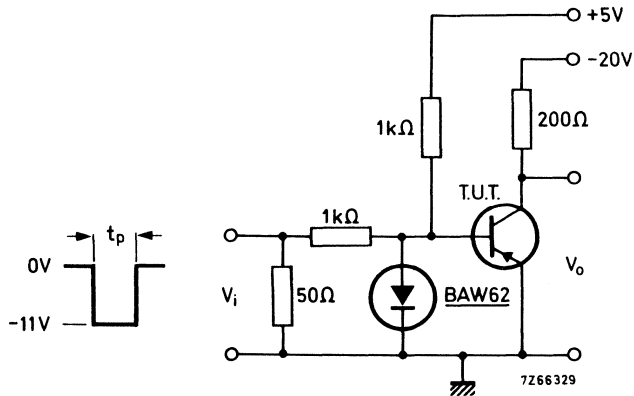

Pulse generator:

Pulse duration $t_p = 10\text{ }\mu\text{s}$
 Rise time $t_r \leq 15\text{ ns}$
 Fall time $t_f \leq 15\text{ ns}$
 Source impedance $Z_S = 50\text{ }\Omega$

Oscilloscope:

Rise time $t_r \leq 15\text{ ns}$
 Input impedance $Z_I \geq 100\text{ k}\Omega$

SILICON PLANAR EPITAXIAL TRANSISTORS

N-P-N transistors in miniature plastic envelopes intended for application in thick and thin-film circuits. They are intended for use in telephony and general industrial applications.

QUICK REFERENCE DATA

		BSR40	BSR41	BSR42	BSR43
Collector-base voltage (open emitter)	V_{CBO} max.	70	70	90	90 V
Collector-emitter voltage (open base)	V_{CEO} max.	60	60	80	80 V
Collector current (d.c.)	I_C max.	1	1	1	1 A
Total power dissipation up to $T_{amb} = 25\text{ }^\circ\text{C}$	P_{tot} max.	1	1	1	1 W
Junction temperature	T_j max.	150	150	150	150 $^\circ\text{C}$
D.C. current gain	h_{FE}	> 40	100	40	100
$I_C = 100\text{ mA}; V_{CE} = 5\text{ V}$		< 120	300	120	300
Transition frequency at $f = 35\text{ MHz}$	f_T	> 100	100	100	100 MHz
$I_C = 50\text{ mA}; V_{CE} = 10\text{ V}$					

MECHANICAL DATA

Dimensions in mm

Mark

Fig. 1 SOT-89.

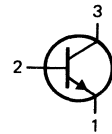
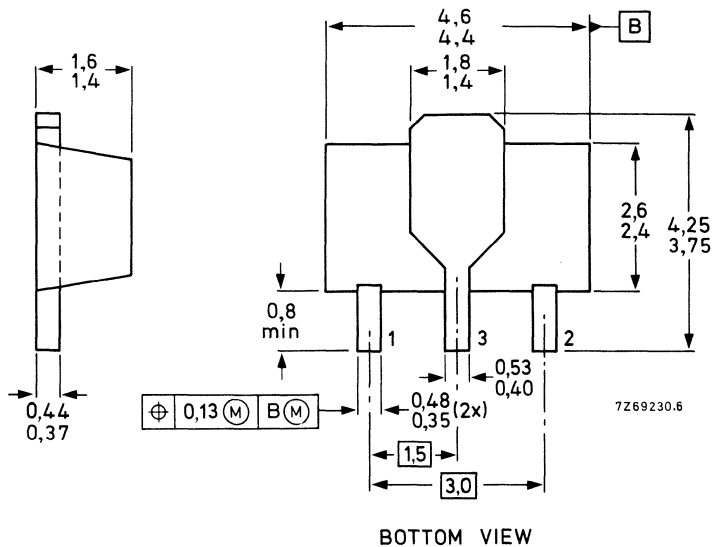

RATINGS

Limiting values in accordance with the Absolute Maximum System (IEC 134)

		BSR40	BSR41	BSR42	BSR43
Collector-base voltage (open emitter)	V_{CBO} max.	70	70	90	90 V
Collector-emitter voltage (open base)	V_{CEO} max.	60	60	80	80 V
Emitter-base voltage (open collector)	V_{EBO} max.	5	5	5	5 V
Collector current (d.c.)	I_C max.			1	A
Base current (d.c.)	I_B max.			0,1	A
Total power dissipation up to $T_{amb} = 25\text{ }^{\circ}\text{C}$ mounted on a ceramic substrate area = 2,5 cm ² ; thickness = 0,7 mm					
	P_{tot} max.			1	W
Storage temperature	T_{stg}		-65 to +150		$^{\circ}\text{C}$
Junction temperature	T_j max.		150		$^{\circ}\text{C}$
THERMAL RESISTANCE					
From junction to collector tab	$R_{th\ j-tab}$ =			10	K/W
From junction to ambient in free air mounted on a ceramic substrate area = 2,5 cm ² ; thickness = 0,7 m	$R_{th\ j-a}$ =			125	K/W

CHARACTERISTICS

$T_{amb} = 25\text{ }^{\circ}\text{C}$ unless otherwise specified

Collector cut-off current

$I_E = 0; V_{CB} = 60\text{ V}$	I_{CBO}	<	100	nA
$I_E = 0; V_{CB} = 60\text{ V}; T_j = 150\text{ }^{\circ}\text{C}$	I_{CBO}	<	50	μA

Breakdown voltages

			BSR40	BSR41	BSR42	BSR43	
$I_B = 0; I_C = 10\text{ mA}$	$V_{(BR)CEO}$	>	60	60	80	80	V
$V_{BE} = 0; I_C = 10\text{ }\mu\text{A}$	$V_{(BR)CES}$	>	70	70	90	90	V
$I_C = 0; I_E = 10\text{ }\mu\text{A}$	$V_{(BR)EBO}$	>	5	5	5	5	V

Saturation voltages *

$I_C = 150\text{ mA}; I_B = 15\text{ mA}$	V_{CEsat}	<	0,25	0,25	0,25	0,25	V
	V_{BEsat}	<	1,0	1,0	1,0	1,0	V
$I_C = 500\text{ mA}; I_B = 50\text{ mA}$	V_{CEsat}	<	0,5	0,5	0,5	0,5	V
	V_{BEsat}	<	1,2	1,2	1,2	1,2	V

D.C. current gain *

$I_C = 100\text{ }\mu\text{A}; V_{CE} = 5\text{ V}$	h_{FE}	>	10	30	10	30
$I_C = 100\text{ mA}; V_{CE} = 5\text{ V}$	h_{FE}	>	40	100	40	100
	h_{FE}	<	120	300	120	300
$I_C = 500\text{ mA}; V_{CE} = 5\text{ V}$	h_{FE}	>	30	50	30	50

Transition frequency at $f = 35\text{ MHz}$

$I_C = 50\text{ mA}; V_{CE} = 10\text{ V}$	f_T	>	100	MHz
--	-------	---	-----	-----

Collector capacitance at $f = 1\text{ MHz}$

$I_E = I_e = 0; V_{CB} = 10\text{ V}$	C_c	<	12	pF
---------------------------------------	-------	---	----	----

Emitter capacitance at $f = 1\text{ MHz}$

$I_C = I_c = 0; V_{EB} = 0,5\text{ V}$	C_e	<	90	pF
--	-------	---	----	----

Switching times see next page.

* Measured under pulse conditions: $t_p = 300\text{ }\mu\text{s}; \delta < 0,01$.

CHARACTERISTICS (continued)

$T_{amb} = 25\text{ }^{\circ}\text{C}$

Switching times

$I_{Con} = 100\text{ mA}; I_{Bon} = -I_{Boff} = 5\text{ mA}$

Turn-on time

$t_{on} < 250\text{ ns}$

Turn-off time

$t_{off} < 1000\text{ ns}$

Test circuit

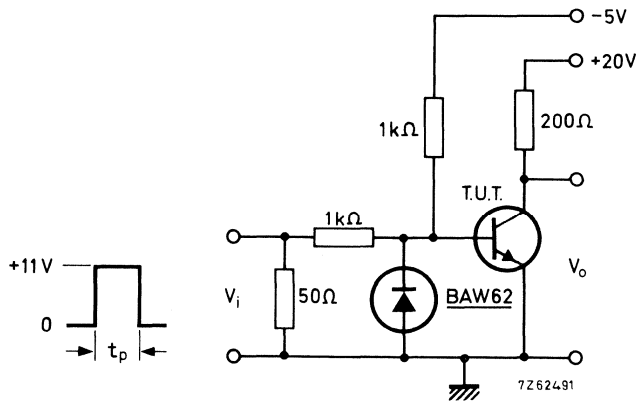

Pulse generator:

Pulse duration $t_p = 10\text{ }\mu\text{s}$
 Rise time $t_r \leq 15\text{ ns}$
 Fall time $t_f \leq 15\text{ ns}$
 Source impedance $Z_S = 50\text{ }\Omega$

Oscilloscope:

Rise time $t_r \leq 15\text{ ns}$
 Input impedance $Z_I \geq 100\text{ k}\Omega$

N-CHANNEL FETS

Silicon n-channel depletion type junction field-effect transistors in a plastic microminiature envelope intended for application in thick and thin-film circuits. The transistors are intended for low-power, chopper or switching applications in industrial service.

QUICK REFERENCE DATA

			BSR56	BSR57	BSR58	
Drain-source voltage	$\pm V_{DS}$	max.	40	40	40 V	
Total power dissipation up to $T_{amb} = 65^\circ\text{C}$	P_{tot}	max.	250	250	250 mW	
Drain current $V_{DS} = 15\text{ V}; V_{GS} = 0$	I_{DSS}	>	50	20	8 mA	
		<	—	100	80 mA	
Gate-source cut-off voltage $V_{DS} = 15\text{ V}; I_D = 0,5\text{ nA}$	$-V_{(P)GS}$	>	4	2	0,8 V	
		<	10	6	4 V	
Drain-source resistance (on) at $f = 1\text{ kHz}$ $I_D = 0; V_{GS} = 0$	$r_{ds\ on}$	<	25	40	60 Ω	
Feedback capacitance at $f = 1\text{ MHz}$ $-V_{GS} = 10\text{ V}; V_{DS} = 0$	C_{rs}	<	5	5	5 pF	
Turn-off time $V_{DD} = 10\text{ V}; V_{GS} = 0$	t_{off}	$I_D = 20\text{ mA}; -V_{GSM} = 10\text{ V}$	<	25	—	— ns
		$I_D = 10\text{ mA}; -V_{GSM} = 6\text{ V}$	<	—	50	— ns
		$I_D = 5\text{ mA}; -V_{GSM} = 4\text{ V}$	<	—	—	100 ns

MECHANICAL DATA

Fig. 1 SOT-23.

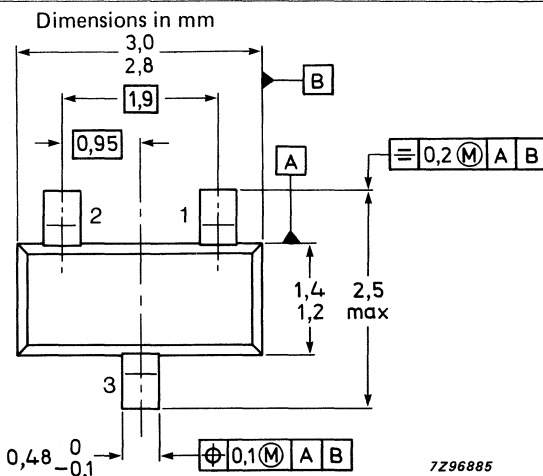
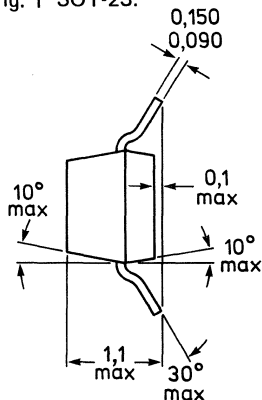

Marking code

BSR56 = M4
BSR57 = M5
BSR58 = M6

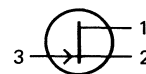

7296885

See also *Soldering Recommendations*. TOP VIEW

RATINGS

Limiting values in accordance with the Absolute Maximum System (IEC 134)

Drain-source voltage (See Fig. 4)	$\pm V_{DS}$	max.	40 V
Drain-gate voltage (See Fig. 4)	V_{DGO}	max.	40 V
Gate-source voltage (See Fig. 4)	$-V_{GSO}$	max.	40 V
Forward gate current	I_{GF}	max.	50 mA
Total power dissipation up to $T_{amb} = 65\text{ }^{\circ}\text{C}$	P_{tot}	max.	250 mW
Storage temperature range	T_{stg}		$-55\text{ to }+175\text{ }^{\circ}\text{C}$
Junction temperature	T_j	max.	175 $^{\circ}\text{C}$

THERMAL CHARACTERISTICS*

$$T_j = P (R_{th\ j-t} + R_{th\ t-s} + R_{th\ s-a}) + T_{amb}$$

Thermal resistance

From junction to tab	$R_{th\ j-t}$	=	60 K/W
From tab to soldering points	$R_{th\ t-s}$	=	280 K/W
From soldering points to ambient**	$R_{th\ s-a}$	=	90 K/W

CHARACTERISTICS

$T_{amb} = 25\text{ }^{\circ}\text{C}$ unless otherwise specified

Gate-source cut-off current $V_{DS} = 0\text{ V}; -V_{GS} = 20\text{ V}$	$-I_{GSS}$	<	1	nA
Drain cut-off current $V_{DS} = 15\text{ V}; -V_{GS} = 10\text{ V}$	I_{DSX}	<	1	nA

		BSR56	BSR57	BSR58
Drain current \blacktriangle $V_{DS} = 15\text{ V}; V_{GS} = 0$	I_{DSS}	> 50	20	8 mA
		< —	100	80 mA
Gate-source breakdown voltage $-I_G = 1\text{ }\mu\text{A}; V_{DS} = 0$	$-V_{(BR)GSS}$	> 40	40	40 V
Gate-source cut-off voltage $I_D = 0,5\text{ nA}; V_{DS} = 15\text{ V}$	$-V_{(P)GS}$	> 4	2	0,8 V
		< 10	6	4 V
Drain-source voltage (on) $I_D = 20\text{ mA}; V_{GS} = 0$ $I_D = 10\text{ mA}; V_{GS} = 0$ $I_D = 5\text{ mA}; V_{GS} = 0$	V_{DSon}	< 750	—	— mV
	V_{DSon}	< —	500	— mV
	V_{DSon}	< —	—	400 mV
Drain-source resistance (on) at $f = 1\text{ kHz}$ $I_D = 0; V_{GS} = 0$	$r_{ds\ on}$	< 25	40	60 Ω

* See *Thermal characteristics*.

** Mounted on a ceramic substrate of 8 mm x 10 mm x 0,7 mm.

\blacktriangle Measured under pulsed conditions; $t_p = 100\text{ ms}; \delta \leq 0,1$.

Switching times*

$V_{DD} = 10\text{ V}; V_{GS} = 0$

Conditions I_D and $-V_{GSM}$

Delay time

Rise time

Turn-off time

			BSR56	BSR57	BSR58
I_D	=		20	10	5 mA
$-V_{GSM}$	=		10	6	4 V
Delay time	t_d	<	6	6	10 ns
Rise time	t_r	<	3	4	10 ns
Turn-off time	t_{off}	<	25	50	100 ns

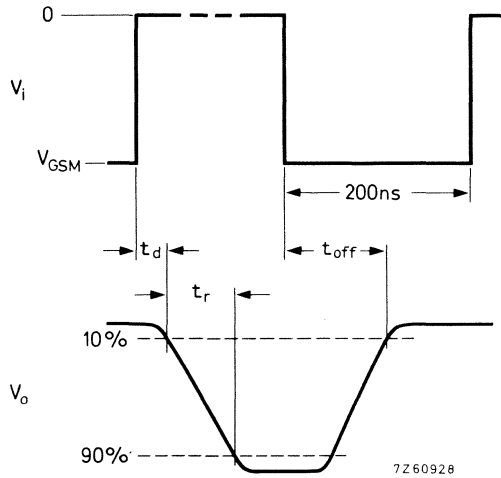

Fig. 2 Switching times waveforms.

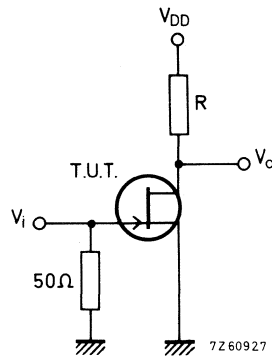

Fig. 3 Test circuit.

BSR56; $R = 464\ \Omega$
BSR57; $R = 953\ \Omega$
BSR58; $R = 1910\ \Omega$

Pulse generator

$t_r = t_f \leq 1\text{ ns}$
 $\delta = 0,02$
 $Z_o = 50\ \Omega$

Oscilloscope

$t_r \leq 0,75\text{ ns}$
 $R_i \geq 1\text{ M}\Omega$
 $C_i \leq 2,5\text{ pF}$

* Switching times measured on devices in SOT-18 envelope.

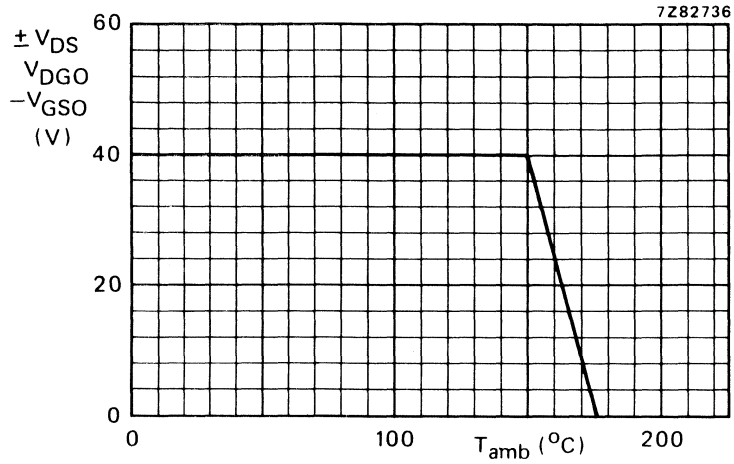

Fig. 4 Voltage derating curve.

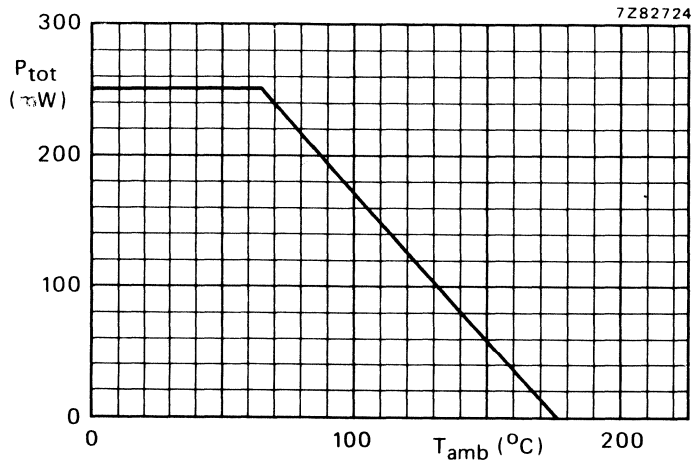

Fig. 5 Power derating curve.

HIGH VOLTAGE P-N-P TRANSISTORS

Silicon planar epitaxial transistor in a microminiature plastic envelope intended for application in thick and thin-film circuits. This transistor is intended for high voltage general purpose and switching applications.

QUICK REFERENCE DATA

Collector-base voltage (open emitter)	$-V_{CB0}$	max.	110 V
Collector-emitter voltage (open base)	$-V_{CE0}$	max.	100 V
Collector current (peak value)	$-I_{CM}$	max.	100 mA
Total power dissipation up to $T_{amb} = 25\text{ }^{\circ}\text{C}$	P_{tot}	max.	350 mW
Junction temperature	T_j	max.	175 $^{\circ}\text{C}$
D.C. current gain at $T_j = 25\text{ }^{\circ}\text{C}$ $-I_C = 25\text{ mA}; -V_{CE} = 5\text{ V}$	h_{FE}	>	30
Transition frequency at $f = 35\text{ MHz}$ $-I_C = 25\text{ mA}; -V_{CE} = 5\text{ V}$	f_T	>	50 MHz typ. 85 MHz

MECHANICAL DATA

Dimensions in mm

Marking code

Fig. 1 SOT-23.

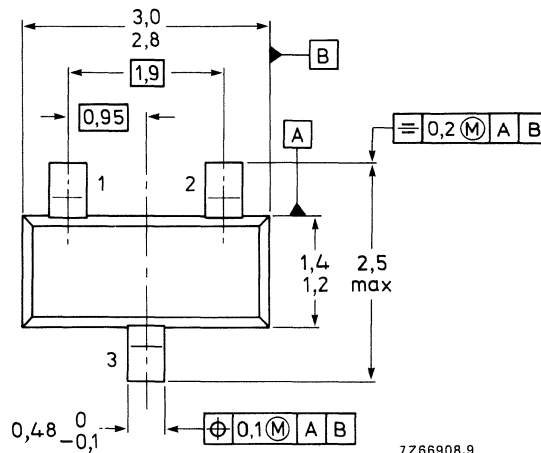
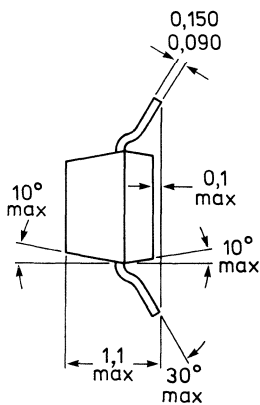

BSS63 = T3

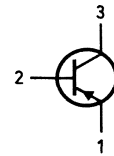

BSS63R = T6

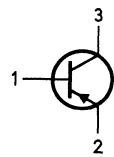

TOP VIEW

7Z66908.9

R-types are available on request

See also *Soldering recommendations*.

RATINGS

Limiting values in accordance with the Absolute Maximum System (IEC 134)

Collector-base voltage (open emitter) see Fig. 6			
-I _C = 10 μA	-V _{CB0}	max.	110 V
Collector-emitter voltage (open base) see Fig. 6			
-I _C = 100 μA	-V _{CEO}	max.	100 V
Emitter-base voltage (open collector) see Fig. 6			
-I _E = 10 μA	-V _{EBO}	max.	6 V
Collector current (d.c.)	-I _C	max.	100 mA
Collector current (peak value)	-I _{CM}	max.	100 mA
Base current (peak value)	-I _{BM}	max.	100 mA
Total power dissipation up to T _{amb} = 25 °C **	P _{tot}	max.	350 mW
Storage temperature	T _{stg}	-65 to +	175 °C
Junction temperature	T _j	max.	175 °C

THERMAL CHARACTERISTICS *

$$T_j = P_x (R_{th j-t} + R_{th t-s} + R_{th s-a}) + T_{amb}$$

Thermal resistance

From junction to tab	R _{th j-t}	=	50 K/W
From tab to soldering points	R _{th t-s}	=	280 K/W
From soldering points to ambient **	R _{th s-a}	=	90 K/W

CHARACTERISTICS

T_j = 25 °C unless otherwise specified

Collector cut-off current			
I _E = 0; -V _{CB} = 90 V	-I _{CBO}	<	100 nA
I _E = 0; -V _{CB} = 90 V; T _j = 150 °C	-I _{CBO}	<	50 μA
Emitter cut-off current			
I _C = 0; -V _{EB} = 6 V	-I _{EBO}	<	200 nA
Saturation voltage			
-I _C = 25 mA; -I _B = 2,5 mA	-V _{CEsat}	<	250 mV
	-V _{BEsat}	<	900 mV
D.C. current gain			
-I _C = 10 mA; -V _{CE} = 1 V	h _{FE}	>	30
-I _C = 25 mA; -V _{CE} = 1 V	h _{FE}	>	30
Collector capacitance at f = 1 MHz			
I _E = I _e = 0; -V _{CB} = 10 V	C _c	typ.	3 pF
Transition frequency at f = 35 MHz			
-I _C = 25 mA; -V _{CE} = 5 V	f _T	>	50 MHz
		typ.	85 MHz

* See *Thermal characteristics*.

** Mounted on a ceramic substrate of 8 mm x 10 mm x 0,7 mm.

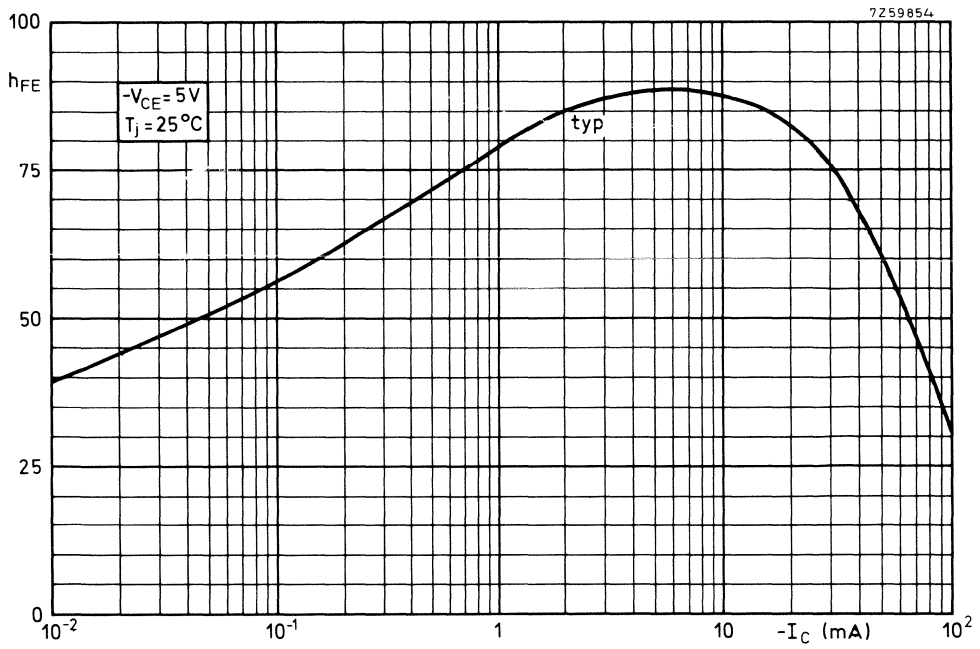

Fig. 2.

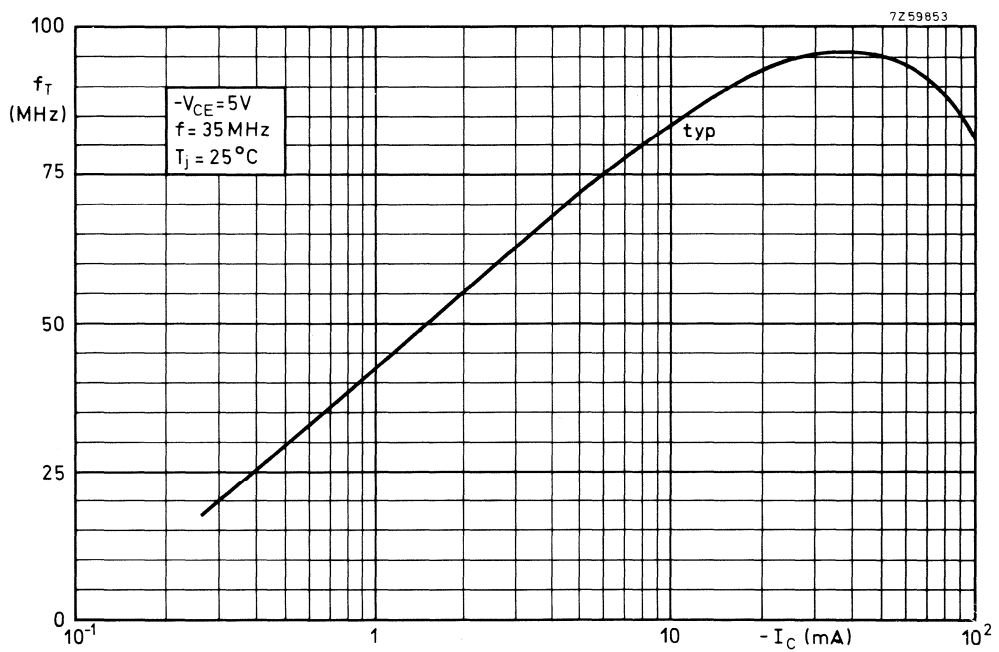

Fig. 3.

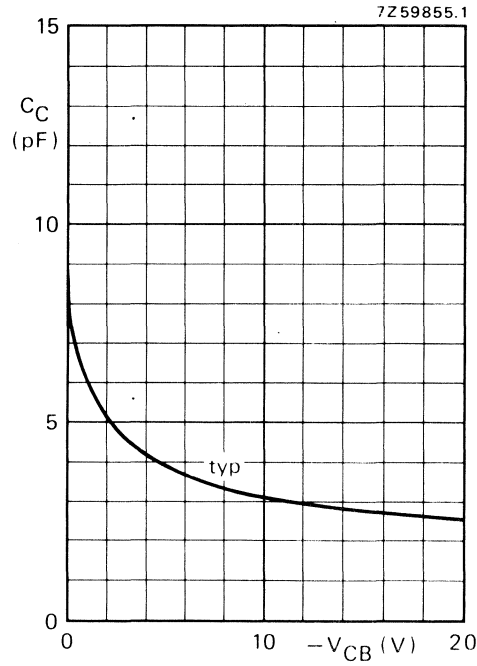

Fig. 4 Typical values collector capacitance as a function of collector-base voltage.
 $I_E = I_e = 0$; $T_j = 25^\circ\text{C}$; $f = 1\text{ MHz}$.

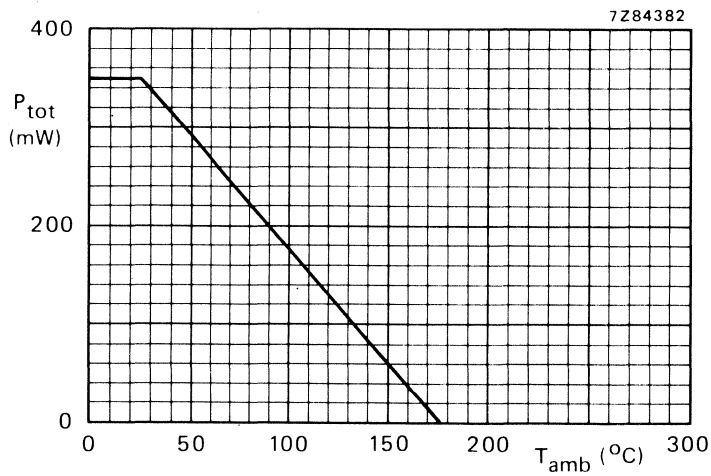

Fig. 5 Power derating curve.

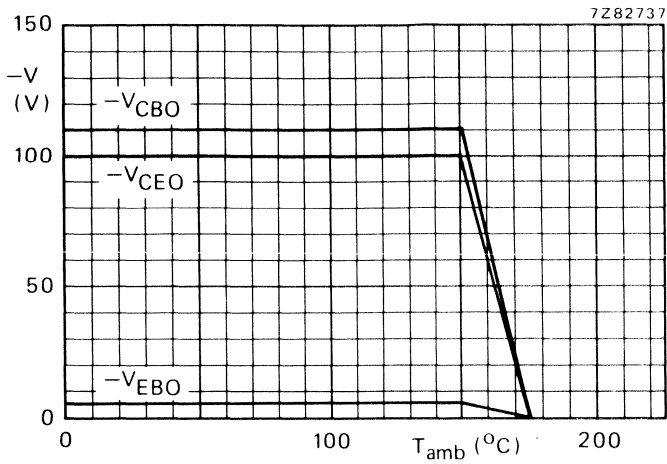

Fig. 6 Voltage derating curves.

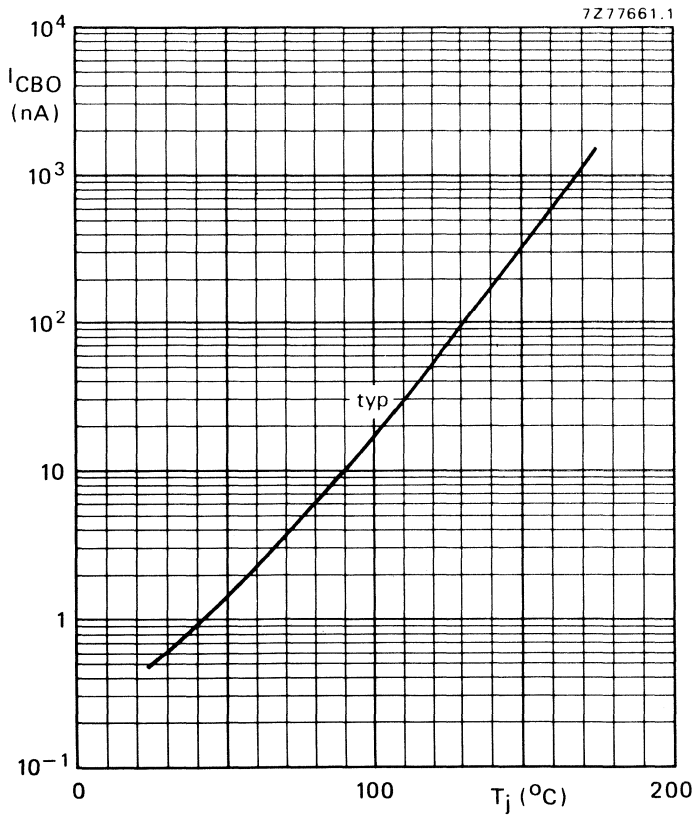

Fig. 7 Typical values collector-base currents as a function of the junction temperature at a collector-base voltage of 90 V.

HIGH VOLTAGE N-P-N TRANSISTORS

Silicon planar epitaxial transistor in a microminiature plastic envelope intended for application in thick and thin-film circuits. This transistor is intended for high-voltage general purpose and switching applications.

QUICK REFERENCE DATA

Collector-base voltage (open emitter)	V_{CBO}	max.	120 V
Collector-emitter voltage (open base)	V_{CEO}	max.	80 V
Collector current (peak value)	I_{CM}	max.	250 mA
Total power dissipation up to $T_{amb} = 25\text{ }^{\circ}\text{C}$	P_{tot}	max.	350 mW
Junction temperature	T_j	max.	175 $^{\circ}\text{C}$
D.C. current gain	h_{FE}	>	20
$I_C = 10\text{ mA}; V_{CE} = 1\text{ V}; T_j = 25\text{ }^{\circ}\text{C}$		typ.	80
Transition frequency at $f = 35\text{ MHz}$	f_T	>	60 MHz
$I_C = 4\text{ mA}; V_{CE} = 10\text{ V}$			
Turn-off time	t_{off}	<	1 μs
$I_C = 15\text{ mA}; I_{Bon} = -I_{Boff} = 1\text{ mA}$			

MECHANICAL DATA

Fig. 1 SOT-23.

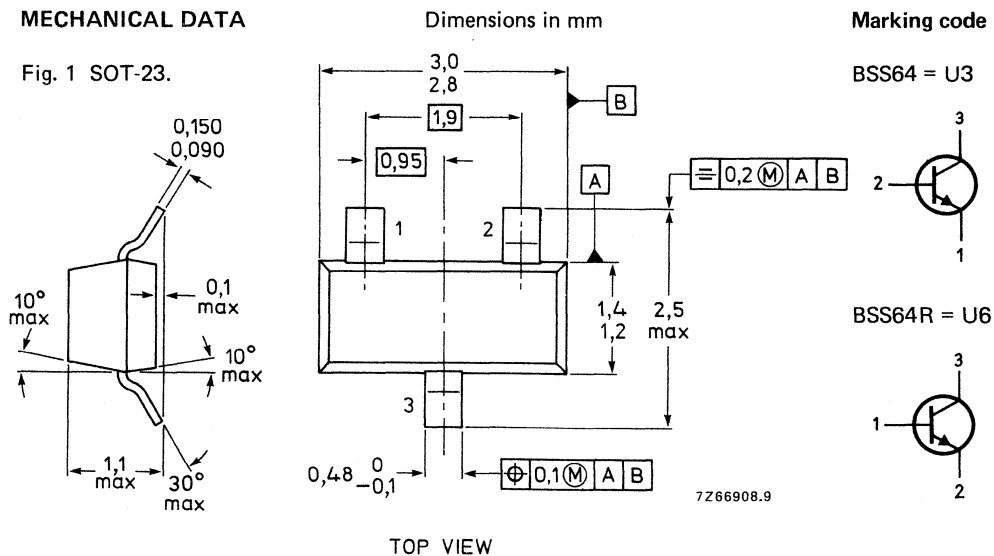

R-types are available on request

See also *Soldering recommendations*.

RATINGS

Limiting values in accordance with the Absolute Maximum System (IEC 134)

Collector-base voltage (open emitter) see Fig. 2

$I_C = 100 \mu\text{A}$

$V_{CBO} \text{ max. } 120 \text{ V}$

Collector-emitter voltage (open base) see Fig. 2

$I_C = 4 \text{ mA}$

$V_{CEO} \text{ max. } 80 \text{ V}$

Emitter-base voltage (open collector) see Fig. 2

$I_E = 100 \mu\text{A}$

$V_{EBO} \text{ max. } 5 \text{ V}$

Collector current

(d.c. or averaged over any 20 ms period)

$I_C \text{ max. } 100 \text{ mA}$

Collector current (peak value)

$I_{CM} \text{ max. } 250 \text{ mA}$

Base current (peak value)

$I_{BM} \text{ max. } 100 \text{ mA}$

Total power dissipation up to $T_{amb} = 25 \text{ }^\circ\text{C}$ **

$P_{tot} \text{ max. } 350 \text{ mW}$

Storage temperature

$T_{stg} -65 \text{ to } +175 \text{ }^\circ\text{C}$

Junction temperature

$T_j \text{ max. } 175 \text{ }^\circ\text{C}$

THERMAL CHARACTERISTICS *

$T_j = P \times (R_{th j-t} + R_{th t-s} + R_{th s-a}) + T_{amb}$

Thermal resistance

From junction to tab

$R_{th j-t} = 50 \text{ K/W}$

From tab to soldering points

$R_{th t-s} = 280 \text{ K/W}$

From soldering points to ambient **

$R_{th s-a} = 90 \text{ K/W}$

CHARACTERISTICS $T_j = 25 \text{ }^\circ\text{C}$ unless otherwise specified

Collector cut-off current

$I_E = 0; V_{CB} = 90 \text{ V}$

$I_{CBO} < 100 \text{ nA}$

$I_E = 0; V_{CB} = 90 \text{ V}; T_j = 150 \text{ }^\circ\text{C}$

$I_{CBO} < 50 \mu\text{A}$

Emitter cut-off current

$I_C = 0; V_{EB} = 5 \text{ V}$

$I_{EBO} \text{ typ. } 0,5 \text{ nA}$

$I_{EBO} < 200 \text{ nA}$

Saturation voltages

$I_C = 4 \text{ mA}; I_B = 400 \mu\text{A}$

$V_{CEsat} < 150 \text{ mV}$

$V_{BEsat} < 1200 \text{ mV}$

$I_C = 50 \text{ mA}; I_B = 15 \text{ mA}$

$V_{CEsat} < 200 \text{ mV}$

D.C. current gain

$I_C = 1 \text{ mA}; V_{CE} = 1 \text{ V}$

$h_{FE} \text{ typ. } 60$

$I_C = 10 \text{ mA}; V_{CE} = 1 \text{ V}$

$h_{FE} > 20$

$h_{FE} \text{ typ. } 80$

$I_C = 20 \text{ mA}; V_{CE} = 1 \text{ V}$

$h_{FE} \text{ typ. } 55$

* See *Thermal characteristics*.

** Mounted on a ceramic substrate of 8 mm x 10 mm x 0,7 mm.

Transition frequency at $f = 35 \text{ MHz}$

$I_C = 4 \text{ mA}; V_{CE} = 10 \text{ V}$

$f_T > 60 \text{ MHz}$
typ. 100 MHz

Collector capacitance at $f = 1 \text{ MHz}$

$I_E = I_e = 0; V_{CB} = 10 \text{ V}$

C_c typ. 3 pF ←

Turn-off switching time

$I_{Con} = 15 \text{ mA}; I_{Bon} = -I_{Boff} = 1 \text{ mA}$

$t_{off} < 1 \mu\text{s}$

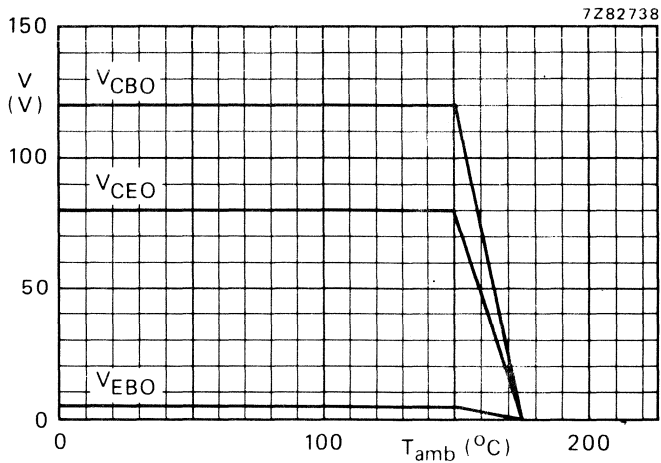

Fig. 2 Voltage derating curves.

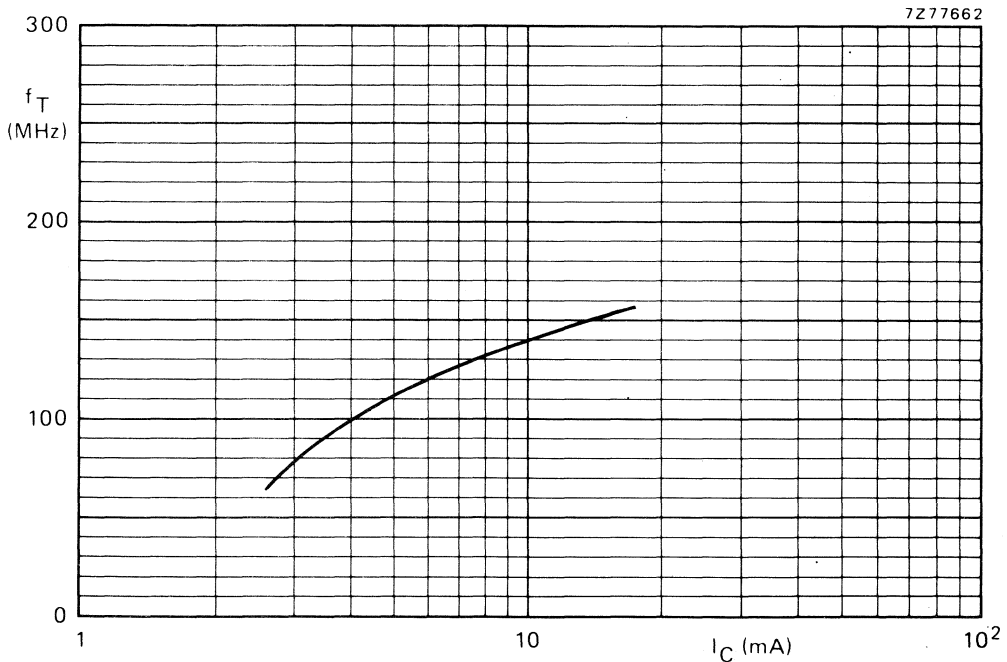

Fig. 3 Typical values transition frequency. $V_{CE} = 10 \text{ V}; f = 35 \text{ MHz}; T_j = 25 \text{ }^\circ\text{C}$.

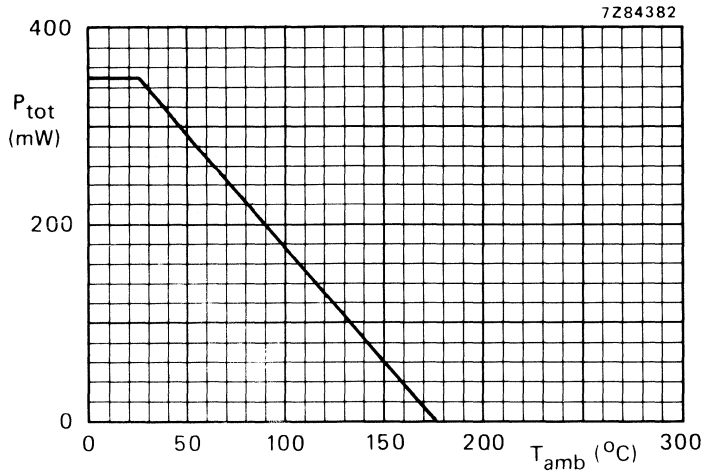

Fig. 4 Power derating curve.

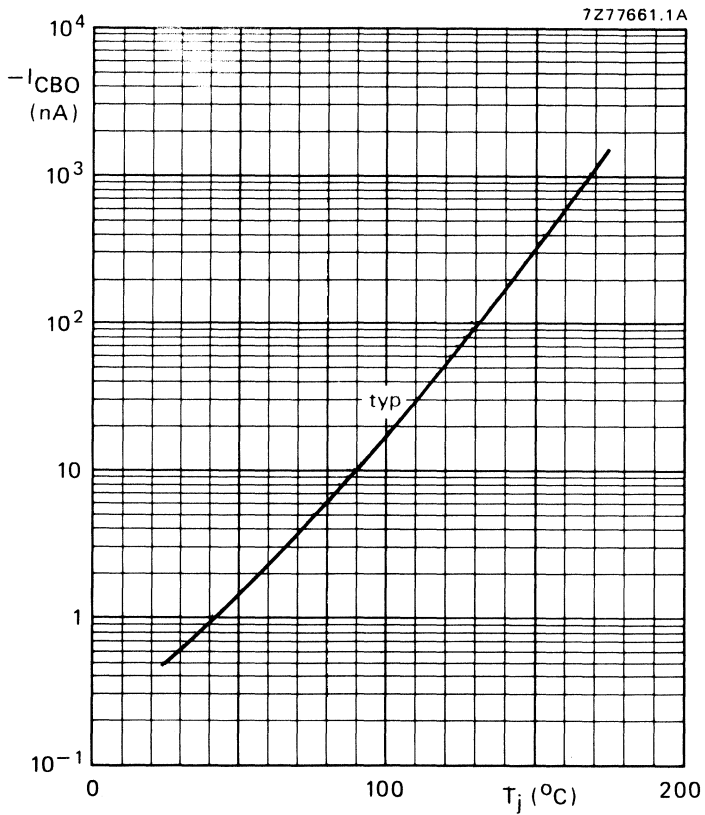

Fig. 5 Typical values collector-base current as a function of the junction temperature at a collector-base voltage of -90 V.

MOSFET N-CHANNEL ENHANCEMENT SWITCHING TRANSISTOR

Symmetrical insulated-gate silicon MOS field-effect transistor of the N-channel enhancement mode type. The transistor is sealed in a SOT-143 envelope and features a low ON resistance and low capacitances. The transistor is protected against excessive input voltages by integrated back-to-back diodes between gate and substrate.

Applications:

- analog and/or digital switch
- switch driver

QUICK REFERENCE DATA

Drain-source voltage	V_{DS}	max.	10 V
Source-drain voltage	V_{SD}	max.	10 V
Drain-substrate voltage	V_{DB}	max.	15 V
Source-substrate voltage	V_{SB}	max.	15 V
Drain current (d.c.)	I_D	max.	50 mA
Total power dissipation up to $T_{amb} = 25\text{ }^{\circ}\text{C}$	P_{tot}	max.	230 mW
Gate-source cut-off voltage $V_{DS} = V_{GS}; V_{SB} = 0;$ $I_D = 1\text{ }\mu\text{A}$	$V_{(P)GS}$	> <	0,1 V 2,0 V
Drain-source ON-resistance $V_{GS} = 10\text{ V}; V_{SB} = 0; I_D = 0,1\text{ mA}$	$R_{DS(on)}$	<	45 Ω
Feed-back capacitance $V_{GS} = V_{BS} = -15\text{ V};$ $V_{DS} = 10\text{ V}; f = 1\text{ MHz}$	C_{rss}	typ.	0,6 pF

MECHANICAL DATA

SOT-143 (see Fig. 1).

See also *Soldering recommendations*.

Fig. 1 SOT-143.

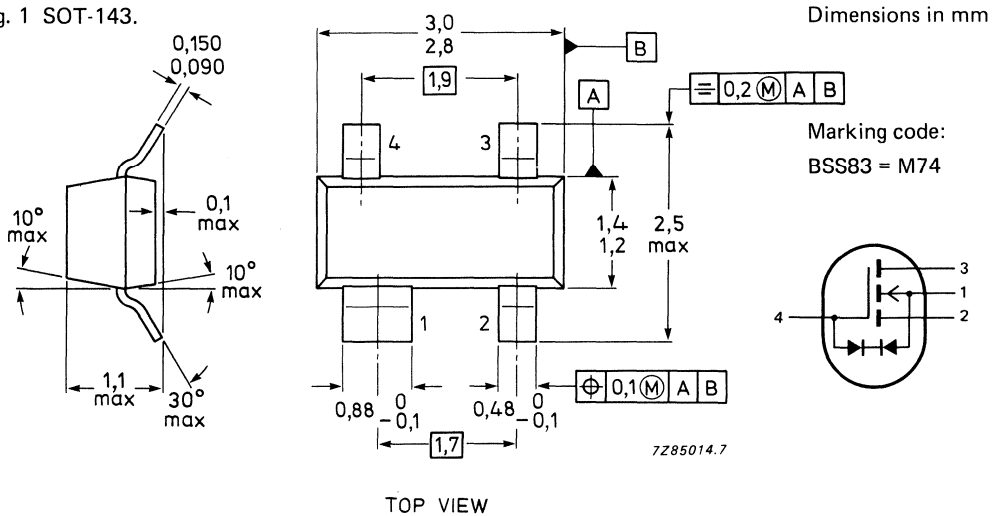

RATINGS

Limiting values in accordance with the Absolute Maximum System (IEC 134)

Drain-source voltage	V_{DS}	max.	10 V
Source-drain voltage	V_{SD}	max.	10 V
Drain-substrate voltage	V_{DB}	max.	15 V
Source-substrate voltage	V_{SB}	max.	15 V
Drain current (d.c.)	I_D	max.	50 mA
Total power dissipation up to $T_{amb} = 25\text{ °C}^*$	P_{tot}	max.	230 mW*
Storage temperature range	T_{stg}		-65 to +150 °C
Junction temperature	T_j	max.	125 °C

THERMAL RESISTANCE

From junction to ambient in free air*	$R_{th\ j-a}$	=	430 K/W*
---------------------------------------	---------------	---	----------

CHARACTERISTICS

$T_{amb} = 25\text{ °C}$ unless otherwise specified

Drain-source breakdown voltage $V_{GS} = V_{BS} = -5\text{ V}; I_D = 10\text{ nA}$	$V_{(BR)DSX}$	>	10 V
Source-drain breakdown voltage $V_{GD} = V_{BD} = -5\text{ V}; I_D = 10\text{ nA}$	$V_{(BR)SDX}$	>	10 V
Drain-substrate breakdown voltage → $V_{DB} = 0; I_D = 10\text{ nA};$ open source	$V_{(BR)DBO}$	>	15 V
Source-substrate breakdown voltage → $V_{DB} = 0; I_D = 10\text{ nA};$ open drain	$V_{(BR)SBO}$	>	15 V
Drain-source leakage current $V_{GS} = V_{BS} = -2\text{ V}; V_{DS} = 6,6\text{ V}$	I_{DSoff}	<	10 nA

→ * Device mounted on a ceramic substrate of 8 mm x 10 mm x 0,7 mm.

Source-drain leakage current

$$V_{GD} = V_{BD} = -2 \text{ V}; V_{SD} = 6,6 \text{ V}$$

$$I_{SDoff} < 10 \text{ nA} \leftarrow$$

Forward transconductance at $f = 1 \text{ kHz}$

$$V_{DS} = 10 \text{ V}; V_{SB} = 0; I_D = 20 \text{ mA}$$

$$g_{fs} > 10 \text{ mS}$$

$$\text{typ. } 15 \text{ mS}$$

Gate-source cut-off voltage

$$V_{DS} = V_{GS}; V_{SB} = 0; I_D = 1 \mu\text{A}$$

$$V_{(P)GS} > 0,1 \text{ V}$$

$$< 2,0 \text{ V}$$

Drain-source ON-resistance

$$I_D = 0,1 \text{ mA};$$

$$V_{GS} = 5 \text{ V}; V_{SB} = 0$$

$$R_{DS(on)} < 70 \Omega$$

$$V_{GS} = 10 \text{ V}; V_{SB} = 0$$

$$R_{DS(on)} < 45 \Omega$$

$$V_{GS} = 3,2 \text{ V}; V_{SB} = 6,8 \text{ V (see Fig. 4)}$$

$$R_{DS(on)} \text{typ. } 80 \Omega$$

$$< 120 \Omega$$

Gate-substrate zener voltages

$$V_{DB} = V_{SB} = 0; -I_C = 10 \mu\text{A}$$

$$V_{Z(1)} > 12,5 \text{ V}$$

$$V_{DB} = V_{SB} = 0; +I_G = 10 \mu\text{A}$$

$$V_{Z(2)} > 12,5 \text{ V}$$

Capacitances at $f = 1 \text{ MHz}$

$$V_{GS} = V_{BS} = -15 \text{ V}; V_{DS} = 10 \text{ V}$$

Feed-back capacitance

$$C_{rss} \text{typ. } 0,6 \text{ pF}$$

Input capacitance

$$C_{iss} \text{typ. } 1,5 \text{ pF}$$

Output capacitance

$$C_{oss} \text{typ. } 1,0 \text{ pF}$$

Switching times (see Fig. 2)

$$V_{DD} = 10 \text{ V}; V_i = 5 \text{ V}$$

$$t_{on} \text{typ. } 1,0 \text{ ns}$$

$$t_{off} \text{typ. } 5,0 \text{ ns}$$

Pulse generator:

$$R_i = 50 \Omega$$

$$t_r < 0,5 \text{ ns}$$

$$t_f < 1,0 \text{ ns}$$

$$t_p = 20 \text{ ns}$$

$$\delta < 0,01$$

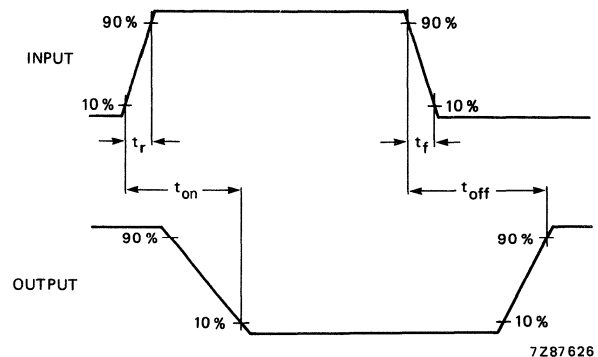
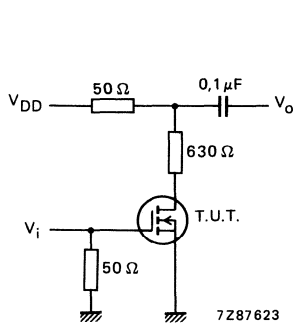

Fig. 2 Switching times test circuit and input and output waveforms.

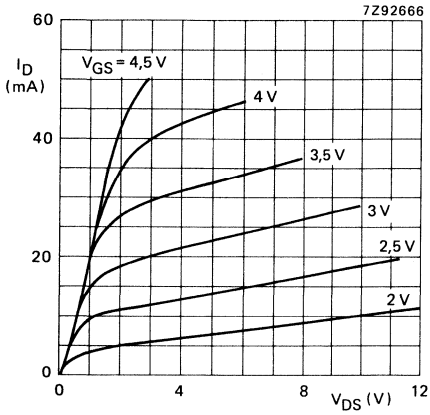

Fig. 3 $V_{SB} = 0$; typical values.

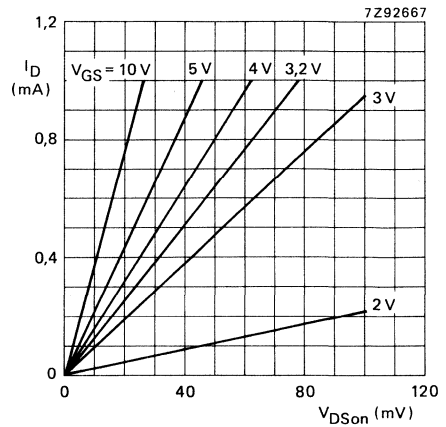

Fig. 4 $V_{SB} = 6,8$ V; typical values.

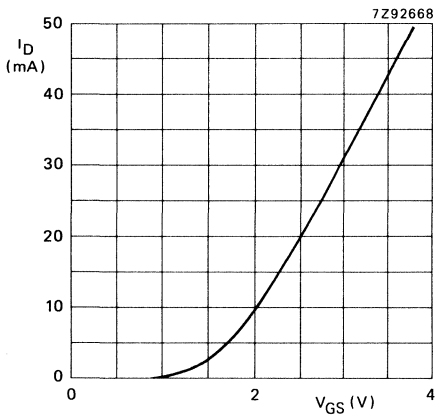

Fig. 5 $V_{DS} = 10$ V; $V_{BS} = 0$; typical values.

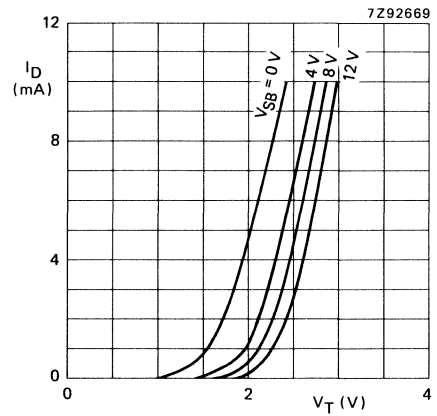

Fig. 6 $V_{DS} = V_{GS} = V_T$.

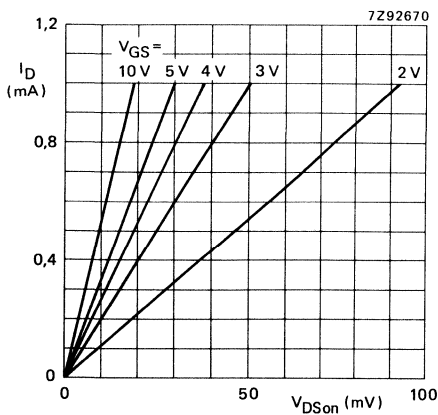

Fig. 7 $V_{SB} = 0$; typical values.

Conditions for Figs 3, 4, 5, 6 and 7:
 $T_j = 25$ °C.

SILICON PLANAR EPITAXIAL TRANSISTORS

P-N-P transistors in miniature plastic envelopes intended for use in amplifier and switching applications. Complementary types are BST39/40.

QUICK REFERENCE DATA

	BST15	BST16
Collector-base voltage (open emitter)	$-V_{CBO}$ max. 200	350 V
Collector-emitter voltage (open base)	$-V_{CEO}$ max. 200	300 V
Collector current (d.c.)	$-I_C$ max. 1	A
Total power dissipation up to $T_{amb} = 25\text{ }^\circ\text{C}$	P_{tot} max. 1	W
Junction temperature	T_j max. 150	$^\circ\text{C}$
D.C. current gain		
$-V_{CE} = 10\text{ V}; -I_C = 50\text{ mA}$	h_{FE} 30 to 150	30 to 120
Transition frequency		
$-V_{CE} = 10\text{ V}; -I_C = 10\text{ mA}$	$f_T >$	15 MHz

MECHANICAL DATA

Fig. 1 SOT-89.

Dimensions in mm

Marking:

BST15 = BT1
BST16 = BT2

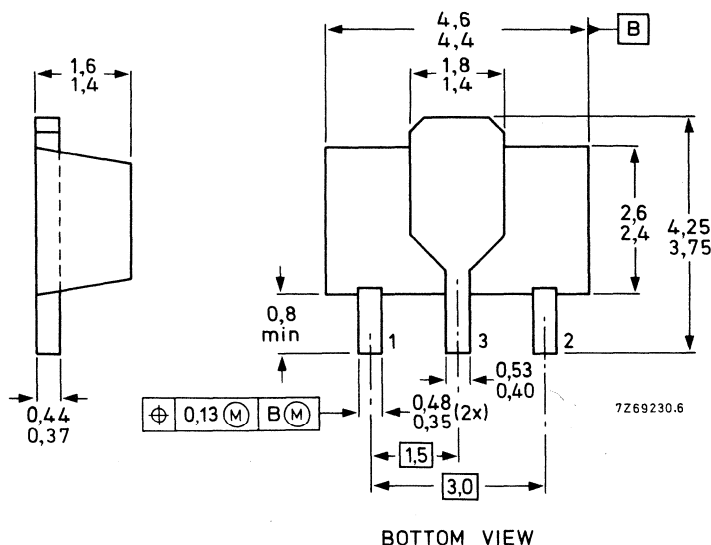

See also *Soldering Recommendations*

RATINGS

Limiting values in accordance with the Absolute Maximum System (IEC 134)

		BST15	BST16
Collector-base voltage (open emitter)	$-V_{CBO}$	max. 200	350 V
Collector-emitter voltage (open base)	$-V_{CEO}$	max. 200	300 V
Emitter-base voltage (open collector)	$-V_{EBO}$	max. 4	6 V
Collector current (d.c.)	$-I_C$	max. 1	A
Base current	$-I_B$	max. 0,5	A
Total power dissipation up to $T_{amb} = 25\text{ }^\circ\text{C}^*$	P_{tot}	max. 1	W
Junction temperature	T_j	max. 150	$^\circ\text{C}$
Storage temperature	T_{stg}	-65 to 150 $^\circ\text{C}$	

THERMAL RESISTANCE

from junction to ambient*	$R_{th\ j-mb}$	=	125	K/W
from junction to collector tab	$R_{th\ j-tab}$	=	10	K/W

CHARACTERISTICS

$T_j = 25\text{ }^\circ\text{C}$ unless otherwise specified

		BST15	BST16
Collector cut-off current			
$I_E = 0; -V_{CB} = 175\text{ V}$	$-I_{CBO}$	< 1	- μA
$I_E = 0; -V_{CB} = 280\text{ V}$	$-I_{CBO}$	< -	1 μA
$I_B = 0; -V_{CE} = 150\text{ V}$	$-I_{CEO}$	< 50	- μA
$I_B = 0; -V_{CE} = 250\text{ V}$	$-I_{CEO}$	< -	50 μA
Emitter cut-off current			
$I_C = 0; -V_{EB} = 4\text{ V}$	$-I_{EBO}$	< 20	- μA
$I_C = 0; -V_{EB} = 6\text{ V}$	$-I_{EBO}$	< -	20 μA
Collector-emitter breakdown voltage			
$I_B = 0; -I_C = 50\text{ mA}; L = 25\text{ mH}$	$-V_{(BR)CEO}$	> 200	300 V
Collector-emitter saturation voltage			
$-I_C = 50\text{ mA}; -I_B = 5\text{ mA}$	$-V_{CEsat}$	< 2,5	2,0 V
D.C. current gain			
$-V_{CE} = 10\text{ V}; -I_C = 50\text{ mA}$	h_{FE}	30 to 150	30 to 120
Transition frequency at $f = 30\text{ MHz}$			
$-I_C = 10\text{ mA}; -V_{CE} = 10\text{ V}$	f_T	>	15 MHz
Collector capacitance at $f = 1\text{ MHz}$			
$I_E = I_e = 0; -V_{CB} = 10\text{ V}$	C_c	<	15 pF

* Mounted on an area of 2,5 cm² of a ceramic substrate; thickness 0,7 mm.

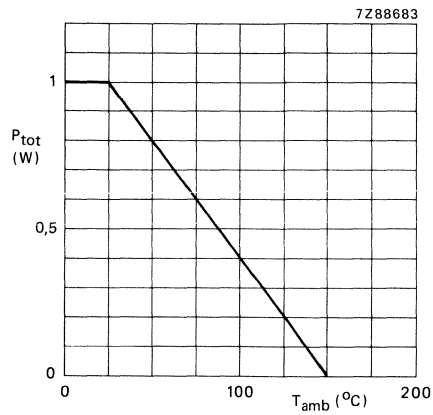

Fig. 2 Power derating curve.

SILICON PLANAR EPITAXIAL TRANSISTORS

N-P-N transistors in miniature plastic envelopes intended for use in amplifier and switching applications. Complementary p-n-p types are BST15/16.

QUICK REFERENCE DATA

		BST39		BST40	
Collector-base voltage (open emitter)	V_{CB0}	max.	400	300	V
Collector-emitter voltage (open base)	V_{CEO}	max.	350	250	V
Collector current (d.c.)	I_C	max.		1	A
Total power dissipation up to $T_{amb} = 25\text{ }^\circ\text{C}$	P_{tot}	max.		1	W
Junction temperature	T_j	max.		150	$^\circ\text{C}$
D.C. current gain	h_{FE}	min.		40	
$V_{CE} = 10\text{ V}; I_C = 20\text{ mA}$					
Transition frequency at $f = 5\text{ MHz}$	f_T	min.		70	MHz
$V_{CE} = 10\text{ V}; I_C = 10\text{ mA}$					

MECHANICAL DATA

Fig. 1 SOT-89.

Dimensions in mm

Marking
BST39 = AT1
BST40 = AT2

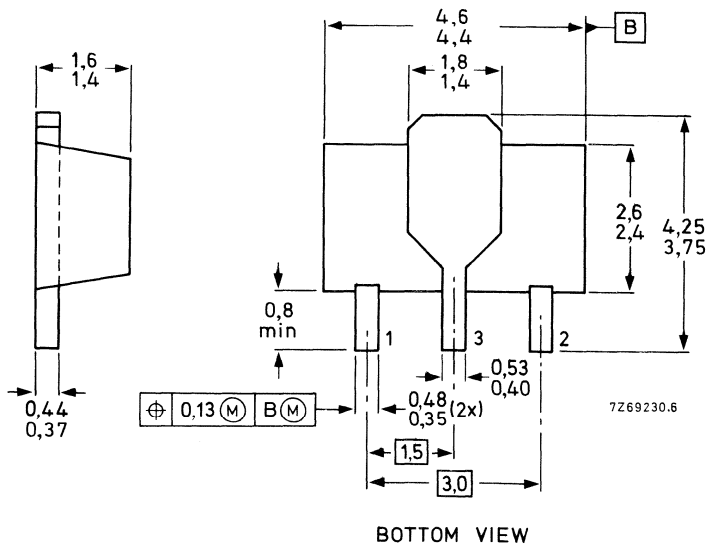

See also *Soldering Recommendations*.

RATINGS

Limiting values in accordance with the Absolute Maximum System (IEC 134)

			BST39	BST40	
→ Collector-base voltage (open emitter)	V_{CBO}	max.	400	300	V
Collector-emitter voltage (open base)	V_{CEO}	max.	350	250	V
Emitter-base voltage (open collector)	V_{EBO}	max.	5		V
Collector current (d.c.)	I_C	max.	1		A
Base current	I_B	max.	0,5		A
Total power dissipation up to $T_{amb} = 25\text{ }^\circ\text{C}^*$	P_{tot}	max.	1		W
Junction temperature	T_j	max.	150		$^\circ\text{C}$
Storage temperature	T_{stg}		-65 to 150		$^\circ\text{C}$

THERMAL RESISTANCE

from junction to ambient*	$R_{th\ j-a}$	=	125		K/W
---------------------------	---------------	---	-----	--	-----

CHARACTERISTICS

$T_j = 25\text{ }^\circ\text{C}$ unless otherwise specified

Collector cut-off current

$I_B = 0; V_{CE} = 300\text{ V}$

I_{CBO}	\leq	20	nA
-----------	--------	----	----

Emitter cut-off current

$I_C = 0; V_{EB} = 5\text{ V}$

I_{EBO}	\leq	10	μA
-----------	--------	----	---------------

Collector-emitter saturation voltage

$I_C = 50\text{ mA}; I_B = 4\text{ mA}$

V_{CEsat}	\leq	0,5	V
-------------	--------	-----	---

Base-emitter saturation voltage

$I_C = 50\text{ mA}; I_B = 4\text{ mA}$

V_{BEsat}	\leq	1,3	V
-------------	--------	-----	---

D.C. current gain

$V_{CE} = 10\text{ V}; I_C = 20\text{ mA}$

h_{FE}	\leq	40	
----------	--------	----	--

Collector capacitance at $f = 1\text{ MHz}$

$I_E = i_e = 0; V_{CB} = 10\text{ V}$

C_c	\leq	2	pF
-------	--------	---	----

Emitter capacitance at $f = 1\text{ MHz}$

$I_C = I_c = 0; V_{EB} = 5\text{ V}$

C_e	\leq	20	pF
-------	--------	----	----

Transition frequency at $f = 5\text{ MHz}$

$V_{CE} = 10\text{ V}; I_C = 10\text{ mA}$

f_T	\geq	70	MHz
-------	--------	----	-----

* Mounted on an area of $2,5\text{ cm}^2$ of a ceramic substrate; thickness 0,7 mm.

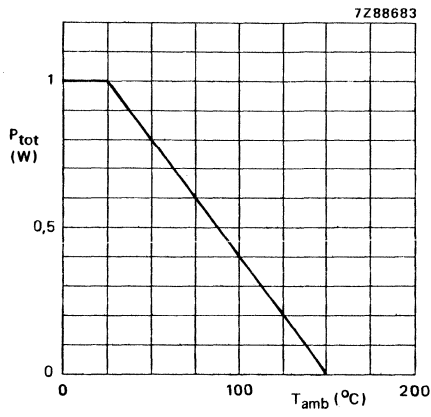

Fig. 2 Power derating curve.

N-P-N SILICON PLANAR DARLINGTON TRANSISTORS

Silicon n-p-n planar Darlington transistors for industrial switching applications, e.g. print hammer, solenoid, relay and lamp driving. Encapsulated in a microminiature SOT-89 envelope.

P-N-P complements are BST60, 61, 62 respectively.

QUICK REFERENCE DATA

		BST50	BST51	BST52	
Collector-base voltage (open emitter)	V_{CBO}	max. 60	80	90	V
Collector-emitter voltage	V_{CER}	max. 45	60	80	V
Collector current	I_C	max. 0,5	0,5	0,5	A
Total power dissipation up to $T_{amb} = 25\text{ }^\circ\text{C}$	P_{tot}	max. 1			W
D.C. current gain $I_C = 500\text{ mA}; V_{CE} = 10\text{ V}$	h_{FE}	> 2000			
Collector-emitter saturation voltage $I_C = 500\text{ mA}; I_B = 0,5\text{ mA}$	V_{CEsat}	< 1,3			V
Turn-off time $I_C = 500\text{ mA}; I_{Bon} = -I_{Boff} = 0,5\text{ mA}$	t_{off}	typ. 1500			ns

MECHANICAL DATA

Fig. 1 SOT-89.

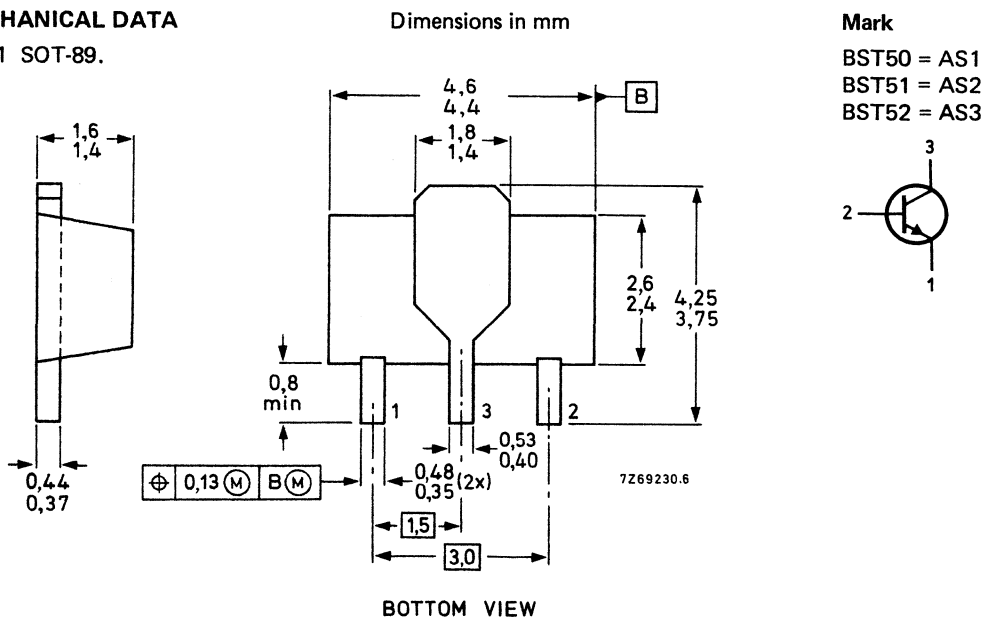

See also *Soldering recommendations*.

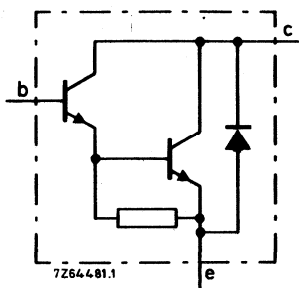

Fig. 2 Circuit diagram.

RATINGS

Limiting values in accordance with the Absolute Maximum System (IEC 134)

			BST50	BST51	BST52
Collector-base voltage (open emitter)	V_{CBO}	max.	60	80	90 V
Collector-emitter voltage*	V_{CER}	max.	45	60	80 V
Emitter-base voltage (open collector)	V_{EBO}	max.	5		V
Collector current (d.c.)	I_C	max.	0,5		A
Collector current (peak)	I_{CM}	max.	1,5		A
Base current (d.c.)	I_B	max.	0,1		A
Total power dissipation [▲] up to $T_{amb} = 25\text{ }^{\circ}\text{C}$	P_{tot}	max.	1		W
Storage temperature	T_{stg}		-65 to + 150		$^{\circ}\text{C}$
Junction temperature**	T_j	max.	150		$^{\circ}\text{C}$

THERMAL RESISTANCE**

From junction to ambient [▲]	$R_{th\ j-a}$	=	125	K/W
From junction to tab	$R_{th\ j-tab}$	=	10	K/W

* External R_{BE} not to exceed value shown in Fig. 5.

** Based on maximum average junction temperature in line with common industrial practice. The resulting higher junction temperature of the output transistor part is taken into account.

▲ Device mounted on a ceramic substrate; area = 2,5 cm², thickness = 0,7 mm.

CHARACTERISTICS

$T_j = 25\text{ }^\circ\text{C}$ unless otherwise specified

Collector cut-off current

$V_{BE} = 0; V_{CE} = V_{CE\text{max}}$

$I_{CES} < 10\text{ }\mu\text{A}$

Emitter cut-off current

$I_C = 0; V_{EB} = 4\text{ V}$

$I_{EBO} < 10\text{ }\mu\text{A}$

D.C. current gain*

$I_C = 150\text{ mA}; V_{CE} = 10\text{ V}$

$h_{FE} > 1000$

$I_C = 500\text{ mA}; V_{CE} = 10\text{ V}$

$h_{FE} > 2000$

Collector-emitter saturation voltage

$I_C = 500\text{ mA}; I_B = 0,5\text{ mA}$

$V_{CE\text{sat}} < 1,3\text{ V}$

$I_C = 500\text{ mA}; I_B = 0,5\text{ mA}; T_j = 150\text{ }^\circ\text{C}$

$V_{CE\text{sat}} < 1,3\text{ V}$

Base-emitter saturation voltage

$I_C = 500\text{ mA}; I_B = 0,5\text{ mA}$

$V_{BE\text{sat}} < 1,9\text{ V}$

Switching times (see also Fig. 3 and Fig. 4)

$I_C = 500\text{ mA}; I_{B\text{on}} = -I_{B\text{off}} = 0,5\text{ mA}$

Turn-on time

t_{on} typ. 400 ns

Turn-off time

t_{off} typ. 1500 ns

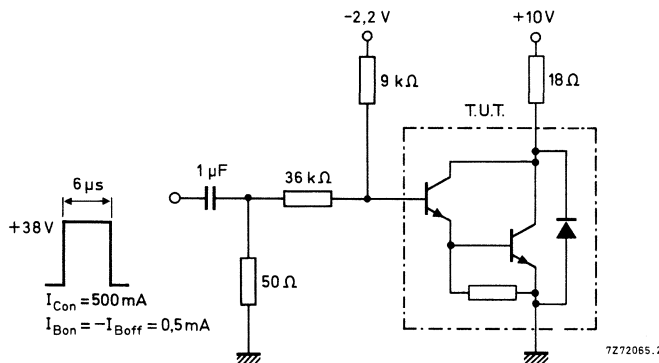
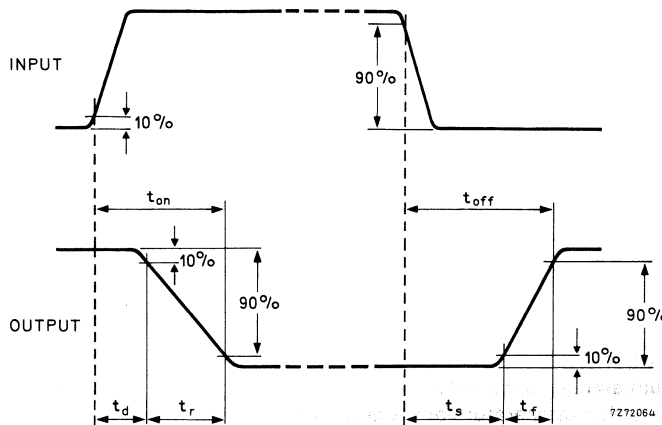

Fig. 3 Switching times test circuit.



* Fig. 4 Switching times waveform.

* Measured under pulsed conditions.

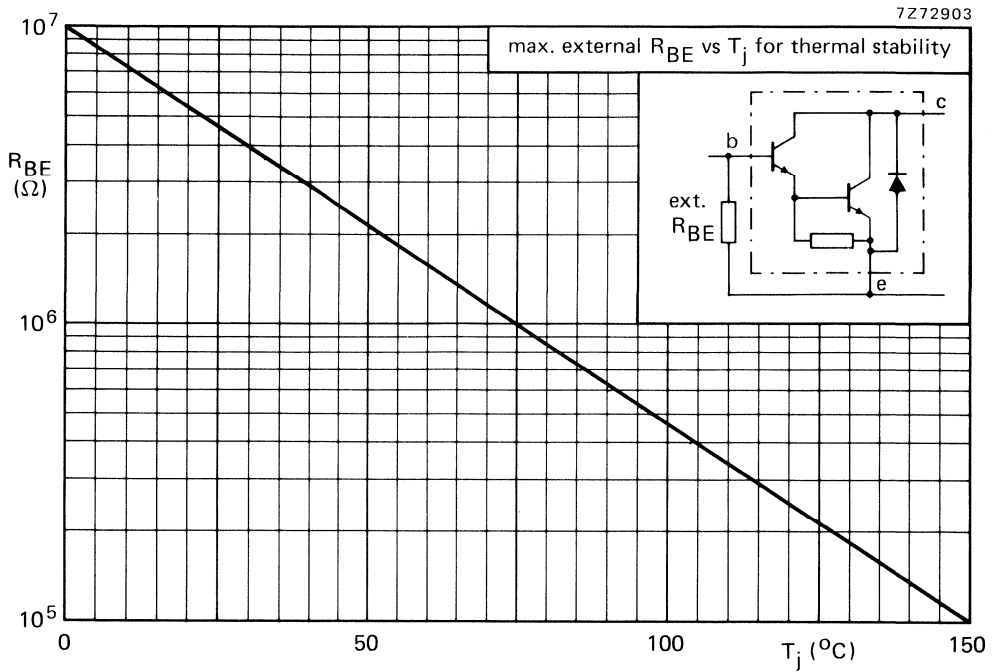

Fig. 5 Maximum values external R_{BE} as a function of junction temperature.

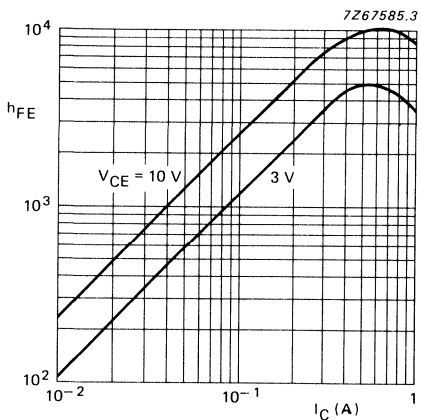

Fig. 6 $T_j = 25^{\circ}\text{C}$.

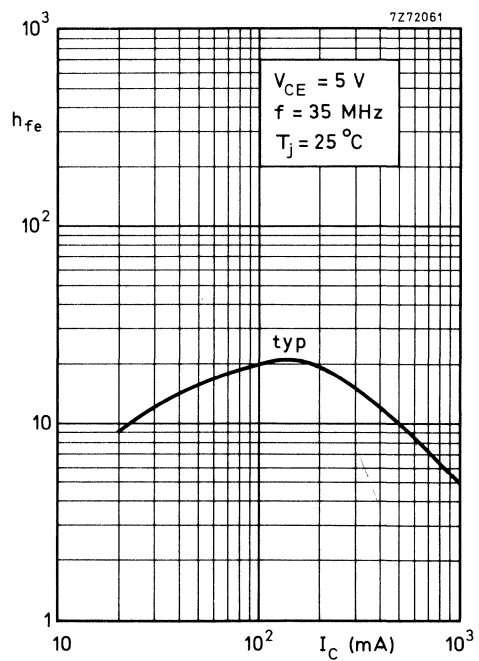

Fig. 7.

P-N-P SILICON PLANAR DARLINGTON TRANSISTORS

Silicon p-n-p planar Darlington transistors for industrial switching applications, e.g. print hammer, solenoid, relay and lamp driving. Encapsulated in a microminiature plastic SOT-89 envelope.

N-P-N complements are BST50, BST51 and BST52 respectively.

QUICK REFERENCE DATA

			BST60	BST61	BST62	
Collector-base voltage (open emitter)	$-V_{CBO}$	max.	60	80	90	V
Collector-emitter voltage	$-V_{CER}$	max.	45	60	80	V
Collector current	$-I_C$	max.	0,5	0,5	0,5	A
Total power dissipation up to $T_{amb} = 25\text{ }^\circ\text{C}$	P_{tot}	max.	1			W
D.C. current gain $-I_C = 500\text{ mA}; -V_{CE} = 10\text{ V}$	h_{FE}	>	2000			
Collector-emitter saturation voltage $-I_C = 0,5\text{ A}; -I_B = 0,5\text{ mA}$	$-V_{CEsat}$	<	1,3			V
Turn-off time $-I_C = 500\text{ mA}; -I_{Bon} = I_{Boff} = 0,5\text{ mA}$	t_{off}	typ.	1500			ns

MECHANICAL DATA

Fig. 1 SOT-89.

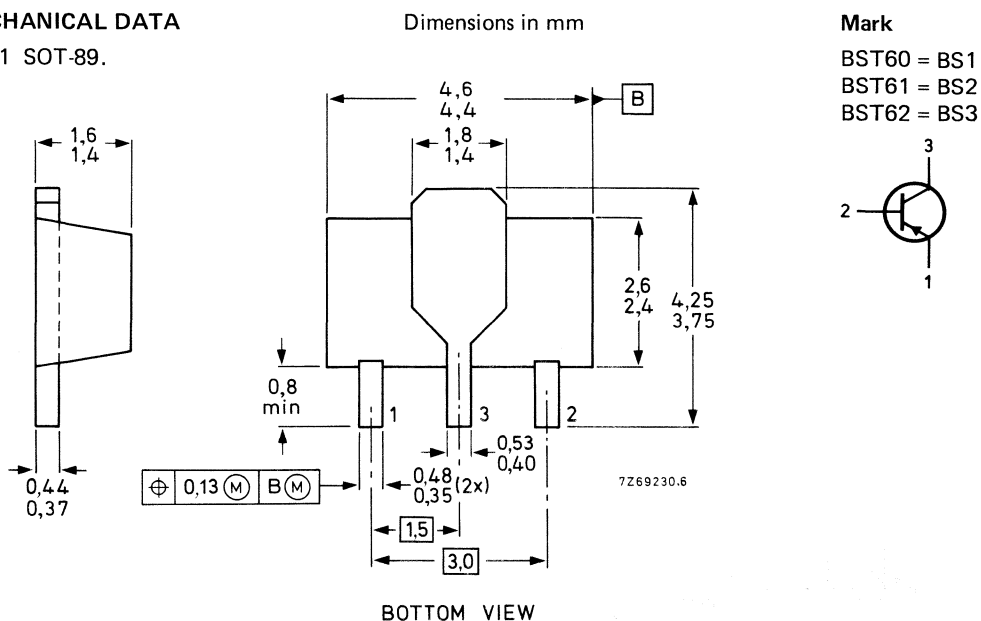

See also *Soldering recommendations*.

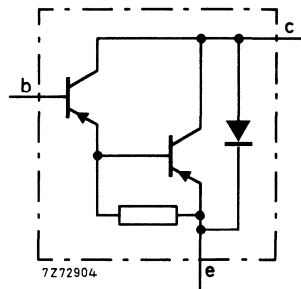

Fig. 2 Circuit diagram.

RATINGS

Limiting values in accordance with the Absolute Maximum System (IEC 134)

			BST60	BST61	BST62	
Collector-base voltage (open emitter)	$-V_{CBO}$	max.	60	80	90	V
Collector-emitter voltage*	$-V_{CER}$	max.	45	60	80	V
Emitter-base voltage (open collector)	$-V_{EBO}$	max.	5			V
Collector current (d.c.)	$-I_C$	max.	0,5			A
Collector current (peak)	$-I_{CM}$	max.	1,5			A
Base current (d.c.)	$-I_B$	max.	0,1			A
Total power dissipation▲ up to $T_{amb} = 25\text{ }^\circ\text{C}$	P_{tot}	max.	1			W
Storage temperature	T_{stg}		-65 to + 150			$^\circ\text{C}$
Junction temperature**	T_j	max.	150			$^\circ\text{C}$

THERMAL RESISTANCE**

From junction to ambient▲	$R_{th\ j-a}$	=	125	K/W
From junction to tab	$R_{th\ j-tab}$	=	10	K/W

* External R_{BE} not to exceed value shown in Fig. 5.

** Based on maximum average junction temperature in line with common industrial practice. The resulting higher junction temperature of the output transistor part is taken into account.

▲ Device mounted on a ceramic substrate area 2,5 cm², thickness = 0,7 mm.

CHARACTERISTICS

$T_j = 25\text{ }^\circ\text{C}$ unless otherwise specified

Collector cut-off current

$V_{BE} = 0; -V_{CE} = -V_{CERmax}$ $-I_{CES} < 10\text{ }\mu\text{A}$

Emitter cut-off current

$I_C = 0; V_{EB} = 4\text{ V}$ $-I_{EBO} < 10\text{ }\mu\text{A}$

D.C. current gain*

$-I_C = 150\text{ mA}; -V_{CE} = 10\text{ V}$ $h_{FE} > 1000$

$-I_C = 500\text{ mA}; -V_{CE} = 10\text{ V}$ $h_{FE} > 2000$

Collector-emitter saturation voltage

$-I_C = 500\text{ mA}; -I_B = 0,5\text{ mA}$ $-V_{CEsat} < 1,3\text{ V}$

$-I_C = 500\text{ mA}; -I_B = 0,5\text{ mA}; T_j = 150\text{ }^\circ\text{C}$ $-V_{CEsat} < 1,3\text{ V}$

Base-emitter saturation voltage

$-I_C = 500\text{ mA}; -I_B = 0,5\text{ mA}$ $-V_{BEsat} < 1,9\text{ V}$

Switching times (see also Fig. 3 and Fig. 4)

$-I_C = 500\text{ mA}; -I_{Bon} = -I_{Boff} = 0,5\text{ mA}$

Turn-on time t_{on} typ. 400 ns

Turn-off time t_{off} typ. 1500 ns

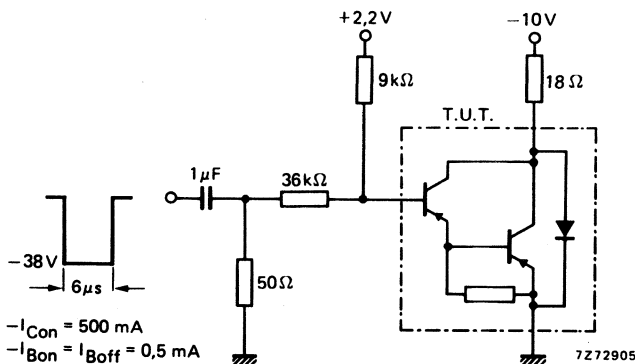

Fig. 3 Switching times test circuit.

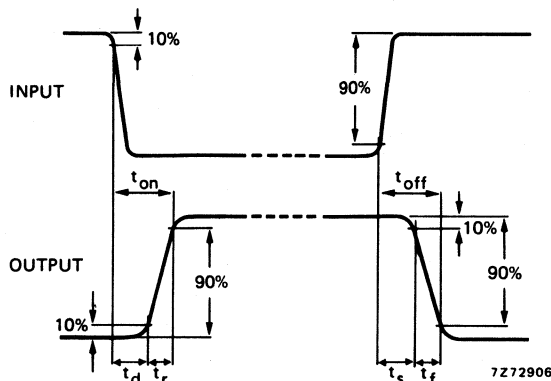

Fig. 4 Switching times waveform.

* Measured under pulsed conditions.

7Z72979

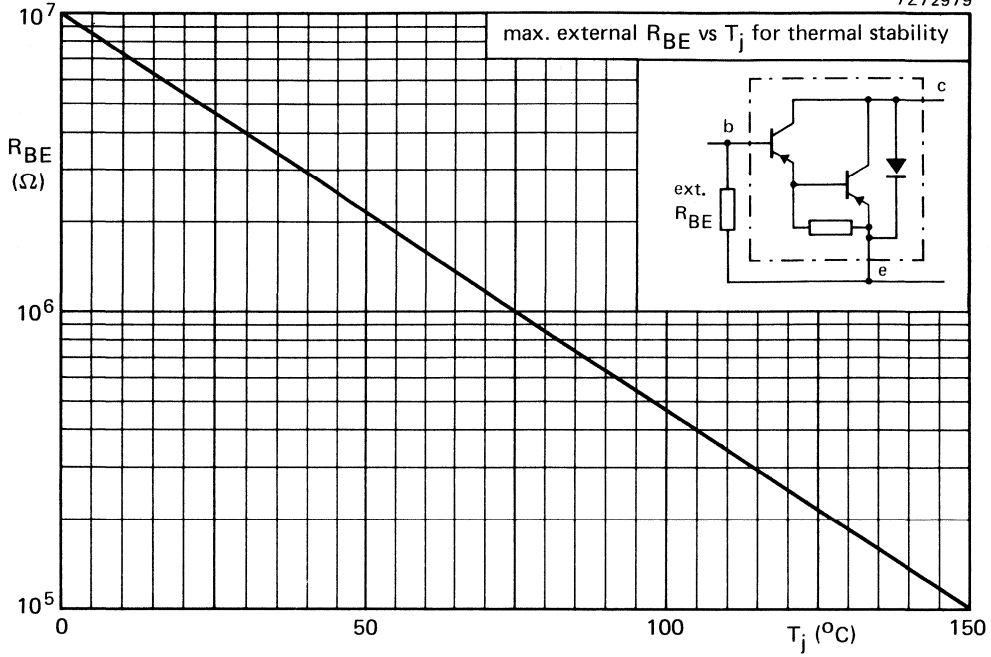

Fig. 5 Maximum values external R_{BE} as a function of junction temperature.

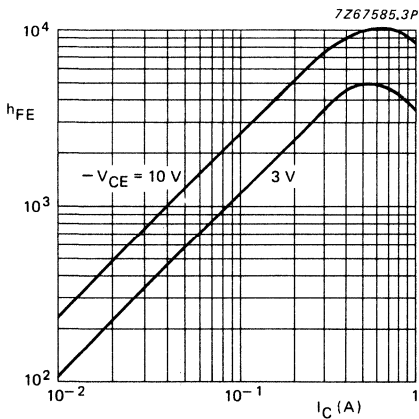

Fig. 6 $T_j = 25\text{ }^{\circ}\text{C}$.

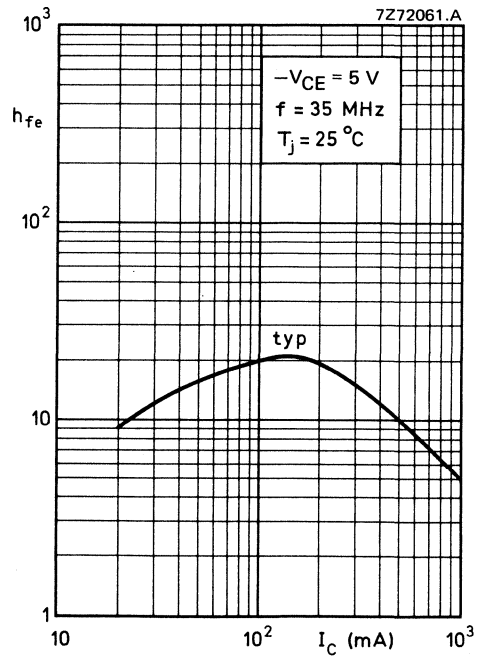

Fig. 7.

N-CHANNEL VERTICAL D-MOS TRANSISTOR

N-channel enhancement mode vertical D-MOS transistor in SOT-89 envelope and designed for use as Surface Mounted Device (SMD) in thin and thick-film circuits for application with relay, high-speed and line-transformer drivers.

Features

- Very low R_{DSon}
- Direct interface to C-MOS, TTL, etc.
- High-speed switching
- No second breakdown

QUICK REFERENCE DATA

Drain-source voltage	V_{DS}	max.	80 V
Gate-source voltage (open drain)	V_{GS}	max.	20 V
Drain current (d.c.)	I_D	max.	0,5 A
Total power dissipation up to $T_{amb} = 25\text{ }^\circ\text{C}$	P_{tot}	max.	1 W
Drain-source ON-resistance $I_D = 500\text{ mA}; V_{GS} = 10\text{ V}$	R_{DSon}	typ. <	2,0 Ω 4,0 Ω
Transfer admittance $I_D = 500\text{ mA}; V_{DS} = 15\text{ V}; f = 1\text{ kHz}$	$ y_{fs} $	typ.	300 mS

MECHANICAL DATA

Fig. 1 SOT-89.

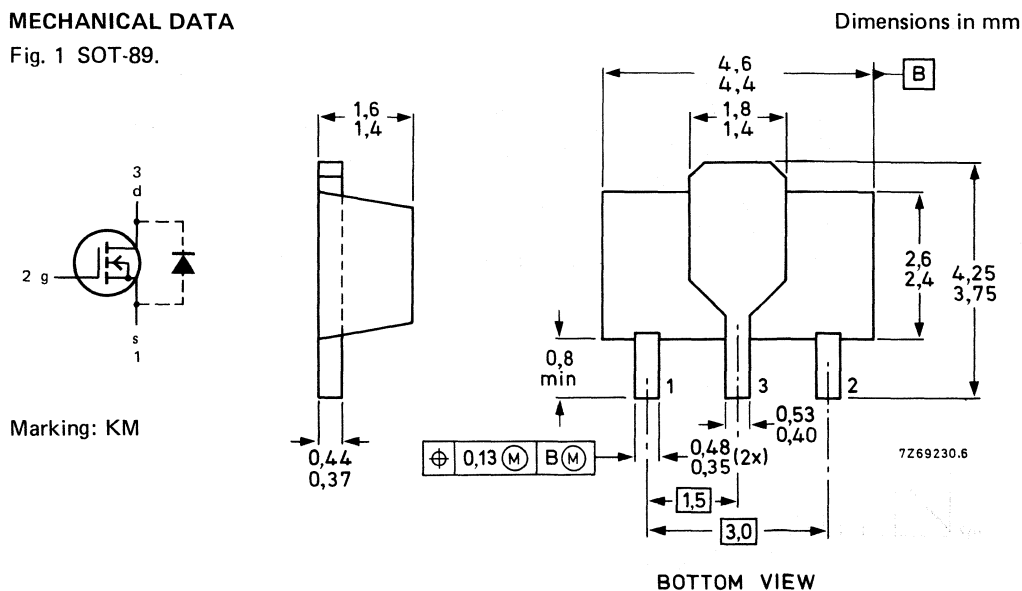

RATINGS

Limiting values in accordance with the Absolute Maximum System (IEC 134)

Drain-source voltage	V_{DS}	max.	80 V
Gate-source voltage (open drain)	V_{GS0}	max.	20 V
Drain current (d.c.)	I_D	max.	0,5 A
Drain current (peak)	I_{DM}	max.	1,0 A
Total power dissipation up to $T_{amb} = 25\text{ }^\circ\text{C}^*$	P_{tot}	max.	1 W
Storage temperature	T_{stg}		-65 to + 150 $^\circ\text{C}$
Junction temperature	T_j	max.	150 $^\circ\text{C}$

THERMAL RESISTANCE

From junction to ambient*	$R_{th\ j-a}$		125 K/W
---------------------------	---------------	--	---------

CHARACTERISTICS

$T_j = 25\text{ }^\circ\text{C}$ unless otherwise specified

Drain-source breakdown voltage $I_D = 100\ \mu\text{A}; V_{GS} = 0$	$V_{(BR)DS}$	>	80 V
Drain-source leakage current $V_{DS} = 60\text{ V}; V_{GS} = 0$	I_{DSS}	<	10 μA
Gate-source leakage current $V_{GS} = 20\text{ V}; V_{DS} = 0$	I_{GSS}	<	100 nA
Gate threshold voltage $I_D = 1\text{ mA}; V_{DS} = V_{GS}$	$V_{GS(th)}$	> <	1,5 V 3,5 V
Drain-source ON-resistance $I_D = 500\text{ mA}; V_{GS} = 10\text{ V}$	R_{DSon}	typ. <	2,0 Ω 4,0 Ω
Transfer admittance at $f = 1\text{ kHz}$ $I_D = 500\text{ mA}; V_{DS} = 15\text{ V}$	$ y_{fs} $	typ.	300 mS
Input capacitance at $f = 1\text{ MHz}$ $V_{DS} = 10\text{ V}; V_{GS} = 0$	C_{is}	typ.	45 pF
Output capacitance at $f = 1\text{ MHz}$ $V_{DS} = 10\text{ V}; V_{GS} = 0$	C_{os}	typ.	30 pF
Feedback capacitance at $f = 1\text{ MHz}$ $V_{DS} = 10\text{ V}; V_{GS} = 0$	C_{rs}	typ.	8 pF
Switching times (see Figs 2 and 3) $I_D = 500\text{ mA}; V_{DS} = 50\text{ V}; V_{GS} = 0\text{ to }10\text{ V}$	t_{on} t_{off}	< <	10 ns 15 ns

* Transistors mounted on a substrate with surface area of 2,5 cm² and thickness of 0,7 mm.

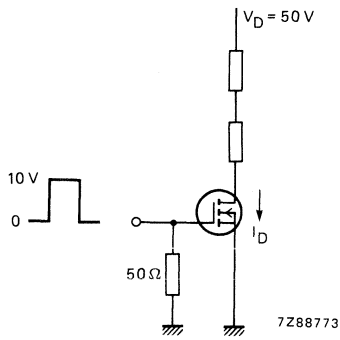

Fig. 2 Switching times test circuit.

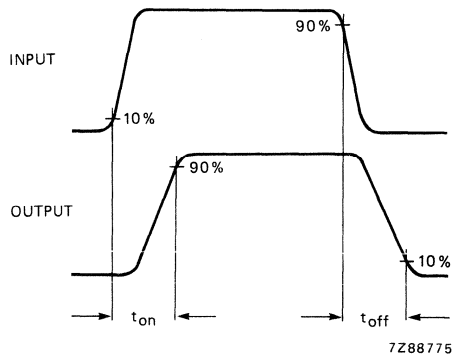

Fig. 3 Input and output waveforms.

RATINGS

Limiting values in accordance with the Absolute Maximum System (IEC 134)

Drain-source voltage	V_{DS}	max.	80 V
Drain-source voltage (non-repetitive peak; $t_p \leq 2$ ms)	$V_{DS(SM)}$	max.	100 V
Gate-source voltage (open drain)	V_{GS0}	max.	20 V
Drain current (d.c.)	I_D	max.	175 mA
Drain current (peak)	I_{DM}	max.	600 mA
Total power dissipation up to $T_{amb} = 25$ °C*	P_{tot}	max.	300 mW
Storage temperature range	T_{stg}		-65 to + 150 °C
Junction temperature	T_j	max.	150 °C

THERMAL RESISTANCE

From junction to ambient*	$R_{th\ j-a}$	=	430 K/W
---------------------------	---------------	---	---------

CHARACTERISTICS

$T_j = 25$ °C unless otherwise specified

Drain-source breakdown voltage $I_D = 100$ μ A; $V_{GS} = 0$	$V_{(BR)DS}$	>	80 V
Drain-source leakage current $V_{DS} = 60$ V; $V_{GS} = 0$	I_{DSS}	<	1,0 μ A
Gate-source leakage current $V_{GS} = 20$ V; $V_{DS} = 0$	I_{GSS}	<	100 nA
Gate-source cut-off voltage $I_D = 1$ mA; $V_{DS} = V_{GS}$	$V_{(P)GS}$	> <	1,5 V 3,5 V
Drain-source ON-resistance $I_D = 150$ mA; $V_{GS} = 5$ V	R_{DSon}	typ. <	7 Ω 10 Ω
Transfer admittance at $f = 1$ kHz $I_D = 175$ mA; $V_{DS} = 5$ V	$ y_{fs} $	typ.	150 mS
Input capacitance at $f = 1$ MHz $V_{DS} = 10$ V; $V_{GS} = 0$	C_{is}	typ.	15 pF
Output capacitance at $f = 1$ MHz $V_{DS} = 10$ V; $V_{GS} = 0$	C_{os}	typ.	13 pF
Feedback capacitance at $f = 1$ MHz $V_{DS} = 10$ V; $V_{GS} = 0$	C_{rs}	typ.	3 pF
Switching times (see Figs 2 and 3) $I_D = 175$ mA; $V_{DS} = 50$ V; $V_{GS} = 0$ to 10 V	t_{on}	typ. <	4 ns 10 ns
	t_{off}	typ. <	4 ns 10 ns

* Transistors mounted on a ceramic substrate of 7 mm x 5 mm x 0,7 mm.

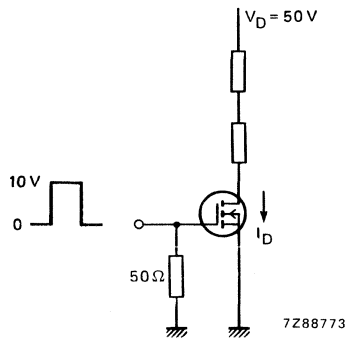

Fig. 2 Switching times test circuit.

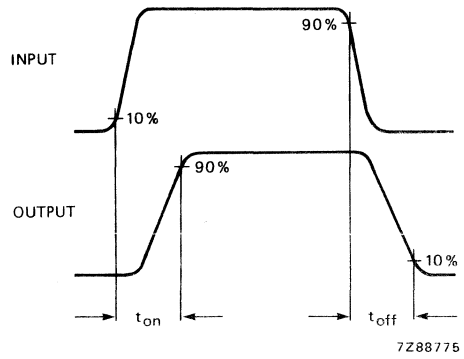

Fig. 3 Input and output waveforms.

N-CHANNEL VERTICAL D-MOS TRANSISTOR

N-channel vertical D-MOS transistor in SOT-89 envelope and designed for use as line current interrupter in telephone sets and for application in relay, high-speed and line-transformer drivers.

Features

- Direct interface to C-MOS, TTL, etc.
- High-speed switching
- No second breakdown

QUICK REFERENCE DATA

Drain-source voltage	V_{DS}	max.	200 V
Gate-source voltage (open drain)	V_{GSO}	max.	20 V
Drain current (d.c.)	I_D	max.	250 mA
Total power dissipation up to $T_{amb} = 25\text{ }^\circ\text{C}$	P_{tot}	max.	1 W
Drain-source ON-resistance $I_D = 250\text{ mA}; V_{GS} = 10\text{ V}$	R_{DSon}	typ.	6 Ω
		<	12 Ω
Transfer admittance $I_D = 250\text{ mA}; V_{DS} = 15\text{ V}; f = 1\text{ kHz}$	$ y_{fs} $	typ.	250 mS

MECHANICAL DATA

Dimensions in mm

Fig. 1 SOT-89.

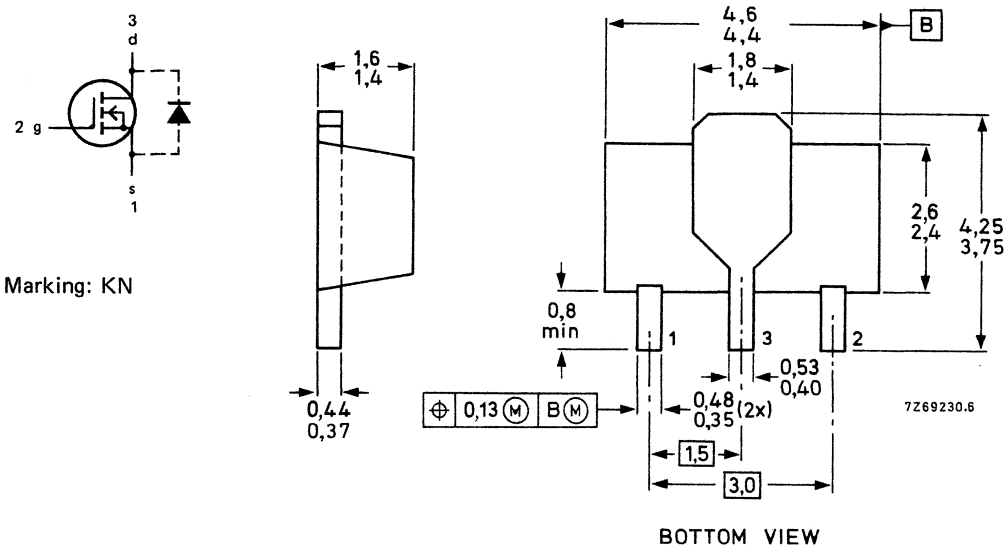

RATINGS

Limiting values in accordance with the Absolute Maximum System (IEC 134)

Drain-source voltage	V_{DS}	max.	200 V
Gate-source voltage (open drain)	V_{GSO}	max.	20 V
Drain current (d.c.)	I_D	max.	250 mA
Drain current (peak)	I_{DM}	max.	800 mA
Total power dissipation up to $T_{amb} = 25\text{ }^\circ\text{C}^*$	P_{tot}	max.	1 W
Storage temperature	T_{stg}		-65 to + 150 $^\circ\text{C}$
Junction temperature	T_j	max.	150 $^\circ\text{C}$

THERMAL RESISTANCE

From junction to ambient	$R_{th\ j-a}$	=	125 K/W
--------------------------	---------------	---	---------

CHARACTERISTICS

$T_j = 25\text{ }^\circ\text{C}$ unless otherwise specified

Drain-source breakdown voltage $I_D = 100\text{ }\mu\text{A}; V_{GS} = 0$	$V_{(BR)DS}$	>	200 V
Drain-source leakage current $V_{DS} = 160\text{ V}; V_{GS} = 0$	I_{DSS}	<	10 μA
Gate-source leakage current $V_{GS} = 20\text{ V}; V_{DS} = 0$	I_{GSS}	<	100 nA
Gate threshold voltage $I_D = 1\text{ mA}; V_{DS} = V_{GS}$	$V_{GS(th)}$	> <	0,8 V 2,8 V
Drain-source ON-resistance $I_D = 250\text{ mA}; V_{GS} = 10\text{ V}$	R_{DSon}	typ. <	6 Ω 12 Ω
Transfer admittance at $f = 1\text{ kHz}$ $I_D = 250\text{ mA}; V_{DS} = 15\text{ V}$	$ y_{fs} $	typ.	250 mS
Input capacitance at $f = 1\text{ MHz}$ $V_{DS} = 10\text{ V}; V_{GS} = 0$	C_{is}	typ.	70 pF
Output capacitance at $f = 1\text{ MHz}$ $V_{DS} = 10\text{ V}; V_{GS} = 0$	C_{os}	typ.	20 pF
Feedback capacitance at $f = 1\text{ MHz}$ $V_{DS} = 10\text{ V}; V_{GS} = 0$	C_{rs}	typ.	5 pF
Switching times (see Figs 2 and 3) $I_D = 250\text{ mA}; V_{DS} = 50\text{ V}; V_{GS} = 0\text{ to }10\text{ V}$	t_{on}	typ. <	4 ns 10 ns
	t_{off}	typ. <	15 ns 25 ns

* Transistor mounted on a ceramic substrate with area of 2,5 cm² and thickness of 0,7 mm.

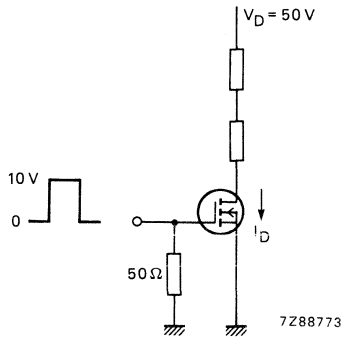

Fig. 2 Switching times test circuit.

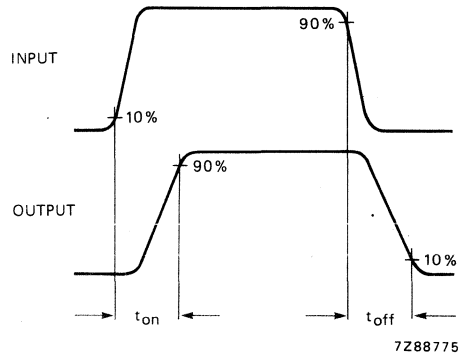

Fig. 3 Input and output waveforms.

N-CHANNEL VERTICAL D-MOS TRANSISTOR

N-channel enhancement mode vertical D-MOS transistor in SOT-89 envelope and designed for use as Surface Mounted Device (SMD) in thin and thick-film circuits for application with relay, high-speed and line-transformer drivers.

Features

- Direct interface to C-MOS, TTL, etc.
- High-speed switching
- No second breakdown

QUICK REFERENCE DATA

Drain source voltage	V_{DS}	max.	180 V
Drain-source voltage (non-repetitive peak; $t_p \leq 2$ ms)	$V_{DS(SM)}$	max.	200 V
Gate-source voltage (open drain)	V_{GSO}	max.	20 V
Drain current (d.c.)	I_D	max.	300 mA
Total power dissipation up to $T_{amb} = 25$ °C	P_{tot}	max.	1 W
Drain-source ON-resistance $I_D = 15$ mA; $V_{GS} = 3$ V	R_{DSon}	typ. <	7 Ω 10 Ω
Transfer admittance $I_D = 300$ mA; $V_{DS} = 15$ V; $f = 1$ kHz	$ y_{fs} $	typ.	250 mS

MECHANICAL DATA

Fig. 1 SOT-89.

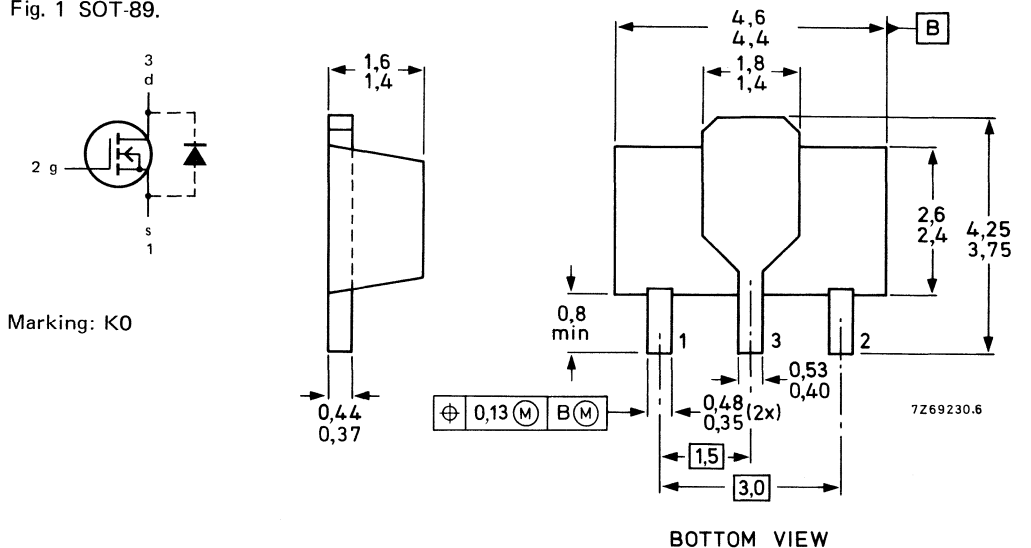

RATINGS

Limiting values in accordance with the Absolute Maximum System (IEC 134)

Drain-source voltage	V_{DS}	max.	180 V
Drain-source voltage (non-repetitive peak; $t_p \leq 2$ ms)	$V_{DS(SM)}$	max.	200 V
Gate-source voltage (open drain)	V_{GSO}	max.	20 V
Drain current (d.c.)	I_D	max.	300 mA
Drain current (peak)	I_{DM}	max.	800 mA
Total power dissipation up to $T_{amb} = 25$ °C*	P_{tot}	max.	1 W
Storage temperature	T_{stg}		-65 to +150 °C
Junction temperature	T_j	max.	150 °C

THERMAL RESISTANCE

From junction to ambient*	$R_{th\ j-a}$	=	125 K/W
---------------------------	---------------	---	---------

CHARACTERISTICS

$T_j = 25$ °C unless otherwise specified

Drain-source breakdown voltage

$I_D = 100 \mu A; V_{GS} = 0$

$V_{(BR)DS}$	>	180 V
--------------	---	-------

Drain-source leakage current

$V_{DS} = 120 V; V_{GS} = 0$

I_{DSS}	<	10 μA
-----------	---	------------

Gate-source leakage current

$V_{GS} = 20 V; V_{DS} = 0$

I_{GSS}	<	100 nA
-----------	---	--------

Gate threshold voltage

$I_D = 100 \mu A; V_{DS} = V_{GS}$

$V_{GS(th)}$	>	0,7 V
	<	2,7 V

Drain-source ON-resistance

$I_D = 15 mA; V_{GS} = 3 V$

R_{DSon}	typ.	7 Ω
	<	10 Ω

$I_D = 300 mA; V_{GS} = 10 V$

R_{DSon}	typ.	6 Ω
------------	------	------------

Transfer admittance at $f = 1$ kHz

$I_D = 300 mA; V_{DS} = 15 V$

$ y_{fs} $	typ.	250 mS
------------	------	--------

Input capacitance at $f = 1$ MHz

$V_{DS} = 10 V; V_{GS} = 0$

C_{is}	typ.	50 pF
----------	------	-------

Output capacitance at $f = 1$ MHz

$V_{DS} = 10 V; V_{GS} = 0$

C_{os}	typ.	20 pF
----------	------	-------

Feedback capacitance at $f = 1$ MHz

$V_{DS} = 10 V; V_{GS} = 0$

C_{rs}	typ.	6 pF
----------	------	------

Switching times (see Figs 2 and 3)

$I_D = 300 mA; V_{DS} = 50 V; V_{GS} = 0$ to 10 V

t_{on}	<	10 ns
t_{off}	<	15 ns

* Transistors mounted on a ceramic substrate with area of 2,5 cm² and thickness of 0,7 mm.

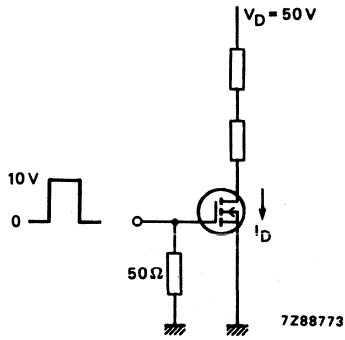

Fig. 2 Switching times test circuit.

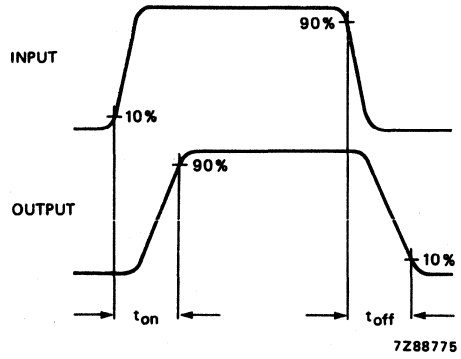

Fig. 3 Input and output waveforms.

DEVELOPMENT DATA

This data sheet contains advance information and specifications are subject to change without notice.

BST120

P-CHANNEL VERTICAL D-MOS TRANSISTOR

P-channel vertical D-MOS transistor in SOT-89 envelope and intended for use in relay, high-speed and line-transformer drivers, using SMD technology.

Features

- Very low R_{DSon}
- Direct interface to C-MOS
- High-speed switching
- No second breakdown

QUICK REFERENCE DATA

Drain-source voltage	$-V_{DS}$	max.	60 V
Gate-source voltage (open drain)	$-V_{GSO}$	max.	20 V
Drain current (d.c.)	$-I_D$	max.	0,3 A
Total power dissipation up to $T_{amb} = 25\text{ }^\circ\text{C}$	P_{tot}	max.	1 W
Drain-source ON-resistance $-I_D = 200\text{ mA}; -V_{GS} = 10\text{ V}$	R_{DSon}	typ. max.	4,5 Ω 6 Ω
Transfer admittance $-I_D = 200\text{ mA}; -V_{DS} = 15\text{ V}; f = 1\text{ kHz}$	$ y_{fs} $	typ.	200 mS

MECHANICAL DATA

Dimensions in mm

Fig. 1 SOT-89.

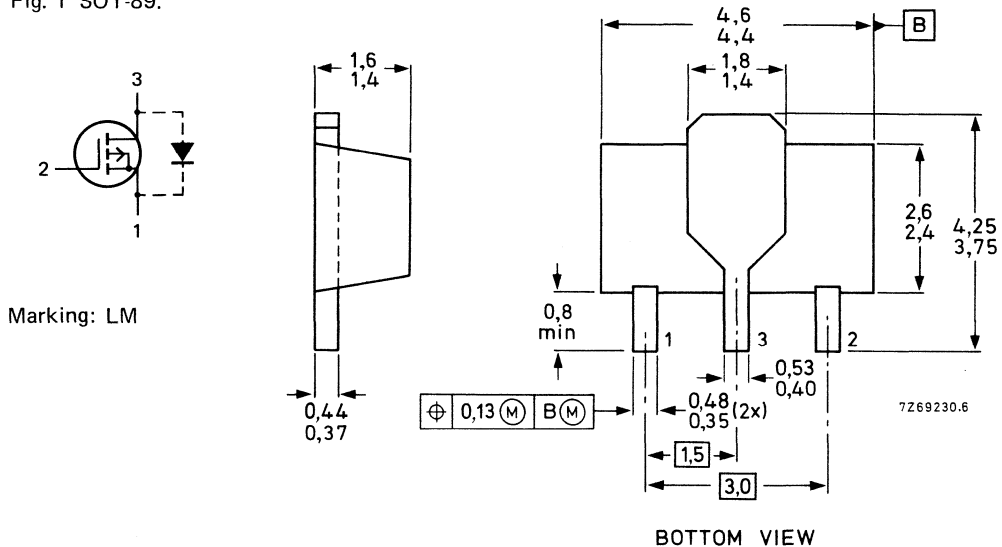

Marking: LM

RATINGS

Limiting values in accordance with the Absolute Maximum System (IEC 134)

Drain-source voltage	$-V_{DS}$	max.	60 V
Gate-source voltage (open drain)	$-V_{GSO}$	max.	20 V
Drain current (d.c.)	$-I_D$	max.	0,3 A
Drain current (peak)	$-I_{DM}$	max.	0,8 A
Total power dissipation up to $T_{amb} = 25\text{ }^\circ\text{C}^*$	P_{tot}	max.	1 W
Storage temperature	T_{stg}	-65 to +	150 $^\circ\text{C}$
Junction temperature	T_j	max.	150 $^\circ\text{C}$

THERMAL RESISTANCE

From junction to ambient*	$R_{th\ j-a}$	=	125 K/W
---------------------------	---------------	---	---------

CHARACTERISTICS

$T_j = 25\text{ }^\circ\text{C}$ unless otherwise specified

Drain-source breakdown voltage $-I_D = 100\ \mu\text{A}; -V_{GS} = 0$	$-V_{(BR)DS}$	>	60 V
Drain-source leakage current $-V_{DS} = 45\text{ V}; V_{GS} = 0$	$-I_{DSS}$	<	10 μA
Gate-source leakage current $-V_{GS} = 20\text{ V}; V_{DS} = 0$	$-I_{GSS}$	<	100 nA
Gate threshold voltage $-I_D = 1\text{ mA}; V_{DS} = V_{GS}$	$-V_{GS(th)}$	> <	1,5 V 3,5 V
Drain-source ON-resistance $-I_D = 200\text{ mA}; -V_{GS} = 10\text{ V}$	R_{DSon}	typ. <	4,5 Ω 6 Ω
Transfer admittance at $f = 1\text{ kHz}$ $-I_D = 200\text{ mA}; -V_{DS} = 15\text{ V}$	$ y_{fs} $	typ.	200 mS
Input capacitance at $f = 1\text{ MHz}$ $-V_{DS} = 10\text{ V}; V_{GS} = 0$	C_{is}	typ.	55 pF
Output capacitance at $f = 1\text{ MHz}$ $-V_{DS} = 10\text{ V}; V_{GS} = 0$	C_{os}	typ.	30 pF
Feedback capacitance at $f = 1\text{ MHz}$ $-V_{DS} = 10\text{ V}; V_{GS} = 0$	C_{rs}	typ.	8 pF
Switching times (see Figs 2 and 3) $-I_D = 200\text{ mA}; -V_{DS} = 50\text{ V}; -V_{GS} = 0\text{ to }10\text{ V}$	t_{on} t_{off}	typ. typ.	4 ns 20 ns

* Transistor mounted on a ceramic substrate: area = 2,5 cm² and thickness = 0,7 mm.

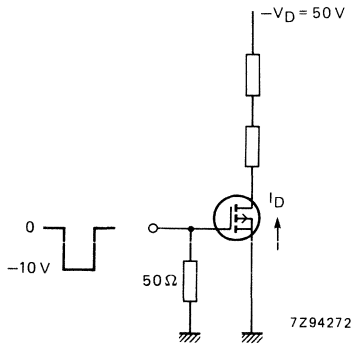

Fig. 2 Switching time test circuit.

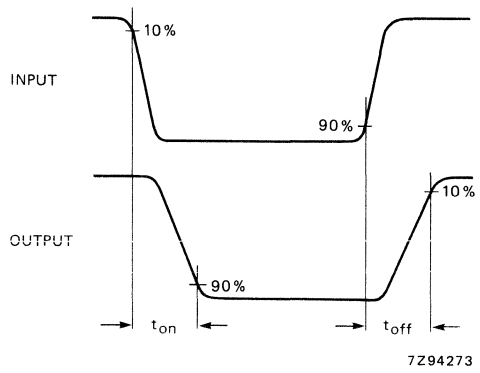

Fig. 3 Input and output waveforms.

DEVELOPMENT DATA

DEVELOPMENT DATA

This data sheet contains advance information and specifications are subject to change without notice.

BST122

P-CHANNEL VERTICAL D-MOS TRANSISTOR

P-channel vertical D-MOS transistor in SOT-89 envelope and intended for use in relay, high-speed and line-transformer drivers, using SMD-technology.

Features

- Very low R_{DSon}
- Direct interface to C-MOS, TTL
- High-speed switching
- No second breakdown

QUICK REFERENCE DATA

Drain-source voltage	$-V_{DS}$	max.	50 V
Gate-source voltage (open drain)	$-V_{GS0}$	max.	20 V
Drain current (d.c.)	$-I_D$	max.	0,25 A
Total power dissipation up to $T_{amb} = 25\text{ }^{\circ}\text{C}$	P_{tot}	max.	1 W
Drain-source ON-resistance $-I_D = 200\text{ mA}; -V_{GS} = 10\text{ V}$	R_{DSon}	typ.	7,5 Ω
		max.	10 Ω
Transfer admittance $-I_D = 200\text{ mA}; -V_{DS} = 15\text{ V}; f = 1\text{ kHz}$	$ y_{fs} $	typ.	125 mS

MECHANICAL DATA

Fig. 1 SOT-89.

Dimensions in mm

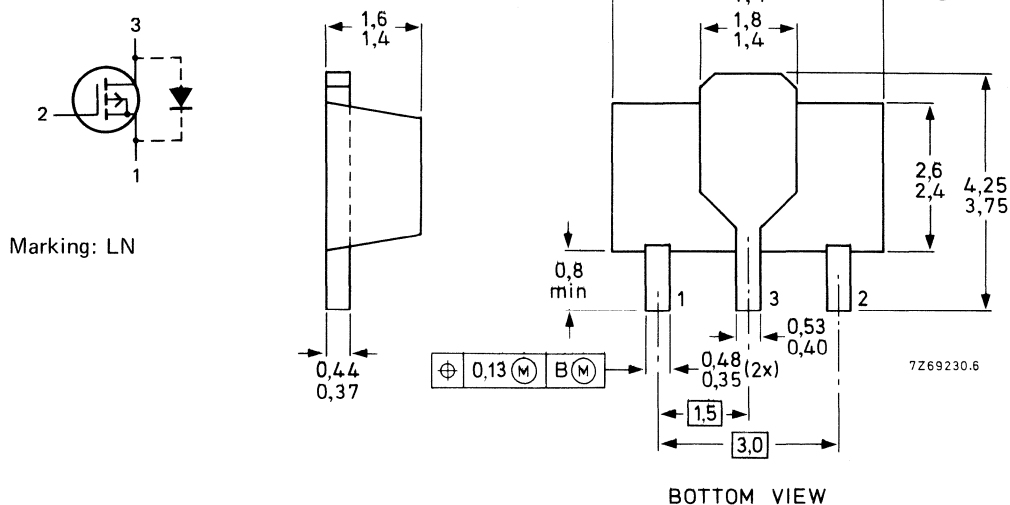

RATINGS

Limiting values in accordance with the Absolute Maximum System (IEC 134)

Drain-source voltage	$-V_{DS}$	max.	50 V
Gate-source voltage (open drain)	$-V_{GSO}$	max.	20 V
Drain current (d.c.)	$-I_D$	max.	0,25 A
Drain current (peak)	$-I_{DM}$	max.	0,5 A
Total power dissipation up to $T_{amb} = 25\text{ }^\circ\text{C}$	P_{tot}	max.	1 W
Storage temperature	T_{stg}		$-65\text{ to }+150\text{ }^\circ\text{C}$
Junction temperature	T_j	max.	150 $^\circ\text{C}$

THERMAL RESISTANCE

From junction to ambient*	$R_{th\ j-a}$	=	125 K/W
---------------------------	---------------	---	---------

CHARACTERISTICS

$T_j = 25\text{ }^\circ\text{C}$ unless otherwise specified

Drain-source breakdown voltage $-I_D = 100\text{ }\mu\text{A}; -V_{GS} = 0$	$-V_{(BR)DS}$	>	50 V
Drain-source leakage current $-V_{DS} = 1\text{ V}; V_{GS} = 0$	$-I_{DSS}$	<	10 μA
Gate-source leakage current $-V_{GS} = 20\text{ V}; V_{DS} = 0$	$-I_{GSS}$	<	100 nA
Gate threshold voltage $-I_D = 1\text{ mA}; V_{DS} = V_{GS}$	$-V_{GS(th)}$	> <	1,5 V 3,5 V
Drain-source ON-resistance $-I_D = 200\text{ mA}; -V_{GS} = 10\text{ V}$	R_{DSon}	typ. <	7,5 Ω 10 Ω
Transfer admittance at $f = 1\text{ kHz}$ $-I_D = 200\text{ mA}; -V_{DS} = 15\text{ V}$	$ y_{fs} $	typ.	125 mS
→ Input capacitance at $f = 1\text{ MHz}$ $-V_{DS} = 10\text{ V}; V_{GS} = 0$	C_{is}	typ.	30 pF
→ Output capacitance at $f = 1\text{ MHz}$ $-V_{DS} = 10\text{ V}; V_{GS} = 0$	C_{os}	typ.	20 pF
→ Feedback capacitance at $f = 1\text{ MHz}$ $-V_{DS} = 10\text{ V}; V_{GS} = 0$	C_{rs}	typ.	5 pF
→ Switching times (see Figs 2 and 3) $-I_D = 200\text{ mA}; -V_{DS} = 40\text{ V}; -V_{GS} = 0\text{ to }10\text{ V}$	t_{on} t_{off}	typ. typ.	4 ns 10 ns

* Transistor mounted on a ceramic substrate: area = 2,5 cm²; thickness = 0,7 mm.

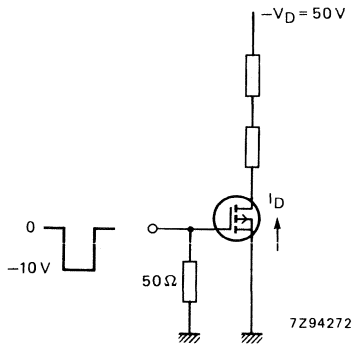

Fig. 2 Switching times test circuit.

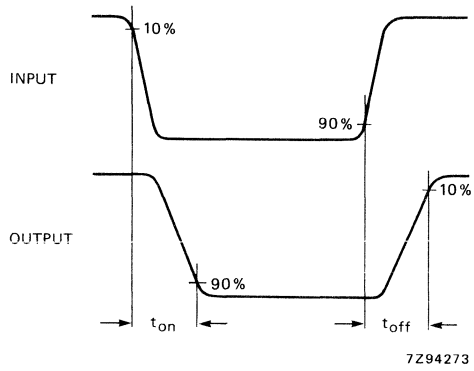

Fig. 3 Input and output waveforms.

DEVELOPMENT DATA

SILICON PLANAR EPITAXIAL TRANSISTORS

- High-speed switching

N-P-N transistor in a microminiature plastic envelope. It is intended for very high-speed saturated switching in thick and thin-film circuits.

QUICK REFERENCE DATA

Collector-base voltage (open emitter)	V_{CBO}	max.	20 V
Collector-emitter voltage ($V_{BE} = 0$)	V_{CES}	max.	20 V
Collector-emitter voltage (open base)	V_{CEO}	max.	12 V
Collector current (peak value)	I_{CM}	max.	200 mA
Total power dissipation up to $T_{amb} = 65\text{ }^{\circ}\text{C}$	P_{tot}	max.	250 mW
Junction temperature	T_j	max.	175 $^{\circ}\text{C}$
D.C. current gain			
$I_C = 10\text{ mA}; V_{CE} = 1\text{ V}$	h_{FE}		40 to 120
$I_C = 50\text{ mA}; V_{CE} = 1\text{ V}$	h_{FE}	>	25
Transition frequency at $f = 100\text{ MHz}$			
$I_C = 10\text{ mA}; V_{CE} = 10\text{ V}$	f_T	>	400 MHz
		typ.	500 MHz
Storage time			
$I_C = I_B = -I_{BM} = 10\text{ mA}$	t_s	<	13 ns

MECHANICAL DATA

Fig. 1 SOT-23.

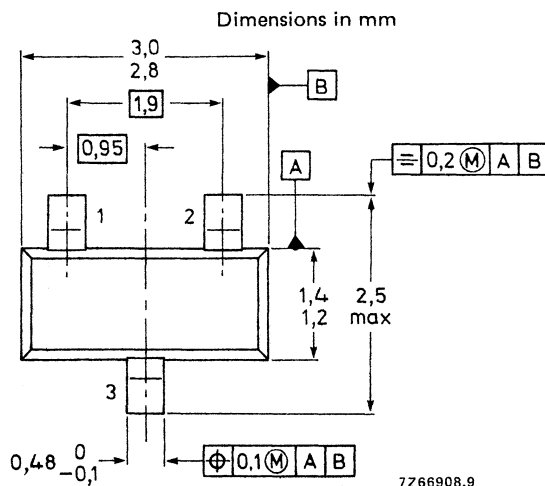
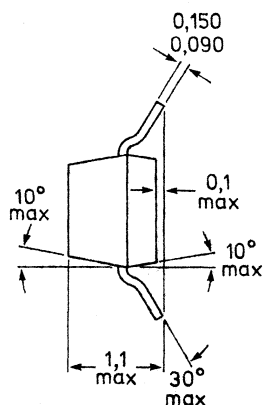

Marking code

BSV52 = B2

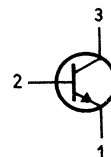

BSV52R = B4

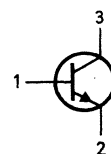

R-types are available on request.

See also *Soldering recommendations*.

RATINGS

Limiting values in accordance with the Absolute Maximum System (IEC 134)

Collector-base voltage (open emitter) See Fig. 4	V_{CBO}	max.	20 V
Collector-emitter voltage ($V_{BE} = 0$) See Fig. 4	V_{CES}	max.	20 V
Collector-emitter voltage (open base) $I_C = 10$ mA (see Fig. 4)	V_{CEO}	max.	12 V
Emitter-base voltage (open collector) See Fig. 4	V_{EBO}	max.	5 V
Collector current (d.c.)	I_C	max.	100 mA
Collector current (peak value)	I_{CM}	max.	200 mA
Total power dissipation up to $T_{amb} = 65$ °C **	P_{tot}	max.	250 mW
Storage temperature	T_{stg}		-65 to + 175 °C
Junction temperature	T_j	max.	175 °C

THERMAL CHARACTERISTICS*

$$T_j = P \times (R_{th\ j-t} + R_{th\ t-s} + R_{th\ s-a}) + T_{amb}$$

Thermal resistance

From junction to tab	$R_{th\ j-t}$	=	60 K/W
From tab to soldering points	$R_{th\ t-s}$	=	280 K/W
From soldering points to ambient**	$R_{th\ s-a}$	=	90 K/W

CHARACTERISTICS $T_j = 25$ °C unless otherwise specified

Collector cut-off current

$I_E = 0; V_{CB} = 10$ V

$I_{CBO} < 100$ nA

$I_E = 0; V_{CB} = 10$ V; $T_j = 125$ °C

$I_{CBO} < 5$ μ A

Saturation voltages

$I_C = 10$ mA; $I_B = 300$ μ A

$V_{CEsat} < 300$ mV

$I_C = 10$ mA; $I_B = 1$ mA

$V_{CEsat} < 250$ mV

$V_{BEsat} 700$ to 850 mV

$I_C = 50$ mA; $I_B = 5$ mA

$V_{CEsat} < 400$ mV

$V_{BEsat} < 1200$ mV

D.C. current gain

$I_C = 1$ mA; $V_{CE} = 1$ V

$h_{FE} > 25$

$I_C = 10$ mA; $V_{CE} = 1$ V

$h_{FE} 40$ to 120

$I_C = 50$ mA; $V_{CE} = 1$ V

$h_{FE} > 25$

Transition frequency at $f = 100$ MHz

$I_C = 10$ mA; $V_{CE} = 10$ V

$f_T > 400$ MHz
typ. 500 MHz

* See *Thermal characteristics*.

** Mounted on a ceramic substrate of 8 mm x 10 mm x 0,7 mm.

Collector capacitance at $f = 1 \text{ MHz}$

$$I_E = I_e = 0; V_{CB} = 5 \text{ V}$$

$$C_c < 4 \text{ pF}$$

Emitter capacitance at $f = 1 \text{ MHz}$

$$I_C = I_c = 0; V_{EB} = 1 \text{ V}$$

$$C_e < 4,5 \text{ pF}$$

Switching times

Storage time $I_C = I_B = -I_{BM} = 10 \text{ mA}$

$$t_s < 13 \text{ ns}$$

Turn on time when switched from

$-V_{BE} = 1,5 \text{ V}$ to $I_C = 10 \text{ mA}; I_B = 3 \text{ mA}$

$$t_{on} < 12 \text{ ns}$$

Turn off time when switched from

$I_C = 10 \text{ mA}; I_B = 3 \text{ mA}$

to cut-off with $-I_{BM} = 1,5 \text{ mA}$

$$t_{off} < 18 \text{ ns}$$

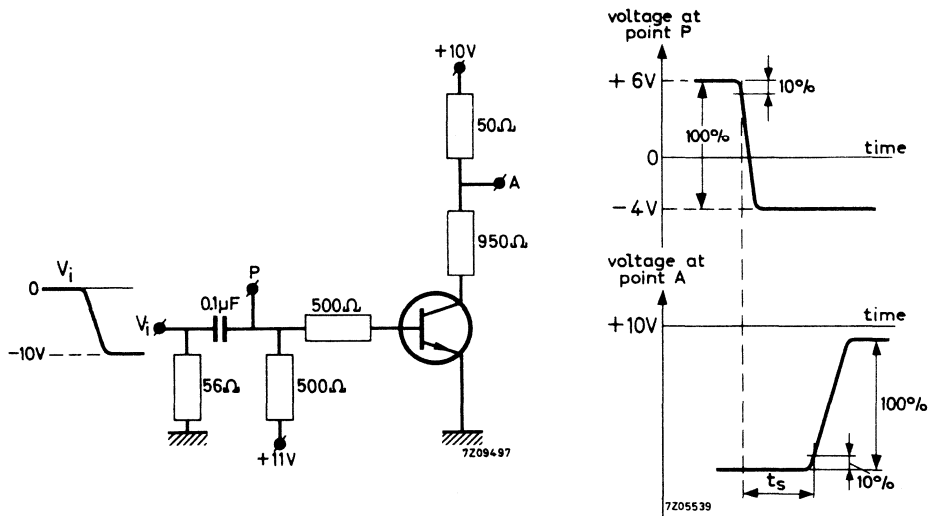

Fig. 2 Test circuit and waveform storage time.

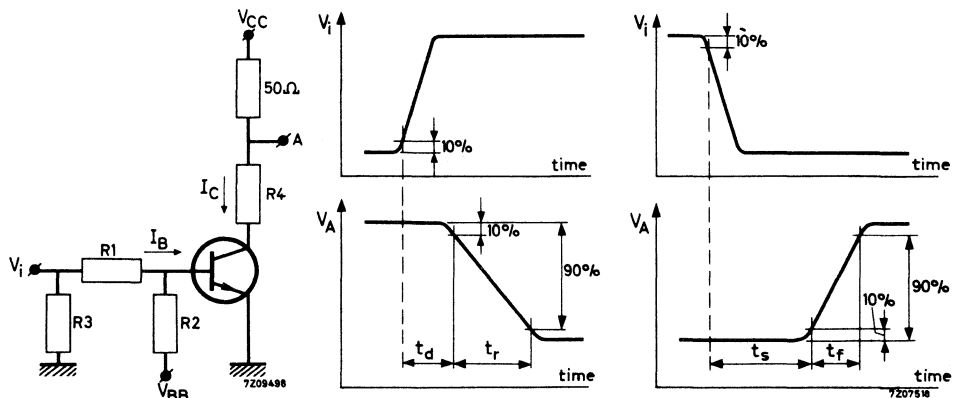

Fig. 3 Test circuit and waveforms turn on and turn off time.

Pulse generator:

Rise time $t_r < 1 \text{ ns}$
 Pulse duration $t > 300 \text{ ns}$
 Duty cycle $\delta < 0,02$
 Source impedance $R_S = 50 \Omega$

Oscilloscope:

Input impedance $R_i = 50 \Omega$
 Rise time $t_r < 1 \text{ ns}$

I_C mA	I_B mA	$-I_{BM}$ mA	V_{CC} V	$R_1; R_2$ k Ω	R_3 Ω	R_4 Ω	turn on time			turn off time	
							$-V_{BB}$ V	$-V_{BE}$ V	V_i V	V_{BB} V	$-V_i$ V
10	3	1,5	3	3,3	50	220	3,0	1,5	15	12,0	15

$-I_{BM}$ is the reverse current that can flow during switching off. The indicated $-I_{BM}$ is determined and limited by the applied cut-off voltage and series resistance.

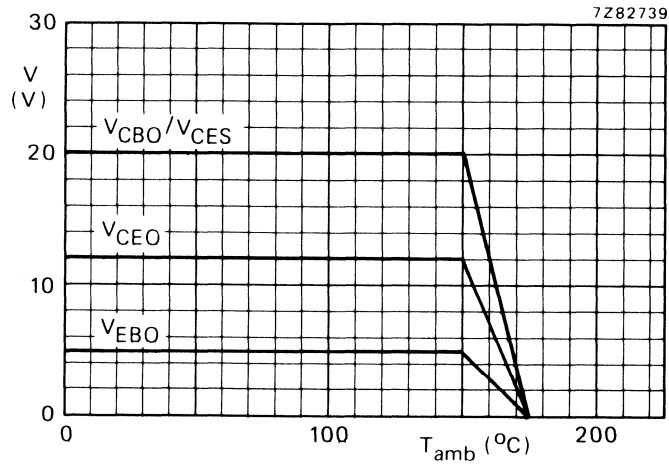

Fig. 4 Voltage derating curves.

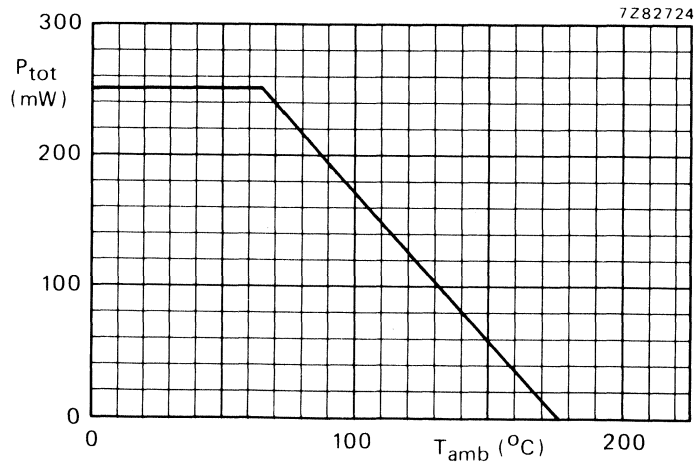

Fig. 5 Power derating curve.

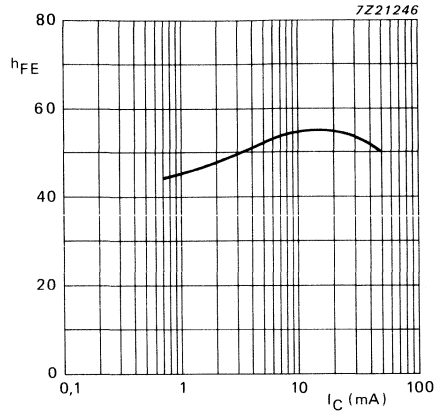

Fig. 6. $V_{CE} = 1$ V; $T_j = 25$ °C; typical values.

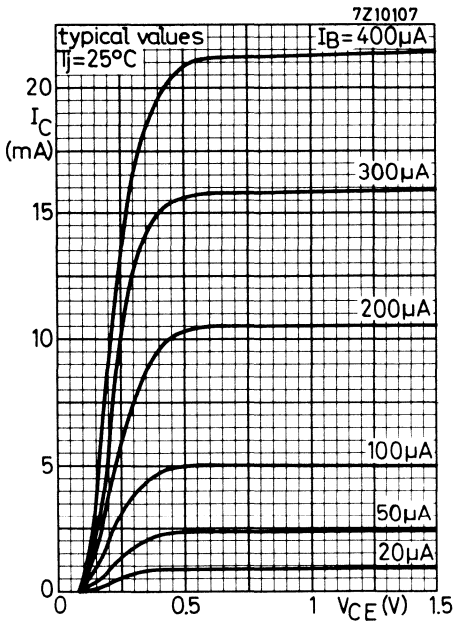

Fig. 7.

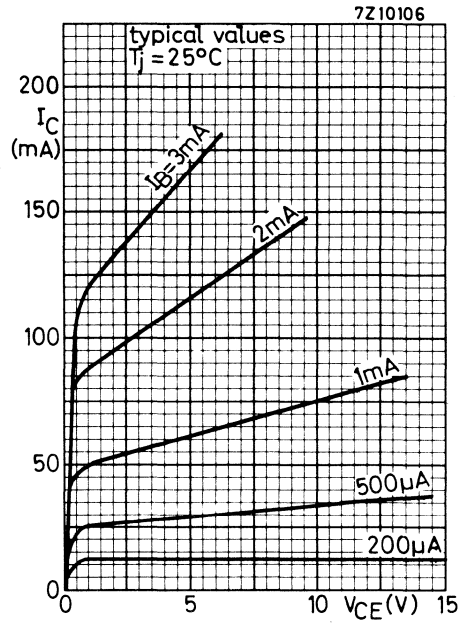

Fig. 8.

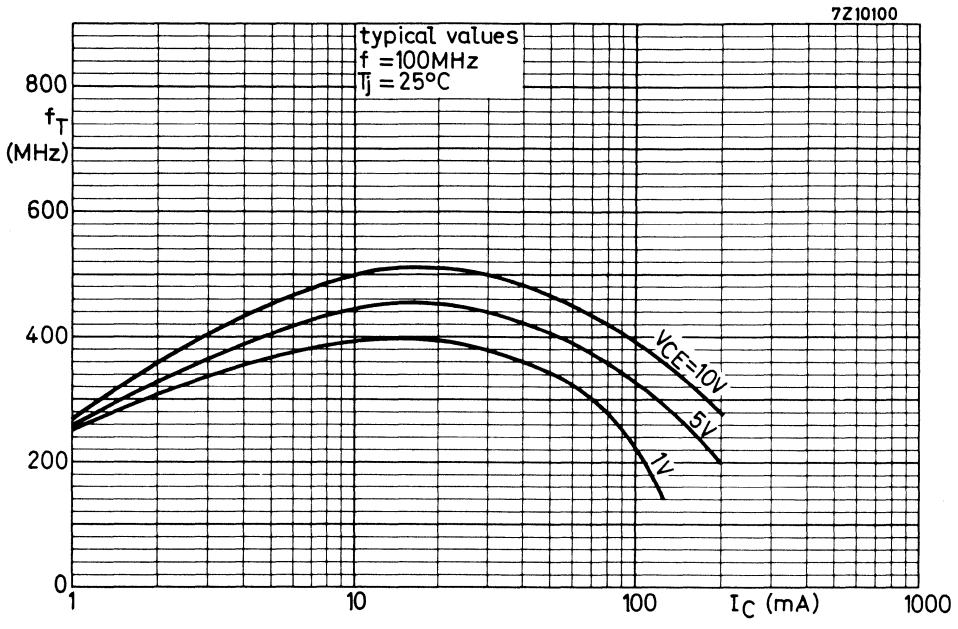

Fig. 9.

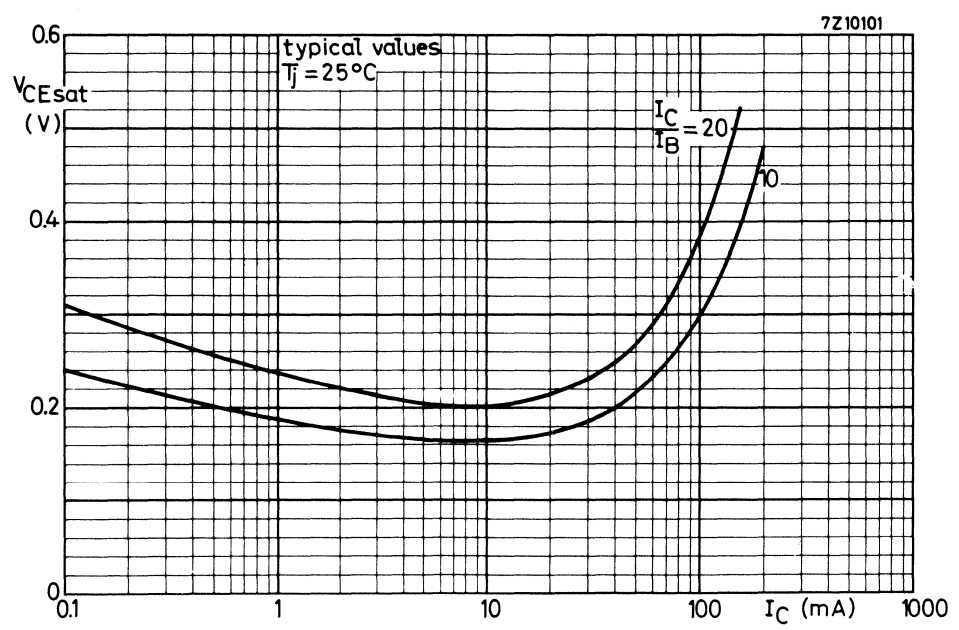

Fig. 10.

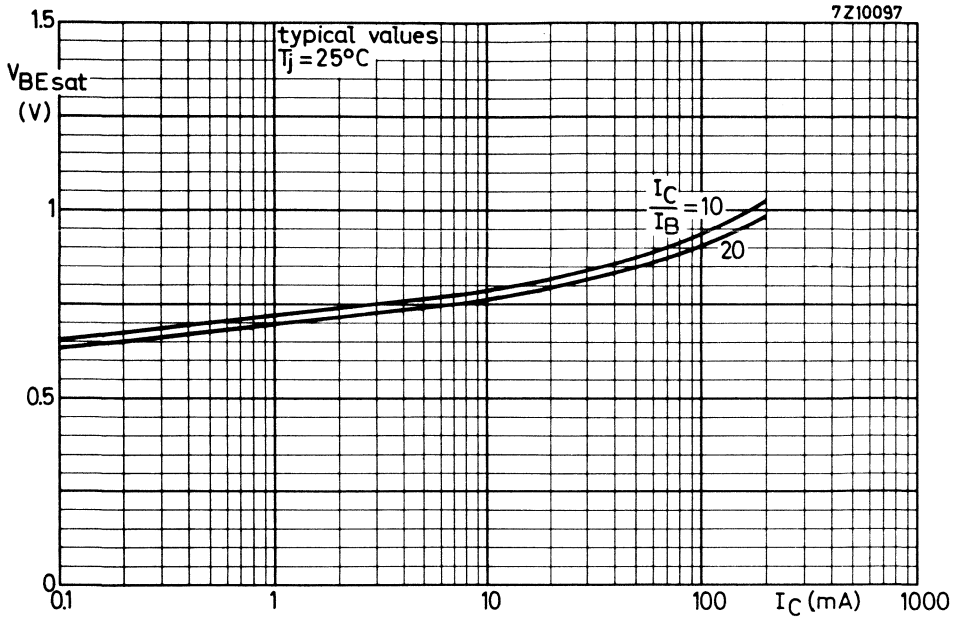

Fig. 11.

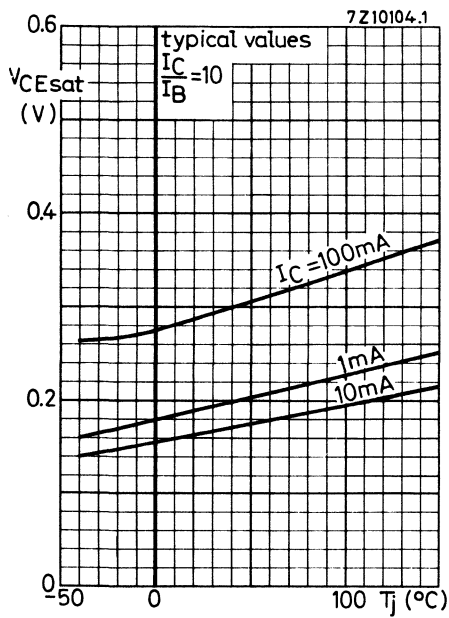

Fig. 12.

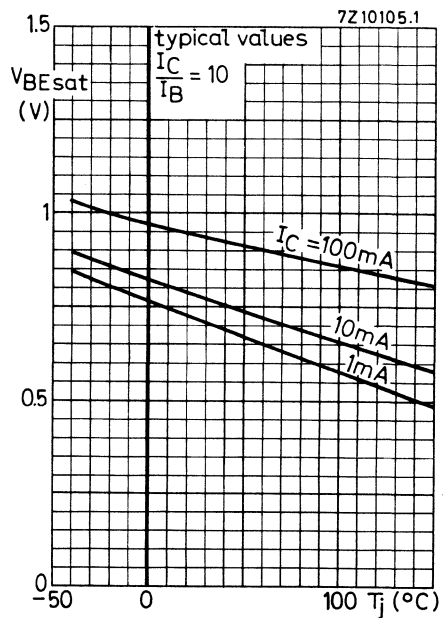

Fig. 13.

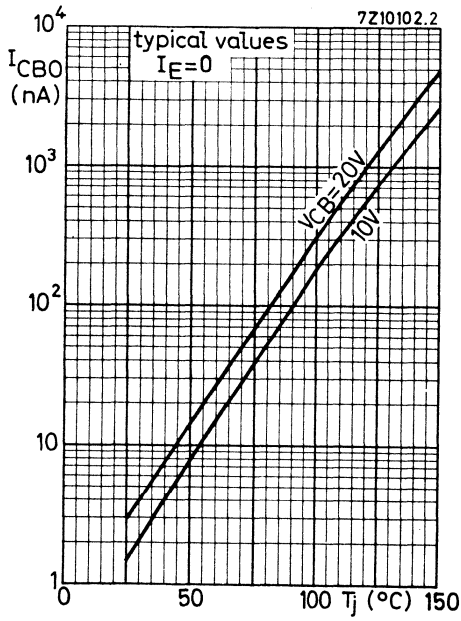

Fig. 14.

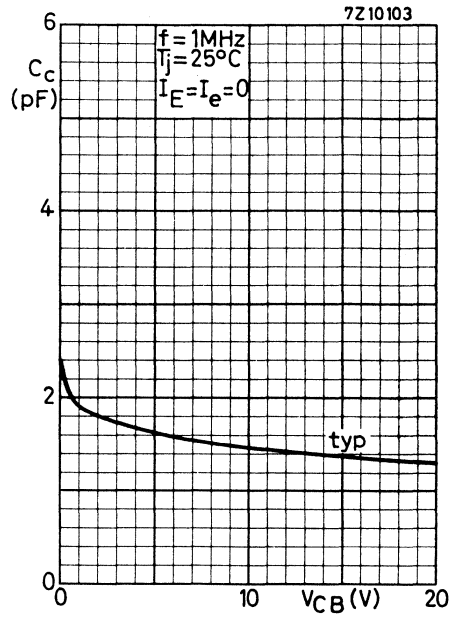

Fig. 15.

DEVELOPMENT DATA

This data sheet contains advance information and specifications are subject to change without notice.

BYD17 SERIES

CONTROLLED AVALANCHE RECTIFIER DIODES

Rectifier diodes in hermetically sealed leadless SMID* envelopes and intended for general purpose rectifier applications.

The device is capable of absorbing reverse transient energy.

QUICK REFERENCE DATA

			BYD17D	G	J	K	M	
Crest working voltage	V_{RWM}	max.	200	400	600	800	1000	V
Reverse avalanche breakdown voltage	$V_{(BR)R}$	>	225	450	650	900	1100	V
		<	1600	1600	1600	1600	1600	V
Average forward current	$I_{F(AV)}$	max.			1,5			A
Non-repetitive peak forward current	I_{FSM}	max.			20			A
Non-repetitive peak reverse power dissipation	P_{RSM}	max.			0,4			kW
Junction temperature	T_j	max.			175			°C

MECHANICAL DATA

Dimensions in mm

Fig. 1 SOD-87.

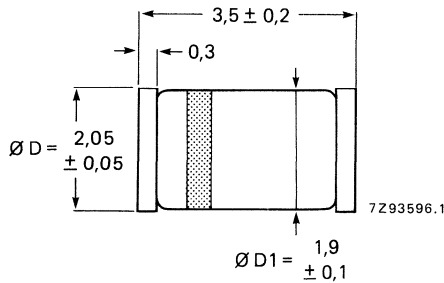

* Surface-mounted implosion diode.

RATINGS

Limiting values in accordance with the Absolute Maximum System (IEC 134)

		BYD17D					G	J	K	M
Crest working reverse voltage	V_{RWM}	max.	200	400	600	800	1000	V		
Continuous reverse voltage	V_R	max.	200	400	600	800	1000	V		
Average forward current (averaged over any 20 ms period)										
$T_{tp} = 105\text{ }^\circ\text{C}$; lead length 10 mm	$I_{F(AV)}$	max.			1,5				A	
$T_{amb} = 65\text{ }^\circ\text{C}$; p.c. board mounting	$I_{F(AV)}$	max.			0,6				A	
Repetitive peak forward current										
$T_{tp} = 55\text{ }^\circ\text{C}$; $f = 50\text{ Hz}$; $a = 3$; (inclusive derating for T_j max at $V_{RRM} = 1000\text{ V}$)	I_{FRM}	max.			5,5				A	
Non-repetitive peak forward current										
$t = 10\text{ ms}$, half-sine wave; $T_j = T_{j\text{ max}}$ prior to surge; $V_R = V_{RWM\text{ max}}$	I_{FSM}	max.			20				A	
Non-repetitive peak reverse power dissipation; $t = 20\text{ }\mu\text{s}$ (half-sine wave); $T_j = T_{j\text{ max}}$ prior to surge										
	P_{RSM}	max.			0,4				kW	
Non-repetitive peak reverse avalanche energy; $I_R = 0,34\text{ A}$; $T_j = T_{j\text{ max}}$ prior to surge; with inductive load switched off										
	E_{RSM}	max.			7				mJ	
Storage temperature	T_{stg}		-65 to + 175						$^\circ\text{C}$	
Junction temperature	T_j	max.			175				$^\circ\text{C}$	

THERMAL RESISTANCE

Influence of mounting method

- Thermal resistance from junction to tie-point at a lead length of 10 mm
 $R_{th\ j\text{-tp}} =$ 30 K/W
- Thermal resistance from junction to ambient; device mounted on an 1,5 mm thick epoxy-glass printed circuit board; Cu-thickness $\geq 40\text{ }\mu\text{m}$ (see Fig. 2)
 $R_{th\ j\text{-a}} =$ 150 K/W

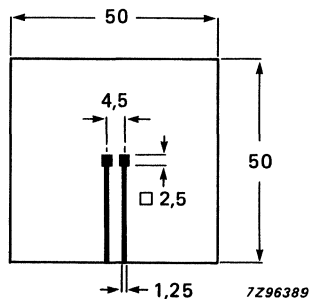

Fig. 2 Mounted on a printed-circuit board.

CHARACTERISTICS

$T_j = 25\text{ }^\circ\text{C}$ unless otherwise specified

		BYD17D	G	J	K	M
Forward voltage*						
$I_F = 1\text{ A}; T_j = T_{j\text{ max}}$	V_F	< 0,93	0,93	0,93	0,93	0,93 V
$I_F = 1\text{ A}$	V_F	< 1,05	1,05	1,05	1,05	1,05 V
Reverse avalanche breakdown voltage						
$I_R = 0,1\text{ mA}$	$V_{(BR)R}$	> 225	450	650	900	1100 V
		< 1600	1600	1600	1600	1600 V
Reverse current						
$V_R = V_{RWM\text{ max}}$	I_R	<		1		μA
$V_R = V_{RWM\text{ max}}; T_j = 165\text{ }^\circ\text{C}$	I_R	<		100		μA
Diode capacitance						
$V_R = 0; f = 1\text{ MHz}$	C_d	typ.		21		pF

DEVELOPMENT DATA

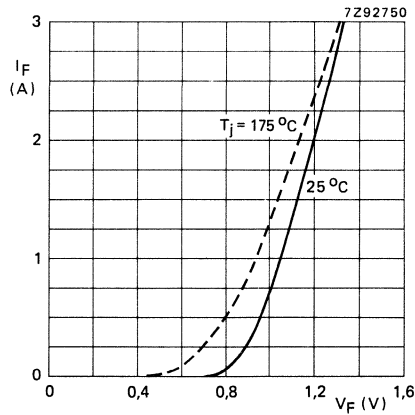

Fig. 3 Maximum forward voltage.

* Measured under pulse conditions to avoid excessive dissipation.

DEVELOPMENT DATA

This data sheet contains advance information and specifications are subject to change without notice.

BYD37D;G;J;K;M

AVALANCHE FAST SOFT-RECOVERY RECTIFIER DIODES

Rectifier diodes in hermetically sealed leadless SMID* envelopes. They are intended for television and industrial applications, such as switched-mode power supplies, scan rectifiers in TV receivers and also for use in inverter and converter applications. The devices feature non-snap-off (soft-recovery) switching characteristics and are capable of absorbing reverse transient energy (e.g. during flashover in a picture tube).

QUICK REFERENCE DATA

		BYD37D	G	J	K	M
Repetitive peak reverse voltage	V_{RRM}	max. 200	400	600	800	1000 V
Continuous reverse voltage	V_R	max. 200	400	600	600	1000 V
Average forward current	$I_F(AV)$	max.	1,5		1,5	A
Non-repetitive peak forward current	I_{FSM}	max.	20		20	A
Non-repetitive peak reverse energy	E_{RSM}	max.	10		7	mJ
Reverse recovery time	t_{rr}	<	250		300	ns

MECHANICAL DATA

Dimensions in mm

Fig. 1 SOD-87.

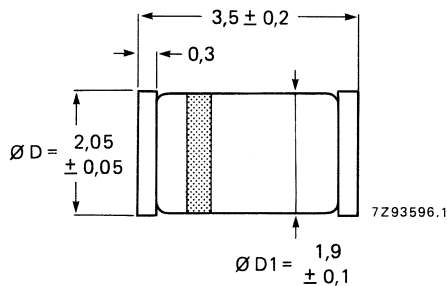

* Surface mounted implosion diode.

RATINGS

Limiting values in accordance with the Absolute Maximum System (IEC 134)

			BYD37D	G	J	K	M
Repetitive peak reverse voltage	V_{RRM}	max.	200	400	600	800	1000 V
Continuous reverse voltage	V_R	max.	200	400	600	800	1000 V
Average forward current (averaged over any 20 ms period)							
$T_{tp} = 105\text{ }^\circ\text{C}$	$I_{F(AV)}$	max.		1,5		1,5	A
$T_{amb} = 65\text{ }^\circ\text{C}$; p.c. board mounting	$I_{F(AV)}$	max.		0,6		0,6	A
Repetitive peak forward current	I_{FRM}	max.		12		12	A
Non-repetitive peak forward current							
$t = 10\text{ ms}$, half-sine wave; $T_j = T_{j\text{ max}}$ prior to surge; $V_R = V_{RRM\text{ max}}$	I_{FSM}	max.		20		20	A
Non-repetitive peak reverse avalanche energy; $I_R = 400\text{ mA}$; $T_j = T_{j\text{ max}}$, prior to surge; with inductive load switched off							
	E_{RSM}	max.		10		7	mJ
Storage temperature	T_{stg}				-65 to +175		$^\circ\text{C}$
Junction temperature	T_j	max.			175		$^\circ\text{C}$

THERMAL RESISTANCE

Influence of mounting method

1. Thermal resistance from junction to tie-point

$$R_{th\ j-tp} = 30\text{ K/W}$$

2. Thermal resistance from junction to ambient; device mounted on a 1,5 mm thick epoxy-glass printed circuit board; Cu-thickness $\geq 40\text{ }\mu\text{m}$ (see Fig. 2)

$$R_{th\ j-a} = 150\text{ K/W}$$

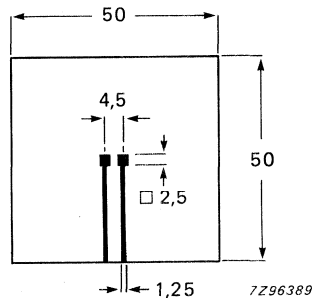

Fig. 2 Mounted on a printed-circuit board.

CHARACTERISTICS

$T_j = 25\text{ }^\circ\text{C}$ unless otherwise specified

		BYD37D	G	J	K	M	
Forward voltage*							
$I_F = 1\text{ A}; T_j = T_j \text{ max}$	$V_F <$	1,1	1,1	1,1	1,1	1,1	V
$I_F = 1\text{ A}$	$V_F <$	1,3	1,3	1,3	1,3	1,3	V
Reverse avalanche breakdown voltage							
$I_R = 0,1\text{ mA}$	$V_{(BR)R} >$	300	500	700	900	1100	V
Reverse current							
$V_R = V_{RRMmax}$	$I_R <$		1			1	μA
$V_R = V_{RRMmax}; T_j = 165\text{ }^\circ\text{C}$	$I_R <$		100			100	μA
Reverse recovery when switched from $I_F = 1\text{ A}$ to $V_R \geq 30\text{ V}$ with $-dI_F/dt = 20\text{ A}/\mu\text{s}$							
recovery charge	$Q_s <$		250			400	nC
recovery time	$t_{rr} <$		250			300	ns
Maximum slope of reverse recovery current when switched from $I_F = 1\text{ A}$ to $V_R \geq 30\text{ V}$ with $-dI_F/dt = 1\text{ A}/\mu\text{s}$							
	$ dI_R/dt <$		6			5	$\text{A}/\mu\text{s}$

DEVELOPMENT DATA

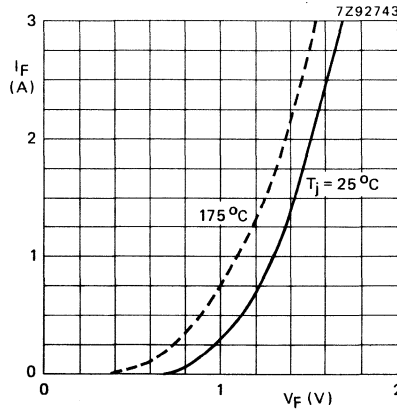

Fig. 3 Maximum forward voltage.

* Measured under pulse conditions to avoid excessive dissipation.

DEVELOPMENT DATA

This data sheet contains advance information and specifications are subject to change without notice.

BZD27 SERIES

VOLTAGE REGULATOR DIODES

Diodes in hermetically sealed leadless SMID* envelopes.

They are intended for use as voltage regulator in medium power regulator circuits.

The series consists of BZD27-C3V9 to BZD27-C270; diodes in the voltage range 300 V to 510 V are available on request.

QUICK REFERENCE DATA

Working voltage range	V_Z	nom.	3,9 to 270 V
Working voltage tolerance (E24 range)			$\pm 5 \%$
Total power dissipation	P_{tot}	max.	2,3 W
Non-repetitive peak reverse power dissipation $T_j = 25 \text{ }^\circ\text{C}; t_p = 100 \text{ } \mu\text{s}$	P_{ZSM}	max.	300 W

MECHANICAL DATA

Dimensions in mm

Fig. 1 SOD-87.

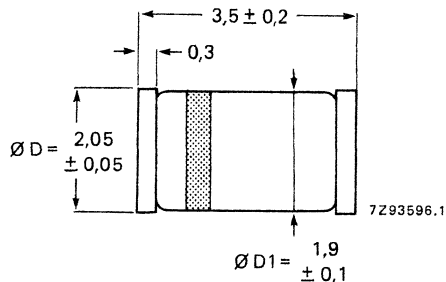

* Surface mounted implosion diode.

RATINGS

Limiting values in accordance with the Absolute Maximum System (IEC 134)

Total power dissipation

$$T_{tp} = 105 \text{ }^{\circ}\text{C}$$

$$T_{amb} = 55 \text{ }^{\circ}\text{C}; \text{ p.c. board mounting}$$

$$P_{tot} \quad \text{max.} \quad 2,3 \text{ W}$$

$$P_{tot} \quad \text{max.} \quad 0,8 \text{ W}$$

Non-repetitive peak reverse power dissipation

$$t_p = 100 \text{ } \mu\text{s square pulse}; T_j = 25 \text{ }^{\circ}\text{C (prior to surge)}$$

$$P_{ZSM} \quad \text{max.} \quad 300 \text{ W}$$

Storage temperature

$$T_{stg} \quad -65 \text{ to } +175 \text{ }^{\circ}\text{C}$$

Junction temperature

$$T_j \quad \text{max.} \quad 175 \text{ }^{\circ}\text{C}$$

THERMAL RESISTANCE

Influence of mounting method

1. Thermal resistance from junction to tie-point

$$R_{th \text{ j-tp}} = 30 \text{ K/W}$$

2. Thermal resistance from junction to ambient when mounted on a 1,5 mm thick epoxy-glass printed-circuit board; Cu-thickness $\geq 40 \text{ } \mu\text{m}$ (see Fig. 2)

$$R_{th \text{ j-a}} = 150 \text{ K/W}$$

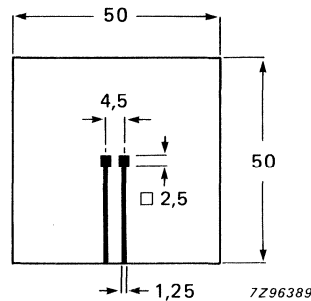

Fig. 2 Mounted on a printed-circuit board.

CHARACTERISTICS

$T_j = 25 \text{ }^{\circ}\text{C}$ unless otherwise specified

Forward voltage

$$I_F = 0,2 \text{ A}$$

$$V_F < 1,2 \text{ V}$$

CHARACTERISTICS (continued)

BZD27- XXXX	working voltage			differential resistance		temperature coefficient S_Z		test current I_Z mA	reverse at reverse current voltage	
	V_Z			r_{diff}		%/K			I_R μA	V_R V
	min.	typ.	max.	typ.	max.	min.	max.	max.		
C3V9	3,7	3,9	4,1	4	8	-0,14	-0,04	100	—	—
C4V3	4,0	4,3	4,6	4	7	-0,12	-0,02	100	—	—
C4V7	4,4	4,7	5,0	3	7	-0,10	0	100	—	—
C5V1	4,8	5,1	5,4	3	6	-0,08	0,02	100	100	2
C5V6	5,2	5,6	6,0	2	4	-0,04	0,04	100	50	2
C6V2	5,8	6,2	6,6	2	3	-0,01	0,06	100	20	2
C6V8	6,4	6,8	7,2	1	3	0	0,07	100	200	3
C7V5	7,0	7,5	7,9	1	2	0	0,07	100	50	3
C8V2	7,7	8,2	8,7	1	2	0,03	0,08	100	10	3
C9V1	8,5	9,1	9,6	2	4	0,03	0,08	50	5	5
C10	9,4	10,0	10,6	2	4	0,05	0,09	50	7	7,5
C11	10,4	11,0	11,6	4	7	0,05	0,10	50	3	8,2
C12	11,4	12,0	12,7	4	7	0,05	0,10	50	2	9,1
C13	12,4	13,0	14,1	5	10	0,05	0,10	50	2	10
C15	13,8	15,0	15,6	5	10	0,05	0,10	50	1	11
C16	15,3	16,0	17,1	6	15	0,06	0,11	25	1	12
C18	16,8	18,0	19,1	6	15	0,06	0,11	25	1	13
C20	18,8	20,0	21,2	6	15	0,06	0,11	25	1	15
C22	20,8	22,0	23,3	6	15	0,06	0,11	25	1	16
C24	22,8	24,0	25,6	7	15	0,06	0,11	25	1	18
C27	25,1	27,0	28,9	7	15	0,06	0,11	25	1	20
C30	28	30	32	8	15	0,06	0,11	25	1	22
C33	31	33	35	8	15	0,06	0,11	25	1	24
C36	34	36	38	21	40	0,06	0,11	10	1	27
C39	37	39	41	21	40	0,06	0,11	10	1	30
C43	40	43	46	24	45	0,07	0,12	10	1	33
C47	44	47	50	24	45	0,07	0,12	10	1	36
C51	48	51	54	25	60	0,07	0,12	10	1	39
C56	52	56	60	25	60	0,07	0,12	10	1	43
C62	58	62	66	25	80	0,08	0,13	10	1	47
C68	64	68	72	25	80	0,08	0,13	10	1	51
C75	70	75	79	30	100	0,08	0,13	10	1	56
C82	77	82	87	30	100	0,08	0,13	10	1	62
C91	85	91	96	60	200	0,09	0,13	5	1	68
C100	94	100	106	60	200	0,09	0,13	5	1	75
C110	104	110	116	80	250	0,09	0,13	5	1	82
C120	114	120	127	80	250	0,09	0,13	5	1	91
C130	124	130	141	110	300	0,09	0,13	5	1	100
C150	138	150	156	130	300	0,09	0,13	5	1	110
C160	153	160	171	150	350	0,09	0,13	5	1	120
C180	168	180	191	180	400	0,09	0,13	5	1	130
C200	188	200	212	200	500	0,09	0,13	5	1	150
C220	208	220	233	350	750	0,09	0,13	2	1	160
C240	228	240	256	400	850	0,09	0,13	2	1	180
C270	251	270	289	450	1000	0,09	0,13	2	1	200

DEVELOPMENT DATA

Diodes in the voltage range 300 V to 510 V available on request.

SILICON PLANAR VOLTAGE REGULATOR DIODES

Silicon planar voltage regulator diodes, in a SOT-89 plastic envelope, intended for stabilization applications in thick and thin-film circuits.

The series covers the normalized range of nominal working voltages from 2,4 V to 75 V with a tolerance of $\pm 5\%$ (international standard E24 range).

QUICK REFERENCE DATA

Working voltage range	V_Z	nom.	2,4 to 75 V
Working voltage tolerance (E24 range)			$\pm 5\%$
Total power dissipation up to $T_{amb} = 25\text{ }^\circ\text{C}$	P_{tot}	max.	1 W
Junction temperature	T_j	max.	150 $^\circ\text{C}$

MECHANICAL DATA

Dimensions in mm

Fig. 1 SOT-89

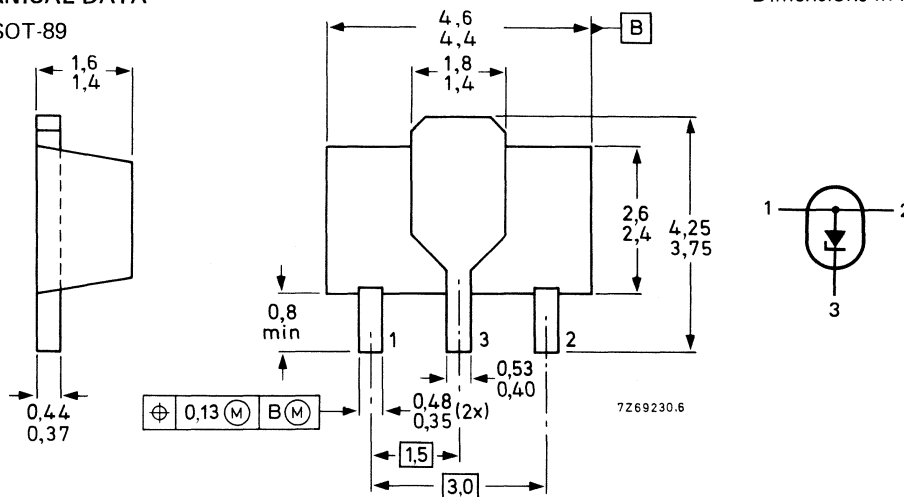

BOTTOM VIEW

Marking code

BZV49- C2V4 = 2Y4	C5V1 = 5Y1	C12 = 12Y	C33 = 33Y
C2V7 = 2Y7	C5V6 = 5Y6	C13 = 13Y	C36 = 36Y
C3V0 = 3Y0	C6V2 = 6Y2	C15 = 15Y	C39 = 39Y
C3V3 = 3Y3	C6V8 = 6Y8	C16 = 16Y	C43 = 43Y
C3V6 = 3Y6	C7V5 = 7Y5	C18 = 18Y	C47 = 47Y
C3V9 = 3Y9	C8V2 = 8Y2	C20 = 20Y	C51 = 51Y
C4V3 = 4Y3	C9V1 = 9Y1	C22 = 22Y	C56 = 56Y
C4V7 = 4Y7	C10 = 10Y	C24 = 24Y	C62 = 62Y
	C11 = 11Y	C27 = 27Y	C68 = 68Y
		C30 = 30Y	C75 = 75Y

RATINGS

Limiting values in accordance with the Absolute Maximum System (IEC 134)

Repetitive peak forward current	I_{FRM}	max.	250 mA
Average forward current (averaged over any 20 ms period)	$I_{F(AV)}$	max.	250 mA
Working current (d.c.)	I_Z	limited by P_{tot} max	
Total power dissipation * up to $T_{amb} = 25\text{ }^\circ\text{C}$	P_{tot}	max.	1 W
Non-repetitive peak reverse power dissipation * $T_j = 25\text{ }^\circ\text{C}$; $t_p = 100\text{ }\mu\text{s}$	P_{ZSM}	max.	40 W
Storage temperature	T_{stg}	-65 to +150 $^\circ\text{C}$	
Junction temperature	T_j	max.	150 $^\circ\text{C}$

THERMAL RESISTANCE

From junction to collector tab	$R_{th\ j-tab}$	=	15 K/W
From junction to ambient in free air *	$R_{th\ j-a}$	=	125 K/W

CHARACTERISTICS

$T_j = 25\text{ }^\circ\text{C}$

Forward voltage

$I_F = 50\text{ mA}$

$V_F < 1,0\text{ V}$

Reverse current

BZV49- C2V4	$V_R = 1\text{ V}$	$I_R < 50\text{ }\mu\text{A}$
C2V7	$V_R = 1\text{ V}$	$I_R < 20\text{ }\mu\text{A}$
C3V0	$V_R = 1\text{ V}$	$I_R < 10\text{ }\mu\text{A}$
C3V3	$V_R = 1\text{ V}$	$I_R < 5\text{ }\mu\text{A}$
C3V6	$V_R = 1\text{ V}$	$I_R < 5\text{ }\mu\text{A}$
C3V9	$V_R = 1\text{ V}$	$I_R < 3\text{ }\mu\text{A}$
C4V3	$V_R = 1\text{ V}$	$I_R < 3\text{ }\mu\text{A}$
C4V7	$V_R = 2\text{ V}$	$I_R < 3\text{ }\mu\text{A}$
C5V1	$V_R = 2\text{ V}$	$I_R < 2\text{ }\mu\text{A}$
C5V6	$V_R = 2\text{ V}$	$I_R < 1\text{ }\mu\text{A}$
C6V2	$V_R = 4\text{ V}$	$I_R < 3\text{ }\mu\text{A}$
C6V8	$V_R = 4\text{ V}$	$I_R < 2\text{ }\mu\text{A}$
C7V5	$V_R = 5\text{ V}$	$I_R < 1\text{ }\mu\text{A}$
C8V2	$V_R = 5\text{ V}$	$I_R < 700\text{ nA}$
C9V1	$V_R = 6\text{ V}$	$I_R < 500\text{ nA}$
C10	$V_R = 7\text{ V}$	$I_R < 200\text{ nA}$
C11 to C13	$V_R = 8\text{ V}$	$I_R < 100\text{ nA}$
C15 to C75	$V_R = 0,7\text{ V}_{Znom}$	$I_R < 50\text{ nA}$

* Device mounted on a ceramic substrate: area = 2,5 cm²; thickness = 0,7 mm.

$T_j = 25\text{ }^\circ\text{C}$ E24 logarithmic range (tolerance $\pm 5\%$)

BZV49-...	working voltage		differential resistance		temperature coefficient			diode capacitance	
	V_Z (V) at $I_{Z\text{test}} = 5\text{ mA}$		r_{diff} (Ω) at $I_{Z\text{test}} = 5\text{ mA}$		S_Z (mV/K) at $I_{Z\text{test}} = 5\text{ mA}$			C_d (pF); $f = 1\text{ MHz}$ $V_R = 0$	
	min.	max.	typ.	max.	min.	typ.	max.	typ.	max.
C2V4	2,2	2,6	70	100	-3,5	-1,6	0	375	450
C2V7	2,5	2,9	75	100	-3,5	-2,0	0	350	450
C3V0	2,8	3,2	80	95	-3,5	-2,1	0	350	450
C3V3	3,1	3,5	85	95	-3,5	-2,4	0	325	450
C3V6	3,4	3,8	85	90	-3,5	-2,4	0	300	450
C3V9	3,7	4,1	85	90	-3,5	-2,5	0	300	450
C4V3	4,0	4,6	80	90	-3,5	-2,5	0	275	450
C4V7	4,4	5,0	50	80	-3,5	-1,4	0,2	130	180
C5V1	4,8	5,4	40	60	-2,7	-0,8	1,2	110	160
C5V6	5,2	6,0	15	40	-2,0	1,2	2,5	95	140
C6V2	5,8	6,6	6	10	0,4	2,3	3,7	90	130
C6V8	6,4	7,2	6	15	1,2	3,0	4,5	85	110
C7V5	7,0	7,9	6	15	2,5	4,0	5,3	80	100
C8V2	7,7	8,7	6	15	3,2	4,6	6,2	75	95
C9V1	8,5	9,6	6	15	3,8	5,5	7,0	70	90
C10	9,4	10,6	8	20	4,5	6,4	8,0	70	90
C11	10,4	11,6	10	20	5,4	7,4	9,0	65	85
C12	11,4	12,7	10	25	6,0	8,4	10,0	65	85
C13	12,4	14,1	10	30	7,0	9,4	11,0	60	80
C15	13,8	15,6	10	30	9,2	11,4	13,0	55	75
C16	15,3	17,1	10	40	10,4	12,4	14,0	52	75
C18	16,8	19,1	10	45	12,4	14,4	16,0	47	70
C20	18,8	21,2	15	55	14,4	16,4	18,0	36	60
C22	20,8	23,3	20	55	16,4	18,4	20,0	34	60
C24	22,8	25,6	25	70	18,4	20,4	22,0	33	55
	at $I_{Z\text{test}} = 2\text{ mA}$		at $I_{Z\text{test}} = 2\text{ mA}$		at $I_{Z\text{test}} = 2\text{ mA}$				
C27	25,1	28,9	25	80	21,4	23,4	25,3	30	50
C30	28,0	32,0	30	80	24,4	26,6	29,4	27	50
C33	31,0	35,0	35	80	27,4	29,7	33,4	25	45
C36	34,0	38,0	35	90	30,4	33,0	37,4	23	45
C39	37,0	41,0	40	130	33,4	36,4	41,2	21	45
C43	40,0	46,0	45	150	37,6	41,2	46,6	21	40
C47	44,0	50,0	50	170	42,0	46,1	51,8	19	40
C51	48,0	54,0	60	180	46,6	51,0	57,2	19	40
C56	52,0	60,0	70	200	52,2	57,0	63,8	18	40
C62	58,0	66,0	80	215	58,8	64,4	71,6	17	35
C68	64,0	72,0	90	240	65,6	71,7	79,8	17	35
C75	70,0	79,0	95	255	73,4	80,2	88,6	16,5	35

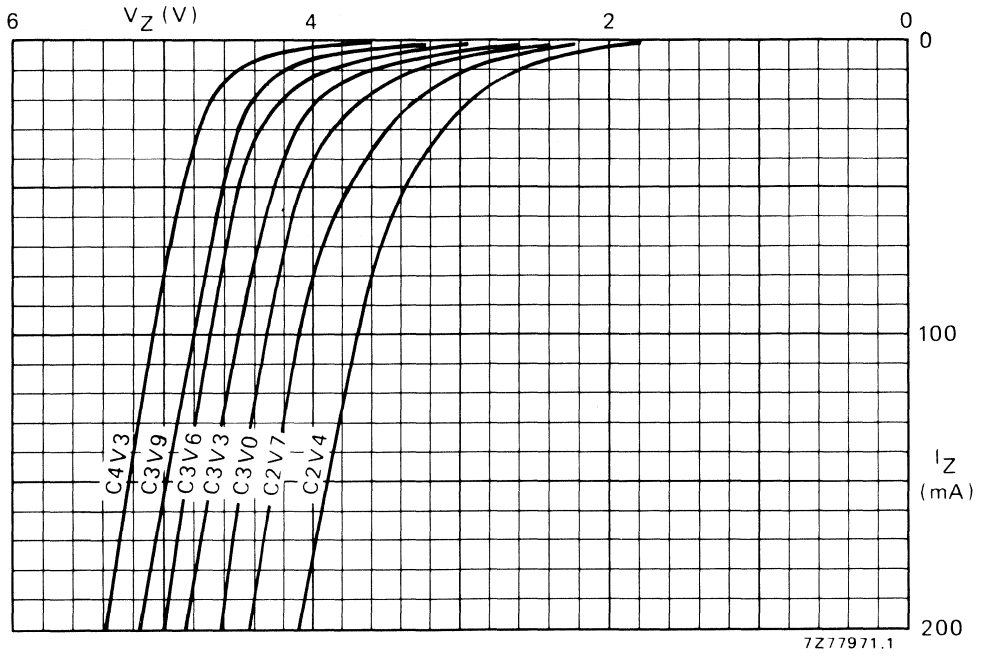

Fig. 2 Dynamic characteristics; typical values; $T_j = 25^\circ\text{C}$.

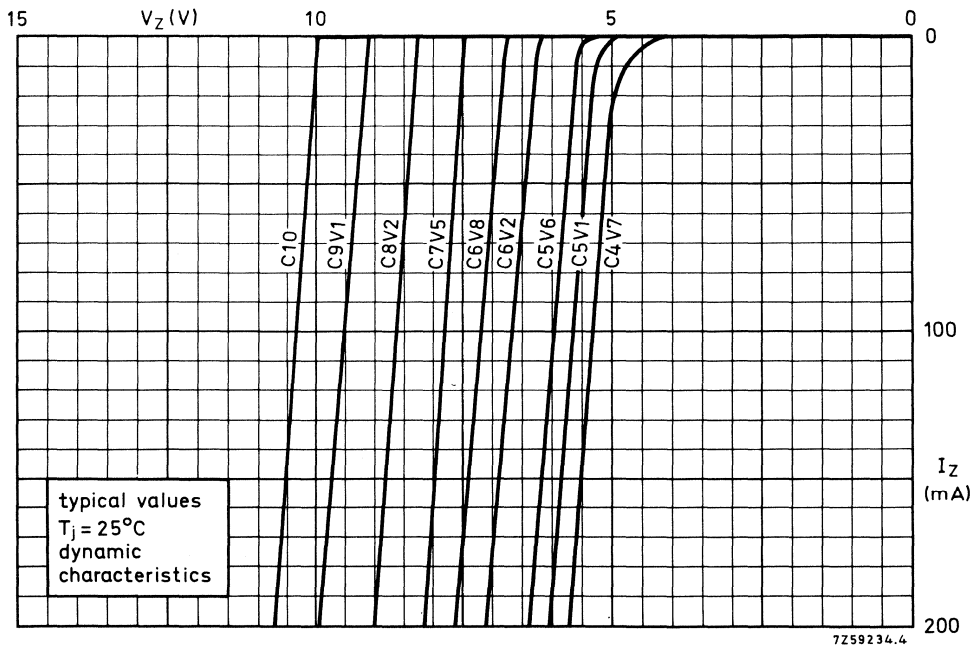

Fig. 3 Dynamic characteristics; typical values at $T_j = 25^\circ\text{C}$.

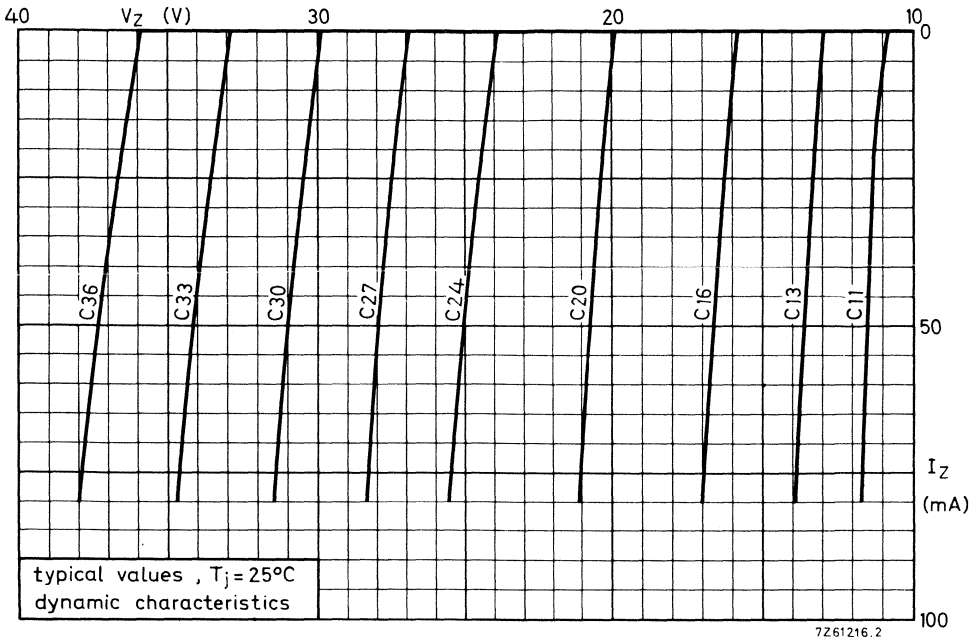

Fig. 4 Dynamic characteristics; typical values; $T_j = 25^\circ\text{C}$.

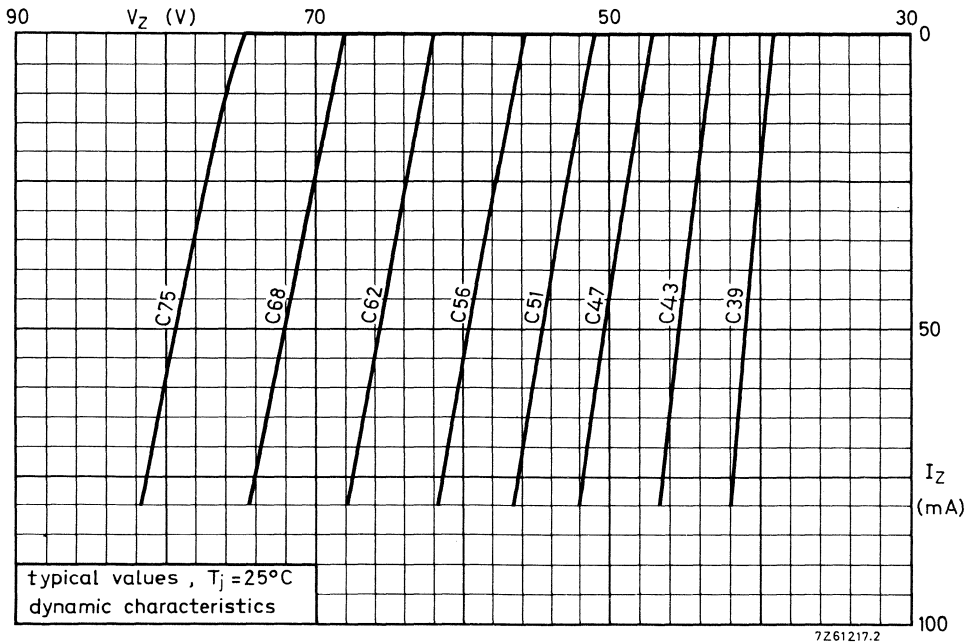

Fig. 5 Dynamic characteristics; typical values at $T_j = 25^\circ\text{C}$.

Model for calculating the static working voltage ($V_{Z\ stat}$).

This model can be derived from $V_{Z\ stat} = V_{Z\ dyn} + \Delta V_Z$ of which $V_{Z\ dyn}$ is given in the preceding tables and can be derived from the typical dynamic characteristic curves (Figs 2, 3, 4 and 5)

$\Delta V_Z = \Delta T \times S_Z$. For S_Z see tables and graphs S_Z versus T_j .

$\Delta T = P_{tot} \times R_{th\ j-a} = I_Z \times V_{Z\ dyn} \times R_{th\ j-a}$.

Following $\Delta V_Z = I_Z \times V_{Z\ dyn} \times R_{th\ j-a} \times S_Z$ and the model will be:

$$V_{Z\ stat} = V_{Z\ dyn} + I_Z \times V_{Z\ dyn} \times R_{th\ j-a} \times S_Z$$

Calculating example

BZV49-C24 mounted on a ceramic substrate of 7 x 5 x 0,5 mm; at $I_Z = 7\ mA$.

$$V_{Z\ stat} = 24 + \left(\frac{7}{1000} \times 24 \times \frac{125}{1000} \times 20,3 \right)$$

$$= 24 + 0,4 = 24,4\ V.$$

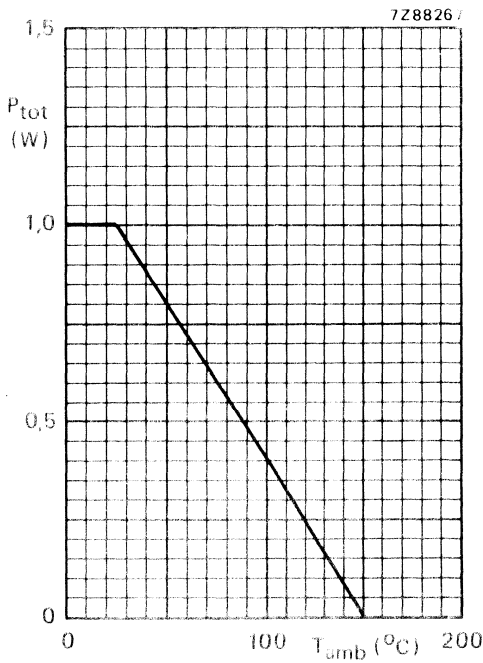

Fig. 6 Power derating curve.

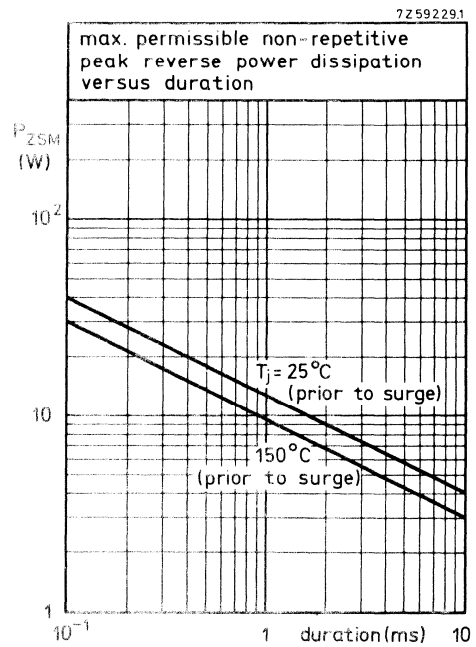

Fig. 7.

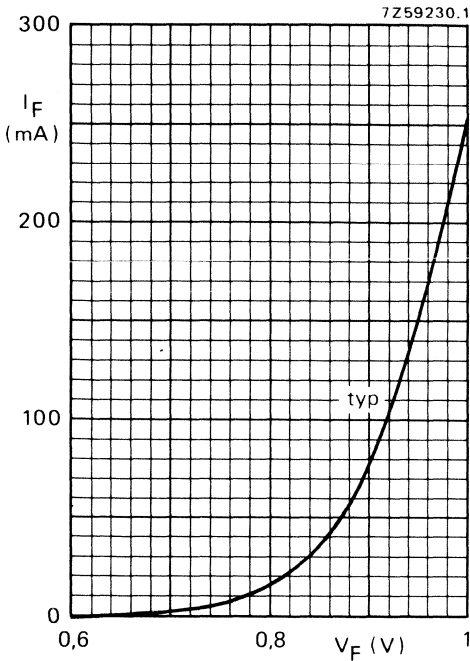

Fig. 8 $T_j = 25\text{ }^\circ\text{C}$.

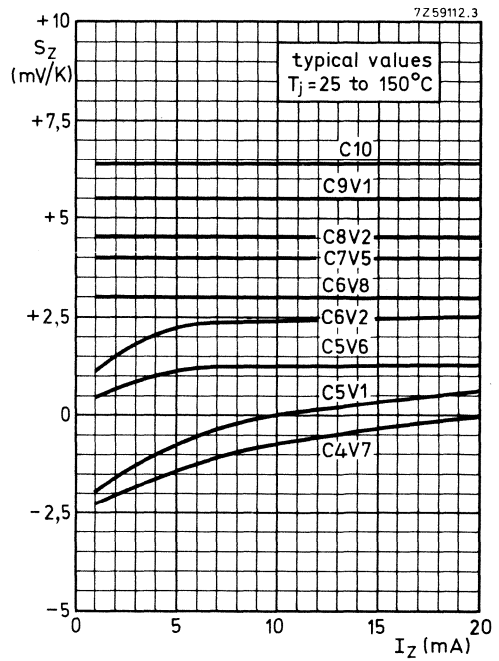

Fig. 9.

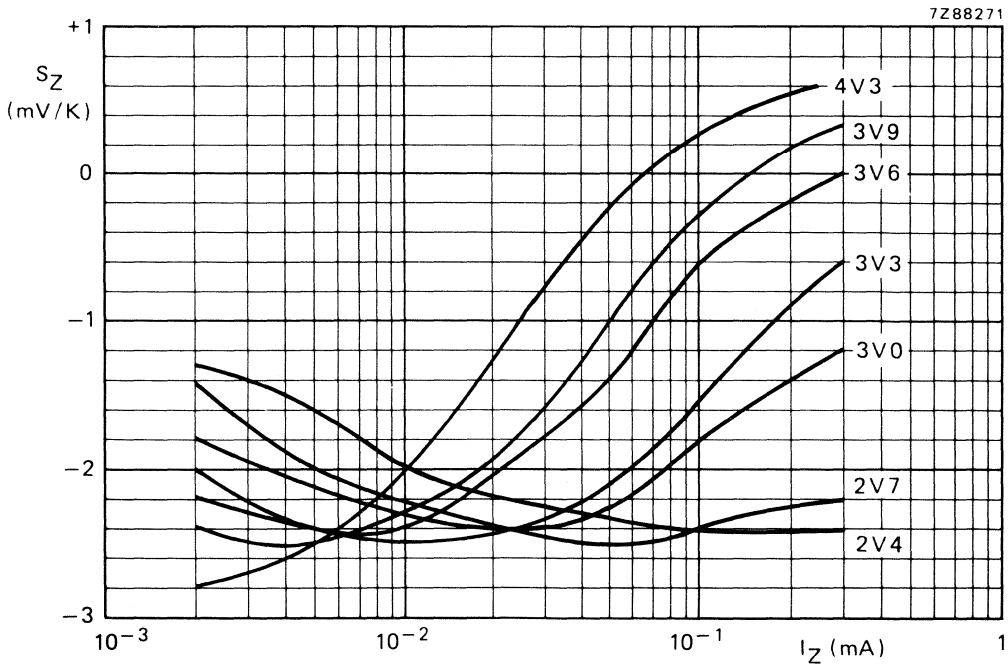

Fig. 10 Typical values temperature coefficient.

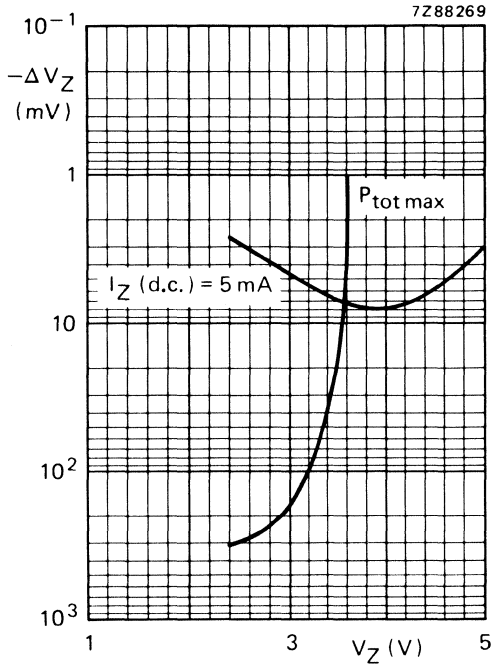

Fig. 11 Typical change of working voltage;
 $T_j = 25\ ^\circ C.$

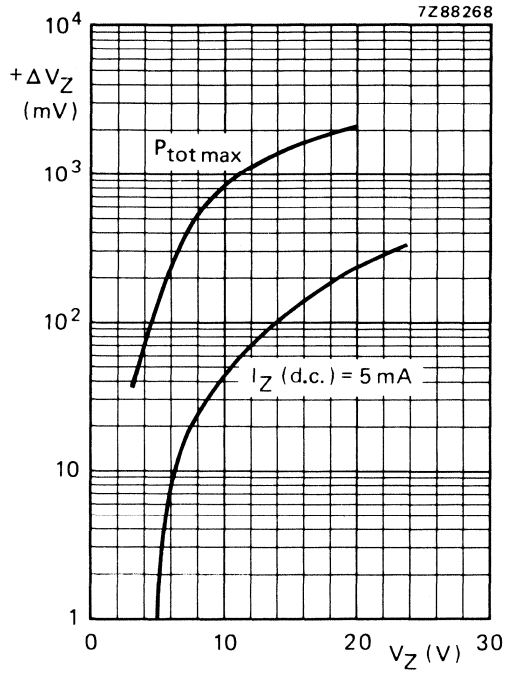

Fig. 12 Typical change of working voltage;
 $T_{amb} = 25\ ^\circ C.$

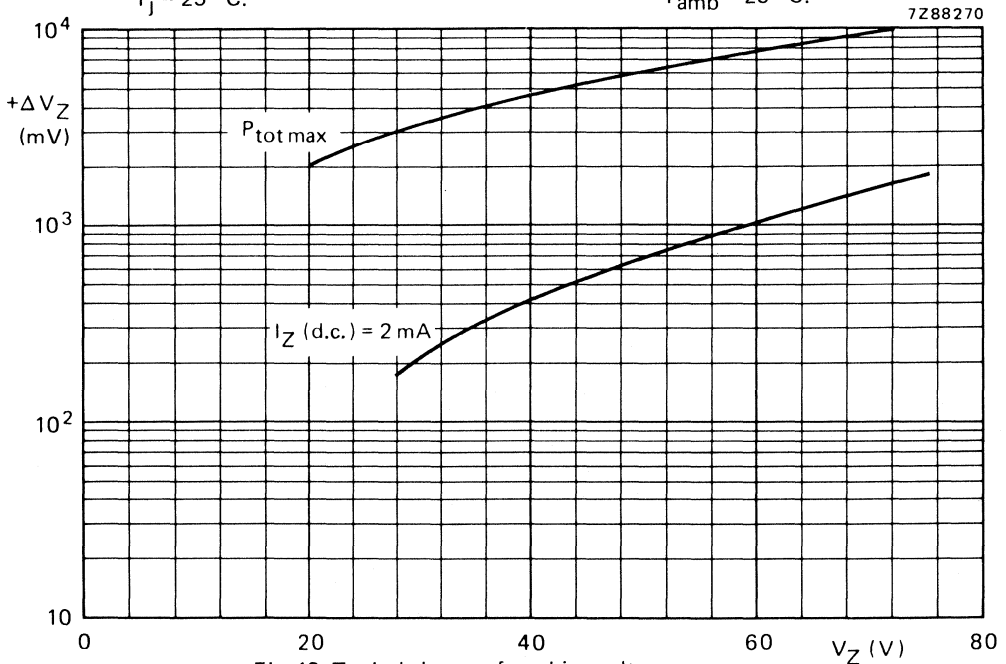

Fig. 13 Typical change of working voltage.

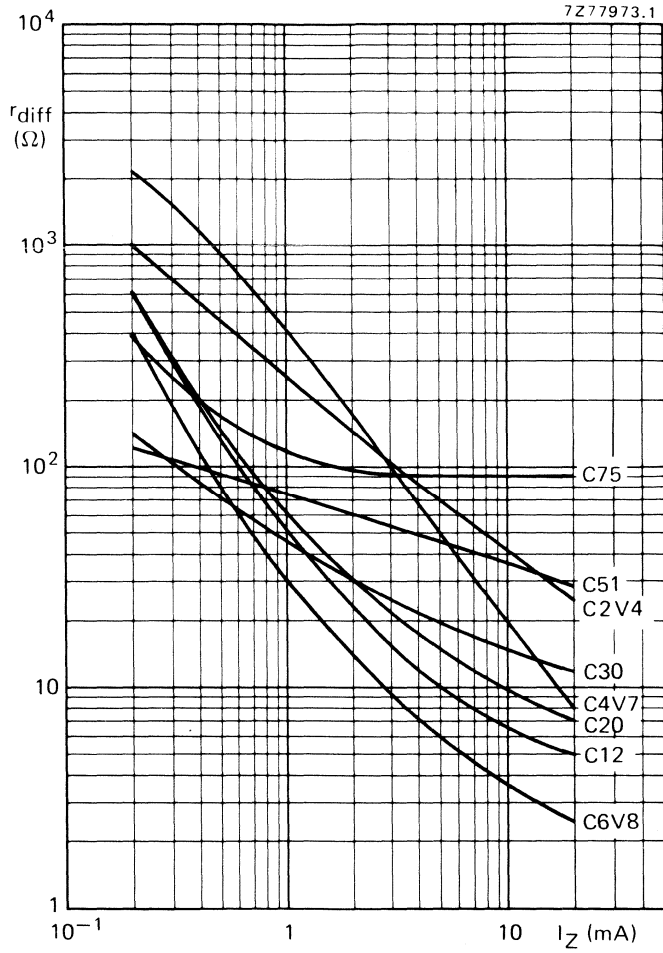

Fig. 14 Typical values; $T_j = 25^\circ\text{C}$; $f = 1\text{ kHz}$.

DEVELOPMENT DATA

This data sheet contains advance information and specifications are subject to change without notice.

BZV55 SERIES

VOLTAGE REGULATOR DIODES FOR SURFACE MOUNTING

Silicon planar diodes designed for use as low-voltage stabilizers or voltage references. They are available in the international standardized E24 ($\pm 5\%$) range. The series consists of 37 types with nominal working voltages ranging from 2,4 V to 75 V.

The SM diode is a leadless diode in an hermetically sealed glass SOD-80 envelope with tinplated metal discs at each end. It is suitable for "automatic placement" and as such it can withstand immersion soldering.

The diodes are delivered in "super 8" tape.

QUICK REFERENCE DATA

Working voltage range	V_Z	nom. 2,4 to 75 V
Total power dissipation up to flange temperature of 50 °C	P_{tot}	max. 500 mW
Non-repetitive peak reverse power dissipation	P_{ZSM}	max. 30 W
Junction temperature	T_j	max. 200 °C
Thermal resistance from junction to tie-point	$R_{th j-tp}$	= 0,30 K/mW

MECHANICAL DATA

Dimensions in mm

Fig. 1 SOD-80.

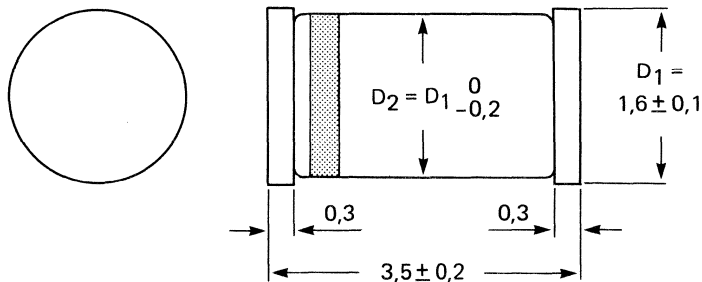

7Z91084.1

The BZV55 cathode is indicated by a yellow band.

RATINGS

Limiting values in accordance with the Absolute Maximum System (IEC 134).

Average forward current (averaged over any 20 ms period)	$I_{F(AV)}$	max.	250 mA
Repetitive peak forward current	I_{FRM}	max.	250 mA
Total power dissipation up to $T_{flange} = 50\text{ }^{\circ}\text{C}$	P_{tot}	max.	500 mW
up to $T_{amb} = 50\text{ }^{\circ}\text{C}$ and mounted on a ceramic substrate of 10 mm x 10 mm x 0,6 mm	P_{tot}	max.	400 mW
Non-repetitive peak reverse power dissipation $t = 100\text{ }\mu\text{s}; T_j = 150\text{ }^{\circ}\text{C}$	P_{ZSM}	max.	30 W
Storage temperature	T_{stg}	-65 to +200	$^{\circ}\text{C}$
Junction temperature	T_j	max.	200 $^{\circ}\text{C}$

THERMAL RESISTANCE

From junction to tie-point (flanges)	$R_{th\ j-tp}$	=	0,30 K/mW
From junction to ambient when mounted on a ceramic substrate of 10 mm x 10 mm x 0,6 mm	$R_{th\ j-a}$	=	0,38 K/mW

CHARACTERISTICS

$T_j = 25\text{ }^{\circ}\text{C}$ unless otherwise specified

Forward voltage $I_F = 10\text{ mA}$	V_F	<	0,9 V
Reverse current	I_R	<	
BZV55-.2V4 $V_R = 1\text{ V}$	I_R	<	50 μA
.2V7 $V_R = 1\text{ V}$	I_R	<	20 μA
.3V0 $V_R = 1\text{ V}$	I_R	<	10 μA
.3V3 $V_R = 1\text{ V}$	I_R	<	5 μA
.3V6 $V_R = 1\text{ V}$	I_R	<	5 μA
.3V9 $V_R = 1\text{ V}$	I_R	<	3 μA
.4V3 $V_R = 1\text{ V}$	I_R	<	3 μA
.4V7 $V_R = 2\text{ V}$	I_R	<	3 μA
.5V1 $V_R = 2\text{ V}$	I_R	<	2 μA
.5V6 $V_R = 2\text{ V}$	I_R	<	1 μA
.6V2 $V_R = 4\text{ V}$	I_R	<	3 μA
.6V8 $V_R = 4\text{ V}$	I_R	<	2 μA
.7V5 $V_R = 5\text{ V}$	I_R	<	1 μA
.8V2 $V_R = 5\text{ V}$	I_R	<	700 nA
.9V1 $V_R = 6\text{ V}$	I_R	<	500 nA
.10 $V_R = 7\text{ V}$	I_R	<	200 nA
.11 to .13 $V_R = 8\text{ V}$	I_R	<	100 nA
.15 to .75 $V_R = 0,7 V_{Znom}$	I_R	<	50 nA
. = C for E24 ($\pm 5\%$) tolerance			

$T_j = 25\text{ }^\circ\text{C}$ E24 ($\pm 5\%$) logarithmic range

BZV55- ...	working voltage		differential resistance		temperature coefficient			diode capacitance	
	V_Z (V)		r_{diff} (Ω)		S_Z (mV/K)			C_d (pF)	
	at $I_{Ztest} = 5\text{ mA}$		at $I_{Ztest} = 5\text{ mA}$		at $I_{Ztest} = 5\text{ mA}$			at $f = 1\text{ MHz}$	
	min.	max.	typ.	max.	min.	typ.	max.	typ.	max.
C2V4	2,2	2,6	70	100	-3,5	-1,6	0	375	450
C2V7	2,5	2,9	75	100	-3,5	-2,0	0	350	450
C3V0	2,8	3,2	80	95	-3,5	-2,1	0	350	450
C3V3	3,1	3,5	85	95	-3,5	-2,4	0	325	450
C3V6	3,4	3,8	85	90	-3,5	-2,4	0	300	450
C3V9	3,7	4,1	85	90	-3,5	-2,5	0	300	450
C4V3	4,0	4,6	80	90	-3,5	-2,5	0	275	450
C4V7	4,4	5,0	50	80	-3,5	-1,4	0,2	125	180
C5V1	4,8	5,4	40	60	-2,7	-0,8	1,2	125	180
C5V6	5,2	6,0	15	40	-2,0	1,2	2,5	125	180
C6V2	5,8	6,6	6	10	0,4	2,3	3,7	90	130
C6V8	6,4	7,2	6	15	1,2	3,0	4,5	85	110
C7V5	7,0	7,9	6	15	2,5	4,0	5,3	80	100
C8V2	7,7	8,7	6	15	3,2	4,6	6,2	75	95
C9V1	8,5	9,6	6	15	3,8	5,5	7,0	70	90
C10	9,4	10,6	8	20	4,5	6,4	8,0	70	90
C11	10,4	11,6	10	20	5,4	7,4	9,0	65	85
C12	11,4	12,7	10	25	6,0	8,4	10,0	65	85
C13	12,4	14,1	10	30	7,0	9,4	11,0	60	80
C15	13,8	15,6	10	30	9,2	11,4	13,0	55	75
C16	15,3	17,1	10	40	10,4	12,4	14,0	52	75
C18	16,8	19,1	10	45	12,4	14,4	16,0	47	70
C20	18,8	21,2	15	55	14,4	16,4	18,0	36	60
C22	20,8	23,3	20	55	16,4	18,4	20,0	34	60
C24	22,8	25,6	25	70	18,4	20,4	22,0	33	55
	at $I_{Ztest} = 2\text{ mA}$		at $I_{Ztest} = 2\text{ mA}$		at $I_{Ztest} = 2\text{ mA}$				
C27	25,1	28,9	25	80	21,4	23,4	25,3	30	50
C30	28,0	32,0	30	80	24,4	26,6	29,4	27	50
C33	31,0	35,0	35	80	27,4	29,7	33,4	25	45
C36	34,0	38,0	35	90	30,4	33,0	37,4	23	45
C39	37,0	41,0	40	130	33,4	36,4	41,2	21	45
C43	40,0	46,0	45	150	37,6	41,2	46,6	21	40
C47	44,0	50,0	50	170	42,0	46,1	51,8	19	40
C51	48,0	54,0	60	180	46,6	51,0	57,2	19	40
C56	52,0	60,0	70	200	52,2	57,0	63,8	18	40
C62	58,0	66,0	80	215	58,8	64,4	71,6	17	35
C68	64,0	72,0	90	240	65,6	71,7	79,8	17	35
C75	70,0	79,0	95	255	73,4	80,2	88,6	16,5	35

BZV55 SERIES

$T_j = 25\text{ }^\circ\text{C}$

E24 ($\pm 5\%$) logarithmic range

BZV55- ...	working voltage			differential resistance		working voltage			differential resistance	
	V_Z (V) at $I_Z = 1\text{ mA}$			r_{diff} (Ω) at $I_Z = 1\text{ mA}$		V_Z (V) at $I_Z = 20\text{ mA}$			r_{diff} (Ω) at $I_Z = 20\text{ mA}$	
	min.	nom.	max.	typ.	max.	min.	nom.	max.	typ.	max.
C2V4	1,7	1,9	2,1	275	600	2,6	2,9	3,2	25	50
C2V7	1,9	2,2	2,4	300	600	3,0	3,3	3,6	25	50
C3V0	2,1	2,4	2,7	325	600	3,3	3,6	3,9	25	50
C3V3	2,3	2,6	2,9	350	600	3,6	3,9	4,2	20	40
C3V6	2,7	3,0	3,3	375	600	3,9	4,2	4,5	20	40
C3V9	2,9	3,2	3,5	400	600	4,1	4,4	4,7	15	30
C4V3	3,3	3,6	4,0	410	600	4,4	4,7	5,1	15	30
C4V7	3,7	4,2	4,7	425	500	4,5	5,0	5,4	8	15
C5V1	4,2	4,7	5,3	400	480	5,0	5,4	5,9	6	15
C5V6	4,8	5,4	6,0	80	400	5,2	5,7	6,3	4	10
C6V2	5,6	6,1	6,6	40	150	5,8	6,3	6,8	3	6
C6V8	6,3	6,7	7,2	30	80	6,4	6,9	7,4	2,5	6
C7V5	6,9	7,4	7,9	30	80	7,0	7,6	8,0	2,5	6
C8V2	7,6	8,1	8,7	40	80	7,7	8,3	8,8	3	6
C9V1	8,4	9,0	9,6	40	100	8,5	9,2	9,7	4	8
C10	9,3	9,9	10,6	50	150	9,4	10,1	10,7	4	10
C11	10,2	10,9	11,6	50	150	10,4	11,1	11,8	5	10
C12	11,2	11,9	12,7	50	150	11,4	12,1	12,9	5	10
C13	12,3	12,9	14,0	50	170	12,5	13,1	14,2	5	15
C15	13,7	14,9	15,5	50	200	13,9	15,1	15,7	6	20
C16	15,2	15,9	17,0	50	200	15,4	16,1	17,2	6	20
C18	16,7	17,9	19,0	50	225	16,9	18,1	19,2	6	20
C20	18,7	19,9	21,1	60	225	18,9	20,1	21,4	7	20
C22	20,7	21,9	23,2	60	250	20,9	22,1	23,4	7	25
C24	22,7	23,9	25,5	60	250	22,9	24,1	25,7	7	25
	at $I_Z = 0,1\text{ mA}$			at $I_Z = 0,5\text{ mA}$		at $I_Z = 10\text{ mA}$			at $I_Z = 10\text{ mA}$	
C27	25,0	26,9	28,9	65	300	25,2	27,1	29,3	10	45
C30	27,8	29,9	32,0	70	300	28,1	30,1	32,4	15	50
C33	30,8	32,9	35,0	75	325	31,1	33,1	35,4	20	55
C36	33,8	35,9	38,0	80	350	34,1	36,1	38,4	25	60
C39	36,7	38,9	41,0	80	350	37,1	39,1	41,5	25	70
C43	39,7	42,9	46,0	85	375	40,1	43,1	46,5	25	80
C47	43,7	46,8	50,0	85	375	44,1	47,1	50,5	30	90
C51	47,6	50,8	54,0	90	400	48,1	51,1	54,6	35	100
C56	51,5	55,7	60,0	100	425	52,1	56,1	60,8	45	110
C62	57,4	61,7	66,0	120	450	58,2	62,1	67,0	60	120
C68	63,4	67,7	72,0	150	475	64,2	68,2	73,2	75	130
C75	69,4	74,7	79,0	170	500	70,3	75,3	80,2	90	140

DEVELOPMENT DATA

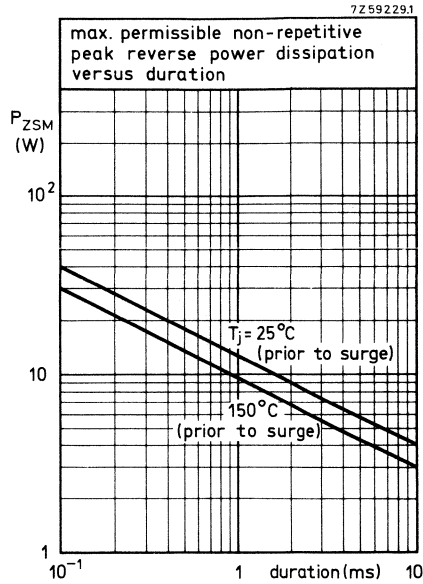

Fig. 2.

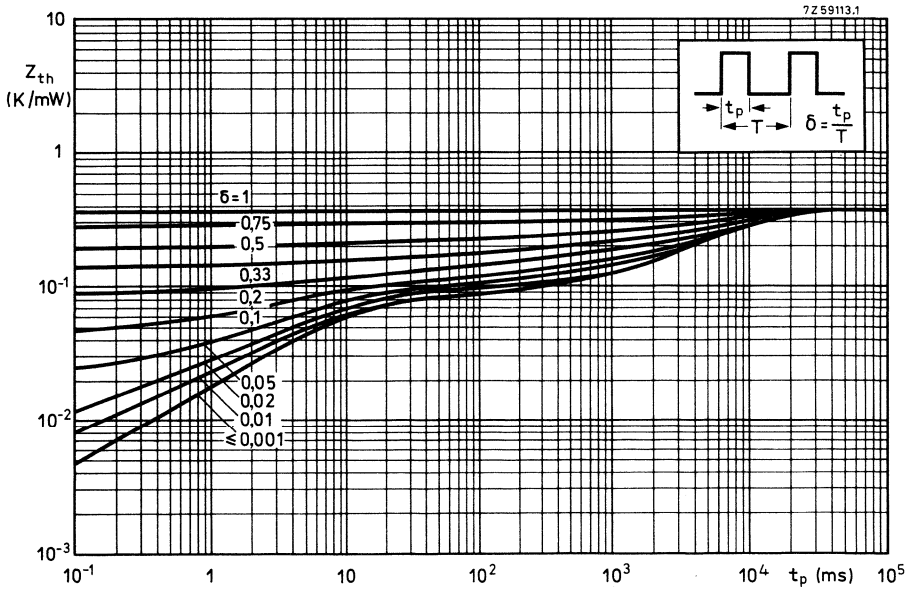

Fig. 3.

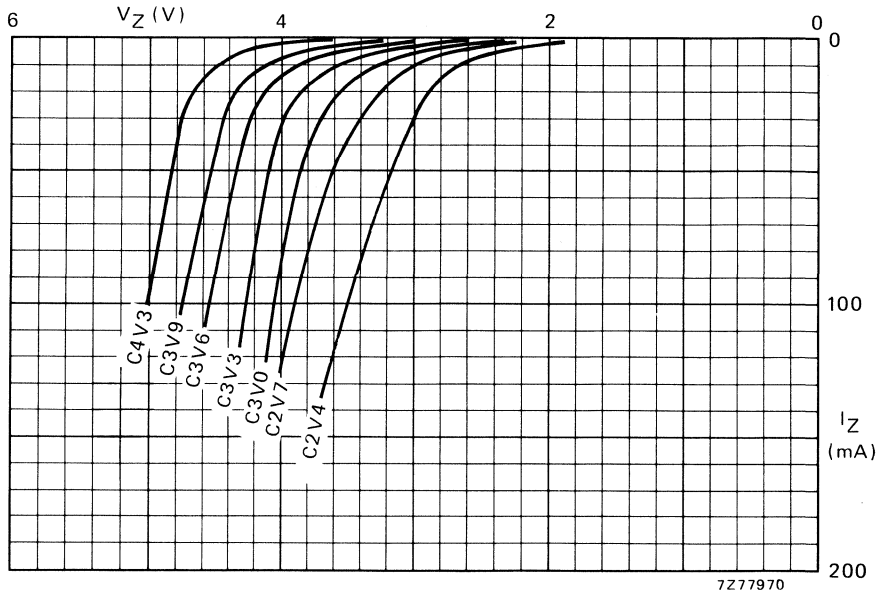

Fig. 4 Static characteristics; typical values; $T_{amb} = 25^\circ\text{C}$.

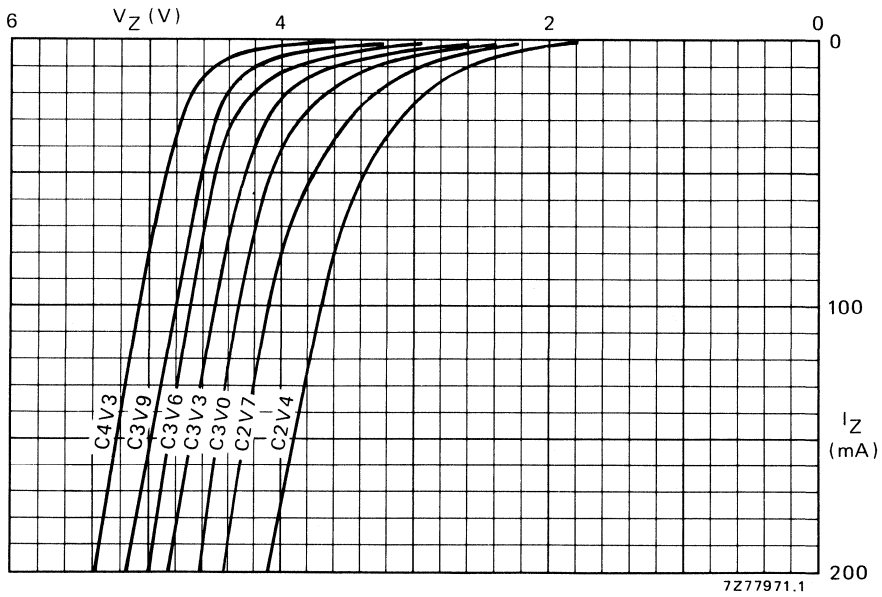

Fig. 5 Dynamic characteristics; typical values; $T_j = 25^\circ\text{C}$.

DEVELOPMENT DATA

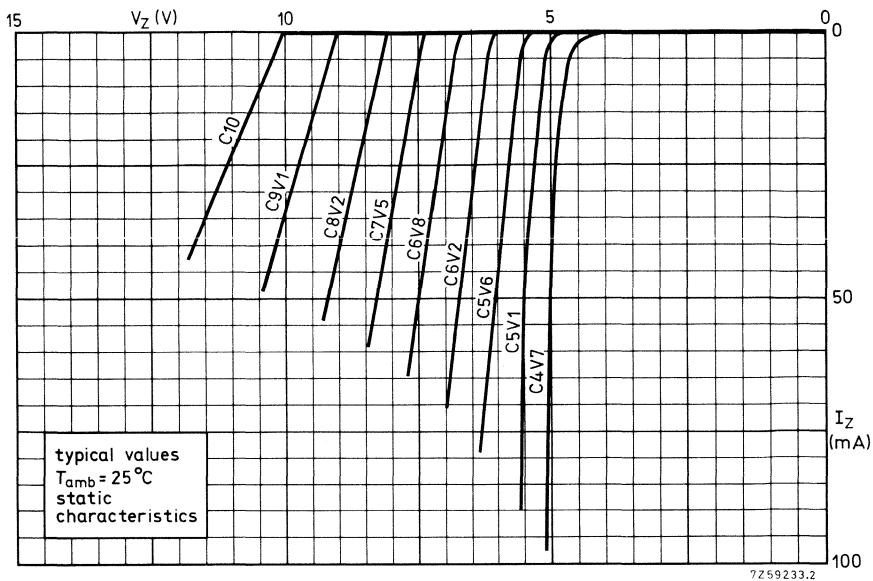

Fig. 6.

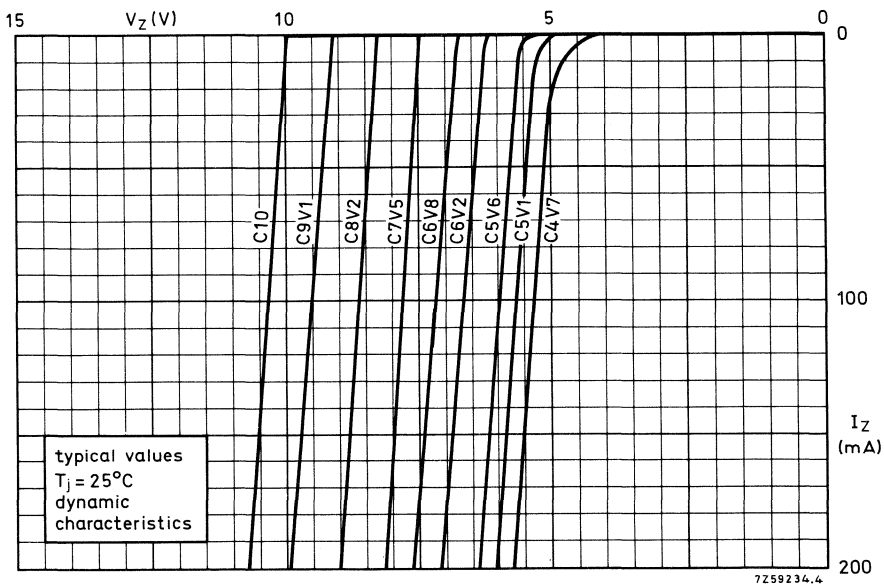

Fig. 7.

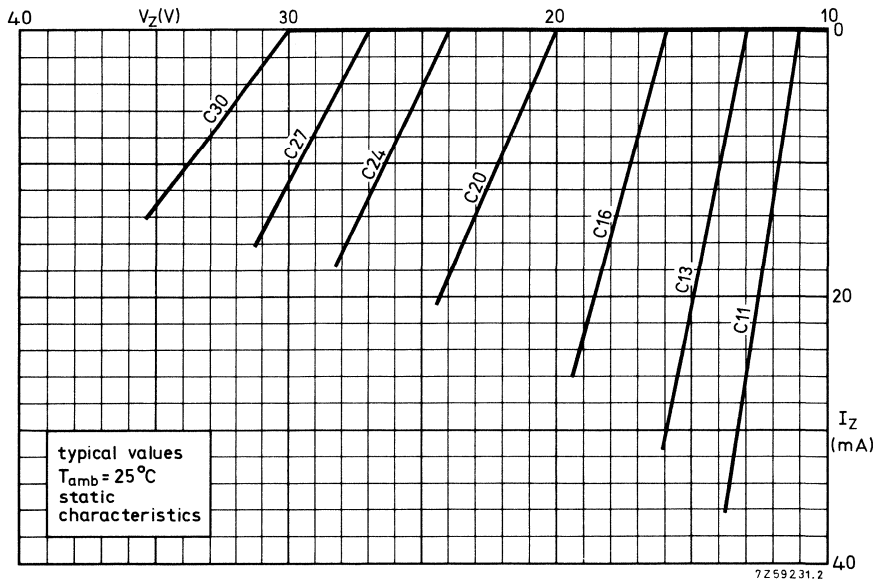

Fig. 8.

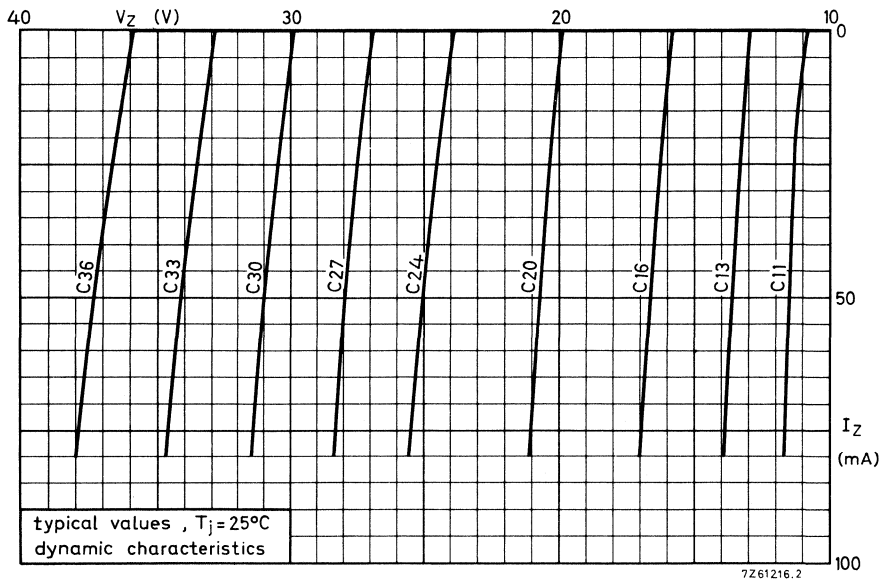

Fig. 9.

DEVELOPMENT DATA

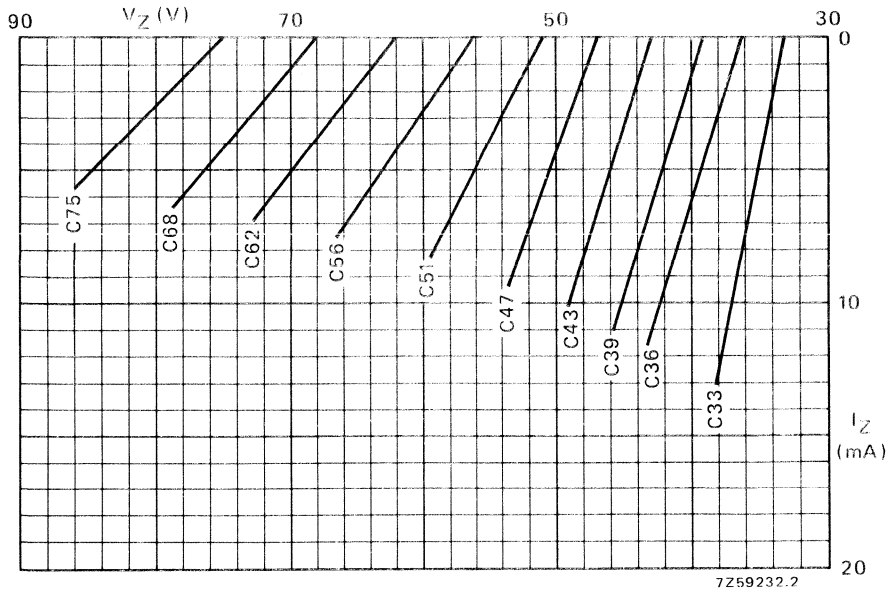

Fig. 10 Static characteristics; typical values; $T_{amb} = 25^{\circ}C$.

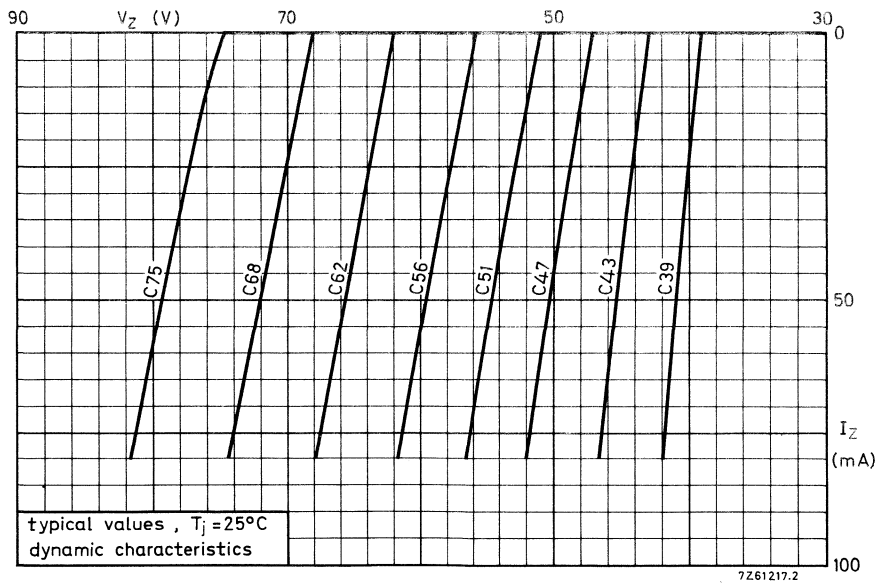

Fig. 11.

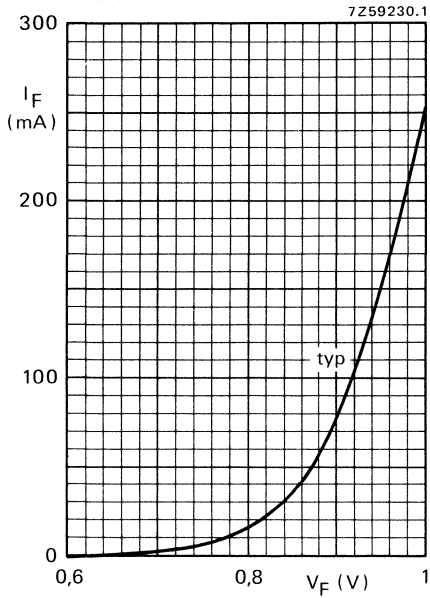

Fig. 12 $T_j = 25\text{ }^\circ\text{C}$.

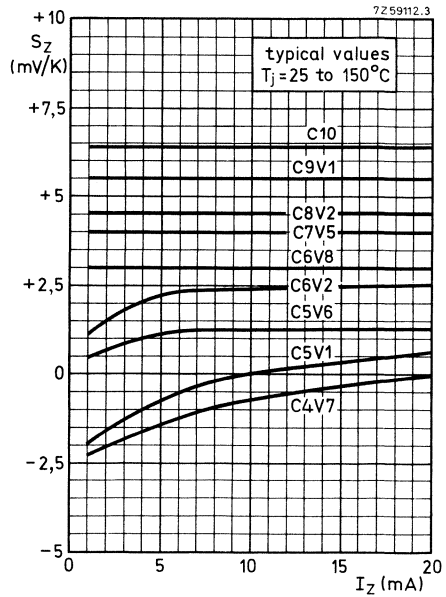

Fig. 13.

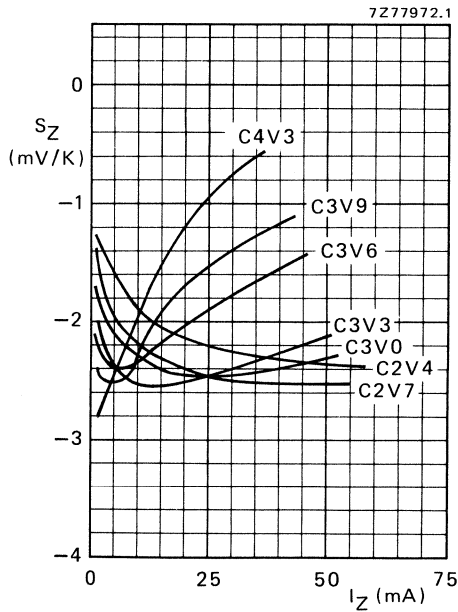

Fig. 14 Typical values; $T_j = 25\text{ to }150\text{ }^\circ\text{C}$.

DEVELOPMENT DATA

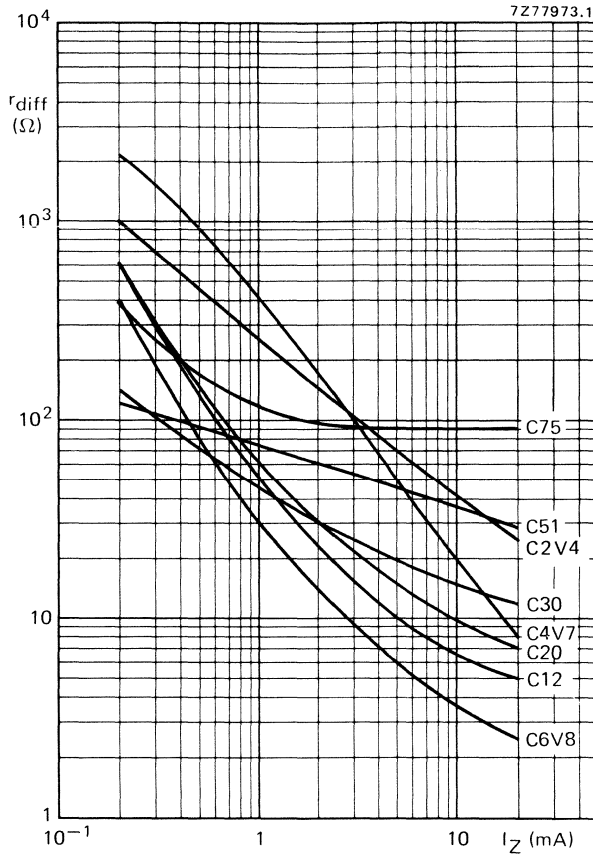

Fig. 15 Typical values; $T_j = 25\text{ }^\circ\text{C}$; $f = 1\text{ kHz}$.

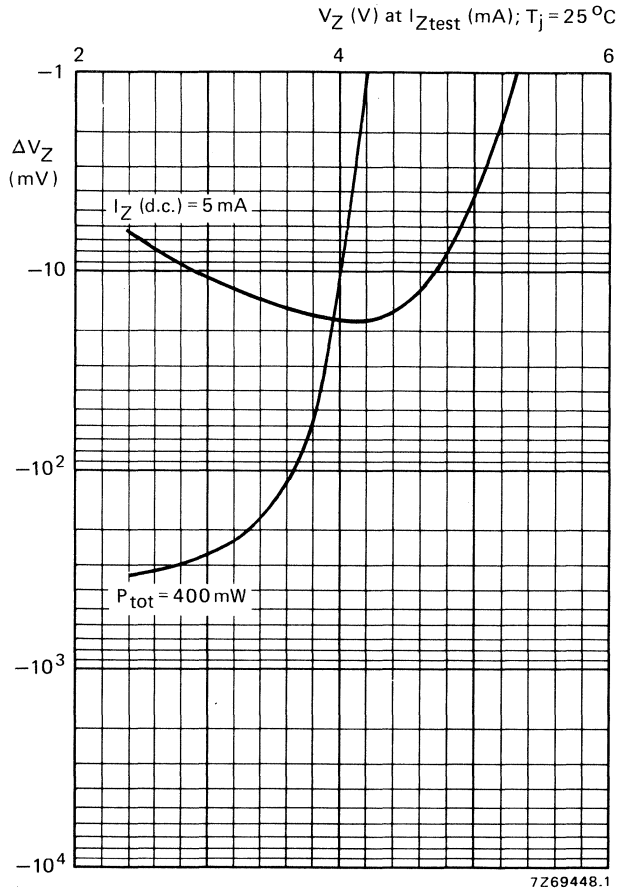

Fig. 16 Typical change of working voltage under operating conditions at $T_{amb} = 25^\circ\text{C}$.

DEVELOPMENT DATA

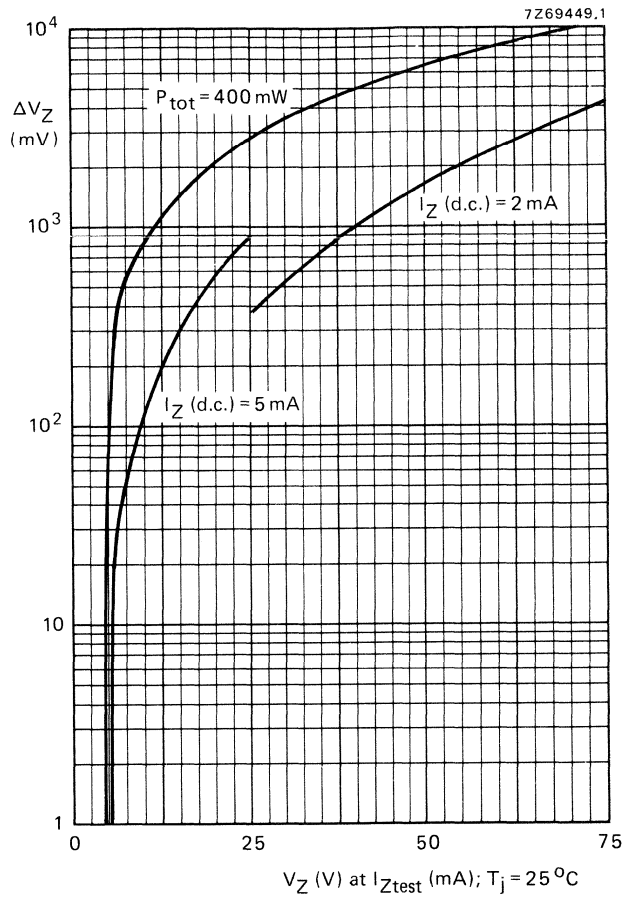

Fig. 17 Typical change of working voltage under operating conditions at $T_{amb} = 25 \text{ }^\circ\text{C}$.

SILICON PLANAR VOLTAGE REGULATOR DIODES

Low power general purpose voltage regulator diodes in a microminiature plastic envelope intended for application in thick and thin-film circuits. The series covers the normalized range of nominal working voltages from 2,4 V to 75 V with a working voltage tolerance of $\pm 5\%$.

QUICK REFERENCE DATA

Working voltage range	V_Z	nom.	2,4 to 75 V
Working voltage tolerance			$\pm 5\%$
Total power dissipation up to $T_{amb} = 25\text{ }^\circ\text{C}$	P_{tot}	max.	350 mW
Junction temperature	T_j	max.	175 $^\circ\text{C}$

MECHANICAL DATA

Fig. 1 SOT-23.

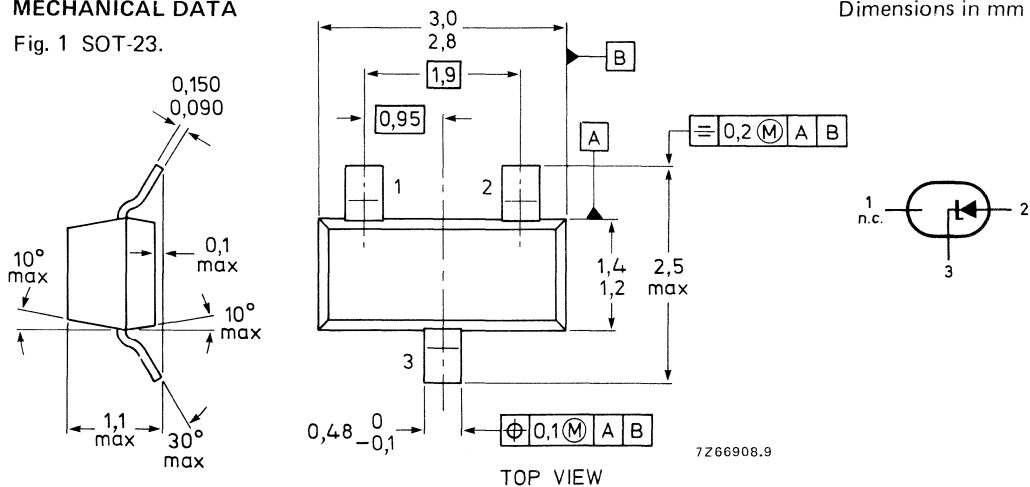

See also *Soldering recommendations*.

Marking code

BZX84-C2V4 = Z11	BZX84-C5V6 = Z3	BZX84-C13 = Y3	BZX84-C33 = Y12
C2V7 = Z12	C6V2 = Z4	C15 = Y4	C36 = Y13
C3V0 = Z13	C6V8 = Z5	C16 = Y5	C39 = Y14
C3V3 = Z14	C7V5 = Z6	C18 = Y6	C43 = Y15
C3V6 = Z15	C8V2 = Z7	C20 = Y7	C47 = Y16
C3V9 = Z16	C9V1 = Z8	C22 = Y8	C51 = Y17
C4V3 = Z17	C10 = Z9	C24 = Y9	C56 = Y18
C4V7 = Z1	C11 = Y1	C27 = Y10	C62 = Y19
C5V1 = Z2	C12 = Y2	C30 = Y11	C68 = Y20
			C75 = Y21

RATINGS

Limiting values in accordance with the Absolute Maximum System (IEC 134)

Repetitive peak forward current	I_{FRM}	max.	250 mA
Repetitive peak working current	I_{ZRM}	max.	250 mA
Total power dissipation up to $T_{amb} = 25\text{ }^{\circ}\text{C}^{**}$	P_{tot}	max.	350 mW
Storage temperature	T_{stg}	-65 to +	175 $^{\circ}\text{C}$
Junction temperature	T_j	max.	175 $^{\circ}\text{C}$

THERMAL CHARACTERISTICS*

$$T_j = P \times (R_{th\ j-t} + R_{th\ t-s} + R_{th\ s-a}) + T_{amb}$$

Thermal resistance

From junction to tab	$R_{th\ j-t}$	=	50 K/W
From tab to soldering points	$R_{th\ t-s}$	=	280 K/W
From soldering points to ambient**	$R_{th\ s-a}$	=	90 K/W

CHARACTERISTICS

$T_j = 25\text{ }^{\circ}\text{C}$ unless otherwise specified

Forward voltage

$$I_F = 10\text{ mA}$$

$$V_F < 0,9\text{ V}$$

Reverse current

BZX84-C2V4

$$V_R = 1\text{ V}$$

$$I_R < 50\text{ }\mu\text{A}$$

C2V7

$$V_R = 1\text{ V}$$

$$I_R < 20\text{ }\mu\text{A}$$

C3V0

$$V_R = 1\text{ V}$$

$$I_R < 10\text{ }\mu\text{A}$$

C3V3

$$V_R = 1\text{ V}$$

$$I_R < 5\text{ }\mu\text{A}$$

C3V6

$$V_R = 1\text{ V}$$

$$I_R < 5\text{ }\mu\text{A}$$

C3V9

$$V_R = 1\text{ V}$$

$$I_R < 3\text{ }\mu\text{A}$$

C4V3

$$V_R = 1\text{ V}$$

$$I_R < 3\text{ }\mu\text{A}$$

C4V7

$$V_R = 2\text{ V}$$

$$I_R < 3\text{ }\mu\text{A}$$

C5V1

$$V_R = 2\text{ V}$$

$$I_R < 2\text{ }\mu\text{A}$$

C5V6

$$V_R = 2\text{ V}$$

$$I_R < 1\text{ }\mu\text{A}$$

C6V2

$$V_R = 4\text{ V}$$

$$I_R < 3\text{ }\mu\text{A}$$

C6V8

$$V_R = 4\text{ V}$$

$$I_R < 2\text{ }\mu\text{A}$$

C7V5

$$V_R = 5\text{ V}$$

$$I_R < 1\text{ }\mu\text{A}$$

C8V2

$$V_R = 5\text{ V}$$

$$I_R < 700\text{ nA}$$

C9V1

$$V_R = 6\text{ V}$$

$$I_R < 500\text{ nA}$$

C10

$$V_R = 7\text{ V}$$

$$I_R < 200\text{ nA}$$

C11

$$V_R = 8\text{ V}$$

$$I_R < 100\text{ nA}$$

C12

$$V_R = 8\text{ V}$$

$$I_R < 100\text{ nA}$$

C13

$$V_R = 8\text{ V}$$

$$I_R < 100\text{ nA}$$

C15 to C75

$$V_R = 0,7\text{ }V_{Znom}$$

$$I_R < 50\text{ nA}$$

* See *Thermal characteristics*.

** Device mounted on a ceramic substrate of 8 mm x 10 mm x 0,7 mm.

BZX84-....	working voltage		differential resistance		temperature coefficient			diode capacitance	
	V_Z (V)		r_{diff} (Ω)		S_Z (mV/K)			C_D (pF): $f = 1$ MHz; $V_R = 0$ ←	
	at $I_{Ztest} = 5$ mA		at $I_{Ztest} = 5$ mA		at $I_{Ztest} = 5$ mA				
	min.	max.	typ.	max.	min.	typ.	max.	typ.	max.
C2V4	2,2	2,6	70	100	-3,5	-1,6	0	375	450
C2V7	2,5	2,9	75	100	-3,5	-2,0	0	350	450
C3V0	2,8	3,2	80	95	-3,5	-2,1	0	350	450
C3V3	3,1	3,5	85	95	-3,5	-2,4	0	325	450
C3V6	3,4	3,8	85	90	-3,5	-2,4	0	300	450
C3V9	3,7	4,1	85	90	-3,5	-2,5	0	300	450 ←
C4V3	4,0	4,6	80	90	-3,5	-2,5	0	275	450
C4V7	4,4	5,0	50	80	-3,5	-1,4	0,2	245	300
C5V1	4,8	5,4	40	60	-2,7	-0,8	1,2	235	300
C5V6	5,2	6,0	15	40	-2,0	1,2	2,5	225	300
C6V2	5,8	6,6	6	10	0,4	2,3	3,7	125	200
C6V8	6,4	7,2	6	15	1,2	3,0	4,5	105	200
C7V5	7,0	7,9	6	15	2,5	4,0	5,3	95	150
C8V2	7,7	8,7	6	15	3,2	4,6	6,2	90	150
C9V1	8,5	9,6	6	15	3,8	5,5	7,0	70	150
C10	9,4	10,6	8	20	4,5	6,4	8,0	70	90
C11	10,4	11,6	10	20	5,4	7,4	9,0	65	85
C12	11,4	12,7	10	25	6,0	8,4	10,0	65	85
C13	12,4	14,1	10	30	7,0	9,4	11,0	60	80
C15	13,8	15,6	10	30	9,2	11,4	13,0	55	75
C16	15,3	17,1	10	40	10,4	12,4	14,0	52	75
C18	16,8	19,1	10	45	12,4	14,4	16,0	47	70
C20	18,8	21,2	15	55	14,4	16,4	18,0	36	60
C22	20,8	23,3	20	55	16,4	18,4	20,0	34	60
C24	22,8	25,6	25	70	18,4	20,4	22,0	33	55
	at $I_Z = 2$ mA		at $I_Z = 2$ mA		at $I_Z = 2$ mA				
	min.	max.	typ.	max.	min.	typ.	max.	typ.	max.
C27	25,1	28,9	25	80	21,4	23,4	25,3	30	50
C30	28,0	32,0	30	80	24,4	26,6	29,4	27	50
C33	31,0	35,0	35	80	27,4	29,7	33,4	25	45
C36	34,0	38,0	35	90	30,4	33,0	37,4	23	45
C39	37,0	41,0	40	130	33,4	36,4	41,2	21	45
C43	40,0	46,0	45	150	37,6	41,2	46,6	21	40
C47	44,0	50,0	50	170	42,0	46,1	51,8	19	40
C51	48,0	54,0	60	180	46,6	51,0	57,2	19	40
C56	52,0	60,0	70	200	52,2	57,0	63,8	18	40
C62	58,0	66,0	80	215	58,8	64,4	71,6	17	35
C68	64,0	72,0	90	240	65,6	71,7	79,8	17	35
C75	70,0	79,0	95	255	73,4	80,2	88,6	16,5	35

BZX84 SERIES

BZX84....	working voltage			differential resistance		working voltage			differential resistance	
	V_Z (V)			r_{diff} (Ω)		V_Z (V)			r_{diff} (Ω)	
	at $I_Z = 1$ mA			at $I_Z = 1$ mA		at $I_Z = 20$ mA			at $I_Z = 20$ mA	
	min.	nom.	max.	typ.	max.	min.	nom.	max.	typ.	max.
C2V4	1,7	1,9	2,1	275	600	2,6	2,9	3,2	25	50
C2V7	1,9	2,2	2,4	300	600	3,0	3,3	3,6	25	50
C3V0	2,1	2,4	2,7	325	600	3,3	3,6	3,9	25	50
C3V3	2,3	2,6	2,9	350	600	3,6	3,9	4,2	20	40
C3V6	2,7	3,0	3,3	375	600	3,9	4,2	4,5	20	40
C3V9	2,9	3,2	3,5	400	600	4,1	4,4	4,7	15	30
C4V3	3,3	3,6	4,0	410	600	4,4	4,7	5,1	15	30
C4V7	3,7	4,2	4,7	425	500	4,5	5,0	5,4	8	15
C5V1	4,2	4,7	5,3	400	480	5,0	5,4	5,9	6	15
C5V6	4,8	5,4	6,0	80	400	5,2	5,7	6,3	4	10
C6V2	5,6	6,1	6,6	40	150	5,8	6,3	6,8	3	6
C6V8	6,3	6,7	7,2	30	80	6,4	6,9	7,4	2,5	6
C7V5	6,9	7,4	7,9	30	80	7,0	7,6	8,0	2,5	6
C8V2	7,6	8,1	8,7	40	80	7,7	8,3	8,8	3	6
C9V1	8,4	9,0	9,6	40	100	8,5	9,2	9,7	4	8
C10	9,3	9,9	10,6	50	150	9,4	10,1	10,7	4	10
C11	10,2	10,9	11,6	50	150	10,4	11,1	11,8	5	10
C12	11,2	11,9	12,7	50	150	11,4	12,1	12,9	5	10
C13	12,3	12,9	14,0	50	170	12,5	13,1	14,2	5	15
C15	13,7	14,9	15,5	50	200	13,9	15,1	15,7	6	20
C16	15,2	15,9	17,0	50	200	15,4	16,1	17,2	6	20
C18	16,7	17,9	19,0	50	225	16,9	18,1	19,2	6	20
C20	18,7	19,9	21,1	60	225	18,9	20,1	21,4	7	20
C22	20,7	21,9	23,2	60	250	20,9	22,1	23,4	7	25
C24	22,7	23,9	25,5	60	250	22,9	24,1	25,7	7	25
	at $I_Z = 0,1$ mA			at $I_Z = 0,5$ mA		at $I_Z = 10$ mA			at $I_Z = 10$ mA	
	min.	nom.	max.	typ.	max.	min.	nom.	max.	typ.	max.
C27	25,0	26,9	28,9	65	300	25,2	27,1	29,3	10	45
C30	27,8	29,9	32,0	70	300	28,1	30,1	32,4	15	50
C33	30,8	32,9	35,0	75	325	31,1	33,1	35,4	20	55
C36	33,8	35,9	38,0	80	350	34,1	36,1	38,4	25	60
C39	36,7	38,9	41,0	80	350	37,1	39,1	41,5	25	70
C43	39,7	42,9	46,0	85	375	40,1	43,1	46,5	25	80
C47	43,7	46,8	50,0	85	375	44,1	47,1	50,5	30	90
C51	47,6	50,8	54,0	90	400	48,1	51,1	54,6	35	100
C56	51,5	55,7	60,0	100	425	52,1	56,1	60,8	45	110
C62	57,4	61,7	66,0	120	450	58,2	62,1	67,0	60	120
C68	63,4	67,7	72,0	150	475	64,2	68,2	73,2	75	130
C75	69,4	74,7	79,0	170	500	70,3	75,3	80,2	90	140

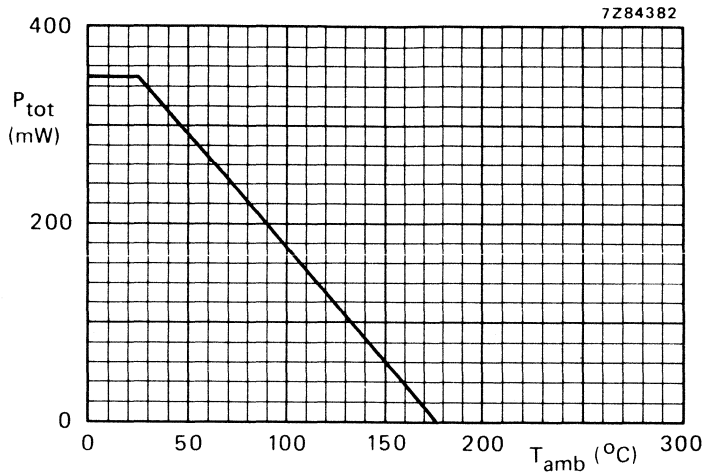

Fig. 2 Power derating curve.

Model for calculating the static working voltage (V_Z stat).

This model can be derived from V_Z stat = V_Z dyn + ΔV_Z of which V_Z dyn is given in the preceding tables and can be derived from the typical dynamic characteristic curves in Figs 3 to 6.

$\Delta V_Z = \Delta T \times S_Z$. For S_Z see tables and graphs S_Z versus T_j .

$\Delta T = P_{tot} \times R_{th\ j-a} = I_Z \times V_Z$ dyn $\times R_{th\ j-a}$.

Following $\Delta V_Z = I_Z \times V_Z$ dyn $\times R_{th\ j-a} \times S_Z$ and the model will be:

$$V_Z$$
 stat = V_Z dyn + $I_Z \times V_Z$ dyn $\times R_{th\ j-a} \times S_Z$

Calculating example

BZX84-C24 mounted on a ceramic substrate of 7 x 5 x 0,6 mm; at $I_Z = 7$ mA.

$$V_Z$$
 stat = 24 + $\left(\frac{7}{1000}\right) \times 24 \times \frac{430}{1000} \times 20,3$

$$= 24 + 1,47 = 25,47 \text{ V.}$$

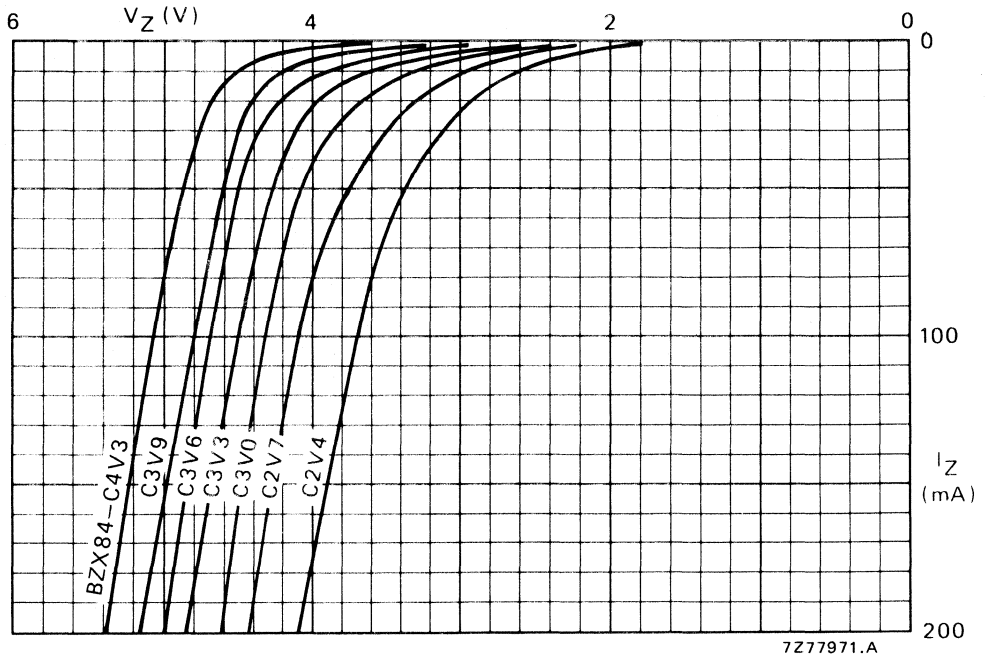

Fig. 3 Dynamic characteristics; typical values; $T_j = 25^\circ\text{C}$.

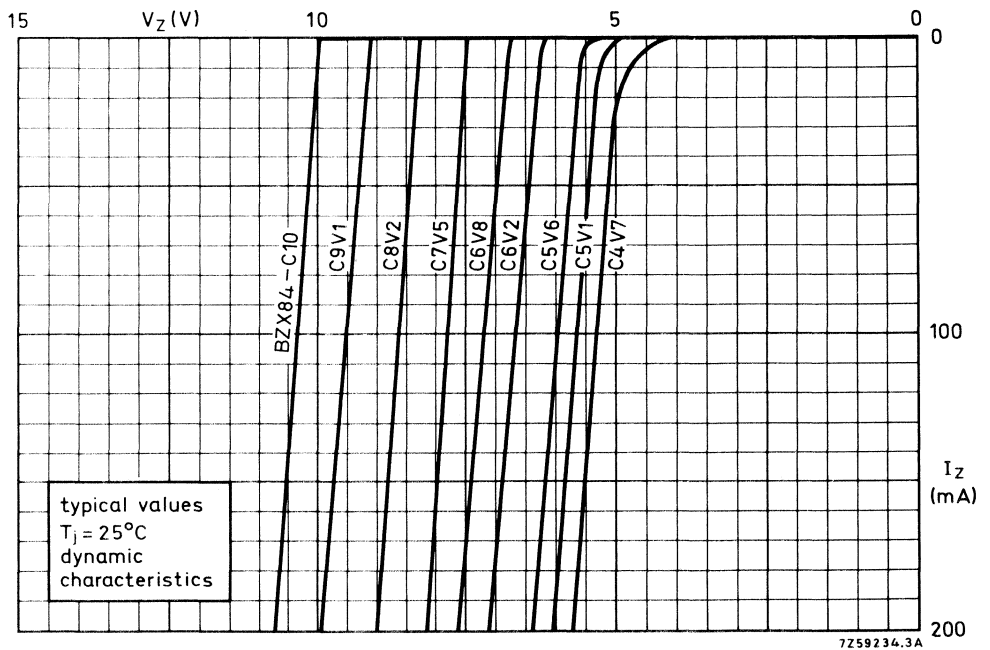

Fig. 4 Dynamic characteristics; typical values; $T_j = 25^\circ\text{C}$.

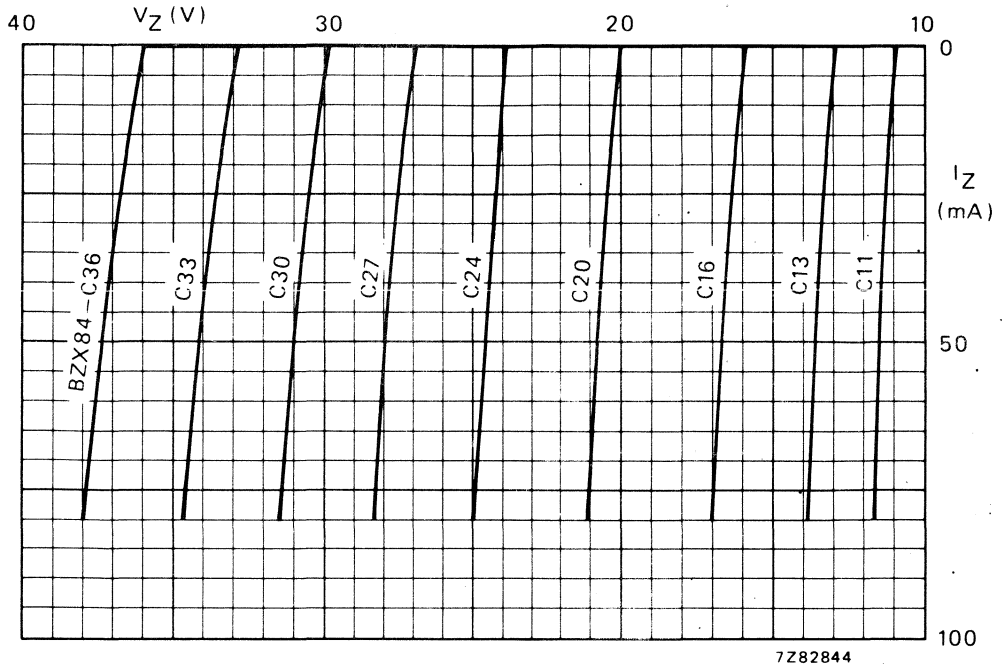

Fig. 5 Dynamic characteristics; typical values; $T_j = 25^\circ\text{C}$.

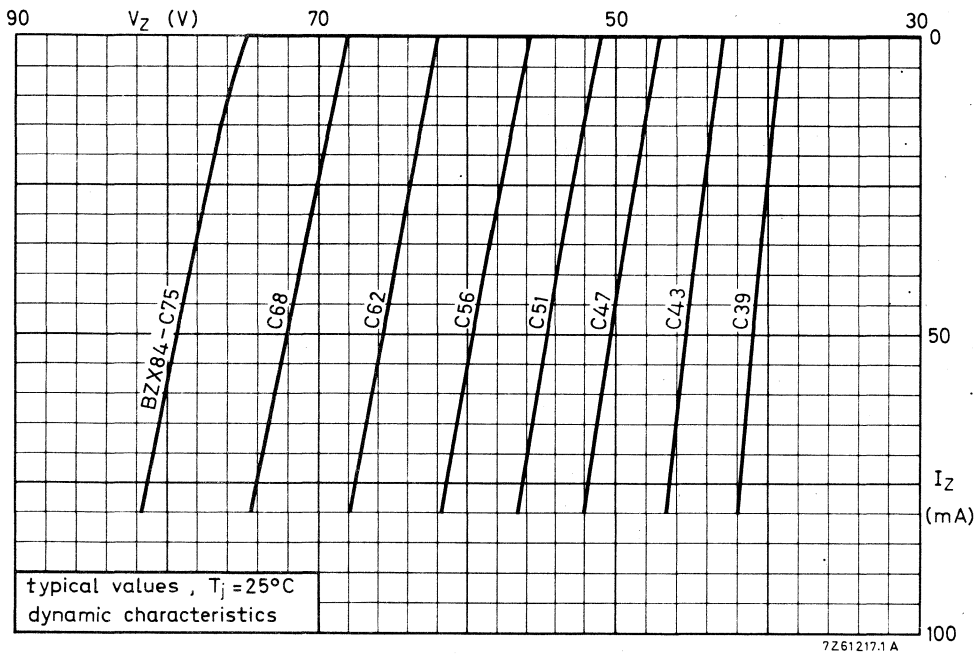

Fig. 6 Dynamic characteristics; typical values; $T_j = 25^\circ\text{C}$.

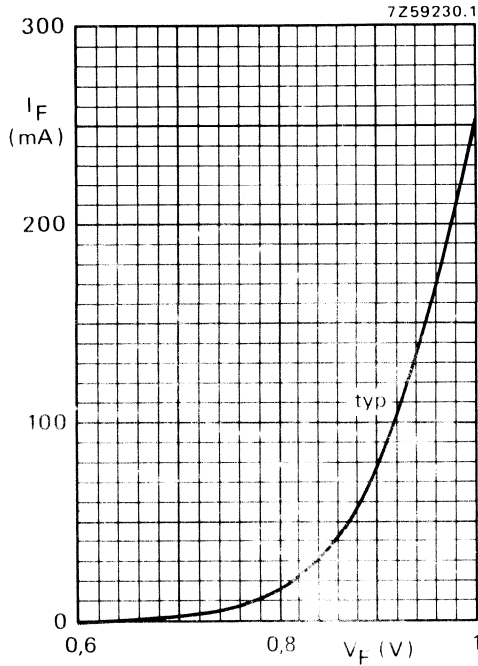

Fig. 7 Typical values at $T_j = 25\text{ }^\circ\text{C}$.

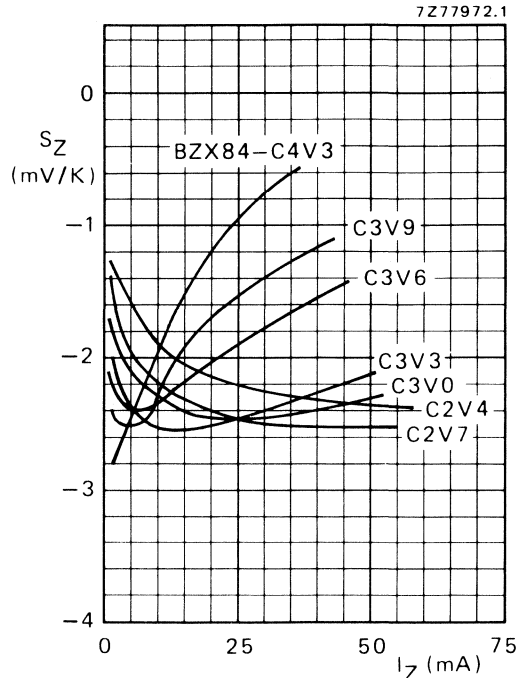

Fig. 8 Typical values; $T_j = 25\text{ to }175\text{ }^\circ\text{C}$.

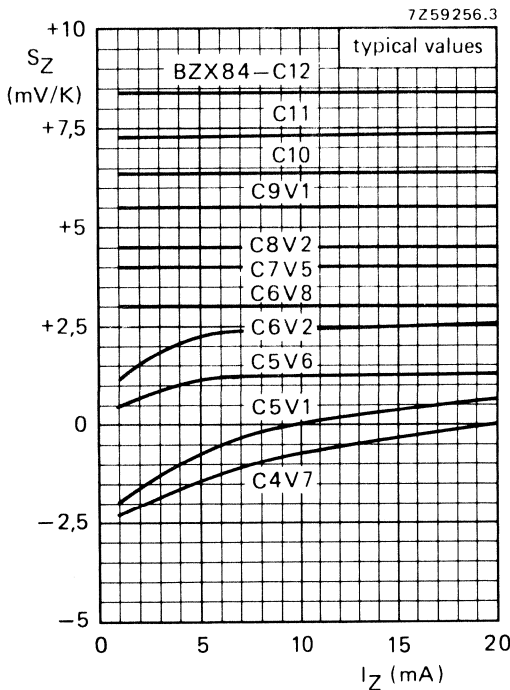

Fig. 9 Typical values; $T_j = 25\text{ to }175\text{ }^\circ\text{C}$.

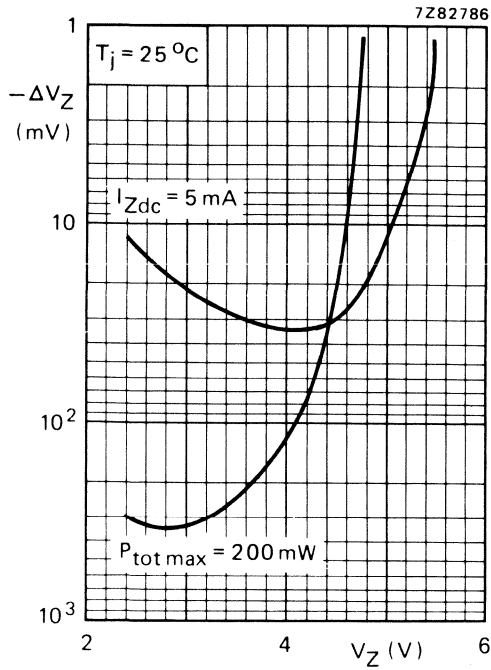

Fig. 10.

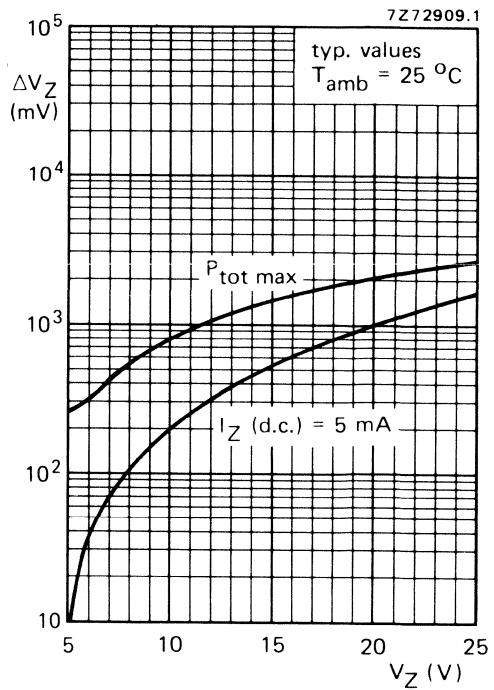

Fig. 11.

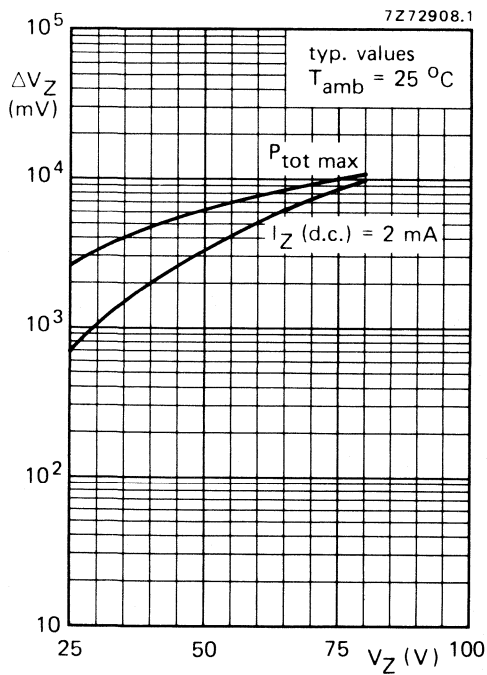

Fig. 12.

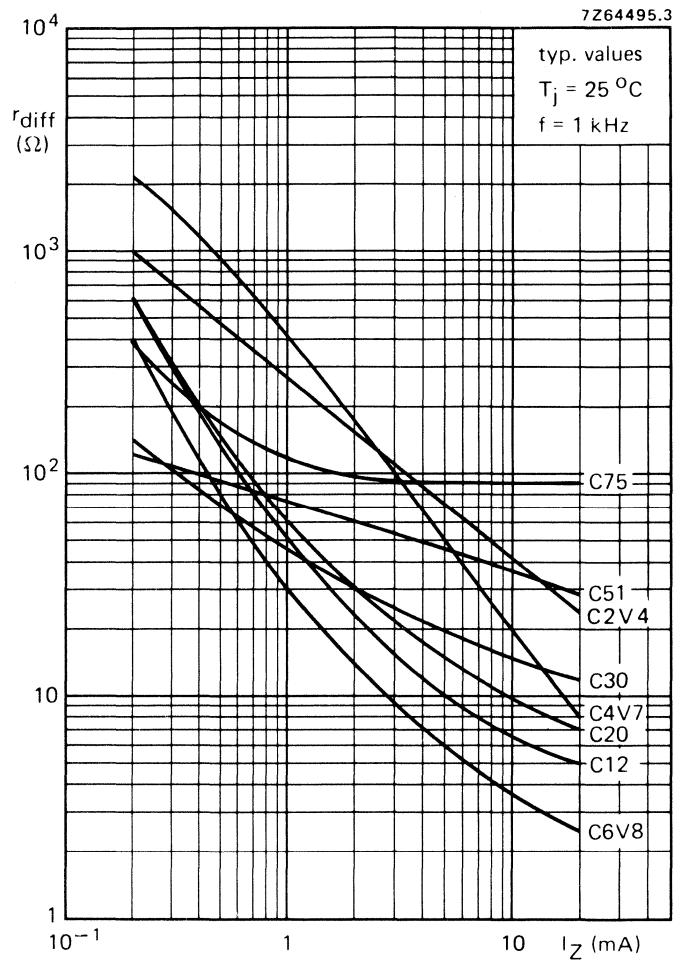

Fig. 13.

N-CHANNEL FETS

Silicon n-channel depletion type junction field-effect transistors on a plastic microminiature envelope intended for application in thick and thin-film circuits. The transistors are intended for low-power, chopper or switching applications in industry.

QUICK REFERENCE DATA

		PMBF4391	PMBF4392	PMBF4393
Drain-source voltage	$\pm V_{DS}$ max.	40	40	40 V
Drain current	I_{DSS}	> 50	25	5 mA
Gate-source cut-off voltage	$-V_{(P)GS}$	> 4	2	0,5 V
		< 10	5	3 V
Drain-source resistance (on) at $f = 1$ kHz	$r_{ds(on)}$	< 30	60	100 Ω
Feedback capacitance at $f = 1$ MHz	C_{rs}	< 3,5	3,5	3,5 pF
Turn-off time	t_{off}			
$V_{DD} = 10$ V; $V_{GS} = 0$	$I_D = 12$ mA; $-V_{GSM} = 12$ V	< 20	—	— ns
$I_D = 6$ mA; $-V_{GSM} = 7$ V	t_{off}	< —	35	— ns
$I_D = 3$ mA; $-V_{GSM} = 5$ V	t_{off}	< —	—	50 ns

MECHANICAL DATA

Fig. 1 SOT-23.

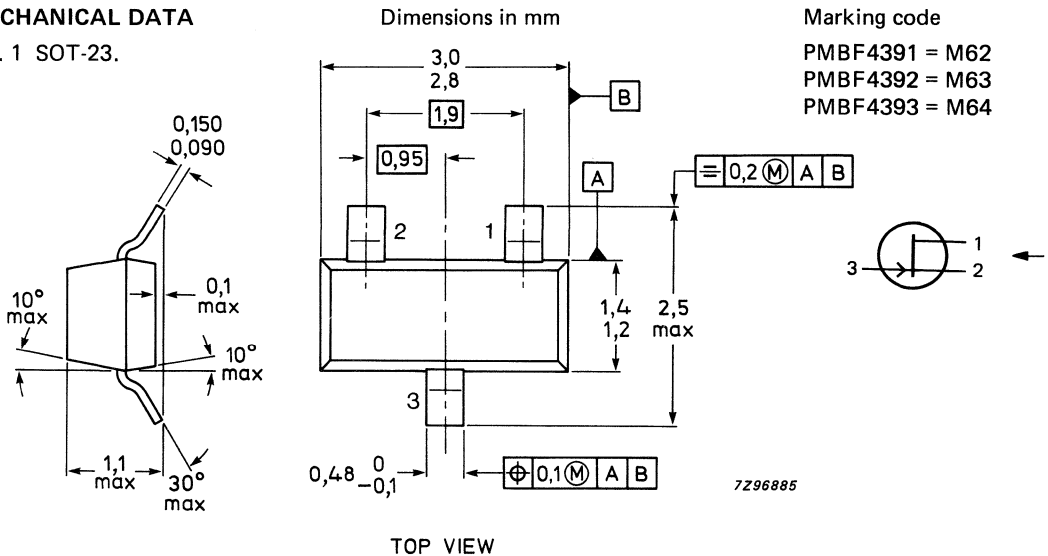

RATINGS

Limiting values in accordance with the Absolute Maximum System (IEC 134)

Drain-source voltage (See Fig. 4)	$\pm V_{DS}$	max.	40 V
Drain-gate voltage (See Fig. 4)	V_{DGO}	max.	40 V
Gate-source voltage (See Fig. 4)	$-V_{GSO}$	max.	40 V
Gate current (d.c.)	I_G	max.	50 mA
Total power dissipation up to $T_{amb} = 65^\circ\text{C}$	P_{tot}	max.	250 mW
Storage temperature range	T_{stg}		-65 to $+175^\circ\text{C}$
Junction temperature	T_j	max.	175°C

THERMAL CHARACTERISTICS

$$T_j = P (R_{th j-t} + R_{th t-s} + R_{th s-a}) + T_{amb}$$

Thermal resistance

From junction to tab	$R_{th j-t}$	=	60 K/W
From tab to soldering points	$R_{th t-s}$	=	260 K/W
From soldering points to ambient *	$R_{th s-a}$	=	120 K/W

CHARACTERISTICS

$T_{amb} = 25^\circ\text{C}$ unless otherwise specified

Gate-source voltage

$$I_G = 1 \text{ mA}; V_{DS} = 0 \quad V_{GSon} < 1 \text{ V}$$

Gate-source cut-off current

$$V_{DS} = 0 \text{ V}; -V_{GS} = 20 \text{ V} \quad -I_{GSS} < 1 \text{ nA}$$

$$V_{DS} = 0 \text{ V}; -V_{GS} = 20 \text{ V}; T_{amb} = 150^\circ\text{C} \quad -I_{GSS} < 0,2 \mu\text{A}$$

		PMBF4391	PMBF4392	PMBF4393	
Drain current** $V_{DS} = 20 \text{ V}; V_{GS} = 0$	I_{DSS}	> 50 < 150	25 75	5 mA 30 mA	
	Gate-source breakdown voltage $-I_G = 1 \mu\text{A}; V_{DS} = 0$	$-V_{(BR)GSS}$	> 40	40	40 V
Gate-source cut-off voltage $I_D = 1 \text{ nA}; V_{DS} = 20 \text{ V}$	Gate-source cut-off voltage	$-V_{(P)GS}$	> 4 < 10	2 5	0,5 V 3 V
		Drain-source voltage (on) $I_D = 12 \text{ mA}; V_{GS} = 0$	V_{DSon}	$< 0,4$	—
Drain-source voltage (on) $I_D = 6 \text{ mA}; V_{GS} = 0$	Drain-source voltage (on)	V_{DSon}	$< 0,4$	—	— V
		V_{DSon}	$< 0,4$	—	— V
Drain-source resistance (on) $I_D = 3 \text{ mA}; V_{GS} = 0$	Drain-source resistance (on)	$r_{ds on}$	< 30	60	100 Ω
		$r_{ds on}$	< 30	60	100 Ω

* Mounted on a ceramic substrate of 7 mm x 5 mm x 0,7 mm.

** Measured under pulsed conditions; $t_p = 100 \mu\text{s}$; $\delta = 0,01$.

		PMBF4391	PMBF4392	PMBF4393	
Drain cut-off current	$-V_{GS} = 12\text{ V}$ $-V_{GS} = 7\text{ V}$ $-V_{GS} = 5\text{ V}$	$V_{DS} = 20\text{ V}$ I_{DSX} I_{DSX} I_{DSX}	< 1	—	— nA
			< —	1	— nA
			< —	—	1 nA
	$-V_{GS} = 12\text{ V}$ $-V_{GS} = 7\text{ V}$ $-V_{GS} = 5\text{ V}$	$V_{DS} = 20\text{ V}; T_{amb} = 150^\circ\text{C}$ I_{DSX} I_{DSX} I_{DSX}	< 0,2	—	— μA
			< —	0,2	— μA
			< —	—	0,2 μA
y-parameters (common source)					
$V_{DS} = 20\text{ V}; V_{GS} = 0; f = 1\text{ MHz}$					
Input capacitance		C_{is}	< 14	14	14 pF
Feedback capacitance		C_{rs}	< 3,5	3,5	3,5 pF
Switching times					
$V_{DD} = 10\text{ V}; V_{GS} = 0$					
Conditions I_D and $-V_{GSM}$		I_D	= 12	6	3 mA
		$-V_{GSM}$	= 12	7	5 V
Rise time		t_r	< 5	5	5 ns
Turn on time		t_{on}	< 15	15	15 ns
Fall time		t_f	< 15	20	30 ns
Turn off time		t_{off}	< 20	35	50 ns

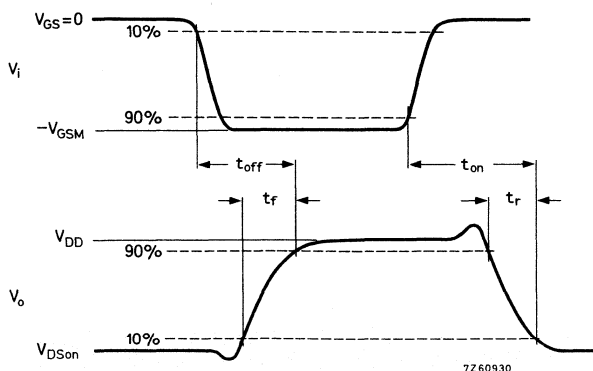
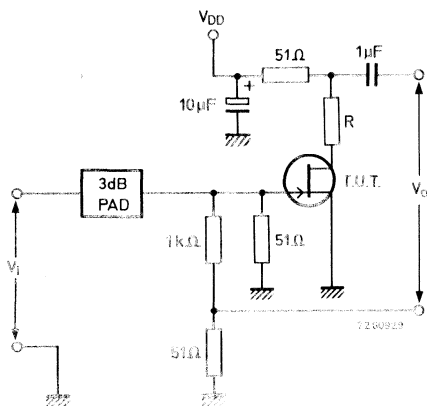

Fig. 2 Switching times waveforms.



$$R = \frac{9,6}{I_D} - 51 \Omega$$

Pulse generator:

$$t_r < 0,5 \text{ ns}$$

$$t_f < 0,5 \text{ ns}$$

$$t_p = 100 \mu\text{s}$$

$$\delta = 0,01$$

Oscilloscope:

$$R_i = 50 \Omega$$

Fig. 3 Test circuit.

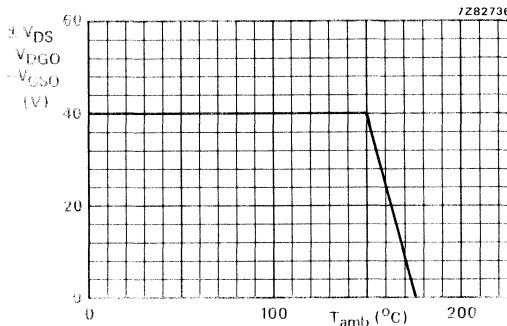

Fig. 4 Voltage derating curve.

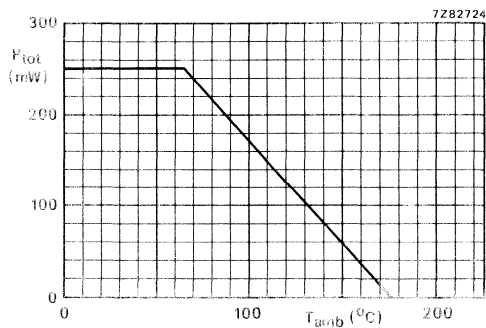

Fig. 5 Power derating curve.

SILICON PLANAR EPITAXIAL TRANSISTORS

N-P-N silicon transistors, in a microminiature plastic envelope intended for switching and linear applications in thick and thin-film circuits.

QUICK REFERENCE DATA

		PMBT2222	PMBT2222A
Collector-base voltage (open emitter)	V_{CBO} max.	60	75 V
Collector-emitter voltage (open base)	V_{CEO} max.	30	40 V
Emitter-base voltage (open collector)	V_{EBO} max.	5,0	6,0 V
Collector current (d.c.)	I_C max.	600	mA
Total power dissipation up to $T_{amb} = 25\text{ }^\circ\text{C}$	P_{tot} max.	350	mW
D.C. current gain			
$I_C = 150\text{ mA}; V_{CE} = 10\text{ V}$	h_{FE}	100 to 300	
$I_C = 500\text{ mA}; V_{CE} = 10\text{ V}$	$h_{FE} >$	30	40
Transition frequency at $f = 100\text{ MHz}$			
$I_C = 20\text{ mA}; V_{CE} = 20\text{ V}$	$f_T >$	250	300 MHz

MECHANICAL DATA

Dimensions in mm

Fig. 1 SOT-23.

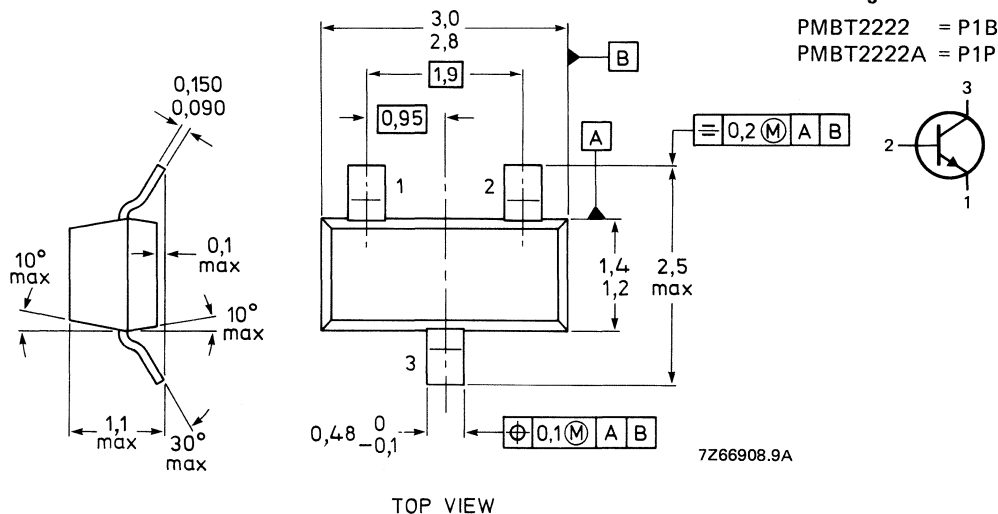

RATINGS

Limiting values in accordance with the Absolute Maximum System (IEC 134)

		PMBT2222	PMBT2222A	
Collector-base voltage (open emitter) see Fig. 4	V_{CBO}	max. 60	75	V
Collector-emitter voltage (open base) see Fig. 4	V_{CEO}	max. 30	40	V
Emitter-base voltage (open collector) see Fig. 4	V_{EBO}	max. 5,0	6,0	V
Collector current (d.c.)	I_C	max. 600		mA
Total power dissipation* up to $T_{amb} = 25\text{ }^\circ\text{C}$	P_{tot}	max. 350		mW
Storage temperature range	T_{stg}		-55 to 150	$^\circ\text{C}$
Junction temperature	T_j	max. 150		$^\circ\text{C}$

THERMAL RESISTANCE *

From junction to ambient	$R_{th\ j-a}$	=	350	K/W
--------------------------	---------------	---	-----	-----

CHARACTERISTICS

$T_j = 25\text{ }^\circ\text{C}$ unless otherwise specified

		PMBT2222	PMBT2222A	
Collector cut-off current $I_E = 0; V_{CB} = 50\text{ V}$	I_{CBO}	< 0,01	—	μA
$I_E = 0; V_{CB} = 60\text{ V}$	I_{CBO}	< —	0,01	μA
$I_E = 0; V_{CB} = 50\text{ V}; T_j = 125\text{ }^\circ\text{C}$	I_{CBO}	< 10	—	μA
$I_E = 0; V_{CB} = 60\text{ V}; T_j = 125\text{ }^\circ\text{C}$	I_{CBO}	< —	10	μA
$V_{EB} = 3\text{ V}; V_{CE} = 60\text{ V}$	I_{CEX}	< —	10	nA
Base current with reverse biased emitter junction $V_{EB} = 3\text{ V}; V_{CE} = 60\text{ V}$	I_{BEX}	< —	20	nA
Emitter cut-off current $I_C = 0; V_{EB} = 3\text{ V}$	I_{EBO}	< —	10	nA
Saturation voltages** $I_C = 150\text{ mA}; I_B = 15\text{ mA}$	V_{CEsat}	< 400	300	mV
	V_{BEsat}	< 1300	—	mV
	V_{BEsat}	—	0,6 to 1,2	V
$I_C = 500\text{ mA}; I_B = 50\text{ mA}$	V_{CEsat}	< 1600	1000	mV
	V_{BEsat}	< 2600	2000	mV
Breakdown voltages $I_C = 1,0\text{ mA}; I_B = 0$	$V_{(BR)CEO}$	> 30	40	V
$I_C = 100\text{ } \mu\text{A}; I_E = 0$	$V_{(BR)CBO}$	> 60	75	V
$I_C = 0; I_E = 10\text{ } \mu\text{A}$	$V_{(BR)EBO}$	> 5,0	6,0	V

* Device mounted on a ceramic substrate of 15 mm x 15 mm x 0,7 mm.

** Measured under pulsed conditions to avoid excessive dissipation; $t_p \leq 300\text{ } \mu\text{s}; \delta \leq 0,02$.

		PMBT2222	PMBT2222A	
D.C. current gain				
$I_C = 0,1 \text{ mA}; V_{CE} = 10 \text{ V}$	h_{FE}	>	35	
$I_C = 1 \text{ mA}; V_{CE} = 10 \text{ V}$	h_{FE}	>	50	
$I_C = 10 \text{ mA}; V_{CE} = 10 \text{ V}$	h_{FE}	>	75	
$I_C = 10 \text{ mA}; V_{CE} = 10 \text{ V}; T_{amb} = -55 \text{ }^\circ\text{C}$	h_{FE}	>	35	
$I_C = 150 \text{ mA}; V_{CE} = 10 \text{ V}$	h_{FE}	>	100 to 300	
$I_C = 150 \text{ mA}; V_{CE} = 1 \text{ V}$	h_{FE}	>	50	
$I_C = 500 \text{ mA}; V_{CE} = 10 \text{ V}$	h_{FE}	>	30	40
Transition frequency at $f = 100 \text{ MHz}^*$				
$I_C = 20 \text{ mA}; V_{CE} = 20 \text{ V}$	f_T	>	250	300 MHz
Output capacitance at $f = 1 \text{ MHz}$				
$I_E = 0; V_{CB} = 10 \text{ V}$	C_o	<	8,0	pF
Input capacitance at $f = 1 \text{ MHz}$				
$I_C = 0; V_{EB} = 0,5 \text{ V}$	C_i	<	30	25
h-parameters (common emitter) at $f = 1 \text{ kHz}$				
$I_C = 1 \text{ mA}; V_{CE} = 10 \text{ V}$				
input impedance	h_{ie}		2,0 to 8,0	k Ω
reverse voltage transfer ratio	h_{re}		$< 8,0 \times 10^{-4}$	
small signal current gain	h_{fe}		50 to 300	
output admittance	h_{oe}		5,0 to 35	μS
$I_C = 10 \text{ mA}; V_{CE} = 10 \text{ V}$				
input impedance	h_{ie}		0,25 to 1,25	k Ω
reverse voltage transfer ratio	h_{re}		$< 4,0 \times 10^{-4}$	
small signal current gain	h_{fe}		75 to 375	
output admittance	h_{oe}		25 to 200	μS
Noise figure at $R_S = 1 \text{ k}\Omega$				
$I_C = 100 \text{ } \mu\text{A}; V_{CE} = 10 \text{ V}; f = 1 \text{ kHz}$	F		4,0	dB
Switching times (between 10% and 90% levels)				
Turn-on time switched to $I_C = 150 \text{ mA}$				
delay time	t_d	<	10	ns
rise time	t_r	<	25	ns
Turn-off time switched from $I_C = 150 \text{ mA}$				
storage time	t_s	<	225	ns
fall time	t_f	<	60	ns

* f_T is defined as the frequency at which h_{fe} extrapolates to unity.

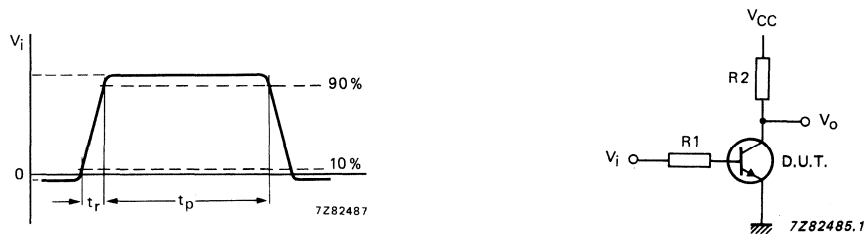

Fig. 2 Waveform and test circuit delay and rise time.

$V_i = -0,5$ to $+9,9$ V; $V_{CC} = 30$ V; $R_1 = 619 \Omega$; $R_2 = 200 \Omega$.

Pulse generator:

pulse duration $t_p \leq 200$ ns
 rise time $t_r \leq 2$ ns
 duty factor $\delta = 2\%$

Oscilloscope:

input impedance $Z_i > 100$ k Ω
 input capacitance $C_i < 12$ pF
 rise time $t_r < 5$ ns

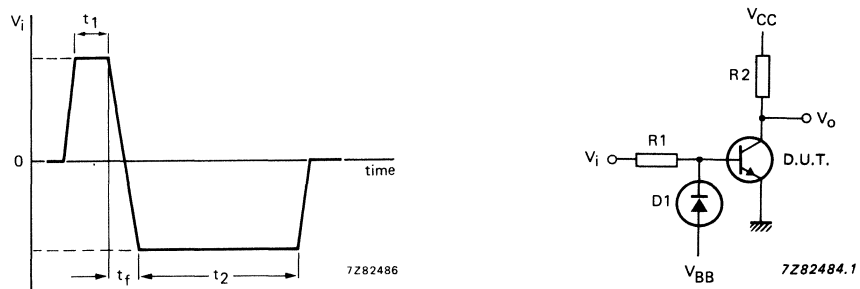

Fig. 3 Waveform and test circuit storage and fall time.

$V_i = -13,8$ to $+16,2$ V; $V_{CC} = 30$ V; $-V_{BB} = 3$ V; $R_1 = 1$ k Ω ; $R_2 = 200 \Omega$.

Pulse generator:

fall time $t_f < 5$ ns
 pulse time $t_1 = 100$ μ s
 $t_2 = 500$ μ s

Oscilloscope:

input impedance $Z_i > 100$ k Ω
 input capacitance $C_i < 12$ pF
 rise time $t_r < 5$ ns

SILICON PLANAR EPITAXIAL TRANSISTORS

P-N-P silicon transistors, in a microminiature plastic envelope, intended for medium power switching and general purpose amplifier applications in thick and thin-film circuits.

QUICK REFERENCE DATA

		PMBT2907		PMBT2907A	
Collector-base voltage (open emitter)	$-V_{CBO}$	max.	60	60	V
Collector-emitter voltage (open base)	$-V_{CEO}$	max.	40	60	V
Emitter-base voltage (open collector)	$-V_{EBO}$	max.		5,0	V
Collector current (d.c.)	$-I_C$	max.	600		mA
Total power dissipation up to $T_{amb} = 25\text{ }^\circ\text{C}$	P_{tot}	max.	350		mW
Junction temperature	T_j	max.	150		$^\circ\text{C}$
D.C. current gain					
$-I_C = 500\text{ mA}; -V_{CE} = 10\text{ V}$	h_{FE}	>	30	50	
Turn-off switching time					
$-I_{Con} = 150\text{ mA}; -I_{Bon} = I_{Boff} = 15\text{ mA}$	t_{off}	<	100		ns
Transition frequency at $f = 100\text{ MHz}$					
$-I_C = 50\text{ mA}; -V_{CE} = 20\text{ V}$	f_T	>	200		MHz

MECHANICAL DATA

Dimensions in mm

Fig. 1 SOT-23.

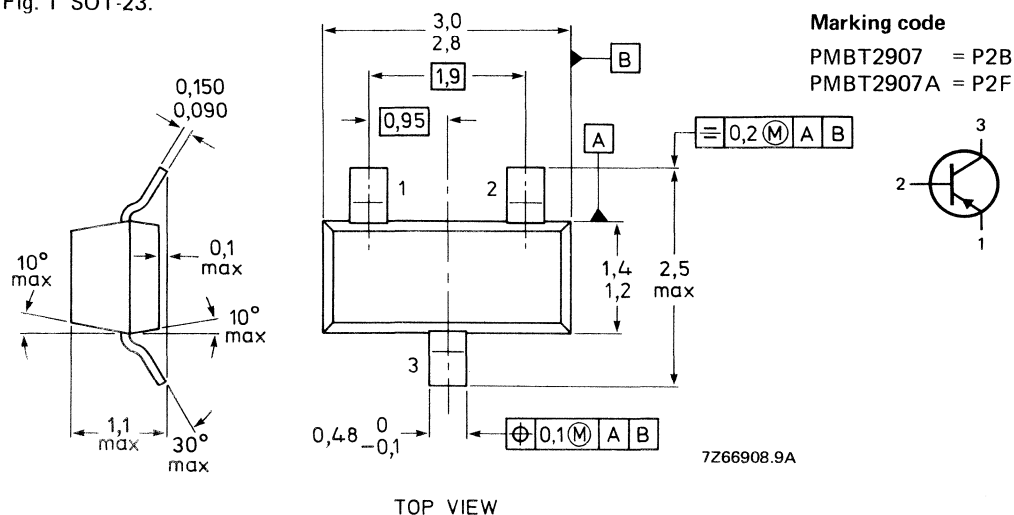

RATINGS

Limiting values in accordance with the Absolute Maximum System (IEC 134)

		PMBT2907	PMBT2907A
Collector-base voltage (open emitter) see Figs 4 and 5	$-V_{CBO}$	max. 60	60 V
Collector-emitter voltage (open base) see Figs 4 and 5	$-V_{CEO}$	max. 40	60 V
Emitter-base voltage (open collector) see Figs 4 and 5	$-V_{EBO}$	max. 5,0	V
Collector current (d.c.)	$-I_C$	max. 600	mA
Power dissipation up to $T_{amb} = 25\text{ }^\circ\text{C}$	P_{tot}	max. 350	mW
Storage temperature range	T_{stg}	-65 to +150	$^\circ\text{C}$
Junction temperature	T_j	max. 150	$^\circ\text{C}$

THERMAL RESISTANCE *

From junction to ambient in free air	$R_{th\ j-a}$	=	350	K/W
--------------------------------------	---------------	---	-----	-----

CHARACTERISTICS

$T_j = 25\text{ }^\circ\text{C}$ unless otherwise specified

		PMBT2907	PMBT2907A
Collector cut-off current $I_E = 0; -V_{CB} = 50\text{ V}$	$-I_{CBO}$	< 20	10 nA
$I_E = 0; -V_{CB} = 50\text{ V}; T_j = 125\text{ }^\circ\text{C}$	$-I_{CBO}$	< 20	10 μA
$-V_{EB} = 0,5\text{ V}; -V_{CE} = 30\text{ V}$	$-I_{CEX}$	< 50	nA
Base current with reverse biased emitter junction $-V_{EB} = 3\text{ V}; -V_{CE} = 30\text{ V}$	$-I_{BEX}$	< 50	nA
Saturation voltages** $-I_C = 150\text{ mA}; -I_B = 15\text{ mA}$	$-V_{CEsat}$	< 0,4	V
	$-V_{BEsat}$	< 1,3	V
$-I_C = 500\text{ mA}; -I_B = 50\text{ mA}$	$-V_{CEsat}$	< 1,6	V
	$-V_{BEsat}$	< 2,6	V
Collector-base breakdown voltage open emitter; $-I_C = 10\text{ }\mu\text{A}; I_E = 0$	$-V_{(BR)CBO}$	60	V
Collector-emitter breakdown voltage open base; $-I_C = 10\text{ mA}; I_B = 0$	$-V_{(BR)CEO}$	> 40	60 V
Emitter-base breakdown voltage open collector; $-I_E = 10\text{ }\mu\text{A}; I_C = 0$	$-V_{(BR)EBO}$	5,0	V

* Device mounted on a ceramic substrate of 15 mm x 15 mm x 0,7 mm.

		PMBT2907	PMBT2907A
D.C. current gain			
$-I_C = 0,1 \text{ mA}; -V_{CE} = 10 \text{ V}$	$h_{FE} >$	35	75
$-I_C = 1 \text{ mA}; -V_{CE} = 10 \text{ V}$	$h_{FE} >$	50	100
$-I_C = 10 \text{ mA}; -V_{CE} = 10 \text{ V}$	$h_{FE} >$	75	100
$-I_C = 150 \text{ mA}; -V_{CE} = 10 \text{ V}$	$h_{FE} >$	100 to 300	
$-I_C = 500 \text{ mA}; -V_{CE} = 10 \text{ V}$	$h_{FE} >$	30	50
Transition frequency at $f = 100 \text{ MHz}$			
$-I_C = 50 \text{ mA}; -V_{CE} = 20 \text{ V}; T_{amb} = 25 \text{ }^\circ\text{C}$	$f_T >$	200	MHz
Output capacitance at $f = 1 \text{ MHz}$			
$I_E = I_e = 0; -V_{CB} = 10 \text{ V}$	$C_o <$	8,0	pF
Input capacitance at $f = 1 \text{ MHz}$			
$I_C = I_c = 0; -V_{EB} = 2 \text{ V}$	$C_i <$	30	pF
Switching times (between 10% and 90% levels)			
Turn-on time when switched to			
$-I_C = 150 \text{ mA}; -I_B = 15 \text{ mA}; V_{CC} = 30 \text{ V}$			
delay time	$t_d <$	10	ns
rise time	$t_r <$	40	ns
turn-on time ($t_d + t_r$)	$t_{on} <$	45	ns
Turn-off time when switched from			
$-I_C = 150 \text{ mA}; -I_B = 15 \text{ mA}; V_{CC} = 6 \text{ V}$			
to cut-off with $+I_{BM} = 15 \text{ mA}$ (see Fig. 3)			
storage time	$t_s <$	80	ns
fall time	$t_f <$	30	ns
turn-off time ($t_s + t_f$)	$t_{off} <$	100	ns

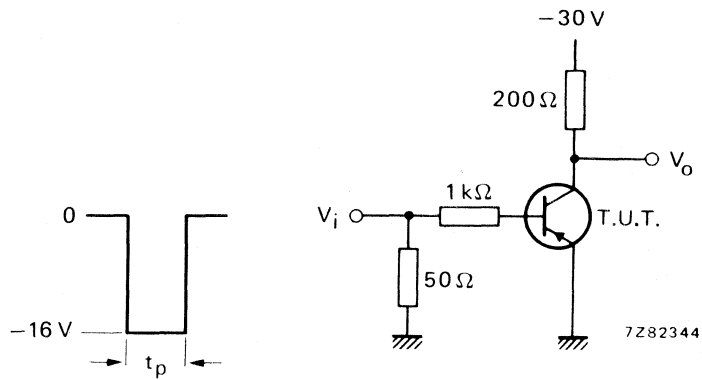

Fig. 2 Turn-on switching time test circuit.

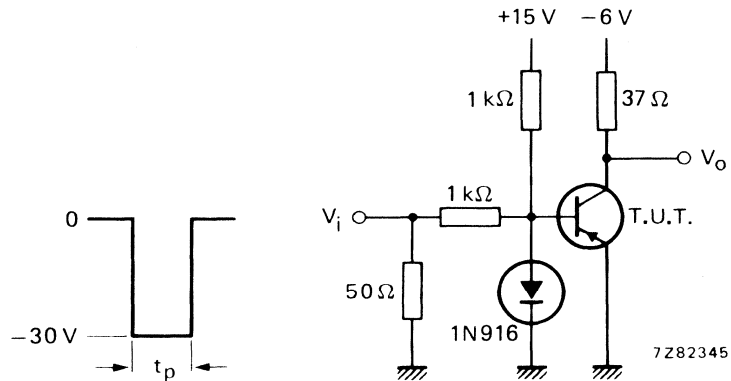

Fig. 3 Turn-off switching time test circuit.

Input pulse generator: Fig. 2 and Fig. 3	frequency	f	=	150	Hz
	pulse duration	t_p	=	200	ns
	rise time	t_r	\leq	2	ns
	output impedance	Z_o	=	50	Ω
Output oscilloscope: Fig. 2 and Fig. 3	rise time	t_r	\leq	5	ns
	input impedance	Z_i	=	10	M Ω

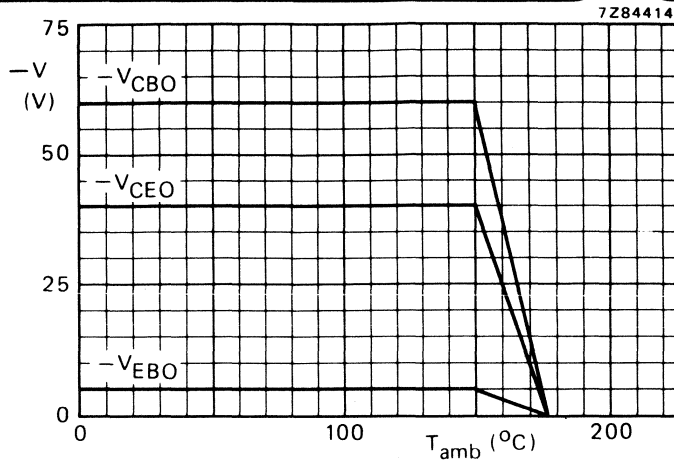

Fig. 4 Voltage derating curves PMBT2907.

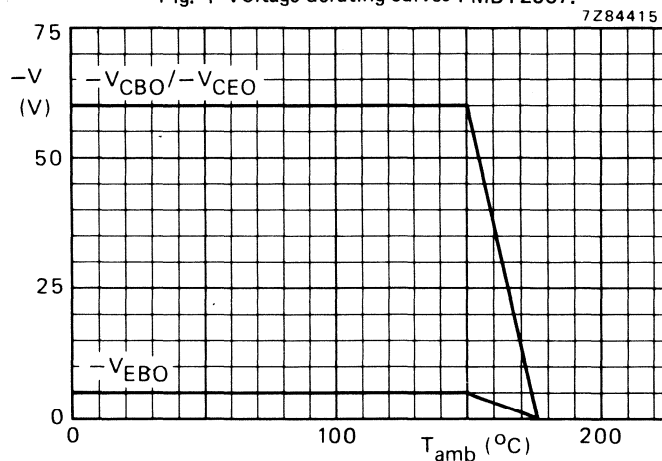

Fig. 5 Voltage derating curves PMBT2907A.

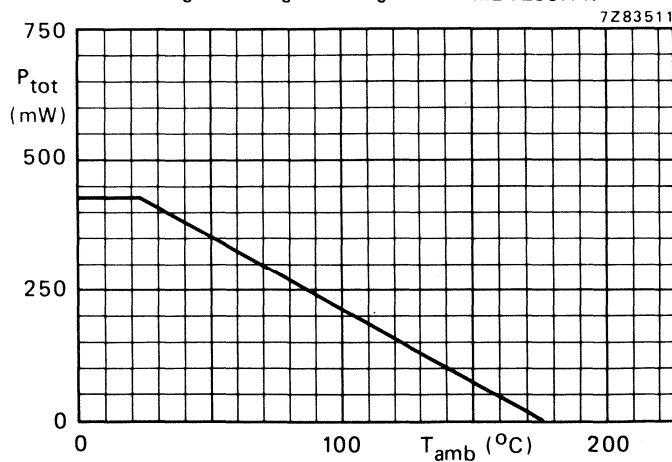

Fig. 6 Power derating curve PMBT2907/A.

SILICON EPITAXIAL TRANSISTORS

N-P-N transistors in a microminiature (SMD) plastic envelope intended for surface mounted applications. They are primarily intended for use in telephony and professional communication equipment.

QUICK REFERENCE DATA

		PMBT3903	PMBT3904
Collector-base voltage (open emitter)	V_{CB0} max.	60	V
Collector-emitter voltage (open base)	V_{CE0} max.	40	V
Emitter-base voltage (open collector)	V_{EB0} max.	6	V
Collector current (d.c.)	I_C max.	200	mA
Total power dissipation up to $T_{amb} = 25\text{ }^\circ\text{C}$	P_{tot} max.	300	mW
D.C. current gain $I_C = 10\text{ mA}; V_{CE} = 1\text{ V}$	$h_{FE} >$	50	100
	$h_{FE} <$	150	300
Transition frequency at $f = 35\text{ MHz}$ $I_C = 10\text{ mA}; V_{CE} = 20\text{ V}$	$f_T >$	250	300 MHz

MECHANICAL DATA

Fig. 1 SOT-23.

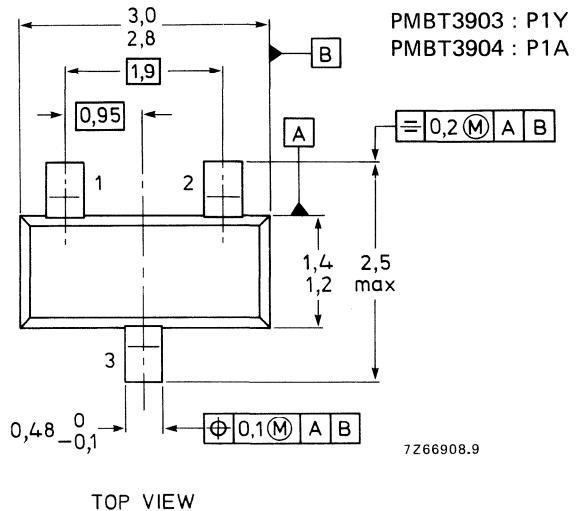
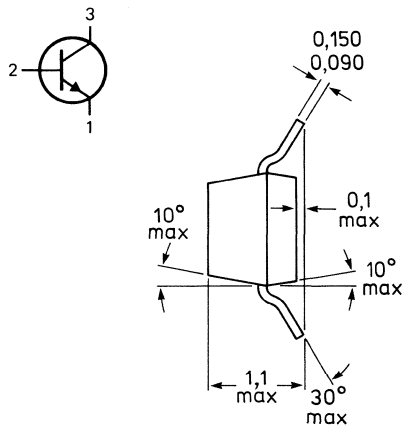

See also Soldering recommendations.

RATINGS

Limiting values in accordance with the Absolute Maximum System (IEC 134)

Collector-base voltage (open emitter)	V_{CBO}	max.	60	V
Collector-emitter voltage (open base)	V_{CEO}	max.	40	V
Emitter-base voltage (open collector)	V_{EBO}	max.	6	V
Collector current (d.c.)	I_C	max.	200	mA
Total power dissipation* up to $T_{amb} = 25\text{ }^\circ\text{C}$	P_{tot}	max.	300	mW
Storage temperature	T_{stg}		-65 to +150	$^\circ\text{C}$
Junction temperature	T_j	max.	150	$^\circ\text{C}$

THERMAL RESISTANCE**

$$T_j = P (R_{th\ j-t} + R_{th\ t-s} + R_{th\ s-a}) + T_{amb}$$

Thermal resistance

from junction to ambient*

$R_{th\ j-a}$	=	430	K/W
---------------	---	-----	-----

CHARACTERISTICS

$T_{amb} = 25\text{ }^\circ\text{C}$ unless otherwise specified

Collector-emitter breakdown voltage [▲] $I_C = 1\text{ mA}; I_B = 0$	$V_{(BR)CEO}$	min.	40	V
Collector-base breakdown voltage $I_C = 10\text{ }\mu\text{A}; I_E = 0$	$V_{(BR)CBO}$	min.	60	V
Emitter-base breakdown voltage $I_E = 10\text{ }\mu\text{A}; I_C = 0$	$V_{(BR)EBO}$	min.	6	V
Collector cut-off current $V_{CE} = 30\text{ V}; V_{EB} = 3\text{ V}$	I_{CEX}	max.	50	nA
Output capacitance at $f = 1\text{ MHz}$ $I_E = 0; V_{CB} = 5\text{ V}$	C_c	max.	4	pF
Input capacitance at $f = 1\text{ MHz}$ $I_C = 0; V_{BE} = 0,5\text{ V}$	C_e	max.	8	pF
Base current with reverse biased emitter junction $V_{EB} = 3\text{ V}; V_{CE} = 30\text{ V}$	I_{BEX}	max.	50	nA

* Mounted on a ceramic substrate: area = $10 \times 8\text{ mm}^2$; thickness = 0,7 mm.

** See Thermal characteristics.

▲ Pulse test conditions: $t_p = 300\text{ }\mu\text{s}$; duty cycle $\leq 2\%$.

		PMBT3903	PMBT3904
Saturation voltages			
$I_C = 10 \text{ mA}; I_B = 1 \text{ mA}$	V_{CEsat} max.	0,2	V
$I_C = 50 \text{ mA}; I_B = 5 \text{ mA}$	V_{CEsat} max.	0,3	V
$I_C = 10 \text{ mA}; I_B = 1 \text{ mA}$	V_{BEsat} min.	0,65	V
$I_C = 50 \text{ mA}; I_B = 5 \text{ mA}$	V_{BEsat} max.	0,85	V
$I_C = 10 \text{ mA}; I_B = 1 \text{ mA}$	V_{BEsat} max.	0,95	V
D.C. current gain *			
$I_C = 0,1 \text{ mA}; V_{CE} = 1 \text{ V}$	h_{FE} >	20	40
$I_C = 1 \text{ mA}; V_{CE} = 1 \text{ V}$	h_{FE} >	35	70
$I_C = 10 \text{ mA}; V_{CE} = 1 \text{ V}$	h_{FE} >	50	100
$I_C = 50 \text{ mA}; V_{CE} = 1 \text{ V}$	h_{FE} <	150	300
$I_C = 10 \text{ mA}; V_{CE} = 1 \text{ V}$	h_{FE} >	30	60
$I_C = 100 \text{ mA}; V_{CE} = 1 \text{ V}$	h_{FE} >	15	30
Transition frequency at $f = 100 \text{ MHz}$			
$I_C = 10 \text{ mA}; V_{CE} = 20 \text{ V}$	f_T min.	250	300 MHz
Noise figure at $R_S = 1 \text{ k}\Omega$			
$I_C = 100 \mu\text{A}; V_{CE} = 5 \text{ V}$			
$f = 10 \text{ Hz to } 15,7 \text{ kHz}$	F max.	6	5 dB
h-parameters (common emitter)			
$I_C = 1 \text{ mA}; V_{CE} = 10 \text{ V}; f = 1 \text{ kHz}$			
Input impedance	h_{ie}	1 to 8	1 to 10 $\text{k}\Omega$
Reverse voltage transfer ratio	h_{re}	0,1 to 5	$0,5 \text{ to } 8 \cdot 10^{-4}$
Small-signal current gain	h_{fe}	50 to 200	100 to 400
Output admittance	h_{oe}	1 to 40	1 to 40 μS
Switching times			
Turn-on time when $V_{CC} = 3 \text{ V}; V_{BE} = 0,5 \text{ V}$			
$I_C = 10 \text{ mA}; I_{Bon} = 1 \text{ mA}$			
Delay time	t_d <	35	35 ns
Rise time	t_r <	35	35 ns
Turn-off time when $V_{CC} = 3 \text{ V}; I_C = 10 \text{ mA}$			
$I_{Bon} = I_{Boff} = 1 \text{ mA}$			
Storage time	t_s <	175	200 ns
Fall time	t_f <	50	50 ns

* Pulse test conditions: $t_p = 300 \mu\text{s}$; duty cycle $\leq 2\%$.

SILICON EPITAXIAL TRANSISTOR

P-N-P transistor in a microminiature (SMD) plastic envelope intended for surface mounted applications. The PMBT3906 is primarily intended for use in telephony and professional communication equipment.

QUICK REFERENCE DATA

Collector-base voltage (open emitter)	$-V_{CBO}$	max.	40 V
Collector-emitter voltage (open base)	$-V_{CEO}$	max.	40 V
Emitter-base voltage (open collector)	$-V_{EBO}$	max.	5 V
Collector current (d.c.)	$-I_C$	max.	200 mA
Total power dissipation up to $T_{amb} = 25\text{ }^\circ\text{C}$	P_{tot}	max.	300 mW
D.C. current gain	h_{FE}		100 to 300
$-I_C = 10\text{ mA}; -V_{CE} = 1\text{ V}$			
Transition frequency at $f = 100\text{ MHz}$	f_T	min.	250 MHz
$-I_C = 10\text{ mA}; -V_{CE} = 20\text{ V}$			

MECHANICAL DATA

Fig. 1 SOT-23.

Dimensions in mm

Marking code

PMBT3906 : P2A

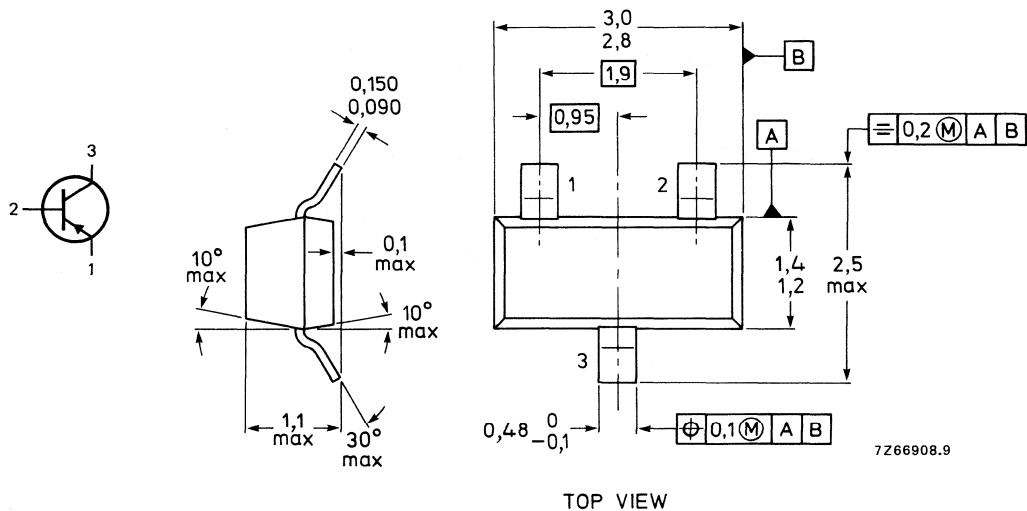

See also Soldering recommendations.

RATINGS

Limiting values in accordance with the Absolute Maximum System (IEC 134)

Collector-base voltage (open emitter)	$-V_{CBO}$	max.	40 V
Collector-emitter voltage (open base)	$-V_{CEO}$	max.	40 V
Emitter-base voltage (open collector)	$-V_{EBO}$	max.	5 V
Collector current (d.c.)	$-I_C$	max.	200 mA
Total power dissipation* up to $T_{amb} = 25\text{ }^\circ\text{C}$	P_{tot}	max.	300 mW
Storage temperature	T_{stg}		-55 to +150 $^\circ\text{C}$

THERMAL CHARACTERISTICS**

$$T_j = P(R_{th\ j-t} + R_{th\ t-s} + R_{th\ s-a}) + T_{amb}$$

Thermal resistance

from junction to ambient

$$R_{th\ j-a} = 420\text{ K/W}$$

CHARACTERISTICS

$T_{amb} = 25\text{ }^\circ\text{C}$ unless otherwise specified

Collector-emitter breakdown voltage \blacktriangle

$-I_C = 1\text{ mA}; I_B = 0$

$$-V_{(BR)CEO} \text{ min. } 40\text{ V}$$

Collector-base breakdown voltage

$-I_C = 10\text{ }\mu\text{A}; I_E = 0$

$$-V_{(BR)CBO} \text{ min. } 40\text{ V}$$

Emitter-base breakdown voltage

$-I_E = 10\text{ }\mu\text{A}; I_C = 0$

$$-V_{(BR)EBO} \text{ min. } 5\text{ V}$$

Collector cut-off current

$-V_{CE} = 30\text{ V}; -V_{EB} = 3\text{ V}$

$$-I_{CE} \text{ max. } 50\text{ nA}$$

Base current

with reverse biased emitter junction

$$-I_{BEX} \text{ max. } 50\text{ nA}$$

Output capacitance at $f = 100\text{ kHz}$

$I_E = 0; -V_{CB} = 5\text{ V}$

$$C_c \text{ max. } 4,5\text{ pF}$$

Input capacitance at $f = 100\text{ kHz}$

$I_C = 0; -V_{BE} = 0,5\text{ V}$

$$C_e \text{ max. } 10\text{ pF}$$

* Mounted on a ceramic substrate: area = 10 x 8 mm; thickness = 0,7 mm.

** See Thermal characteristics.

\blacktriangle Pulse test conditions: $t_p = 300\text{ }\mu\text{s};$ duty cycle $\leq 2\%$.

Saturation voltages			
$-I_C = 10 \text{ mA}; -I_B = 1 \text{ mA}$	$-V_{CEsat}$	max.	0,25 V
$-I_C = 50 \text{ mA}; -I_B = 5 \text{ mA}$	$-V_{CEsat}$	max. min.	0,4 V 0,65 V
$-I_C = 10 \text{ mA}; -I_B = 1 \text{ mA}$	$-V_{BEsat}$	max.	0,85 V
$-I_C = 50 \text{ mA}; -I_B = 5 \text{ mA}$	$-V_{BBsat}$	max.	0,95 V
D.C. current gain			
$-I_C = 0,1 \text{ mA}; -V_{CE} = 1 \text{ V}$	h_{FE}	min.	60
$-I_C = 1 \text{ mA}; -V_{CE} = 1 \text{ V}$	h_{FE}	min.	80
$-I_C = 10 \text{ mA}; -V_{CE} = 1 \text{ V}$	h_{FE}	min. max.	100 300
$-I_C = 50 \text{ mA}; -V_{CE} = 1 \text{ V}$	h_{FE}	min.	60
$-I_C = 100 \text{ mA}; -V_{CE} = 1 \text{ V}$	h_{FE}	min.	30
Transition frequency at $f = 100 \text{ MHz}$			
$-I_C = 10 \text{ mA}; -V_{CE} = 20 \text{ V}$	f_T	min.	250 MHz
Noise figure at $R_S = 1 \text{ k}\Omega$			
$-I_C = 100 \mu\text{A}; -V_{CE} = 5 \text{ V}$ $f = 10 \text{ Hz to } 15,7 \text{ kHz}$	F	max.	4 dB
h-parameters (common emitter)			
$-I_C = 1 \text{ mA}; -V_{CE} = 10 \text{ V}; f = 1 \text{ kHz}$			
Input impedance			
	h_{ie}	min. max.	2,0 $\text{k}\Omega$ 12 $\text{k}\Omega$
Reverse voltage transfer ratio			
	h_{re}	min. max.	1,0 10^{-4} 10 10^{-4}
Small signal current gain			
	h_{fe}	min. max.	100 400
Output admittance			
	h_{oe}	min. max.	30 μS 60 μS
Switching times			
Turn-on time when $-V_{CC} = 3 \text{ V}; -V_{BE} = 0,5 \text{ V}$ $-I_C = 10 \text{ mA}; -I_{Bon} = 1 \text{ mA}$			
Delay time	t_d	max.	35 ns
Rise time	t_r	max.	35 ns
Turn-off time when $-V_{CC} = 3 \text{ V}; -I_C = 10 \text{ mA}$ $-I_{Bon} = -I_{Boff} = 1 \text{ mA}$			
Storage time	t_s	max.	225 ns
Fall time	t_f	max.	75 ns

SILICON EPITAXIAL TRANSISTORS

N-P-N transistors in a microminiature (SMD) plastic envelope intended for application in thick and thin-film circuits (Surface Mounted Device).

They are primarily intended for use in telephony and professional communication equipment.

QUICK REFERENCE DATA

		PMBT6428	PMBT6429
Collector-base voltage (open emitter)	V_{CBO}	max. 60	55 V
Collector-emitter voltage (open base)	V_{CEO}	max. 50	45 V
Collector current (d.c.)	I_C	max. 200	mA
Total power dissipation up to $T_{amb} = 25\text{ }^\circ\text{C}$	P_{tot}	max. 350	mW
D.C. current gain $I_C = 0,1\text{ mA}; V_{CE} = 5\text{ V}$	h_{FE}	min. 250 max. 650	500 1250
	h_{FE}	min. 250	500
Transition frequency at $f = 100\text{ MHz}$ $I_C = 1\text{ mA}; V_{CE} = 5\text{ V}$	f_T	min. 100 max. 700	MHz MHz
	C_e	max. 8,0	pF

MECHANICAL DATA

Dimensions in mm

Fig. 1 SOT-23.

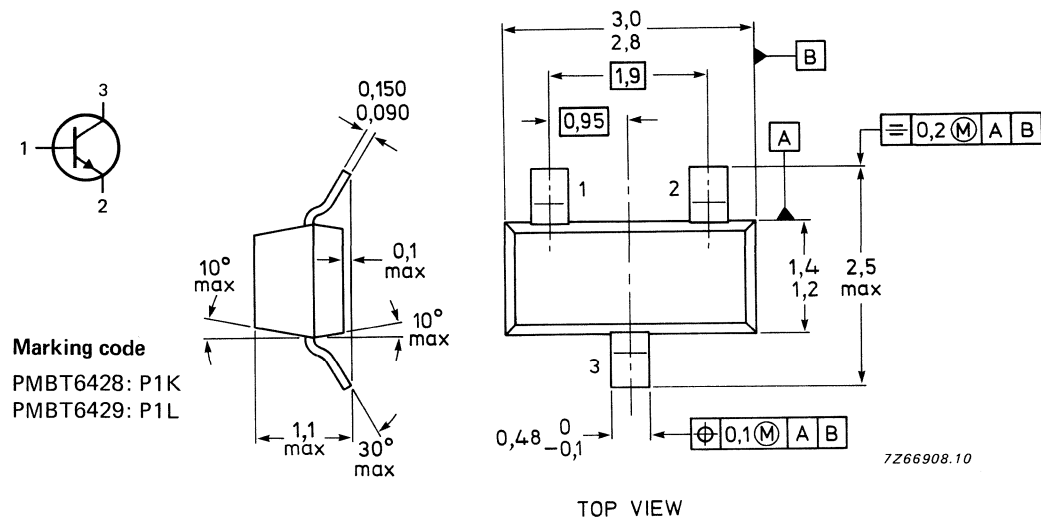

See also Soldering recommendations.

RATINGS

Limiting values in accordance with the Absolute Maximum System (IEC 134)

		PMBT6428	PMBT6429
Collector-base voltage (open emitter)	V_{CBO} max.	60	55 V
Collector-emitter voltage (open base)	V_{CEO} max.	50	45 V
Emitter-base voltage (open collector)	V_{EBO} max.	6,0	V
Collector current (d.c.)	I_C max.	200	mA
Total power dissipation* up to $T_{amb} = 25\text{ }^\circ\text{C}$	P_{tot}	350	mW
Storage temperature	T_{stg}	-55 to +150	$^\circ\text{C}$
Junction temperature	T_j max.	150	$^\circ\text{C}$

THERMAL CHARACTERISTICS

Thermal resistance from junction to ambient*	$R_{th\ j-a}$ =	350	K/W
---	-----------------	-----	-----

CHARACTERISTICS

$T_{amb} = 25\text{ }^\circ\text{C}$ unless otherwise specified

		PMBT6428	PMBT6429
Collector-emitter breakdown voltage $I_C = 1\text{ mA}; I_B = 0$	$V_{(BR)CEO}$ min.	50	45 V
Collector-base breakdown voltage $I_C = 0,1\text{ mA}; I_E = 0$	$V_{(BR)CBO}$ min.	60	55 V
Collector cut-off current $V_{CE} = 30\text{ V}$ $I_E = 0; V_{CB} = 30\text{ V}$	I_{CEO} max. I_{CBO} max.	100 10	nA nA
Emitter cut-off current $I_C = 0; V_{EB} = 5\text{ V}$	I_{EBO} max.	10	nA
Base-emitter On-voltage $I_C = 1\text{ mA}; V_{CE} = 5\text{ V}$	$V_{BE(on)}$ min. max.	560 660	mV mV

* Mounted on a ceramic substrate of 15 mm x 15 mm x 0,7 mm.

		PMBT6428	PMBT6429
Collector-emitter saturation voltage			
$I_C = 10 \text{ mA}; I_B = 0,5 \text{ mA}$	V_{CEsat} max.	0,2	V
$I_C = 100 \text{ mA}; I_B = 5 \text{ mA}$	V_{CEsat} max.	0,6	V
D.C. current gain			
$I_C = 0,1 \text{ mA}; V_{CE} = 5 \text{ V}$	h_{FE} min.	250	500
$I_C = 0,1 \text{ mA}; V_{CE} = 5 \text{ V}$	h_{FE} min.	250	500
	h_{FE} max.	650	1250
$I_C = 1 \text{ mA}; V_{CE} = 5 \text{ V}$	h_{FE} min.	250	500
$I_C = 10 \text{ mA}; V_{CE} = 5 \text{ V}$	h_{FE} min.	250	500
Transition frequency at $f = 100 \text{ MHz}$			
$I_C = 1 \text{ mA}; V_{CE} = 5 \text{ V}$	f_T min.	100	MHz
	f_T max.	700	MHz
Output capacitance at $f = 1 \text{ MHz}$			
$I_F = 0; V_{CB} = 10 \text{ V}$	C_c max.	3,0	pF
Input capacitance at $f = 1 \text{ MHz}$			
$I_C = 0; V_{EB} = 0,5 \text{ V}$	C_e max.	8,0	pF

SILICON EPITAXIAL TRANSISTORS

N-P-N transistors in a microminiature (SMD) plastic envelope intended for surface mounted applications. They are primarily intended for use in telephony and professional communication equipment.

QUICK REFERENCE DATA

		PMBTA05	PMBTA06
Collector-base voltage (open emitter)	V_{CBO}	max. 60	80 V
Collector-emitter voltage (open base)	V_{CEO}	max. 60	80 V
Emitter-base voltage (open collector)	V_{EBO}	max. 4	V
Collector current (d.c.)	I_C	max. 500	mA
Total power dissipation up to $T_{amb} = 25\text{ }^\circ\text{C}$	P_{tot}	max. 300	mW
D.C. current gain	h_{FE}	min. 50	
$I_C = 100\text{ mA}; V_{CE} = 1\text{ V}$			
Transition frequency at $f = 100\text{ MHz}$	f_T	min. 100	MHz
$I_C = 10\text{ mA}; V_{CE} = 2\text{ V}$			
Collector-emitter saturation voltage	V_{CEsat}	max. 0,25	V
$I_C = 100; I_B = 10\text{ mA}$			

MECHANICAL DATA

Fig. 1 SOT-23.

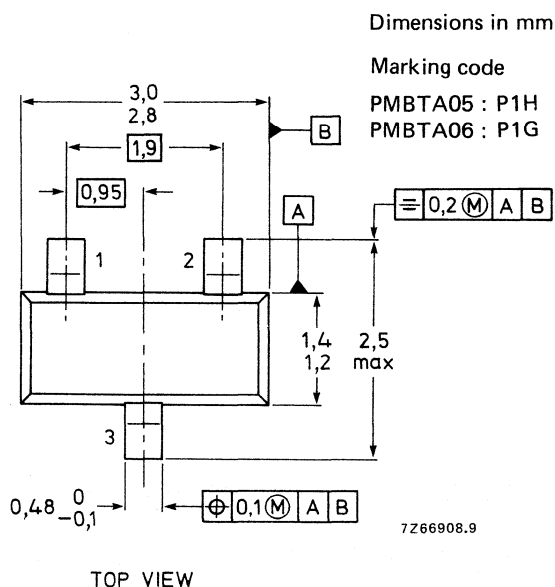
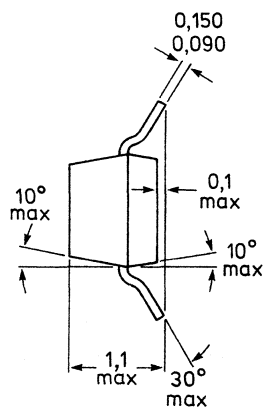
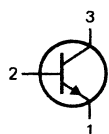

See also Soldering recommendations.

RATINGS

Limiting values in accordance with the Absolute Maximum System (IEC 134)

		PMBTA05	PMBTA06
Collector-base voltage	V_{CBO}	max. 60	80 V
Collector-emitter voltage (open base)	V_{CEO}	max. 60	80 V
Emitter-base voltage (open collector)	V_{EBO}	max. 4	V
Collector current (d.c.)	I_C	max. 500	mA
Total power dissipation * up to $T_{amb} = 25\text{ }^\circ\text{C}$	P_{tot}	max. 300	mW
Storage temperature	T_{stg}	-65 to +150	$^\circ\text{C}$
Junction temperature	T_j	max. 150	$^\circ\text{C}$

THERMAL CHARACTERISTICS **

$$T_j = P (R_{th\ j-t} + R_{th\ t-s} + R_{th\ s-a}) + T_{amb}$$

Thermal resistance

from junction to ambient

$R_{th\ j-a}$	=	430	K/W
---------------	---	-----	-----

CHARACTERISTICS

$T_{amb} = 25\text{ }^\circ\text{C}$ unless otherwise specified

		PMBTA05	PMBTA06
Collector-emitter breakdown voltage ▲ $I_C = 1\text{ mA}; I_B = 0$	$V_{(BR)CEO}$	min. 60	80 V
Emitter-base breakdown voltage $I_C = 0; I_E = 100\text{ }\mu\text{A}$	$V_{(BR)EBO}$	min. 4	V
Collector cut-off current $V_{CE} = 60\text{ V}; I_B = 0$	I_{CEO}	max. 0,1	μA
Collector cut-off current $V_{CB} = 60\text{ V}; I_E = 0$ $V_{CB} = 80\text{ V}; I_E = 0$	I_{CBO}	max. 0,1 max. 0,1	μA μA
Saturation voltages $I_C = 100\text{ mA}; I_B = 10\text{ mA}$	V_{CEsat}	max. 0,25	V
Base-emitter on voltage $I_C = 100\text{ mA}; V_{CE} = 1\text{ V}$	$V_{BE(on)}$	max. 1,2	V
D.C. current gain $I_C = 10\text{ mA}; V_{CE} = 1\text{ V}$	h_{FE}	min. 50	
$I_C = 100\text{ mA}; V_{CE} = 1\text{ V}$	h_{FE}	min. 50	
Transition frequency at $f = 100\text{ MHz}$ $I_C = 10\text{ mA}; V_{CE} = 2\text{ V}$	f_T	min. 100	MHz

* Mounted on a ceramic substrate: area = 10 x 8 mm; thickness = 0,7 mm.

** See Thermal characteristics.

▲ Pulse test conditions: $t_p = 300\text{ }\mu\text{s}$; duty cycle $\leq 2\%$.

N-P-N SMALL-SIGNAL DARLINGTON TRANSISTORS

N-P-N small-signal darlington transistors in a microminiature SMD envelope (SOT-23).
Designed primarily for preamplifier input applications requiring high input impedance.
P-N-P complement is the PMBTA63/64.

QUICK REFERENCE DATA

Collector-emitter voltage $V_{BE} = 0$	V_{CES}	max.	30 V
Collector current (d.c.)	I_C	max.	300 mA
Total power dissipation up to $T_{amb} = 25\text{ }^\circ\text{C}$	P_{tot}	max.	300 mW
Junction temperature	T_j	max.	150 $^\circ\text{C}$
D.C. current gain $I_C = 10\text{ mA}; V_{CE} = 5\text{ V}$	PMBTA13 PMBTA14	h_{FE}	min. 5000 min. 10 000
Transition frequency at $f = 100\text{ MHz}$ $I_C = 10\text{ mA}; V_{CE} = 5\text{ V}$		f_T	min. 125 MHz

MECHANICAL DATA

Dimensions in mm

Fig. 1 SOT-23.

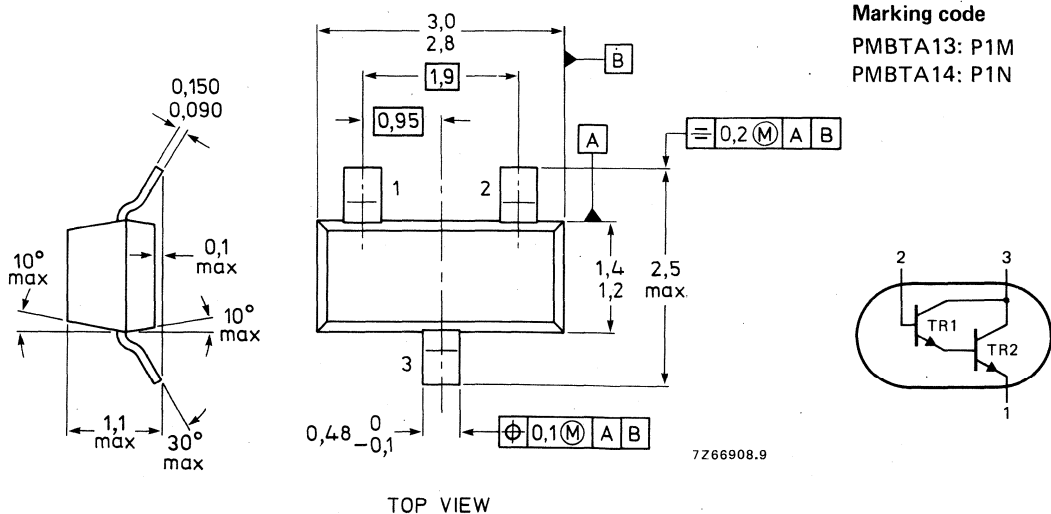

Marking code

PMBTA13: P1M

PMBTA14: P1N

See also Soldering recommendations.

RATINGS

Limiting values in accordance with the Absolute Maximum System (IEC 134)

Collector-base voltage (open emitter)	V_{CBO}	max.	30 V
Collector-emitter voltage $V_{BE} = 0$	V_{CES}	max.	30 V
Emitter-base voltage (open collector)	V_{EBO}	max.	10 V
Collector current (d.c.)	I_C	max.	300 mA
Total power dissipation up to $T_{amb} = 25\text{ }^\circ\text{C}^*$	P_{tot}	max.	300 mW
Storage temperature	T_{stg}		-65 to +150 $^\circ\text{C}$
Junction temperature	T_j	max.	150 $^\circ\text{C}$

THERMAL RESISTANCE

From junction to ambient*	$R_{th\ j-a}$		430 K/W
---------------------------	---------------	--	---------

CHARACTERISTICS

$T_j = 25\text{ }^\circ\text{C}$ unless otherwise specified

Collector-emitter breakdown voltage $I_C = 100\text{ }\mu\text{A}$	$V_{(BR)CES}$	min.	30 V
Emitter-base cut-off current $V_{BE} = 10\text{ V}$	I_{EBO}	max.	0,1 μA
Collector-base cut-off current $V_{CB} = 30\text{ V}$	I_{CBO}	max.	0,1 μA
D.C. current gain $I_C = 10\text{ mA}; V_{CE} = 5\text{ V}$	PMBTA13	h_{FE}	min. 5000
	PMBTA14	h_{FE}	min. 10 000
$I_C = 100\text{ mA}; V_{CE} = 5\text{ V}$	PMBTA13	h_{FE}	min. 10 000
	PMBTA14	h_{FE}	min. 20 000
Collector-emitter saturation voltage $I_C = 100\text{ mA}; I_B = 0,1\text{ mA}$	V_{CEsat}	max.	1,5 V
Base-emitter ON-voltage $I_C = 100\text{ mA}; V_{CE} = 5\text{ V}$	$V_{BE(on)}$	max.	2,0 V
Transition frequency at $f = 100\text{ MHz}$ $I_C = 10\text{ mA}; V_{CE} = 5\text{ V}$	f_T	min.	125 MHz

* Mounted on a ceramic substrate of 8 mm x 10 mm x 0,7 mm.

SILICON EPITAXIAL TRANSISTORS

N-P-N transistors in a microminiature (SMD) plastic envelope intended for surface mounted applications. They are primarily intended for use in telephony and professional communication equipment.

QUICK REFERENCE DATA

		PMBTA42		PMBTA43	
Collector-base voltage (open emitter)	V_{CBO}	max.	300	200	V
Collector-emitter voltage (open base)	V_{CEO}	max.	300	200	V
Emitter-base voltage (open collector)	V_{EBO}	max.		6	V
Collector current (d.c.)	I_C	max.	500		mA
Total power dissipation up to $T_{amb} = 35^\circ\text{C}$	P_{tot}	max.	310		mW
Junction temperature	T_j	max.	150		$^\circ\text{C}$
D.C. current gain	h_{FE}	>	40		
$I_C = 10\text{ mA}; V_{CE} = 10\text{ V}$					
Transition frequency at $f = 35\text{ MHz}$	f_T	>	50		MHz
$I_C = 10\text{ mA}; V_{CE} = 20\text{ V}$					
Feedback capacitance at $f = 1\text{ MHz}$	C_{re}	<	3	4	pF
$I_C = 0; V_{CE} = 20\text{ V}$					

MECHANICAL DATA

Dimensions in mm

Fig. 1 SOT-23.

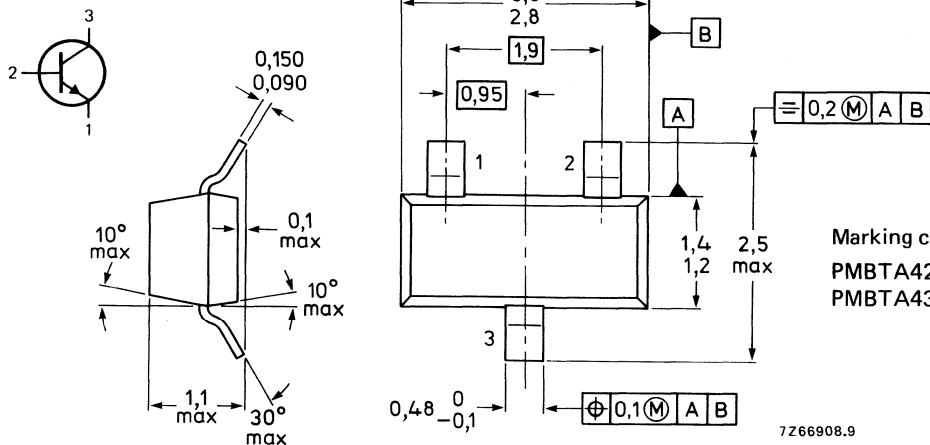

TOP VIEW

See also Soldering recommendations.

RATINGS

Limiting values in accordance with the Absolute Maximum System (IEC 134)

		PMBTA42	PMBTA43
Collector-base voltage (open emitter)	V_{CBO}	max. 300	200 V
Collector-emitter voltage (open base)	V_{CEO}	max. 300	200 V
Emitter-base voltage (open collector)	V_{EBO}	max. 6	V
Collector current (d.c.)	I_C	max. 500	mA
Total power dissipation (note 1) up to $T_{amb} = 35\text{ }^{\circ}\text{C}$	P_{tot}	max. 310	mW
Storage temperature	T_{stg}	-65 to +150	$^{\circ}\text{C}$
Junction temperature	T_j	max. 150	$^{\circ}\text{C}$

THERMAL CHARACTERISTICS (note 2)

$$T_j = P (R_{th\ j-t} + R_{th\ t-s} + R_{th\ s-a}) + T_{amb}$$

Thermal resistance

from junction to ambient

$R_{th\ j-a}$	=	430	K/W
---------------	---	-----	-----

CHARACTERISTICS

$T_{amb} = 25\text{ }^{\circ}\text{C}$ unless otherwise specified

		PMBTA42	PMBTA43
Collector-emitter breakdown voltage (note 3) $I_C = 1\text{ mA}; I_B = 0$	$V_{(BR)CEO} >$	300	200 V
Collector-base breakdown voltage $I_C = 100\text{ }\mu\text{A}; I_E = 0$	$V_{(BR)CBO} >$	300	200 V
Emitter-base breakdown voltage $I_E = 100\text{ }\mu\text{A}; I_C = 0$	$V_{(BR)EBO} >$	6	6 V
Collector cut-off current $I_E = 0; V_{CB} = 200\text{ V}$ $I_E = 0; V_{CB} = 160\text{ V}$	$I_{CBO} <$	0,1 -	- μA 0,1 μA
Emitter cut-off current $I_C = 0; V_{BE} = 6\text{ V}$ $I_C = 0; V_{BE} = 4\text{ V}$	$I_{EBO} <$	0,1 -	- μA 0,1 μA
Feedback capacitance at $f = 1\text{ MHz}$ $I_E = 0; V_{CB} = 20\text{ V}$	$C_{re} <$	3	4 pF

Notes

1. Mounted on a ceramic substrate: area = 2,5 cm²; thickness 0,7 mm.
2. See Thermal characteristics.
3. Pulse test conditions: $t_p = 300\text{ }\mu\text{s}; \delta = 0,02$.

Saturation voltages

$I_C = 20 \text{ mA}; I_B = 2 \text{ mA}$

V_{CEsat}	<	0,5	V
V_{BEsat}	<	0,9	V

D.C. current gain

$I_C = 1 \text{ mA}; V_{CE} = 10 \text{ V}$

$I_C = 10 \text{ mA}; V_{CE} = 10 \text{ V}$

$I_C = 30 \text{ mA}; V_{CE} = 10 \text{ V}$

h_{FE}	>	25	
h_{FE}	>	40	
h_{FE}	>	40	

Transition frequency at $f = 100 \text{ MHz}$

$I_C = 10 \text{ mA}; V_{CE} = 20 \text{ V}$

f_T	>	50	MHz
-------	---	----	-----

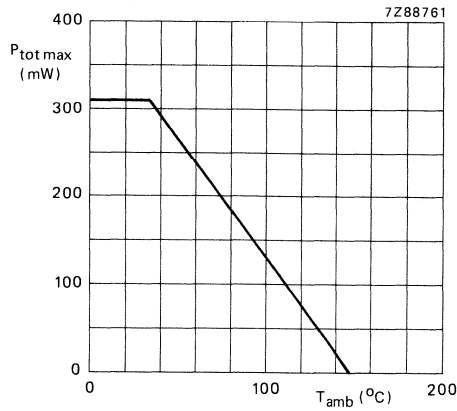

Fig. 2 Power derating curve.

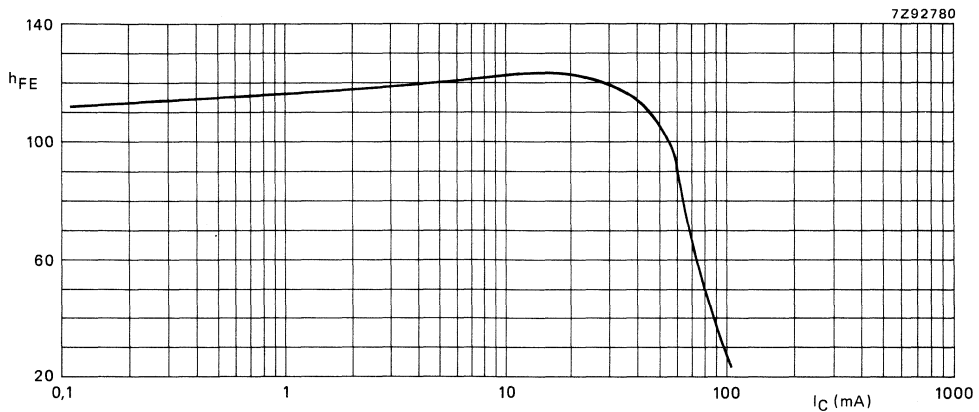

Fig. 3 $T_j = 25 \text{ }^\circ\text{C}; V_{CE} = 20 \text{ V};$ typical values.

SILICON EPITAXIAL TRANSISTORS

P-N-P transistors in a microminiature (SMD) plastic envelope intended for surface mounted applications. They are primarily intended for use in telephony and professional communication equipment.

QUICK REFERENCE DATA

		PMBTA55	PMBTA56
Collector-base voltage (open emitter)	$-V_{CBO}$	max. 60	80 V
Collector-emitter voltage (open base)	$-V_{CEO}$	max. 60	80 V
Emitter-base voltage (open collector)	$-V_{EBO}$	max. 4	V
Collector current (d.c.)	$-I_C$	max. 500	mA
Total power dissipation up to $T_{amb} = 25\text{ }^\circ\text{C}$	P_{tot}	max. 300	mW
D.C. current gain	h_{FE}	min. 50	
Transition frequency at $f = 100\text{ MHz}$	f_T	min. 50	MHz
Collector-emitter saturation voltage	V_{CEsat}	max. 0,25	V

MECHANICAL DATA

Fig. 1 SOT-23.

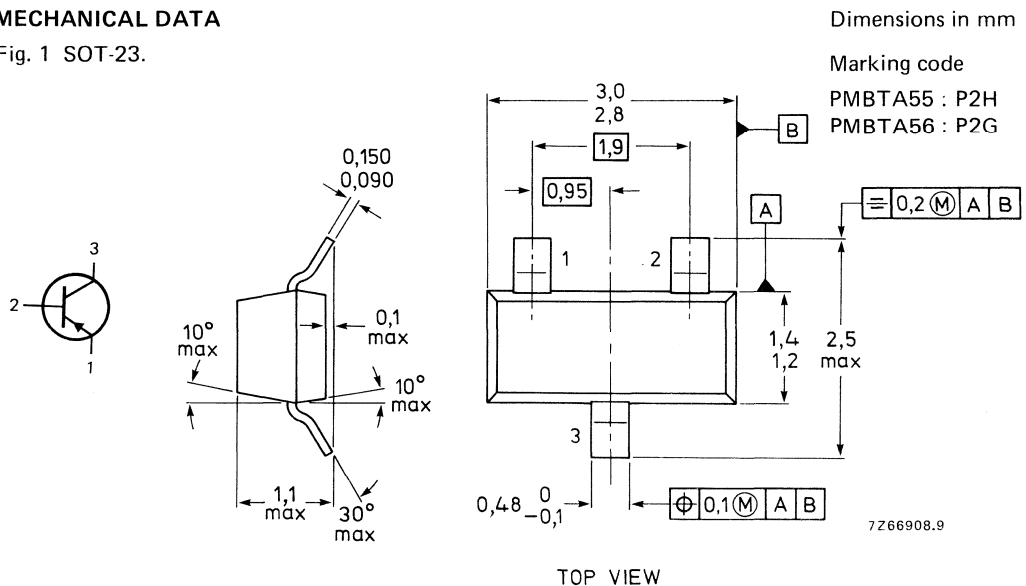

See also Soldering recommendations.

RATINGS

Limiting values in accordance with the Absolute Maximum System (IEC 134)

		PMBTA55	PMBTA56
Collector-base voltage (open emitter)	$-V_{CB0}$	max. 60	80 V
Collector-emitter voltage (open base)	$-V_{CEO}$	max. 60	80 V
Emitter-base voltage (open collector)	$-V_{EBO}$	max. 4	V
Collector current (d.c.)	$-I_C$	max. 500	mA
Total power dissipation * up to $T_{amb} = 25\text{ }^{\circ}\text{C}$	P_{tot}	max. 300	mW
Storage temperature	T_{stg}	-65 to +150	$^{\circ}\text{C}$
Junction temperature	T_j	max. 150	$^{\circ}\text{C}$

THERMAL CHARACTERISTICS**

$$T_j = P (R_{th\ j-t} + R_{th\ t-s} + R_{th\ s-a}) + T_{amb}$$

Thermal resistance

from junction to ambient

$$R_{th\ j-a} = 430 \text{ K/W}$$

CHARACTERISTICS

$T_{amb} = 25\text{ }^{\circ}\text{C}$ unless otherwise specified

		PMBTA55	PMBTA56
Collector-emitter breakdown voltage Δ $-I_C = 1\text{ mA}; I_B = 0$	$-V_{(BR)CEO}$	min. 60	80 V
Emitter-base breakdown voltage $-I_C = 0; I_E = 100\text{ }\mu\text{A}$	$-V_{(BR)EBO}$	min. 4	V
Collector cut-off current $-V_{CE} = 60\text{ V}; I_B = 0$	$-I_{CEO}$	max. 0,1	μA
Collector cut-off current $-V_{CB} = 60\text{ V}; I_E = 0$ $-V_{CB} = 80\text{ V}; I_E = 0$	$-I_{CBO}$	max. 0,1 max. 0,1	μA μA
Saturation voltages $-I_C = 100\text{ mA}; -I_B = 10\text{ mA}$	$-V_{CEsat}$	max. 0,25	V
Base-emitter on voltage $-I_C = 100\text{ mA}; -V_{CE} = 1\text{ V}$	$-V_{BE(on)}$	max. 1,2	V
D.C. current gain $-I_C = 10\text{ mA}; -V_{CE} = 1\text{ V}$	h_{FE}	min. 50	
$-I_C = 100\text{ mA}; -V_{CE} = 1\text{ V}$	h_{FE}	min. 50	
Transition frequency at $f = 100\text{ MHz}$ $-I_C = 100\text{ mA}; -V_{CE} = 1\text{ V}$	f_T	min. 50	MHz

* Mounted on a ceramic substrate: area = 10 x 8 mm; thickness = 0,7 mm.

** See Thermal characteristics.

Δ Pulse test conditions: $t_p = 300\text{ }\mu\text{s}$; duty cycle $\leq 2\%$.

P-N-P SMALL-SIGNAL DARLINGTON TRANSISTORS

P-N-P small-signal darlington transistors in a microminiature SMD envelope (SOT-23).
Designed primarily for preamplifier input applications requiring high input impedance.
N-P-N complement is the PMBTA13/14.

QUICK REFERENCE DATA

Collector-emitter voltage $V_{BE} = 0$	$-V_{CES}$	max.	30 V
Collector current (d.c.)	$-I_C$	max.	500 mA
Total power dissipation up to $T_{amb} = 25\text{ }^\circ\text{C}$	P_{tot}	max.	300 mW
Junction temperature	T_j	max.	150 $^\circ\text{C}$
D.C. current gain			
$-I_C = 10\text{ mA}; -V_{CE} = 5\text{ V}$	PMBTA63	h_{FE}	min. 5000
	PMBTA64	h_{FE}	min. 10 000
Transition frequency at $f = 100\text{ MHz}$			
$-I_C = 10\text{ mA}; -V_{CE} = 50\text{ V}$		f_T	min. 125 MHz

MECHANICAL DATA

Fig. 1 SOT-23.

Dimensions in mm

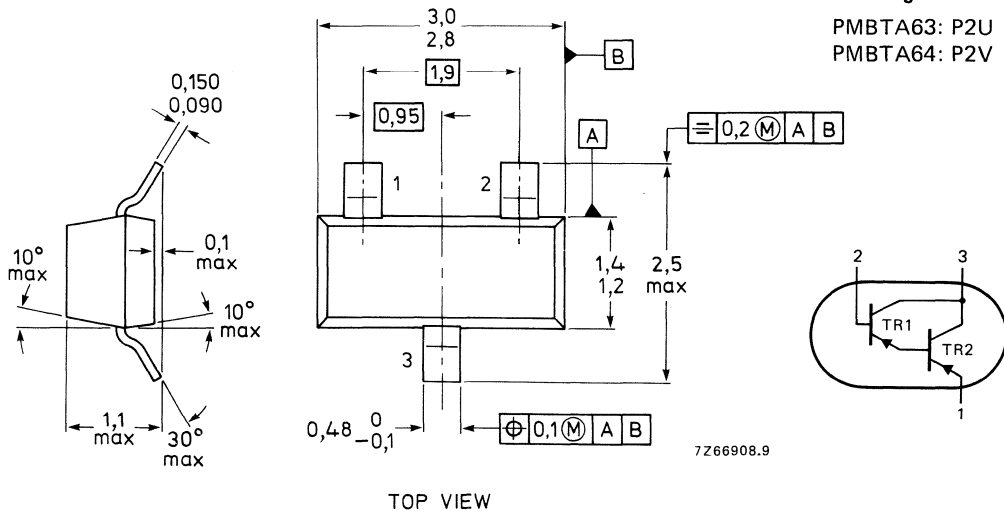

Marking code

PMBTA63: P2U
PMBTA64: P2V

See also Soldering recommendations.

RATINGS

Limiting values in accordance with the Absolute Maximum System (IEC 134)

Collector-base voltage (open emitter)	$-V_{CBO}$	max.	30 V
Collector-emitter voltage $V_{BE} = 0$	$-V_{CES}$	max.	30 V
Emitter-base voltage (open collector)	$-V_{EBO}$	max.	10 V
Collector current (d.c.)	$-I_C$	max.	500 mA
Total power dissipation up to $T_{amb} = 25\text{ }^\circ\text{C}^*$	P_{tot}	max.	500 mW
Storage temperature	T_{stg}		-65 to +150 $^\circ\text{C}$
Junction temperature	T_j	max.	150 $^\circ\text{C}$

THERMAL RESISTANCE

From junction to ambient*	$R_{th\ j-a}$		430 K/W
---------------------------	---------------	--	---------

CHARACTERISTICS

$T_j = 25\text{ }^\circ\text{C}$ unless otherwise specified

Collector-emitter breakdown voltage $-I_C = 100\text{ }\mu\text{A}$	$-V_{(BR)CES}$	min.	30 V
Emitter-base cut-off current $-V_{BE} = 10\text{ V}$	$-I_{EBO}$	max.	0,1 μA
Collector-base cut-off current $-V_{CB} = 30\text{ V}$	$-I_{CBO}$	max.	0,1 μA
D.C. current gain $-I_C = 10\text{ mA}; -V_{CE} = 5\text{ V}$	PMBTA63	h_{FE}	min. 5000
	PMBTA64	h_{FE}	min. 10 000
$-I_C = 100\text{ mA}; -V_{CE} = 5\text{ V}$	PMBTA63	h_{FE}	min. 10 000
	PMBTA64	h_{FE}	min. 20 000
Collector-emitter saturation voltage $-I_C = 100\text{ mA}; -I_B = 0,1\text{ mA}$	$-V_{CEsat}$	max.	1,5 V
Base-emitter ON-voltage $-I_C = 100\text{ mA}; -V_{CE} = 5\text{ V}$	$-V_{BE(on)}$	max.	2,0 V
Transition frequency at $f = 100\text{ MHz}$ $-I_C = 10\text{ mA}; -V_{CE} = 50\text{ V}; T_{amb} = 25\text{ }^\circ\text{C}$	f_T	min.	125 MHz

* Mounted on a ceramic substrate of 8 mm x 10 mm x 0,7 mm.

RATINGS

Limiting values in accordance with the Absolute Maximum System (IEC 134)

			PMBTA92	PMBTA93
Collector-base voltage (open emitter)	$-V_{CB0}$	max.	300	200 V
Collector-emitter voltage (open base)	$-V_{CEO}$	max.	300	200 V
Emitter-base voltage (open collector)	$-V_{EBO}$	max.	5	V
Collector current (d.c.)	$-I_C$	max.	500	mA
Total power dissipation * up to $T_{amb} = 25\text{ }^\circ\text{C}$	P_{tot}	max.	300	mW
Storage temperature	T_{stg}		-65 to +150	$^\circ\text{C}$
Junction temperature	T_j	max.	150	$^\circ\text{C}$

THERMAL CHARACTERISTICS **

$$T_j = P (R_{th\ j-t} + R_{th\ t-s} + R_{th\ s-a}) + T_{amb}$$

Thermal resistance

from junction to ambient*

$$R_{th\ j-a} = 430\text{ K/W}$$

CHARACTERISTICS

$T_{amb} = 25\text{ }^\circ\text{C}$ unless otherwise specified

			PMBTA92	PMBTA93
Collector-emitter breakdown voltage $-I_C = 1\text{ mA}; I_B = 0$	$-V_{(BR)CEO}$	min.	300	200 V
Collector-base breakdown voltage $-I_C = 100\text{ }\mu\text{A}; I_E = 0$	$-V_{(BR)CBO}$	min.	300	200 V
Collector cut-off current $-V_{CB} = 200\text{ V}; I_E = 0$ $-V_{CB} = 160\text{ V}; I_E = 0$	$-I_{CBO}$	max. max.	0,25 -	- μA 0,25 μA
Emitter-base breakdown voltage $-I_E = 100\text{ }\mu\text{A}; I_C = 0$	$-V_{(BR)EBO}$	min.	5	V
Emitter cut-off current $I_C = 0; -V_{BE} = 3\text{ V}$	$-I_{EBO}$	max.	0,1	μA
Collector-base capacitance at $f = 1\text{ MHz};$ $I_E = 0; -V_{CB} = 20\text{ V}$	C_{cb}	max.	6	8 pF
Saturation voltages $-I_C = 20\text{ mA}; -I_B = 2\text{ mA}$ $-I_C = 20\text{ mA}; -I_B = 2\text{ mA}$	$-V_{CEsat}$ $-V_{BEsat}$	max. max.	0,5 0,9	V V
D.C. current gain \blacktriangle $-I_C = 1\text{ mA}; -V_{CE} = 10\text{ V}$ $-I_C = 10\text{ mA}; -V_{CE} = 10\text{ V}$ $-I_C = 30\text{ mA}; -V_{CE} = 10\text{ V}$	h_{FE}	min. min. min.	25 40 25	

* Mounted on a ceramic substrate: area = 10 x 8 mm; thickness = 0,7 mm.

** See Thermal characteristics.

\blacktriangle Pulse test conditions: $t_p = 300\text{ }\mu\text{s}$; duty cycle $\leq 2\%$.

VOLTAGE REGULATOR DIODES FOR SURFACE MOUNTING

Silicon planar diodes in a SOD-80 envelope intended for use as low-power voltage stabilizers or voltage references.

The series consists of 43 types with nominal working voltages ranging from 3,0 V to 75 V.

The SM diode is a leadless diode in a hermetically sealed glass SOD-80 envelope with tin-plated metal discs at each end. It is suitable for "automatic placement" and as such can withstand immersion soldering.

The diodes are delivered on "super 8" tape.

QUICK REFERENCE DATA

Working voltage range	V_Z	nom.	3,0 to 75 V
Working voltage tolerance			$\pm 5 \%$
Total power dissipation	P_{tot}	max.	500 mW
Non-repetitive peak reverse power dissipation $T_j = 55 \text{ }^\circ\text{C}; t_p = 8,3 \text{ ms, square wave}$	P_{ZSM}	max.	10 W
Junction temperature	T_j		$-65 \text{ to } +200 \text{ }^\circ\text{C}$

MECHANICAL DATA

Dimensions in mm

Fig. 1 SOD-80.

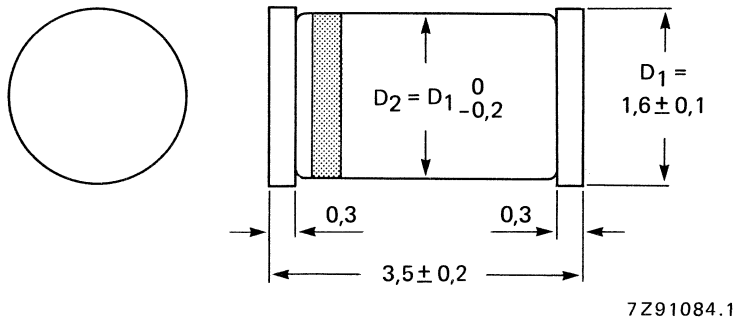

Cathode indicated by yellow band.

RATINGS

Limiting values in accordance with the Absolute Maximum System (IEC 134)

Average forward current (averaged over any 20 ms period)	$I_F(AV)$	max.	250 mA
Repetitive peak forward current	I_{FRM}	max.	250 mA
Total power dissipation if flanges are kept at $T_{flange} = 75\text{ }^\circ\text{C}$	P_{tot}	max.	500 mW
Derating factor			4 mW/K
Non-repetitive peak reverse power dissipation $T_j = 55\text{ }^\circ\text{C}$; $t_p = 8,3\text{ ms}$, square wave	P_{ZSM}	max.	10 W
Storage temperature	T_{stg}		-65 to +200 $^\circ\text{C}$
Junction temperature	T_j		-65 to +200 $^\circ\text{C}$

CHARACTERISTICS

$T_{amb} = 25\text{ }^\circ\text{C}$ unless otherwise stated

Forward voltage

$I_F = 200\text{ mA}$

V_F max. 1,1 V

type number	working voltage V_Z (V) at I_{Ztest} (note 1) nom.	test current I_{Ztest} (mA)	max. Zener impedance Z_{ZT} (Ω) at I_{Ztest} (note 2)	differential resistance r_{diff} (Ω) at $I_{ZK} = 0,25\text{ mA}$ (note 2) max.	reverse current I_R (μA) at V_R max.	test voltage V_R (V)	temp. coeff. S_Z (%/K) (note 3) max.
PMLL5225B	3,0	20	29	1600	50	1,0	-0,075
PMLL5226B	3,3	20	28	1600	25	1,0	-0,070
PMLL5227B	3,6	20	24	1700	15	1,0	-0,065
PMLL5228B	3,9	20	23	1900	10	1,0	-0,060
PMLL5229B	4,3	20	22	2000	5	1,0	$\pm 0,055$
PMLL5230B	4,7	20	19	1900	5	2,0	$\pm 0,030$
PMLL5231B	5,1	20	17	1600	5	2,0	$\pm 0,030$
PMLL5232B	5,6	20	11	1600	5	3,0	+0,038
PMLL5233B	6,0	20	7	1600	5	3,5	+0,038
PMLL5234B	6,2	20	7	1000	5	4,0	+0,045
PMLL5235B	6,8	20	5	750	3	5,0	+0,050
PMLL5236B	7,5	20	6	500	3	6,0	+0,058
PMLL5237B	8,2	20	8	500	3	6,5	+0,062
PMLL5238B	8,7	20	8	600	3	6,5	+0,065
PMLL5239B	9,1	20	10	600	3	7,0	+0,068

type number	working voltage V_Z (V) at I_{Ztest} (note 1) nom.	test current I_{Ztest} (mA)	max. Zener impedance Z_{ZT} (Ω) at I_{Ztest} (note 2)	differential resistance r_{diff} (Ω) at $I_{ZK} = 0,25 \text{ mA}$ (note 2) max.	reverse current I_R (μA) at V_R max.	test voltage V_R (V)	temp. coeff. S_Z (%/K) ← (note 3) max.
PMLL5240B	10	20	17	600	3	8,0	+ 0,075
PMLL5241B	11	20	22	600	2	8,4	+ 0,076
PMLL5242B	12	20	30	600	1	9,1	+ 0,077
PMLL5243B	13	9,5	13	600	0,5	9,9	+ 0,079
PMLL5244B	14	9,0	15	600	0,1	10	+ 0,082
PMLL5245B	15	8,5	16	600	0,1	11	+ 0,082
PMLL5246B	16	7,8	17	600	0,1	12	+ 0,083
PMLL5247B	17	7,4	19	600	0,1	13	+ 0,084
PMLL5248B	18	7,0	21	600	0,1	14	+ 0,085
PMLL5249B	19	6,6	23	600	0,1	14	+ 0,086
PMLL5250B	20	6,2	25	600	0,1	15	+ 0,086
PMLL5251B	22	5,6	29	600	0,1	17	+ 0,087
PMLL5252B	24	5,2	33	600	0,1	18	+ 0,088
PMLL5253B	25	5,0	35	600	0,1	19	+ 0,089
PMLL5254B	27	4,6	41	600	0,1	21	+ 0,090
PMLL5255B	28	4,5	44	600	0,1	21	+ 0,091
PMLL5256B	30	4,2	49	600	0,1	23	+ 0,091
PMLL5257B	33	3,8	58	700	0,1	25	+ 0,092
PMLL5258B	36	3,4	70	700	0,1	27	+ 0,093
PMLL5259B	39	3,2	80	800	0,1	30	+ 0,094
PMLL5260B	43	3,0	93	900	0,1	33	+ 0,095
PMLL5261B	47	2,7	105	1000	0,1	36	+ 0,095
PMLL5262B	51	2,5	125	1100	0,1	39	+ 0,096
PMLL5263B	56	2,2	150	1300	0,1	43	+ 0,096
PMLL5264B	60	2,1	170	1400	0,1	46	+ 0,097
PMLL5265B	62	2,0	185	1400	0,1	47	+ 0,097
PMLL5266B	68	1,8	230	1600	0,1	52	+ 0,097
PMLL5267B	75	1,7	270	1700	0,1	56	+ 0,098

Notes

- V_Z is measured with device at thermal equilibrium while held in clips in still air at 25 °C.
- $I_{(ac\ rms)}$ = 10% of I_{Ztest} resp. I_{ZK} , 60 Hz superimposed.
- For types PMLL5225B to PMLL5242B the current $I_Z = 7,5 \text{ mA}$; for PMLL5243B and higher $I_Z = I_{Ztest}$. Testpoints at $T_1 = 25 \text{ °C}$, $T_2 = 125 \text{ °C}$.

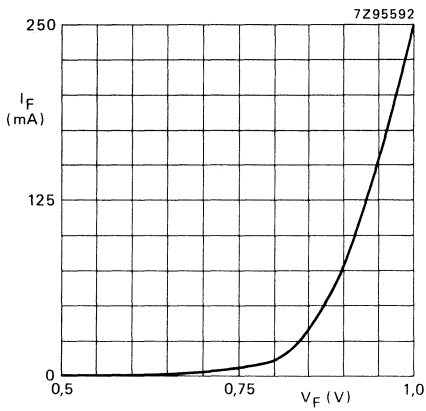

Fig. 2 $T_{amb} = 25\text{ }^{\circ}\text{C}$; typical values.

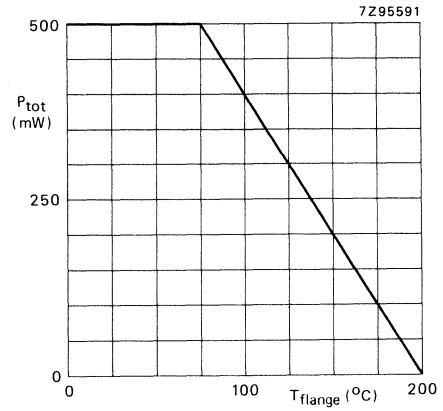

Fig. 3 Total power dissipation versus flange temperature.

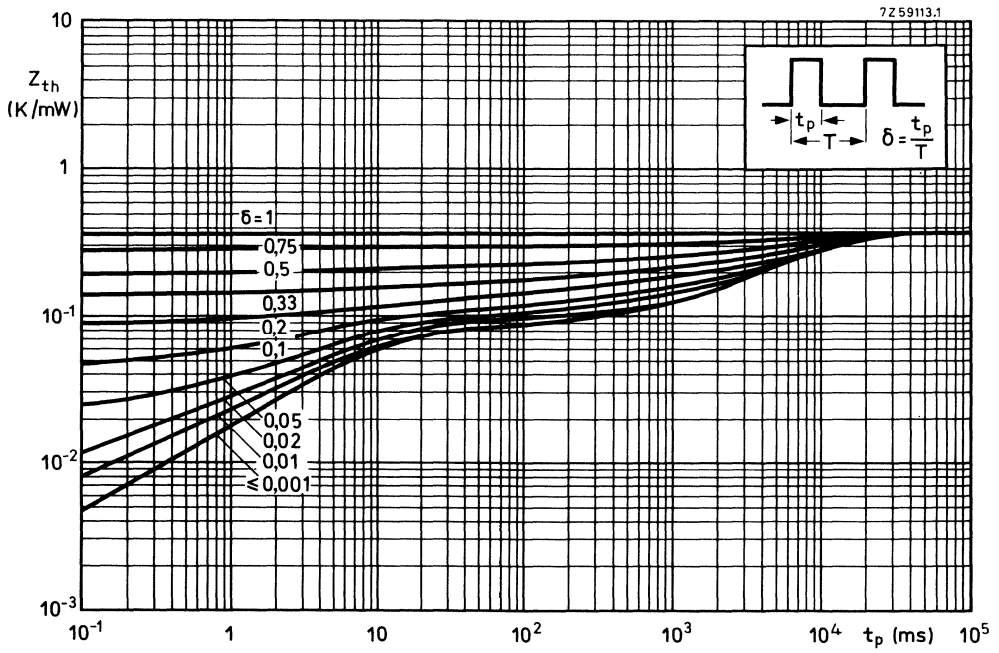

Fig. 4 Thermal impedance versus pulse duration.

SILICON PLANAR EPITAXIAL TRANSISTOR

N-P-N transistor in a SOT-89 envelope primarily intended for high-speed, saturated switching applications for industrial service.

QUICK REFERENCE DATA

Collector-base voltage (open emitter)	V_{CBO}	max.	60 V
Collector-emitter voltage (open base)	V_{CEO}	max.	40 V
Collector current (d.c.)	I_C	max.	200 mA
Total power dissipation at $T_{amb} = 25\text{ }^\circ\text{C}$	P_{tot}	max.	1,0 W
Junction temperature	T_j	max.	150 $^\circ\text{C}$
D.C. current gain	h_{FE}	>	100
$I_C = 10\text{ mA}; V_{CE} = 1\text{ V}$		<	300
Transition frequency at $f = 100\text{ MHz}$	f_T	>	300 MHz
$I_C = 10\text{ mA}; V_{CE} = 20\text{ V}$			
Storage time	t_s	<	200 ns
$I_{Con} = 10\text{ mA}; I_{Bon} = -I_{Boff} = 1\text{ mA}$			

MECHANICAL DATA

Fig. 1 SOT-89.

Dimensions in mm

Marking code

P1A

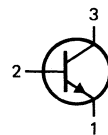
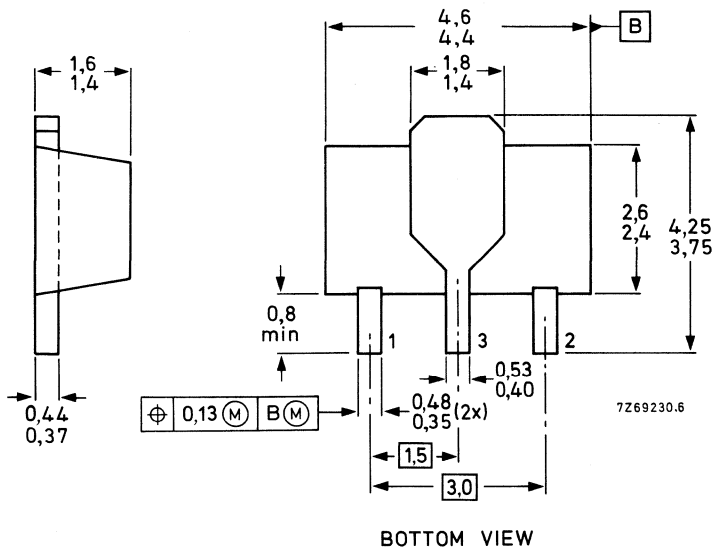

RATINGS

Limiting values in accordance with the Absolute Maximum System (IEC 134)

Collector-base voltage (open emitter)	V_{CBO}	max.	60 V
Collector-emitter voltage (open base)	V_{CEO}	max.	40 V
Emitter-base voltage (open collector)	V_{EBO}	max.	6 V
Collector current (d.c.)	I_C	max.	200 mA
Total power dissipation at $T_{amb} = 25\text{ }^\circ\text{C}^*$	P_{tot}	max.	1,0 W
Storage temperature	T_{stg}		-55 to +150 $^\circ\text{C}$
Junction temperature	T_j	max.	150 $^\circ\text{C}$

THERMAL RESISTANCE

From junction to ambient in free air	$R_{th\ j-a}$	=	125 K/W
--------------------------------------	---------------	---	---------

CHARACTERISTICS

$T_j = 25\text{ }^\circ\text{C}$ unless otherwise specified

Currents at reverse biased emitter junction

$V_{CE} = 30\text{ V}; -V_{BE} = 3\text{ V}$	I_{CEX}	<	50 nA
	$-I_{BEX}$	<	50 nA

Saturation voltages

$I_C = 10\text{ mA}; I_B = 1\text{ mA}$	V_{CEsat}	<	200 mV
	V_{BEsat}		650 to 850 mV

$I_C = 50\text{ mA}; I_B = 5\text{ mA}$	V_{CEsat}	<	300 mV
	V_{BEsat}	<	950 mV

D.C. current gain

$I_C = 0,1\text{ mA}; V_{CE} = 1\text{ V}$	h_{FE}	>	40
--	----------	---	----

$I_C = 1\text{ mA}; V_{CE} = 1\text{ V}$	h_{FE}	>	70
--	----------	---	----

$I_C = 10\text{ mA}; V_{CE} = 1\text{ V}$	h_{FE}	>	100
---	----------	---	-----

$I_C = 50\text{ mA}; V_{CE} = 1\text{ V}$	h_{FE}	>	300
---	----------	---	-----

$I_C = 100\text{ mA}; V_{CE} = 1\text{ V}$	h_{FE}	>	60
--	----------	---	----

Collector capacitance at $100\text{ kHz} \leq f \leq 1\text{ MHz}$

$I_E = I_e = 0; V_{CB} = 5\text{ V}$	C_c	<	4,0 pF
--------------------------------------	-------	---	--------

Emitter capacitance at $100\text{ kHz} \leq f \leq 1\text{ MHz}$

$I_C = I_c = 0; V_{EB} = 0,5\text{ V}$	C_e	<	8,0 pF
--	-------	---	--------

Transition frequency at $f = 100\text{ MHz}$

$I_C = 10\text{ mA}; V_{CE} = 20\text{ V}; T_{amb} = 25\text{ }^\circ\text{C}$	f_T	>	300 MHz
--	-------	---	---------

Noise figure at $R_S = 1\text{ k}\Omega$

$I_C = 100\text{ }\mu\text{A}; V_{CE} = 5\text{ V}$			
$f = 10\text{ Hz to } 15,7\text{ kHz}; T_{amb} = 25\text{ }^\circ\text{C}$	F	<	5,0 dB

* $R_{th\ j-a}$ is based on a ceramic substrate area = 2,5 cm²; thickness = 0,7 mm.

h-parameters (common emitter)

$I_C = 1 \text{ mA}; V_{CE} = 10 \text{ V}; f = 1 \text{ kHz}; T_{\text{amb}} = 25 \text{ }^\circ\text{C}$

Input impedance

Reverse voltage transfer ratio

Small-signal current gain

Output admittance

h_{ie}	1 to 10 $k\Omega$
h_{re}	0,5 to 8×10^{-4}
h_{fe}	100 to 400
h_{oe}	1 to 40 μS

Switching times

Turn-on time (see Figs 2 and 3) when switched from

$-V_{BE\text{off}} = 0,5 \text{ V}$ to $I_{Con} = 10 \text{ mA}; I_{Bon} = 1 \text{ mA}$

Delay time

Rise time

t_d	<	35 ns
t_r	<	35 ns

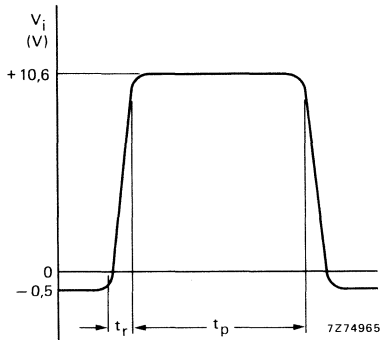

Fig. 2 Input waveform; $t_r < 1 \text{ ns}; t_p = 300 \text{ ns}; \delta = 0,02$.

Turn-off time (see Figs 4 and 5)

$I_{Con} = 10 \text{ mA}; I_{Bon} = -I_{Boff} = 1 \text{ mA}$

Storage time

Fall time

t_s	<	200 ns
t_f	<	50 ns

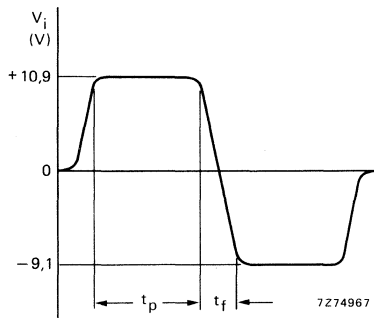

Fig. 4 Input waveform; $t_f < 1 \text{ ns}; 10 \mu s < t_p < 500 \mu s; \delta = 0,02$.

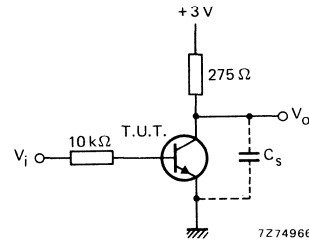

Fig. 3 Delay and rise time test circuit; total shunt capacitance of test jig and connectors $C_s < 4 \text{ pF}$; scope impedance = $10 \text{ M}\Omega$.

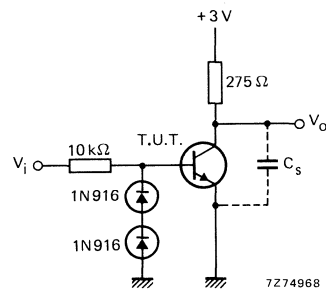

Fig. 5 Storage and fall time test circuit; total shunt capacitance of test jig and connectors $C_s < 4 \text{ pF}$; scope impedance = $10 \text{ M}\Omega$.

RATINGS

Limiting values in accordance with the Absolute Maximum System (IEC 134)

Collector-base voltage (open emitter)	$-V_{CB0}$	max.	40 V
Collector-emitter voltage (open base)	$-V_{CE0}$	max.	40 V
Emitter-base voltage (open collector)	$-V_{EB0}$	max.	5 V
Collector current (d.c.)	$-I_C$	max.	200 mA
Total power dissipation at $T_{amb} = 25\text{ }^\circ\text{C}^*$	P_{tot}	max.	1,0 W
Storage temperature	T_{stg}		-55 to +150 $^\circ\text{C}$
Junction temperature	T_j	max.	150 $^\circ\text{C}$

THERMAL RESISTANCE

From junction to ambient in free air*	$R_{th\ j-a}$	=	125 K/W
---------------------------------------	---------------	---	---------

CHARACTERISTICS

$T_j = 25\text{ }^\circ\text{C}$ unless otherwise specified

Currents at reverse biased emitter junction

$-V_{CE} = 30\text{ V}; +V_{BE} = 3\text{ V}$	$-I_{CEX}$	<	50 nA
	$+I_{BEX}$	<	50 nA

Saturation voltages

$-I_C = 10\text{ mA}; -I_B = 1\text{ mA}$	$-V_{CEsat}$	<	250 mV
	$-V_{BEsat}$		650 to 850 mV
$-I_C = 50\text{ mA}; -I_B = 5\text{ mA}$	$-V_{CEsat}$	<	400 mV
	$-V_{BEsat}$	<	950 mV

D.C. current gain

$-I_C = 0,1\text{ mA}; -V_{CE} = 1\text{ V}$	h_{FE}	>	60
$-I_C = 1\text{ mA}; -V_{CE} = 1\text{ V}$	h_{FE}	>	80
$-I_C = 10\text{ mA}; -V_{CE} = 1\text{ V}$	h_{FE}	>	100
$-I_C = 50\text{ mA}; -V_{CE} = 1\text{ V}$	h_{FE}	<	300
$-I_C = 100\text{ mA}; -V_{CE} = 1\text{ V}$	h_{FE}	>	60
	h_{FE}	>	30

Collector capacitance at $100\text{ kHz} \leq f \leq 1\text{ MHz}$

$I_E = I_e = 0; -V_{CB} = 5\text{ V}$	C_c	<	4,5 pF
---------------------------------------	-------	---	--------

Emitter capacitance at $100\text{ kHz} \leq f \leq 1\text{ MHz}$

$I_C = I_c = 0; -V_{EB} = 0,5\text{ V}$	C_e	<	10 pF
---	-------	---	-------

Transition frequency at $f = 100\text{ MHz}$

$-I_C = 10\text{ mA}; -V_{CE} = 20\text{ V}; T_{amb} = 25\text{ }^\circ\text{C}$	f_T	>	250 MHz
--	-------	---	---------

Noise figure at $R_S = 1\text{ k}\Omega$

$-I_C = 100\text{ }\mu\text{A}; -V_{CE} = 5\text{ V}$ $f = 10\text{ Hz to } 15,7\text{ kHz}; T_{amb} = 25\text{ }^\circ\text{C}$	F	<	4,0 dB
---	---	---	--------

* Mounted on a ceramic substrate area = 2,5 cm²; thickness = 0,7 mm.

h-parameters (common emitter)

$-I_C = 1 \text{ mA}; -V_{CE} = 10 \text{ V}; f = 1 \text{ kHz}; T_{\text{amb}} = 25 \text{ }^\circ\text{C}$

Input impedance

h_{ie} 2 to 12 $\text{k}\Omega$

Reverse voltage transfer ratio

h_{re} 0,1 to 10×10^{-4}

Small-signal current gain

h_{fe} 100 to 400

Output admittance

h_{oe} 3 to 60 μS

Switching times

Turn-on time (see Figs 2 and 3) when switched from

$+V_{BE\text{off}} = 0,5 \text{ V}$ to $-I_{C\text{on}} = 10 \text{ mA}; -I_{B\text{on}} = 1 \text{ mA}$

Delay time

t_d < 35 ns

Rise time

t_r < 35 ns

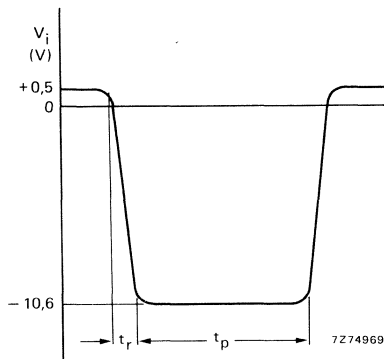

Fig. 2 Input waveform; $t_r < 1 \text{ ns}; t_p = 300 \text{ ns}; \delta = 0,02$.

Turn-off time (see Figs 4 and 5)

$-I_{C\text{on}} = 10 \text{ mA}; -I_{B\text{on}} = I_{B\text{off}} = 1 \text{ mA}$

Storage time

t_s < 225 ns

Fall time

t_f < 75 ns

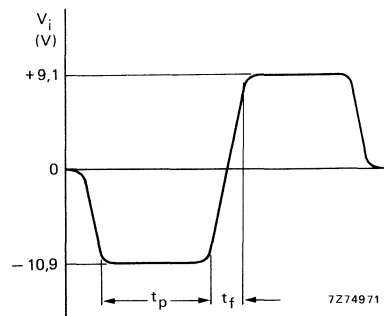

Fig. 4 Input waveform; $t_f < 1 \text{ ns}; 10 \mu\text{s} < t_p < 500 \mu\text{s}; \delta = 0,02$.

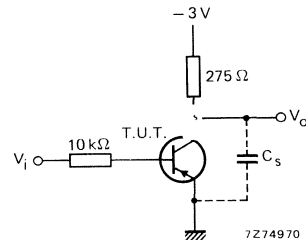

Fig. 3 Delay and rise time test circuit; total shunt capacitance of test jig and connectors $C_s < 4 \text{ pF};$ scope impedance = $10 \text{ M}\Omega$.

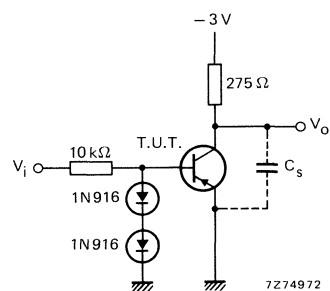
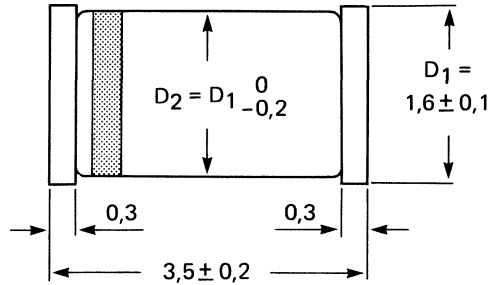
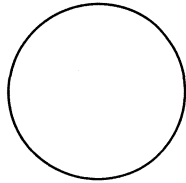

Fig. 5 Storage and fall time test circuit; total shunt capacitance of test jig and connectors $C_s < 4 \text{ pF};$ scope impedance = $10 \text{ M}\Omega$.

MECHANICAL DATA (European projection)

Dimensions in mm

SOD-80



7Z91084.1

SOT-143

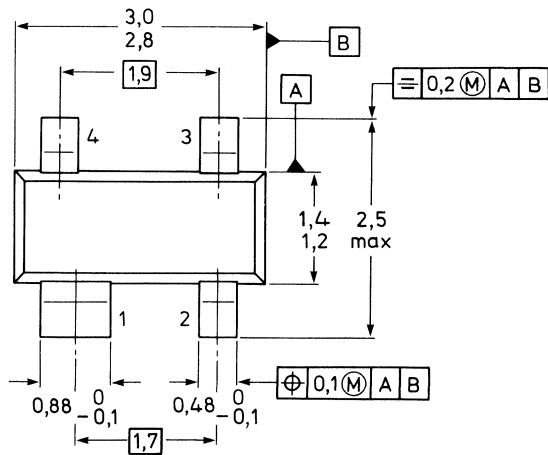
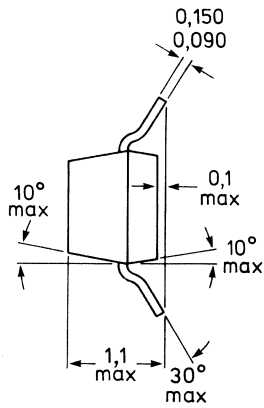

7Z85014.6

TOP VIEW

INDEX OF TYPE NUMBERS

The inclusion of a type number in this publication does not necessarily imply its availability.

type no.	book	section	type no.	book	section	type no.	book	section
BA220	S1	SD	BAS29	S7/S1	Mm/SD	BAV99	S7/S1	Mm/SD
BA221	S1	SD	BAS31	S7/S1	Mm/SD	BAV100	S7/S1	Mm/SD
BA223	S1	T	BAS32	S7/S1	Mm/SD	BAV101	S7/S1	Mm/SD
BA281	S1	SD	BAS35	S7/S1	Mm/SD	BAV102	S7/S1	Mm/SD
BA314	S1	Vrg	BAS45	S1	SD	BAV103	S7/S1	Mm/SD
BA315	S1	Vrg	BAS56	S1/S7	SD/Mm	BAW56	S7/S1	Mm/SD
BA316	S1	SD	BAT17	S7/S1	Mm/T	BAW62	S1	SD
BA317	S1	SD	BAT18	S7/S1	Mm/T	BAX12	S1	SD
BA318	S1	SD	BAT54	S1/S7	SD/Mm	BAX14	S1	SD
BA423	S1	T	BAT74	S1/S7	SD/Mm	BAX18	S1	SD
BA480	S1	T	BAT81	S1	T	BAY80	S1	SD
BA481	S1	T	BAT82	S1	T	BB112	S1	T
BA482	S1	T	BAT83	S1	T	BB119	S1	T
BA483	S1	T	BAT85	S1	T	BB130	S1	T
BA484	S1	T	BAT86	S1	T	BB204B	S1	T
BA682	S1/S7	T/Mm	BAV10	S1	SD	BB204G	S1	T
BA683	S1/S7	T/Mm	BAV18	S1	SD	BB212	S1	T
BAS11	S1	SD	BAV19	S1	SD	BB215	S7/S1	Mm/SD
BAS15	S1	SD	BAV20	S1	SD	BB219	S7/S1	Mm/SD
BAS16	S7/S1	Mm/SD	BAV21	S1	SD	BB405B	S1	T
BAS17	S7/S1	Mm/Vrg	BAV23	S7/S1	Mm/SD	BB417	S1	T
BAS19	S7/S1	Mm/SD	BAV45	S1	Sp	BB809	S1	T
BAS20	S7/S1	Mm/SD	BAV45A	S1	Sp	BB909A	S1	T
BAS21	S7/S1	Mm/SD	BAV70	S7/S1	Mm/SD	BB909B	S1	T
BAS28	S7/S1	Mm/SD	BAV74	S1	SD	BBY31	S7/S1	Mm/T

Mm = Microminiature semiconductors
for hybrid circuits
SD = Small-signal diodes

Sp = Special diodes
T = Tuner diodes
Vrg = Voltage regulator diodes

INDEX

type no.	book	section	type no.	book	section	type no.	book	section
BBY39	S1	T	BC639	S3	Sm	BCW69;R	S7	Mm
BBY40	S7/S1	Mm/T	BC640	S3	Sm	BCW70;R	S7	Mm
BC107	S3	Sm	BC807	S7	Mm	BCW71;R	S7	Mm
BC108	S3	Sm	BC808	S7	Mm	BCW72;R	S7	Mm
BC109	S3	Sm	BC817	S7	Mm	BCW81;R	S7	Mm
BC140	S3	Sm	BC818	S7	Mm	BCW89;R	S7	Mm
BC141	S3	Sm	BC846	S7	Mm	BCX17;R	S7	Mm
BC146	S3	Sm	BC847	S7	Mm	BCX18;R	S7	Mm
BC160	S3	Sm	BC848	S7	Mm	BCX19;R	S7	Mm
BC161	S3	Sm	BC849	S7	Mm	BCX20;R	S7	Mm
BC177	S3	Sm	BC850	S7	Mm	BCX51	S7	Mm
BC178	S3	Sm	BC856	S7	Mm	BCX52	S7	Mm
BC179	S3	Sm	BC857	S7	Mm	BCX53	S7	Mm
BC200	S3	Sm	BC858	S7	Mm	BCX54	S7	Mm
BC264A	S5	FET	BC859	S7	Mm	BCX55	S7	Mm
BC264B	S5	FET	BC860	S7	Mm	BCX56	S7	Mm
BC264C	S5	FET	BC868	S7	Mm	BCX70*	S7	Mm
BC264D	S5	FET	BC869	S7	Mm	BCX71*	S7	Mm
BC327;A	S3	Sm	BCF29;R	S7	Mm	BCY56	S3	Sm
BC328	S3	Sm	BCF30;R	S7	Mm	BCY57	S3	Sm
BC337;A	S3	Sm	BCF32;R	S7	Mm	BCY58	S3	Sm
BC338	S3	Sm	BCF33;R	S7	Mm	BCY59	S3	Sm
BC368	S3	Sm	BCF70;R	S7	Mm	BCY70	S3	Sm
BC369	S3	Sm	BCF81;R	S7	Mm	BCY71	S3	Sm
BC375	S3	Sm	BCV26	S7	Mm	BCY72	S3	Sm
BC376	S3	Sm	BCV27	S7	Mm	BCY78	S3	Sm
BC546	S3	Sm	BCV61	S7	Mm	BCY79	S3	Sm
BC547	S3	Sm	BCV62	S7	Mm	BCY87	S3	Sm
BC548	S3	Sm	BCV63	S7	Mm	BCY88	S3	Sm
BC549	S3	Sm	BCV64	S7	Mm	BCY89	S3	Sm
BC550	S3	Sm	BCV65	S7	Mm	BD131	S4a	P
BC556	S3	Sm	BCV71;R	S7	Mm	BD132	S4a	P
BC557	S3	Sm	BCV72;R	S7	Mm	BD135	S4a	P
BC558	S3	Sm	BCW29;R	S7	Mm	BD136	S4a	P
BC559	S3	Sm	BCW30;R	S7	Mm	BD137	S4a	P
BC560	S3	Sm	BCW31;R	S7	Mm	BD138	S4a	P
BC635	S3	Sm	BCW32;R	S7	Mm	BD139	S4a	P
BC636	S3	Sm	BCW33;R	S7	Mm	BD140	S4a	P
BC637	S3	Sm	BCW60*	S7	Mm	BD201	S4a	P
BC638	S3	Sm	BCW61*	S7	Mm	BD202	S4a	P

* = series

FET = Field-effect transistors

Mm = Microminiature semiconductors
for hybrid circuits

P = Low-frequency power transistors

Sm = Small-signal transistors

T = Tuner diodes

type no.	book	section	type no.	book	section	type no.	book	section
BD203	S4a	P	BD331	S4a	P	BD827	S4a	P
BD204	S4a	P	BD332	S4a	P	BD828	S4a	P
BD226	S4a	P	BD333	S4a	P	BD829	S4a	P
BD227	S4a	P	BD334	S4a	P	BD830	S4a	P
BD228	S4a	P	BD335	S4a	P	BD839	S4a	P
BD229	S4a	P	BD336	S4a	P	BD840	S4a	P
BD230	S4a	P	BD337	S4a	P	BD841	S4a	P
BD231	S4a	P	BD338	S4a	P	BD842	S4a	P
BD233	S4a	P	BD433	S4a	P	BD843	S4a	P
BD234	S4a	P	BD434	S4a	P	BD844	S4a	P
BD235	S4a	P	BD435	S4a	P	BD845	S4a	P
BD236	S4a	P	BD436	S4a	P	BD846	S4a	P
BD237	S4a	P	BD437	S4a	P	BD847	S4a	P
BD238	S4a	P	BD438	S4a	P	BD848	S4a	P
BD239	S4a	P	BD645	S4a	P	BD849	S4a	P
BD239A	S4a	P	BD646	S4a	P	BD850	S4a	P
BD239B	S4a	P	BD647	S4a	P	BD933	S4a	P
BD239C	S4a	P	BD648	S4a	P	BD934	S4a	P
BD240	S4a	P	BD649	S4a	P	BD935	S4a	P
BD240A	S4a	P	BD650	S4a	P	BD936	S4a	P
BD240B	S4a	P	BD651	S4a	P	BD937	S4a	P
BD240C	S4a	P	BD652	S4a	P	BD938	S4a	P
BD241	S4a	P	BD675	S4a	P	BD939	S4a	P
BD241A	S4a	P	BD676	S4a	P	BD940	S4a	P
BD241B	S4a	P	BD677	S4a	P	BD941	S4a	P
BD241C	S4a	P	BD678	S4a	P	BD942	S4a	P
BD242	S4a	P	BD679	S4a	P	BD943	S4a	P
BD242A	S4a	P	BD680	S4a	P	BD944	S4a	P
BD242B	S4a	P	BD681	S4a	P	BD945	S4a	P
BD242C	S4a	P	BD682	S4a	P	BD946	S4a	P
BD243	S4a	P	BD683	S4a	P	BD947	S4a	P
BD243A	S4a	P	BD684	S4a	P	BD948	S4a	P
BD243B	S4a	P	BD813	S4a	P	BD949	S4a	P
BD243C	S4a	P	BD814	S4a	P	BD950	S4a	P
BD244	S4a	P	BD815	S4a	P	BD951	S4a	P
BD244A	S4a	P	BD816	S4a	P	BD952	S4a	P
BD244B	S4a	P	BD817	S4a	P	BD953	S4a	P
BD244C	S4a	P	BD818	S4a	P	BD954	S4a	P
BD329	S4a	P	BD825	S4a	P	BD955	S4a	P
BD330	S4a	P	BD826	S4a	P	BD956	S4a	P

P = Low-frequency power transistors

INDEX

type no.	book	section	type no.	book	section	type no.	book	section
BDT20	S4a	P	BDT61B	S4a	P	BDV66A	S4a	P
BDT21	S4a	P	BDT61C	S4a	P	BDV66B	S4a	P
BDT29	S4a	P	BDT62	S4a	P	BDV66C	S4a	P
BDT29A	S4a	P	BDT62A	S4a	P	BDV66D	S4a	P
BDT29B	S4a	P	BDT62B	S4a	P	BDV67A	S4a	P
BDT29C	S4a	P	BDT62C	S4a	P	BDV67B	S4a	P
BDT30	S4a	P	BDT63	S4a	P	BDV67C	S4a	P
BDT30A	S4a	P	BDT63A	S4a	P	BDV67D	S4a	P
BDT30B	S4a	P	BDT63B	S4a	P	BDV91	S4a	P
BDT30C	S4a	P	BDT63C	S4a	P	BDV92	S4a	P
BDT31	S4a	P	BDT64	S4a	P	BDV93	S4a	P
BDT31A	S4a	P	BDT64A	S4a	P	BDV94	S4a	P
BDT31B	S4a	P	BDT64B	S4a	P	BDV95	S4a	P
BDT31C	S4a	P	BDT64C	S4a	P	BDV96	S4a	P
BDT32	S4a	P	BDT65	S4a	P	BDW55	S4a	P
BDT32A	S4a	P	BDT65A	S4a	P	BDW56	S4a	P
BDT32B	S4a	P	BDT65B	S4a	P	BDW57	S4a	P
BDT32C	S4a	P	BDT65C	S4a	P	BDW58	S4a	P
BDT41	S4a	P	BDT81	S4a	P	BDW59	S4a	P
BDT41A	S4a	P	BDT82	S4a	P	BDW60	S4a	P
BDT41B	S4a	P	BDT83	S4a	P	BDX35	S4a	P
BDT41C	S4a	P	BDT84	S4a	P	BDX36	S4a	P
BDT42	S4a	P	BDT85	S4a	P	BDX37	S4a	P
BDT42A	S4a	P	BDT86	S4a	P	BDX42	S4a	P
BDT42B	S4a	P	BDT87	S4a	P	BDX43	S4a	P
BDT42C	S4a	P	BDT88	S4a	P	BDX44	S4a	P
BDT51	S4a	P	BDT91	S4a	P	BDX45	S4a	P
BDT52	S4a	P	BDT92	S4a	P	BDX46	S4a	P
BDT53	S4a	P	BDT93	S4a	P	BDX47	S4a	P
BDT54	S4a	P	BDT94	S4a	P	BDX62	S4a	P
BDT55	S4a	P	BDT95	S4a	P	BDX62A	S4a	P
BDT56	S4a	P	BDT96	S4a	P	BDX62B	S4a	P
BDT57	S4a	P	BDV64	S4a	P	BDX62C	S4a	P
BDT58	S4a	P	BDV64A	S4a	P	BDX63	S4a	P
BDT60	S4a	P	BDV64B	S4a	P	BDX63A	S4a	P
BDT60A	S4a	P	BDV64C	S4a	P	BDX63B	S4a	P
BDT60B	S4a	P	BDV65	S4a	P	BDX63C	S4a	P
BDT60C	S4a	P	BDV65A	S4a	P	BDX64	S4a	P
BDT61	S4a	P	BDV65B	S4a	P	BDX64A	S4a	P
BDT61A	S4a	P	BDV65C	S4a	P	BDX64B	S4a	P

P = Low-frequency power transistors

type no.	book	section	type no.	book	section	type no.	book	section
BDX64C	S4a	P	BF247A	S5	FET	BF579	S7	Mm
BDX65	S4a	P	BF247B	S5	FET	BF583	S4b	HVP
BDX65A	S4a	P	BF247C	S5	FET	BF585	S4b	HVP
BDX65B	S4a	P	BF256A	S5	FET	BF587	S4b	HVP
BDX65C	S4a	P	BF256B	S5	FET	BF591	S4b	HVP
BDX66	S4a	P	BF256C	S5	FET	BF593	S4b	HVP
BDX66A	S4a	P	BF324	S3	Sm	BF620	S7	Mm
BDX66B	S4a	P	BF370	S3	Sm	BF621	S7	Mm
BDX66C	S4a	P	BF410A	S5	FET	BF622	S7	Mm
BDX67	S4a	P	BF410B	S5	FET	BF623	S7	Mm
BDX67A	S4a	P	BF410C	S5	FET	BF660;R	S7	Mm
BDX67B	S4a	P	BF410D	S5	FET	BF689K	S10	WBT
BDX67C	S4a	P	BF419	S4b	HVP	BF763	S10	WBT
BDX68	S4a	P	BF420	S3	Sm	BF767	S7	Mm
BDX68A	S4a	P	BF421	S3	Sm	BF819	S4b	HVP
BDX68B	S4a	P	BF422	S3	Sm	BF820	S7	Mm
BDX68C	S4a	P	BF423	S3	Sm	BF821	S7	Mm
BDX69	S4a	P	BF450	S3	Sm	BF822	S7	Mm
BDX69A	S4a	P	BF451	S3	Sm	BF823	S7	Mm
BDX69B	S4a	P	BF457	S4b	HVP	BF824	S7	Mm
BDX69C	S4a	P	BF458	S4b	HVP	BF840	S7	Mm
BDX77	S4a	P	BF459	S4b	HVP	BF841	S7	Mm
BDX78	S4a	P	BF469	S4b	HVP	BF857	S4b	HVP
BDX91	S4a	P	BF470	S4b	HVP	BF858	S4b	HVP
BDX92	S4a	P	BF471	S4b	HVP	BF859	S4b	HVP
BDX93	S4a	P	BF472	S4b	HVP	BF869	S4b	HVP
BDX94	S4a	P	BF483	S3	Sm	BF870	S4b	HVP
BDX95	S4a	P	BF485	S3	Sm	BF871	S4b	HVP
BDX96	S4a	P	BF487	S3	Sm	BF872	S4b	HVP
BDY90	S4a	P	BF494	S3	Sm	BF926	S3	Sm
BDY90A	S4a	P	BF495	S3	Sm	BF936	S3	Sm
BDY91	S4a	P	BF496	S3	Sm	BF939	S3	Sm
BDY92	S4a	P	BF510	S7/S5	Mm/FET	BF960	S5	FET
BF198	S3	Sm	BF511	S7/S5	Mm/FET	BF964	S5	FET
BF199	S3	Sm	BF512	S7/S5	Mm/FET	BF966	S5	FET
BF240	S3	Sm	BF513	S7/S5	Mm/FET	BF967	S3	Sm
BF241	S3	Sm	BF536	S7	Mm	BF970	S3	Sm
BF245A	S5	FET	BF550;R	S7	Mm	BF979	S3	Sm
BF245B	S5	FET	BF569	S7	Mm	BF980	S5	FET
BF245C	S5	FET	BF570	S7	Mm	BF981	S5	FET

FET = Field-effect transistors
HVP = High-voltage power transistors
Mm = Micronature semiconductors
for hybrid circuits

P = Low-frequency power transistors
Sm = Small-signal transistors
WBT = Wideband transistors

INDEX

type no.	book	section	type no.	book	section	type no.	book	section
BF982	S5	FET	BFQ32M	S10	WBT	BFR93R	S7	Mm
BF989	S7/S5	Mm/FET	BFQ32S	S10	WBT	BFR94	S10	WBT
BF990	S7/S5	Mm/FET	BFQ33	S10	WBT	BFR95	S10	WBT
BF991	S7/S5	Mm/FET	BFQ33C	S10	WBT	BFR96	S10	WBT
BF992	S7/S5	Mm/FET	BFQ34	S10	WBT	BFR96S	S10	WBT
BF994	S7/S5	Mm/FET	BFQ34T	S10	WBT	BFR101A;B	S7/S5	Mm/FET
BF994S	S7	Mm/FET	BFQ42	S6	RFP	BFS17	S7/S10	Mm/WBT
BF996	S7/S5	Mm/FET	BFQ43	S6	RFP	BFS17A	S10	WBT
BF996S	S7	Mm/FET	BFQ43S	S6	RFP	BFS17R	S7	Mm
BF997	S7	Mm/FET	BFQ51	S10	WBT	BFS18;R	S7	Mm
BFG23	S10	WBT	BFQ51C	S10	WBT	BFS19;R	S7	Mm
BFG32	S10	WBT	BFQ52	S10	WBT	BFS20;R	S7	Mm
BFG34	S10	WBT	BFQ53	S10	WBT	BFS21	S5	FET
BFG51	S10	WBT	BFQ63	S10	WBT	BFS21A	S5	FET
BFG65	S10	WBT	BFQ65	S10	WBT	BFS22A	S6	RFP
BFG67	S7	Mm	BFQ66	S10	WBT	BFS23A	S6	RFP
BFG90A	S10	WBT	BFQ67	S7/S10	Mm/WBT	BFT24	S10	WBT
BFG92A	S10	WBT	BFQ68	S10	WBT	BFT25	S7/S10	Mm/WBT
BFG93A	S10	WBT	BFQ136	S10	WBT	BFT25R	S7	Mm
BFG96	S10	WBT	BFR29	S5	FET	BFT44	S3	Sm
BFG195	S10	WBT	BFR30	S7/S5	Mm/FET	BFT45	S3	Sm
BFP90A	S10	WBT	BFR31	S7/S5	Mm/FET	BFT46	S7/S5	Mm/FET
BFP91A	S10	WBT	BFR49	S10	WBT	BFT92	S7/S10	Mm/WBT
BFP96	S10	WBT	BFR53	S7/S10	Mm/WBT	BFT92R	S7	Mm
BFQ10	S5	FET	BFR53R	S7	Mm	BFT93	S7/S10	Mm/WBT
BFQ11	S5	FET	BFR54	S3	Sm	BFT93R	S7	Mm
BFQ12	S5	FET	BFR64	S10	WBT	BFW10	S5	FET
BFQ13	S5	FET	BFR65	S10	WBT	BFW11	S5	FET
BFQ14	S5	FET	BFR84	S5	FET	BFW12	S5	FET
BFQ15	S5	FET	BFR90	S10	WBT	BFW13	S5	FET
BFQ16	S5	FET	BFR90A	S10	WBT	BFW16A	S10	WBT
BFQ17	S7/S10	Mm/WBT	BFR91	S10	WBT	BFW17A	S10	WBT
BFQ18A	S7/S10	Mm/WBT	BFR91A	S10	WBT	BFW30	S10	WBT
BFQ19	S7/S10	Mm/WBT	BFR92	S7/S10	Mm/WBT	BFW61	S5	FET
BFQ22S	S10	WBT	BFR92A	S7/S10	Mm/WBT	BFW92	S10	WBT
BFQ23	S10	WBT	BFR92AR	S7	Mm	BFW92A	S10	WBT
BFQ23C	S10	WBT	BFR92R	S7	Mm	BFW93	S10	WBT
BFQ24	S10	WBT	BFR93	S7/S10	Mm/WBT	BFX29	S3	Sm
BFQ32	S10	WBT	BFR93A	S7/S10	Mm/WBT	BFX30	S3	Sm
BFQ32C	S10	WBT	BFR93AR	S7	Mm	BFX34	S3	Sm

* = series

FET = Field-effect transistors

Mm = Microminiature semiconductors
for hybrid circuits

RFP = R.F. power transistors and modules

RT = Tripler

Sm = Small-signal transistors

ThM = Thyristor modules

WBM = Wideband hybrid IC modules

WBT = Wideband transistors

type no.	book	section	type no.	book	section	type no.	book	section
BFX84	S3	Sm	BGY51	S10	WBM	BLF242	S6	RFP/FET
BFX85	S3	Sm	BGY52	S10	WBM	BLF244	S6	RFP/FET
BFX86	S3	Sm	BGY53	S10	WBM	BLF245	S6	RFP/FET
BFX87	S3	Sm	BGY54	S10	WBM	BLT90/SL	S6	RFP
BFX88	S3	Sm	BGY55	S10	WBM	BLT91/SL	S6	RFP
BFX89	S10	WBT	BGY56	S10	WBM	BLT92/SL	S6	RFP
BFY50	S3	Sm	BGY57	S10	WBM	BLU20/12	S6	RFP
BFY51	S3	Sm	BGY58	S10	WBM	BLU30/12	S6	RFP
BFY52	S3	Sm	BGY58A	S10	WBM	BLU45/12	S6	RFP
BFY55	S3	Sm	BGY59	S10	WBM	BLU50	S6	RFP
BFY90	S10	WBT	BGY60	S10	WBM	BLU51	S6	RFP
BG2000	S1	RT	BGY61	S10	WBM	BLU52	S6	RFP
BG2097	S1	RT	BGY65	S10	WBM	BLU53	S6	RFP
BGD102	S10	WBM	BGY67	S10	WBM	BLU60/12	S6	RFP
BGD102E	S10	WBM	BGY67A	S10	WBM	BLU97	S6	RFP
BGD104	S10	WBM	BGY70	S10	WBM	BLU98	S6	RFP
BGD104E	S10	WBM	BGY71	S10	WBM	BLU99	S6	RFP
BGD502	S10	WBM	BGY74	S10	WBM	BLV10	S6	RFP
BGD504	S10	WBM	BGY75	S10	WBM	BLV11	S6	RFP
BGX885	S10	WBM	BGY78	S10	WBM	BLV20	S6	RFP
BGY22	S6	RFP	BGY84	S10	WBM	BLV21	S6	RFP
BGY22A	S6	RFP	BGY84A	S10	WBM	BLV25	S6	RFP
BGY23	S6	RFP	BGY85	S10	WBM	BLV30	S6	RFP
BGY23A	S6	RFP	BGY85A	S10	WBM	BLV30/12	S6	RFP
BGY32	S6	RFP	BGY86	S10	WBM	BLV31	S6	RFP
BGY33	S6	RFP	BGY87	S10	WBM	BLV32F	S6	RFP
BGY35	S6	RFP	BGY88	S10	WBM	BLV33	S6	RFP
BGY36	S6	RFP	BGY90A	S6	RFP	BLV33F	S6	RFP
BGY40A	S6	RFP	BGY90B	S6	RFP	BLV36	S6	RFP
BGY40B	S6	RFP	BGY93 *	S6	RFP	BLV45/12	S6	RFP
BGY41A	S6	RFP	BGY94 *	S6	RFP	BLV57	S6	RFP
BGY41B	S6	RFP	BGY95A	S6	RFP	BLV59	S6	RFP
BGY43	S6	RFP	BGY95B	S6	RFP	BLV75/12	S6	RFP
BGY45A	S6	RFP	BGY96A	S6	RFP	BLV80/28	S6	RFP
BGY45B	S6	RFP	BGY96B	S6	RFP	BLV90	S6	RFP
BGY46A	S6	RFP	BGY584A	S10	WBM	BLV90/SL	S6	RFP
BGY46B	S6	RFP	BGY585A	S10	WBM	BLV91	S6	RFP
BGY47 *	S6	RFP	BGY586	S10	WBM	BLV91/SL	S6	RFP
BGY48 *	S6	RFP	BGY587	S10	WBM	BLV92	S6	RFP
BGY50	S10	WBM	BLF146	S6	RFP/FET	BLV93	S6	RFP

* = series

FET = Field-effect transistors

RFP = R.F. power transistors and modules

ThM = Thyristor modules

WBM = Wideband hybrid IC modules

INDEX

type no.	book	section	type no.	book	section	type no.	book	section
BLV94	S6	RFP	BLX67	S6	RFP	BR100/03	S2b	Th
BLV95	S6	RFP	BLX68	S6	RFP	BR101	S3	Sm
BLV97	S6	RFP	BLX69A	S6	RFP	BR210*	S2a	Th
BLV98	S6	RFP	BLX91A	S6	RFP	BR216*	S2a	Th
BLV99	S6	RFP	BLX91CB	S6	RFP	BR220*	S2a	Th
BLW29	S6	RFP	BLX92A	S6	RFP	BRY39	S3	Sm
BLW31	S6	RFP	BLX93A	S6	RFP	BRY56	S3	Sm
BLW32	S6	RFP	BLX94A	S6	RFP	BRY61	S7	Mm
BLW33	S6	RFP	BLX94C	S6	RFP	BRY62	S7	Mm
BLW34	S6	RFP	BLX95	S6	RFP	BS107	S5	FET
BLW50F	S6	RFP	BLX96	S6	RFP	BS170	S5	FET
BLW60	S6	RFP	BLX97	S6	RFP	BSD10	S5	FET
BLW60C	S6	RFP	BLX98	S6	RFP	BSD12	S5	FET
BLW76	S6	RFP	BLY87A	S6	RFP	BSD20	S5/7	FET
BLW77	S6	RFP	BLY87C	S6	RFP	BSD22	S5/7	FET
BLW78	S6	RFP	BLY88A	S6	RFP	BSD212	S5	FET
BLW79	S6	RFP	BLY88C	S6	RFP	BSD213	S5	FET
BLW80	S6	RFP	BLY89A	S6	RFP	BSD214	S5	FET
BLW81	S6	RFP	BLY89C	S6	RFP	BSD215	S5	FET
BLW83	S6	RFP	BLY90	S6	RFP	BSR12;R	S7	Mm
BLW84	S6	RFP	BLY91A	S6	RFP	BSR13;R	S7	Mm
BLW85	S6	RFP	BLY91C	S6	RFP	BSR14;R	S7	Mm
BLW86	S6	RFP	BLY92A	S6	RFP	BSR15;R	S7	Mm
BLW87	S6	RFP	BLY92C	S6	RFP	BSR16;R	S7	Mm
BLW89	S6	RFP	BLY93A	S6	RFP	BSR17;R	S7	Mm
BLW90	S6	RFP	BLY93C	S6	RFP	BSR17A;R	S7	Mm
BLW91	S6	RFP	BLY94	S6	RFP	BSR18;R	S7	Mm
BLW95	S6	RFP	BPF24	S8b	PDT	BSR18A;R	S7	Mm
BLW96	S6	RFP	BPW22A	S8a/b	PDT	BSR19;A	S7	Mm
BLW97	S6	RFP	BPW50	S8a/b	PDT	BSR20;A	S7	Mm
BLW98	S6	RFP	BPW71	S8b	PDT	BSR30	S7	Mm
BLW99	S6	RFP	BPX25	S8b	PDT	BSR31	S7	Mm
BLX13	S6	RFP	BPX29	S8b	PDT	BSR32	S7	Mm
BLX13C	S6	RFP	BPX40	S8b	PDT	BSR33	S7	Mm
BLX14	S6	RFP	BPX41	S8b	PDT	BSR40	S7	Mm
BLX15	S6	RFP	BPX42	S8b	PDT	BSR41	S7	Mm
BLX39	S6	RFP	BPX61	S8b	PDT	BSR42	S7	Mm
BLX65	S6	RFP	BPX61P	S8b	PDT	BSR43	S7	Mm
BLX65E	S6	RFP	BPX71	S8b	PDT	BSR50	S3	Sm
BLX65ES	S6	RFP	BPX72	S8b	PDT	BSR51	S3	Sm

FET = Field-effect transistors

Mm = Microminiature semiconductors
for hybrid circuits

PDT = Photodiodes or transistors

RFP = R.F. power transistors and modules

Sm = Small-signal transistors

Th = Thyristors

type no.	book	section	type no.	book	section	type no.	book	section
BSR52	S3	Sm	BST110	S5	FET	BT169*	S2b	Th
BSR56	S7/S5	Mm/FET	BST120	S5/S7	FET/Mm	BTA140*	S2b	Tri
BSR57	S7/S5	Mm/FET	BST122	S5/S7	FET/Mm	BTR59*	S2b	Tri
BSR58	S7/S5	Mm/FET	BSV15	S3	Sm	BTS59*	S2b	Tri
BSR60	S3	Sm	BSV16	S3	Sm	BTV58*	S2b	Th
BSR61	S3	Sm	BSV17	S3	Sm	BTV59*	S2b	Th
BSR62	S3	Sm	BSV52;R	S7	Mm	BTV59D*	S2b	Th
BSS38	S3	Sm	BSV64	S3	Sm	BTV60*	S2b	Th
BSS50	S3	Sm	BSV78	S5	FET	BTV60D*	S2b	Th
BSS51	S3	Sm	BSV79	S5	FET	BTV70*	S2b	Th
BSS52	S3	Sm	BSV80	S5	FET	BTV70D*	S2b	Th
BSS60	S3	Sm	BSV81	S5	FET	BTW23*	S2b	Th
BSS61	S3	Sm	BSW66A	S3	Sm	BTW38*	S2b	Th
BSS62	S3	Sm	BSW67A	S3	Sm	BTW40*	S2b	Th
BSS63;R	S7	Mm	BSW68A	S3	Sm	BTW42*	S2b	Th
BSS64;R	S7	Mm	BSX19	S3	Sm	BTW43*	S2b	Tri
BSS68	S3	Sm	BSX20	S3	Sm	BTW45*	S2b	Th
BSS83	S5/7	FET/Mm	BSX45	S3	Sm	BTW58*	S2b	Th
BST15	S7	Mm	BSX46	S3	Sm	BTW62*	S2b	Th
BST16	S7	Mm	BSX47	S3	Sm	BTW62D*	S2b	Th
BST39	S7	Mm	BSX59	S3	Sm	BTW63*	S2b	Th
BST40	S7	Mm	BSX60	S3	Sm	BTY79*	S2b	Th
BST50	S7	Mm	BSX61	S3	Sm	BTY91*	S2b	Th
BST51	S7	Mm	BSY95A	S3	Sm	BU426	S4b	SP
BST52	S7	Mm	BT136*	S2b	Tri	BU426A	S4b	SP
BST60	S7	Mm	BT136F*	S2b	Tri	BU433	S4b	SP
BST61	S7	Mm	BT137*	S2b	Tri	BU505	S4b	SP
BST62	S7	Mm	BT137F*	S2b	Tri	BU506	S4b	SP
BST70A	S5	FET	BT138*	S2b	Tri	BU506D	S4b	SP
BST72A	S5	FET	BT138F*	S2b	Tri	BU508A	S4b	SP
BST74A	S5	FET	BT139*	S2b	Tri	BU508D	S4b	SP
BST76A	S5	FET	BT139F*	S2b	Tri	BU705	S4b	SP
BST78	S5	FET	BT145*	S2b	Tri	BU706	S4b	SP
BST80	S5/S7	FET/Mm	BT149*	S2b	Th	BU706D	S4b	SP
BST82	S5/S7	FET/Mm	BT150	S2b	Th	BU806	S4b	SP
BST84	S5/S7	FET/Mm	BT151*	S2b	Th	BU807	S4b	SP
BST86	S5/S7	FET/Mm	BT151F*	S2b	Th	BU808	S4b	SP
BST90	S5	FET	BT152*	S2b	Th	BU824	S4b	SP
BST97	S5	FET	BT153	S2b	Th	BU826	S4b	SP
BST100	S5	FET	BT157*	S2b	Th	BUP22*	S4b	SP

* = series

FET = Field-effect transistors

Mm = Microminiature semiconductors
for hybrid circuits

Sm = Small-signal transistors

SP = Low-frequency switching power transistors

Th = Thyristors

Tri = Triacs

INDEX

type no.	book	section	type no.	book	section	type no.	book	section
BUP23*	S4b	SP	BUZ10A	S9	PM	BUZ72A	S9	PM
BUS11;A	S4b	SP	BUZ11	S9	PM	BUZ73A	S9	PM
BUS12;A	S4b	SP	BUZ11A	S9	PM	BUZ74	S9	PM
BUS13;A	S4b	SP	BUZ14	S9	PM	BUZ74A	S9	PM
BUS14;A	S4b	SP	BUZ15	S9	PM	BUZ76	S9	PM
BUS21*	S4b	SP	BUZ20	S9	PM	BUZ76A	S9	PM
BUS22*	S4b	SP	BUZ21	S9	PM	BUZ80	S9	PM
BUS23*	S4b	SP	BUZ23	S9	PM	BUZ80A	S9	PM
BUT11;A	S4b	SP	BUZ24	S9	PM	BUZ83	S9	PM
BUT11A	S4b	SP	BUZ25	S9	PM	BUZ83A	S9	PM
BUT11AF	S4b	SP	BUZ30	S9	PM	BUZ84	S9	PM
BUV82	S4b	SP	BUZ31	S9	PM	BUZ84A	S9	PM
BUV83	S4b	SP	BUZ32	S9	PM	BY224*	S2a	R
BUV89	S4b	SP	BUZ33	S9	PM	BY225*	S2a	R
BUV90;A	S4b	SP	BUZ34	S9	PM	BY228	S1	R
BUW11;A	S4b	SP	BUZ35	S9	PM	BY229*	S2a	R
BUW12;A	S4b	SP	BUZ36	S9	PM	BY229F*	S2a	R
BUW13;A	S4b	SP	BUZ40	S9	PM	BY249*	S2a	R
BUW84	S4b	SP	BUZ41A	S9	PM	BY260*	S2a	R
BUW85	S4b	SP	BUZ42	S9	PM	BY261*	S2a	R
BUX46;A	S4b	SP	BUZ43	S9	PM	BY329*	S2a	R
BUX47;A	S4b	SP	BUZ44A	S9	PM	BY359*	S2a	R
BUX48;A	S4b	SP	BUZ45	S9	PM	BY438	S1	R
BUX80	S4b	SP	BUZ45A	S9	PM	BY448	S1	R
BUX81	S4b	SP	BUZ45B	S9	PM	BY458	S1	R
BUX82	S4b	SP	BUZ45C	S9	PM	BY505	S1	R
BUX83	S4b	SP	BUZ46	S9	PM	BY509	S1	R
BUX84	S4b	SP	BUZ50A	S9	PM	BY527	S1	R
BUX84F	S4b	SP	BUZ50B	S9	PM	BY584	S1	R
BUX85	S4b	SP	BUZ53A	S9	PM	BY588	S1	R
BUX85F	S4b	SP	BUZ54	S9	PM	BY609	S1	R
BUX86	S4b	SP	BUZ54A	S9	PM	BY610	S1	R
BUX87	S4b	SP	BUZ60	S9	PM	BY614	S1	R
BUX88	S4b	SP	BUZ60B	S9	PM	BY619	S1	R
BUX90	S4b	SP	BUZ63	S9	PM	BY620	S1	R
BUX98	S4b	SP	BUZ63B	S9	PM	BY627	S1	R
BUX98A	S4b	SP	BUZ64	S9	PM	BY707	S1	R
BUX99	S4b	SP	BUZ71	S9	PM	BY708	S1	R
BUY89	S4b	SP	BUZ71A	S9	PM	BY709	S1	R
BUZ10	S9	PM	BUZ72	S9	PM	BY710	S1	R

* = series

PM = Power MOS transistors

R = Rectifier diodes

SP = Low-frequency switching power transistors

type no.	book	section	type no.	book	section	type no.	book	section
BY711	S1	R	BYV33*	S2a	R	BYX39*	S2a	R
BY712	S1	R	BYV33F*	S2a	R	BYX42*	S2a	R
BY713	S1	R	BYV34*	S2a	R	BYX46*	S2a	R
BY714	S1	R	BYV36 *	S1	R	BYX50*	S2a	R
BYD13 *	S1	R	BYV39*	S2a	R	BYX52*	S2a	R
BYD14 *	S1	R	BYV42*	S2a	R	BYX56*	S2a	R
BYD17 *	S1	R	BYV43*	S2a	R	BYX90G	S1	R
BYD33 *	S1	R	BYV43F*	S2a	R	BYX96*	S2a	R
BYD37 *	S1	R	BYV44*	S2a	R	BYX97*	S2a	R
BYD73 *	S1	R	BYV60*	S2a	R	BYX98*	S2a	R
BYD74 *	S1	R	BYV72*	S2a	R	BYX99*	S2a	R
BYD77 *	S1	R	BYV73*	S2a	R	BZD23	S1	Vrg
BYM26 *	S1	R	BYV74*	S2a	R	BZD27	S1	Vrg
BYM36 *	S1	R	BYV79*	S2a	R	BZT03	S1	Vrg
BYM56 *	S1	R	BYV92*	S2a	R	BZV10	S1	Vrf
BYP21*	S2a	R	BYV95A	S1	R	BZV11	S1	Vrf
BYP22*	S2a	R	BYV95B	S1	R	BZV12	S1	Vrf
BYP59*	S2a	R	BYV95C	S1	R	BZV13	S1	Vrf
BYQ28*	S2a	R	BYV96D	S1	R	BZV14	S1	Vrf
BYR29*	S2a	R	BYV96E	S1	R	BZV37	S1	Vrf
BYR29F*	S2a	R	BYW25*	S2a	R	BZV46	S1	Vrg
BYT28*	S2a	R	BYW29*	S2a	R	BZV49*	S1/S7	Vrg/Mm
BYT79*	S2a	R	BYW29F*	S2a	R	BZV55*	S7	Mm
BYV10	S1	R	BYW30*	S2a	R	BZV80	S1	Vrf
BYV18*	S2a	R	BYW31*	S2a	R	BZV81	S1	Vrf
BYV19*	S2a	R	BYW54	S1	R	BZV85 *	S1	Vrg
BYV20*	S2a	R	BYW55	S1	R	BZW03 *	S1	Vrg
BYV21*	S2a	R	BYW56	S1	R	BZW14	S1	Vrg
BYV22*	S2a	R	BYW92*	S2a	R	BZW86*	S2a	TS
BYV23*	S2a	R	BYW93*	S2a	R	BZX55 *	S1	Vrg
BYV24*	S2a	R	BYW95A	S1	R	BZX70*	S2a	Vrg
BYV26 *	S1/S2a	R	BYW95B	S1	R	BZX75 *	S1	Vrg
BYV27*	S1/S2a	R	BYW95C	S1	R	BZX79*	S1	Vrg
BYV28*	S1/S2a	R	BYW96D	S1	R	BZX84*	S7/S1	Mm/Vrg
BYV29*	S2a	R	BYW96E	S1	R	BZY91*	S2a	Vrg
BYV29F*	S2a	R	BYX10G	S1	R	BZY93*	S2a	Vrg
BYV30*	S2a	R	BYX25*	S2a	R	CFX13	S11	M
BYV31*	S2a	R	BYX30*	S2a	R	CFX21	S11	M
BYV32*	S2a	R	BYX32*	S2a	R	CFX30	S11	M
BYV32F*	S2a	R	BYX38*	S2a	R	CFX31	S11	M

* = series

LED = Light-emitting diodes

M = Microwave transistors

Mm = Microminiature semiconductors
for hybrid circuits

Ph = Photoconductive devices

PhC = Photocouplers

R = Rectifier diodes

TS = Transient suppressor diodes

Vrf = Voltage reference diodes

Vrg = Voltage regulator diodes

INDEX

type no.	book	section	type no.	book	section	type no.	book	section
CFX32	S11	M	CQS54	S8a	LED	CQW60A(L)	S8a	LED
CFX33	S11	M	CQS82L	S8a	LED	CQW60U(L)	S8a	LED
CNG35	S8b	PhC	CQS82AL	S8a	LED	CQW61(L)	S8a	LED
CNG36	S8b	PhC	CQS84L	S8a	LED	CQW62(L)	S8a	LED
CNR36	S8b	PhC	CQS86L	S8a	LED	CQW89A	S8a/b	I
CNX21	S8b	PhC	CQS93	S8a	LED	CQW93	S8a	LED
CNX35	S8b	PhC	CQS93E	S8a	LED	CQW95	S8a	LED
CNX35U	S8b	PhC	CQS93L	S8a	LED	CQW97	S8a	LED
CNX36	S8b	PhC	CQS95	S8a	LED	CQX24(L)	S8a	LED
CNX36U	S8b	PhC	CQS95E	S8a	LED	CQX51(L)	S8a	LED
CNX38	S8b	PhC	CQS95L	S8a	LED	CQX54(L)	S8a	LED
CNX38U	S8b	PhC	CQS97	S8a	LED	CQX54D	S8a	LED
CNX39	S8b	PhC	CQS97E	S8a	LED	CQX64(L)	S8a	LED
CNX39U	S8b	PhC	CQS97L	S8a	LED	CQX64D	S8a	LED
CNX44	S8b	PhC	CQT10B	S8a	LED	CQX74(L)	S8a	LED
CNX44A	S8b	PhC	CQT24	S8a	LED	CQX74D	S8a	LED
CNX46	S8b	PhC	CQT60	S8a	LED	CQY11B	S8b	LED
CNX48	S8b	PhC	CQT70	S8a	LED	CQY11C	S8b	LED
CNX48U	S8b	PhC	CQT80L	S8a	LED	CQY24B(L)	S8a	LED
CNX62	S8b	PhC	CQV70(L)	S8a	LED	CQY49B	S8b	LED
CNX72	S8b	PhC	CQV70A(L)	S8a	LED	CQY49C	S8b	LED
CNX82	S8b	PhC	CQV70U(L)	S8a	LED	CQY50	S8b	LED
CNX83	S8b	PhC	CQV71A(L)	S8a	LED	CQY52	S8b	LED
CNX91	S8b	PhC	CQV72(L)	S8a	LED	CQY53S	S8b	LED
CNX92	S8b	PhC	CQV80L	S8a	LED	CQY54A	S8a	LED
CNY17-1	S8b	PhC	CQV80AL	S8a	LED	CQY58A	S8a/b	I
CNY17-2	S8b	PhC	CQV80UL	S8a	LED	CQY89A	S8a/b	I
CNY17-3	S8b	PhC	CQV81L	S8a	LED	CQY94B(L)	S8a	LED
CNY50	S8b	PhC	CQV82L	S8a	LED	CQY95B	S8a	LED
CNY57	S8b	PhC	CQW10A(L)	S8a	LED	CQY96(L)	S8a	LED
CNY57A	S8b	PhC	CQW10B(L)	S8a	LED	CQY97A	S8a	LED
CNY57AU	S8b	PhC	CQW10U(L)	S8a	LED	Fresnel-	S8b	A
CNY57U	S8b	PhC	CQW11B(L)	S8a	LED	lens		
CNY62	S8b	PhC	CQW12B(L)	S8a	LED	H11A1	S8b	PhC
CNY63	S8b	PhC	CQW20A	S8a	LED	H11A2	S8b	PhC
CQF24	S8b	Ph	CQW21	S8a	LED	H11A3	S8b	PhC
CQL10A	S8b	Ph	CQW22	S8a	LED	H11A4	S8b	PhC
CQL13A	S8b	Ph	CQW24(L)	S8a	LED	H11A5	S8b	PhC
CQL16	S8b	Ph	CQW54	S8a	LED	H11B1	S8b	PhC
CQS51L	S8a	LED	CQW60(L)	S8a	LED	H11B2	S8b	PhC

* = series

A = Accessories

I = Infrared devices

LED = Light-emitting diodes

M = Microwave transistors

PhC = Photocouplers

SEN = Sensors

type no.	book	section	type no.	book	section	type no.	book	section
H11B3	S8b	PhC	LTE42005S	S11	M	OM345	S10	WBM
H11B255	S8b	PhC	LTE42008R	S11	M	OM350	S10	WBM
KMZ10A	S13	SEN	LTE42012R	S11	M	OM360	S10	WBM
KMZ10B	S13	SEN	LV1721E50R	S11	M	OM361	S10	WBM
KMZ10C	S13	SEN	LV2024E45R	S11	M	OM370	S10	WBM
KP100A	S13	SEN	LV2327E40R	S11	M	OM386B	S13	SEN
KP101A	S13	SEN	LV3742E16R	S11	M	OM386M	S13	SEN
KPZ20G	S13	SEN	LV3742E24R	S11	M	OM387B	S13	SEN
KPZ21G	S13	SEN	LWE2015R	S11	M	OM387M	S13	SEN
KTY81*	S13	SEN	LWE2025R	S11	M	OM388B	S13	SEN
KTY83*	S13	SEN	LZ1418E100RS11		M	OM389B	S13	SEN
KTY84*	S13	SEN	MCA230	S8b	PhC	OM931	S4a	P
LAE2001R	S11	M	MCA231	S8b	PhC	OM961	S4a	P
LAE4001Q	S11	M	MCA255	S8b	PhC	OSB9115	S2a	St
LAE4001R	S11	M	MCT2	S8b	PhC	OSB9215	S2a	St
LAE4002S	S11	M	MCT26	S8b	PhC	OSB9415	S2a	St
LAE6000Q	S11	M	MKB12040WS	S11	M	OSM9115	S2a	St
LBE1004R	S11	M	MKB12100WS	S11	M	OSM9215	S2a	St
LBE1010R	S11	M	MKB12140W	S11	M	OSM9415	S2a	St
LBE2003S	S11	M	MO6075B200ZS11		M	OSM9510	S2a	St
LBE2005Q	S11	M	MO6075B400ZS11		M	OSM9511	S2a	St
LBE2008T	S11	M	MRB12175YR	S11	M	OSM9512	S2a	St
LBE2009S	S11	M	MRB12350YR	S11	M	OSS9115	S2a	St
LCE1010R	S11	M	MS1011B700YS11		M	OSS9215	S2a	St
LCE2003S	S11	M	MS6075B800ZS11		M	OSS9415	S2a	St
LCE2005Q	S11	M	MSB12900Y	S11	M	P2105	S8b	I
LCE2008T	S11	M	MZ0912B75Y	S11	M	PBMF4391	S5	FET
LCE2009S	S11	M	MZ0912B150YS11		M	PBMF4392	S5	FET
LJE42002T	S11	M	OM286; M	S13	SEN	PBMF4393	S5	FET
LKE1004R	S11	M	OM287; M	S13	SEN	PDE1001U	S11	M
LKE2002T	S11	M	OM320	S10	WBM	PDE1003U	S11	M
LKE2004T	S11	M	OM321	S10	WBM	PDE1005U	S11	M
LKE2015T	S11	M	OM322	S10	WBM	PDE1010U	S11	M
LKE21004R	S11	M	OM323	S10	WBM	PEE1001U	S11	M
LKE21015T	S11	M	OM323A	S10	WBM	PEE1003U	S11	M
LKE21050T	S11	M	OM335	S10	WBM	PEE1005U	S11	M
LKE27010R	S11	M	OM336	S10	WBM	PEE1010U	S11	M
LKE27025R	S11	M	OM337	S10	WBM	PH2222;R	S3	Sm
LKE32002T	S11	M	OM337A	S10	WBM	PH2222A;R	S3	Sm
LKE32004T	S11	M	OM339	S10	WBM	PH2369	S3	Sm

FET = Field-effect transistors
 I = Infrared devices
 M = Microwave transistors
 Mm = Microminiature semiconductors
 for hybrid circuits
 P = Low-frequency power transistors
 PhC = Photocouplers

R = Rectifier diodes
 SD = Small-signal diodes
 SEN = Sensors
 Sm = Small-signal transistors
 SP = Low-frequency switching power transistors
 St = Rectifier stacks
 WBM = Wideband hybrid IC modules

INDEX

type no.	book	section	type no.	book	section	type no.	book	section
PH2907;R	S3	Sm	PMLL4448	S1	SD	RZ1214B60W	S11	M
PH2907A;R	S3	Sm	PMLL5225B			RZ1214B65Y	S11	M
PH2955T	S4a	P	to	S1/S7	SD	RZ1214B125WS11		M
PH3055T	S4a	P	PMLL5267B			RZ1214B125YS11		M
PH5415	S3	Sm	P044	S8b	PhC	RZ1214B150YS11		M
PH5416	S3	Sm	P044A	S8b	PhC	RZ2833B45W	S11	M
PH13002	S4b	SP	PPC5001T	S11	M	RZ3135B15U	S11	M
PH13003	S4b	SP	PQC5001T	S11	M	RZ3135B15W	S11	M
PHSD51	S2a	R	PTB23001X	S11	M	RZ3135B25U	S11	M
PKB3001U	S11	M	PTB23003X	S11	M	RZ3135B30W	S11	M
PKB3003U	S11	M	PTB23005X	S11	M	RZB12100Y	S11	M
PKB3005U	S11	M	PTB32001X	S11	M	RZB12350Y	S11	M
PKB12005U	S11	M	PTB32003X	S11	M	RZZ1214B300YS11		M
PKB20010U	S11	M	PTB32005X	S11	M	SL5500	S8b	PhC
PKB23001U	S11	M	PTB42001X	S11	M	SL5501	S8b	PhC
PKB23003U	S11	M	PTB42002X	S11	M	SL5502R	S8b	PhC
PKB23005U	S11	M	PTB42003X	S11	M	SL5504	S8b	PhC
PKB25006T	S11	M	PV3742B4X	S11	M	SL5504S	S8b	PhC
PKB32001U	S11	M	PVB42004X	S11	M	SL5505S	S8b	PhC
PKB32003U	S11	M	PXT3904	S7	Mm	SL5511	S8b	PhC
PKB32005U	S11	M	PXT3906	S7	Mm	TIP29*	S4a	P
PMBF4391	S7	Mm	PZ1418B15U	S11	M	TIP30*	S4a	P
PMBF4392	S7	Mm	PZ1418B30U	S11	M	TIP31*	S4a	P
PMBF4392	S7	Mm	PZ1721B12U	S11	M	TIP32*	S4a	P
PMBT2222/A	S7	Mm	PZ1721B25U	S11	M	TIP33*	S4a	P
PMBT2907/A	S7	Mm	PZ2024B10U	S11	M	TIP34*	S4a	P
PMBT3903/4	S7	Mm	PZ2024B20U	S11	M	TIP41*	S4a	P
PMBT3906	S7	Mm	PZB16035U	S11	M	TIP42*	S4a	P
PMBT6428/9	S7	Mm	PZB27020U	S11	M	TIP47	S4a	P
PMBTA05/06	S7	Mm	RPY97	S8b	I	TIP48	S4a	P
PMBTA13/14	S7	Mm	RPY100	S8b	I	TIP49	S4a	P
PMBTA42/43	S7	Mm	RPY101	S8b	I	TIP50	S4a	P
PMBTA55/56	S7	Mm	RPY102	S8b	I	TIP110	S4a	P
PMBTA63/64	S7	Mm	RPY103	S8b	I	TIP111	S4a	P
PMBTA92/93	S7	Mm	RPY107	S8b	I	TIP112	S4a	P
PMLL4148	S1	SD	RPY109	S8b	I	TIP115	S4a	P
PMLL4150	S1	SD	RV3135B5X	S11	M	TIP116	S4a	P
PMLL4151	S1	SD	RX1214B300YS11		M	TIP117	S4a	P
PMLL4153	S1	SD	RXB12350Y	S11	M	TIP120	S4a	P
PMLL4446	S1	SD	RZ1214B35Y	S11	M	TIP121	S4a	P

* = series

I = Infrared devices

M = Microwave transistors

P = Low-frequency power transistors

PhC = Photocouplers

R = Rectifier diodes

SD = Small-signal diodes

Vrf = Voltage reference diodes

type no.	book	section	type no.	book	section	type no.	book	section
TIP122	S4a	P	1N4002G	S1	R	2N2905A	S3	Sm
TIP125	S4a	P	1N4003G	S1	R	2N2906	S3	Sm
TIP126	S4a	P	1N4004G	S1	R	2N2906A	S3	Sm
TIP127	S4a	P	1N4005G	S1	R	2N2907	S3	Sm
TIP130	S4a	P	1N4006G	S1	R	2N2907A	S3	Sm
TIP131	S4a	P	1N4007G	S1	R	2N3019	S3	Sm
TIP132	S4a	P	1N4148	S1	SD	2N3020	S3	Sm
TIP135	S4a	P	1N4150	S1	SD	2N3053	S3	Sm
TIP136	S4a	P	1N4151	S1	SD	2N3375	S6	RFP
TIP137	S4a	P	1N4153	S1	SD	2N3553	S6	RFP
TIP140	S4a	P	1N4446	S1	SD	2N3632	S6	RFP
TIP141	S4a	P	1N4448	S1	SD	2N3822	S5	FET
TIP145	S4a	P	1N4531	S1	SD	2N3823	S5	FET
TIP146	S4a	P	1N4532	S1	SD	2N3866	S6	RFP
TIP147	S4a	P	1N5059	S1	R	2N3903	S3	Sm
TIP2955	S4a	P	1N5060	S1	R	2N3904	S3	Sm
TIP3055	S4a	P	1N5061	S1	R	2N3905	S3	Sm
1N821;A	S1	Vrf	1N5062	S1	R	2N3906	S3	Sm
1N823;A	S1	Vrf	1N5225B			2N3924	S6	RFP
1N825;A	S1	Vrf	to	S1	SD	2N3926	S6	RFP
1N827;A	S1	Vrf	1N5267B			2N3927	S6	RFP
1N829;A	S1	Vrf	2N918	S10	WBT	2N3966	S5	FET
1N914	S1	SD	2N929	S3	Sm	2N4030	S3	Sm
1N916	S1	SD	2N930	S3	Sm	2N4031	S3	Sm
1N3879	S2a	R	2N1613	S3	Sm	2N4032	S3	Sm
1N3880	S2a	R	2N1711	S3	Sm	2N4033	S3	Sm
1N3881	S2a	R	2N1893	S3	Sm	2N4091	S5	FET
1N3882	S2a	R	2N2219	S3	Sm	2N4092	S5	FET
1N3883	S2a	R	2N2219A	S3	Sm	2N4093	S5	FET
1N3889	S2a	R	2N2222	S3	Sm	2N4123	S3	Sm
1N3890	S2a	R	2N2222A	S3	Sm	2N4124	S3	Sm
1N3891	S2a	R	2N2297	S3	Sm	2N4125	S3	Sm
1N3892	S2a	R	2N2368	S3	Sm	2N4126	S3	Sm
1N3893	S2a	R	2N2369	S3	Sm	2N4391	S5	FET
1N3909	S2a	R	2N2369A	S3	Sm	2N4392	S5	FET
1N3910	S2a	R	2N2483	S3	Sm	2N4393	S5	FET
1N3911	S2a	R	2N2484	S3	Sm	2N4427	S6	RFP
1N3912	S2a	R	2N2904	S3	Sm	2N4856	S5	FET
1N3913	S2a	R	2N2904A	S3	Sm	2N4857	S5	FET
1N4001G	S1	R	2N2905	S3	Sm	2N4858	S5	FET

A = Accessories
 FET = Field-effect transistors
 Ph = Photoconductive devices
 PhC = Photocouplers
 R = Rectifier diodes

RFP = R.F. power transistors and modules
 SD = Small-signal diodes
 Sm = Small-signal transistors
 WBT = Wideband transistors

INDEX

type no.	book	section	type no.	book	section
2N4859	S5	FET	56359d	S2, 4b	A
2N4860	S5	FET	56360a	S2, 4b	A
2N4861	S5	FET	56363	S2, 4b	A
2N5400	S3	Sm	56364	S2, 4b	A
2N5401	S3	Sm	56367	S2a/b	A
2N5415	S3	Sm	56368b	S2, 4b	A
2N5416	S3	Sm	56368c	S2, 4b	A
2N5550	S3	Sm	56369	S2, 4b	A
2N5551	S3	Sm	56378	S2, 4b	A
2N6659	S5	FET	56379	S2, 4b	A
2N6660	S5	FET	56387a, b	S4b	A
2N6661	S5	FET	56397	S8b	A
4N25	S8b	PhC			
4N25A	S8b	PhC			
4N26	S8b	PhC			
4N27	S8b	PhC			
4N28	S8b	PhC			
4N35	S8b	PhC			
4N36	S8b	PhC			
4N37	S8b	PhC			
4N38	S8b	PhC			
4N38A	S8b	PhC			
502CQF	S8b	Ph			
503CQF	S8b	Ph			
504CQL	S8b	Ph			
516CQF-B	S8b	Ph			
56201d	S4b	A			
56201j	S4b	A			
56245	S3, 10	A			
56246	S3, 10	A			
56261a	S4b	A			
56264	S2a/b	A			
56295	S2a/b	A			
56326	S4b	A			
56339	S4b	A			
56352	S4b	A			
56353	S4b	A			
56354	S4b	A			
56359b	S2, 4b	A			
56359c	S2, 4b	A			

A = Accessories
 FET = Field-effect transistors
 Ph = Photoconductive devices
 PhC = Photocouplers
 Sm = Small-signal diodes

DATA HANDBOOK SYSTEM

DATA HANDBOOK SYSTEM

Our Data Handbook System comprises more than 60 books with specifications on electronic components, subassemblies and materials. It is made up of four series of handbooks:

ELECTRON TUBES	BLUE
SEMICONDUCTORS	RED
INTEGRATED CIRCUITS	PURPLE
COMPONENTS AND MATERIALS	GREEN

The contents of each series are listed on pages iv to vii.

The data handbooks contain all pertinent data available at the time of publication, and each is revised and reissued periodically.

When ratings or specifications differ from those published in the preceding edition they are indicated with arrows in the page margin. Where application information is given it is advisory and does not form part of the product specification.

Condensed data on the preferred products of Philips Electronic Components and Materials Division is given in our Preferred Type Range catalogue (issued annually).

Information on current Data Handbooks and on how to obtain a subscription for future issues is available from any of the Organizations listed on the back cover.

Product specialists are at your service and enquiries will be answered promptly.

ELECTRON TUBES (BLUE SERIES)

The blue series of data handbooks comprises:

- T1** **Tubes for r.f. heating**
- T2a** **Transmitting tubes for communications, glass types**
- T2b** **Transmitting tubes for communications, ceramic types**
- T3** **Klystrons**
- T4** **Magnetrons for microwave heating**
- T5** **Cathode-ray tubes**
Instrument tubes, monitor and display tubes, C.R. tubes for special applications
- T6** **Geiger-Müller tubes**
- T8** **Colour display systems**
Colour TV picture tubes, colour data graphic display tube assemblies, deflection units
- T9** **Photo and electron multipliers**
- T10** **Plumbicon camera tubes and accessories**
- T11** **Microwave semiconductors and components**
- T12** **Vidicon and Newvicon camera tubes**
- T13** **Image intensifiers and infrared detectors**
- T15** **Dry reed switches**
- T16** **Monochrome tubes and deflection units**
Black and white TV picture tubes, monochrome data graphic display tubes, deflection units

SEMICONDUCTORS (RED SERIES)

The red series of data handbooks comprises:

- S1 Diodes**
Small-signal silicon diodes, voltage regulator diodes ($< 1,5 \text{ W}$), voltage reference diodes, tuner diodes, rectifier diodes
- S2a Power diodes**
- S2b Thyristors and triacs**
- S3 Small-signal transistors**
- S4a Low-frequency power transistors and hybrid modules**
- S4b High-voltage and switching power transistors**
- S5 Field-effect transistors**
- S6 R.F. power transistors and modules**
- S7 Surface mounted semiconductors**
- S8a Light-emitting diodes**
- S8b Devices for optoelectronics**
Optocouplers, photosensitive diodes and transistors, infrared light-emitting diodes and infrared sensitive devices, laser and fibre-optic components
- S9 Power MOS transistors**
- S10 Wideband transistors and wideband hybrid IC modules**
- S11 Microwave transistors**
- S12 Surface acoustic wave devices**
- S13 Semiconductor sensors**
- S14 Liquid Crystal Displays**

INTEGRATED CIRCUITS (PURPLE SERIES)

The purple series of handbooks comprises:

IC01	Radic, audio and associated systems Bipolar, MOS	published 1986
IC02a/b	Video and associated systems Bipolar, MOS	published 1986
IC03	Integrated circuits for telephony Bipolar, MOS	published 1986
IC04	HE4000B logic family CMOS	published 1986
IC05N	HE4000B logic family – uncased ICs CMOS	published 1984
IC06N	High-speed CMOS, PC74HC/HCT/HCU Logic family	published 1986
IC08	ECL 10K and 100K logic families	published 1986
IC09N	TTL logic series	published 1986
IC10	Memories MOS, TTL, ECL	new issue 1987
IC11N	Linear LSI	published 1985
Supplement to IC11N	Linear LSI	published 1986
IC12	I²C-bus compatible ICs	not yet issued
IC13	Semi-custom Programmable Logic Devices (PLD)	new issue 1987
IC14	Microcontrollers and peripherals Bipolar, MOS	new issue 1987
IC15	FAST TTL logic series	published 1986
IC16	CMOS integrated circuits for clocks and watches	published 1986
IC17	Integrated Services Digital Networks (ISDN)	not yet issued
IC18	Microprocessors and peripherals	new issue 1987

COMPONENTS AND MATERIALS (GREEN SERIES)

The green series of data handbooks comprises:

- C2** Television tuners, coaxial aerial input assemblies
- C3** Loudspeakers
- C4** Ferroxcube potcores, square cores and cross cores
- C5** Ferroxcube for power, audio/video and accelerators
- C6** Synchronous motors and gearboxes
- C7** Variable capacitors
- C8** Variable mains transformers
- C9** Piezoelectric quartz devices
- C11** Varistors, thermistors and sensors
- C12** Potentiometers, encoders and switches
- C13** Fixed resistors
- C14** Electrolytic and solid capacitors
- C15** Ceramic capacitors
- C16** Permanent magnet materials
- C17** Stepping motors and associated electronics
- C18** Direct current motors
- C19** Piezoelectric ceramics
- C20** Wire-wound components for TVs and monitors
- C22** Film capacitors

Electronic components and materials for professional, industrial and consumer uses from the world-wide Philips Group of Companies

Argentina: PHILIPS ARGENTINA S.A., Div. Elcoma, Vedia 3892, 1430 BUENOS AIRES, Tel. (01) 541 - 7141 to 7747.
Australia: PHILIPS INDUSTRIALS LTD., Elcoma Division, 11 Waltham Street, ARTARMON, N.S.W. 2064, Tel. (02) 439 3322.
Austria: ÖSTERREICHISCHE PHILIPS INDUSTRIE G.m.b.H., UB Bauelemente, Triester Str. 64, A-1101 WIEN, Tel. (0222) 62 91 11-0.
Belgium: N.V. PHILIPS & MBLE ASSOCIATED, 80 Rue Des Deux Gares, B-1070 BRUXELLES, Tel. (02) 525-61-11.
Brazil: CONSTANTA-IBRAPE; (Active Devices): Av. Brigadeiro Faria Lima, 1735-SAO PAULO-SP, Tel. (011) 211-2600, (Passive Devices & Materials): Av. Francisco Monteiro, 702 - RIBEIRAO PIRES-SP, Tel. (011) 459-8211.
Canada: PHILIPS ELECTRONICS LTD., Elcoma Division, 601 Milner Ave., SCARBOROUGH, Ontario, M1B 1M8, Tel. (416) 292-5161.
Chile: PHILIPS CHILENA S.A., Av. Santa Maria 0760, SANTIAGO, Tel. (02) 77 38 16.
Colombia: IND. PHILIPS DE COLOMBIA S.A., c/o IPRELENTO LTD., Cra. 21, No. 56-17, BOGOTA, D.E., Tel. (01) 249 76 24.
Denmark: MINIWATT A/S, Strandlodsvej 2, P.O. Box 1919, DK 2300 COPENHAGEN S, Tel. (01) 54 11 33.
Finland: OY PHILIPS AB, Elcoma Division, Kaivokatu 8, SF-00100 HELSINKI 10, Tel. (90) 1 72 71.
France: RTC-COMPELEC, 130 Avenue Ledru Rollin, F-75540 PARIS 11, Tel. (01) 43 38 80 00.
Germany (Fed. Republic): VALVO, UB Bauelemente der Philips G.m.b.H., Valvo Haus, Burchardstrasse 19, D-2 HAMBURG 1, Tel. (040) 3296-0.
Greece: PHILIPS HELLENIQUE S.A., Elcoma Division, No. 15, 25th March Street, GR 17778 TAVROS, Tel. (01) 48 94 339/48 94 911.
Hong Kong: PHILIPS HONG KONG LTD., Elcoma Div., 15/F Philips Ind. Bldg., 24-28 Kung Yip St., KWAI CHUNG, Tel. (0)-24 51 21.
India: PEICO ELECTRONICS & ELECTRICALS LTD., Elcoma Dept., Band Box Building, 254-D Dr. Annie Besant Rd., BOMBAY - 400 025, Tel. (022) 4930311/4930590.
Indonesia: PT. PHILIPS-RALIN ELECTRONICS, Elcoma Div., Setiabudi II Building, 6th Fl., Jalan H.R. Rasuna Said (P.O. Box 223/KBY) Kuningan, JAKARTA 12910, Tel. (021) 51 79 95.
Ireland: PHILIPS ELECTRICAL (IRELAND) LTD., Elcoma Division, Newstead, Clonskeagh, DUBLIN 14, Tel. (01) 6933 55.
Italy: PHILIPS S.p.A., Div. Componenti Elcoma, Piazza IV Novembre 3, I-20124 MILANO, Tel. (02) 6752.1.
Japan: NIHON PHILIPS CORP., Shuwa Shinagawa Bldg., 26-33 Takanawa 3-chome, Minato-ku, TOKYO (108), Tel. (03) 448-5611. (IC Products) SIGNETICS JAPAN LTD., 8-7 Sanbancho Chiyoda-ku, TOKYO 102, Tel. (03) 230-1521.
Korea (Republic of): PHILIPS ELECTRONICS (KOREA) LTD., Elcoma Div., Philips House, 260-199 Itaewon-dong, Yongsan-ku, SEOUL, Tel. (02) 794-5011.
Malaysia: PHILIPS MALAYSIA SDN BHD, Elcoma Div., 345 Jalan Gelugor, 11700 PULAU PINANG, Tel. (04) 87 00 44.
Mexico: ELECTRONICA, S.A de C.V., Carr. México-Toluca km. 62.5, TOLUCA, Edo. de México 50140, Tel. Toluca 91 (721) 613-00.
Netherlands: PHILIPS NEDERLAND, Marktgroep Elcoma, Postbus 90050, 5600 PB EINDHOVEN, Tel. (040) 78 37 49.
New Zealand: PHILIPS NEW ZEALAND LTD., Elcoma Division, 110 Mt. Eden Road, C.P.O. Box 1041, AUCKLAND, Tel. (09) 605-914.
Norway: NORSK A/S PHILIPS, Electronica Dept., Sandstuveien 70, OSLO 6, Tel. (02) 68 02 00.
Pakistan: PHILIPS ELECTRICAL CO. OF PAKISTAN LTD., Philips Markaz, M.A. Jinnah Rd., KARACHI-3, Tel. (021) 72 57 72.
Peru: CADESA, Av. Alfonso Ugarte 1268, LIMA 5, Tel. (014) 326070.
Philippines: PHILIPS INDUSTRIAL DEV. INC., 2246 Pasong Tamo, P.O. Box 911, Makati Comm. Centre, MAKATI-RIZAL 3116, Tel. (02) 86 89 51 to 59.
Portugal: PHILIPS PORTUGUESA S.A.R.L., Av. Eng. Duarte Pacheco 6, 1009 LISBOA Codex, Tel. (019) 68 31 21.
Singapore: PHILIPS PROJECT DEV. (Singapore) PTE LTD., Elcoma Div., Lorong 1, Toa Payoh, SINGAPORE 1231, Tel. 35 02 000.
South Africa: S.A. PHILIPS (Pty) LTD., EDAC Div., 3rd Floor Rainer House, Upper Railway Rd. & Ove St., New Doornfontein, JOHANNESBURG 2001, Tel. (011) 402-4600/07.
Spain: MINIWATT S.A., Balmes 22, 08007 BARCELONA, Tel. (03) 301 63 12.
Sweden: PHILIPS KOMPONENTER A.B., Lidingövägen 50, S-11584 STOCKHOLM, Tel. (08) 7821000.
Switzerland: PHILIPS A.G., Elcoma Dept., Allmendstrasse 140-142, CH-8027 ZÜRICH, Tel. (01) 488 22 11.
Taiwan: PHILIPS TAIWAN LTD., 150 Tun Hua North Road, P.O. Box 22978, TAIPEI, Taiwan, Tel. (02) 7120500.
Thailand: PHILIPS ELECTRICAL CO. OF THAILAND LTD., 283 Silom Road, P.O. Box 961, BANGKOK, Tel. (02) 233-6330-9.
Turkey: TÜRK PHILIPS TICARET A.S., Elcoma Department, İnönü Cad., No. 78-80, 80090 Ayazpasa İSTANBUL, Tel. (01) 143 59 10.
United Kingdom: MULLARD LTD., Mullard House, Torrington Place, LONDON WC1E 7HD, Tel. (01) 580 6633.
United States: (Active Devices & Materials) AMPEREX SALES CORP., Providence Pike, SLATERSVILLE, R.I. 02876, Tel. (401) 762-9000. (Passive & Electromech. Dev.) MEPCO/CENTRALAB, INC., 2001 West Blue Heron Blvd, RIVIERA BEACH, Florida 33404, Tel. (305) 881-3200. (IC Products) SIGNETICS CORPORATION, 811 East Arques Avenue, SUNNYVALE, CA 94088-3409, Tel. (408) 991-2000. (Colour picture tubes - Monochrome & Colour display tubes) PHILIPS ECG INC., 50 Johnston St., SENECA FALLS, N.Y. 13148, Tel. (315) 568-5881.
Uruguay: LUZILETRON S.A., Avda Uruguay 1287, P.O. Box 907, MONTEVIDEO, Tel. (02) 98 53 95.
Venezuela: IND. VENEZOLANAS PHILIPS S.A., c/o MAGNETICA S.A., Calle 6, Ed. Las Tres Jotas, App. Post. 78117, CARACAS, Tel. (02) 239 39 31.
For all other countries apply to: Philips Electronic Components and Materials Division, International Business Relations, P.O. Box 218, 5600 MD EINDHOVEN, The Netherlands, Telex 35000 phtnl

A55

© Philips Export B.V. 1987

This information is furnished for guidance, and with no guarantee as to its accuracy or completeness; its publication conveys no licence under any patent or other right, nor does the publisher assume liability for any consequence of its use; specifications and availability of goods mentioned in it are subject to change without notice; it is not to be reproduced in any way, in whole or in part, without the written consent of the publisher.